

**RFB NO. 314002**

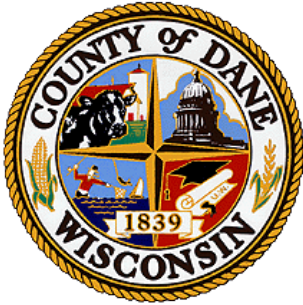

## **CONSTRUCTION DOCUMENTS PROJECT MANUAL**

DANE COUNTY DEPARTMENT OF PUBLIC WORKS,  
HIGHWAY AND TRANSPORTATION

SOLID WASTE DIVISION  
1919 ALLIANT ENERGY CENTER WAY  
MADISON, WISCONSIN 53713

### **REQUEST FOR BIDS NO. 314002 CLAY EXCAVATION AND TRUCKING DANE COUNTY LANDFILL SITE #2 7102 U.S. HIGHWAY 12 & 18 MADISON, WISCONSIN**

Due Date / Time: **TUESDAY, FEBRUARY 18, 2014 / 2:00 P.M.**

Location: **PUBLIC WORKS OFFICE**

Performance / Payment Bond: **100% OF CONTRACT AMOUNT**

Bid Deposit: **5% OF BID AMOUNT**

---

FOR INFORMATION ON THIS REQUEST FOR BIDS, PLEASE CONTACT:

JOHN WELCH, PROJECT MANAGER  
TELEPHONE NO.: 608/516-4154  
FAX NO.: 608/267-1533  
E-MAIL: [WELCH@COUNTYOFDANE.COM](mailto:WELCH@COUNTYOFDANE.COM)

## **DOCUMENT INDEX FOR RFB NO. 314002**

### **PROCUREMENT AND CONTRACTING REQUIREMENTS**

- Project Manual Cover Page
- Documents Index
- Invitation to Bid (Legal Notice)
- Instructions to Bidders
- Bid Form
- Fair Labor Practices Certification
- Best Value Contracting Application
- Sample Public Works Contract
- Sample Bid Bond
- Sample Performance Bond
- Sample Payment Bond
- General Conditions of Contract
- Supplementary Conditions

### **GENERAL REQUIREMENTS**

- 01 00 00 - Basic Requirements
- 02 55 00 – Erosion Control

### **DESCRIPTION OF WORK**

- Definitions
- Scope of Work

### **APPENDICES**

- Appendix A      Plan for work at Excavation Site
- Appendix B      Plan showing location of Rodefeld Stockpile on the Rodefeld Landfill Site

## **LEGAL NOTICE**

### **INVITATION TO BID**

Dane County Public Works, Highway & Transportation Dept., 1919 Alliant Energy Center Way, Madison, WI 53713, will receive sealed Bids until:

**2:00 P.M., TUESDAY, FEBRUARY 18, 2014**

**REQUEST FOR BIDS NO. 314002**  
**CLAY EXCAVATION AND TRUCKING**  
**DANE COUNTY LANDFILL SITE #2**  
**7102 U.S. HIGHWAY 12 & 18**  
**MADISON, WISCONSIN**

Dane County is inviting Bids for excavation and trucking services. Work will be composed of one of three options. The first option is for hauling clay from the Westport Clay Borrow Location to the Rodefild Landfill Site. The second option includes all Work outlined in Option 1 and all Civil site Work, including clay excavation, erosion control, and site restoration. The third option is for the Contractor to supply clay from another source and deliver it to the Rodefild Landfill site.

Request for Bids package may be obtained after 2:00 P.M., Thursday, January 23, 2014 at Dane County Public Works, Highway & Transportation Dept., 1919 Alliant Energy Center Way, Madison, WI 53713, by calling 608/266-4018, or downloading it from [www.countyofdane.com/pwht/bid/logon.aspx](http://www.countyofdane.com/pwht/bid/logon.aspx). Please call John Welch, Project Manager, at 608/516-4154 for any questions or additional information.

All Bidders must be a registered vendor with Dane County & pay an annual registration fee & must be pre-qualified as a Best Value Contractor before award of Contract. Complete Vendor Registration Form at [www.danepurchasing.com/registration](http://www.danepurchasing.com/registration) or obtain one by calling 608/266-4131. Complete Pre-qualification Application for Contractors at [www.countyofdane.com/pwht/BVC\\_Application.aspx](http://www.countyofdane.com/pwht/BVC_Application.aspx) or obtain one by calling 608/266-4018.

### **PUBLISH:**

**JANUARY 23 AND JANUARY 30, 2014 - WISCONSIN STATE JOURNAL**  
**JANUARY 23 AND JANUARY 30, 2014 - THE DAILY REPORTER**

# INSTRUCTIONS TO BIDDERS

## TABLE OF CONTENTS

1. GENERAL.....	1
2. DRAWINGS AND SPECIFICATIONS .....	1
3. INTERPRETATION .....	2
4. QUALIFICATIONS OF BIDDER (CONTRACTOR AND SUBCONTRACTOR)....	2
5. BID GUARANTEE .....	3
6. WITHDRAWAL OF BIDS.....	3
7. CONTRACT FORM.....	3
8. CONTRACT INTERESTS BY COUNTY PUBLIC OFFICIALS .....	3
9. EMERGING SMALL BUSINESS PROVISIONS .....	4
10. METHOD OF AWARD - RESERVATIONS .....	5
11. SECURITY FOR PERFORMANCE AND PAYMENTS .....	6
12. TAXES.....	6
13. SUBMISSION OF BIDS .....	6
14. SUBCONTRACTOR LISTING.....	7
15. ALTERNATE BIDS .....	7
16. INFORMATIONAL BIDS .....	8
17. UNIT PRICES.....	8
18. COMMENCEMENT AND COMPLETION .....	8
19. WORK BY OWNER .....	8
20. SPECIAL HAZARDS COVERAGE.....	8
FORM A .....	9
FORM B.....	10
FORM C.....	11
FORM D .....	12

### **1. GENERAL**

- A. Before submitting Bid, bidder shall thoroughly examine all Construction Documents. Successful Bidder shall be required to provide all the Work that is shown on Drawings, set forth in Specifications, or reasonably implied as necessary to complete Contract for this project.
- B. Bidder shall visit site to become acquainted with adjacent areas, means of approach to site, conditions of actual site and facilities for delivering, storing, placing, and handling of materials and equipment.
- C. Site visits can be arranged. Coordinate site access activities with Project Manager, John Welch, 608/266-4018.
- D. Failure to visit site or failure to examine any and all Construction Documents will in no way relieve successful Bidder from necessity of furnishing any necessary materials or equipment, or performing any work, that may be required to complete the Work in accordance with Drawings and Specifications. Neglect of above requirements will not be accepted as reason for delay in the Work or additional compensation.

### **2. DRAWINGS AND SPECIFICATIONS**

- A. Drawings and Specifications that form part of this Contract, as stated in Article 1 of General Conditions of Contract are enumerated in Document Index of these Construction Documents.

- B. Complete sets of Drawings and Specifications for all trades will be issued to all Bidders, irrespective of category of work to be bid on, in order that all Bidders may be familiar with work of other trades as they affect their bid.

### **3. INTERPRETATION**

- A. No verbal explanation or instructions will be given in regard to meaning of Drawings or Specifications before Bid Due Date. Bidders shall bring inadequacies, omissions or conflicts to Owner or Architect / Engineer's attention at least ten (10) days before Bid Due Date. Prompt clarification will be available to all bidders by Addendum.
- B. Failure to so request clarification or interpretation of Drawings and Specifications will not relieve successful Bidder of responsibility. Signing of Contract will be considered as implicitly denoting that Contractor has thorough understanding of scope of the Work and comprehension of Construction Documents.
- C. Owner will not be responsible for verbal instructions.

### **4. QUALIFICATIONS OF BIDDER (CONTRACTOR AND SUBCONTRACTOR)**

- A. Before award of Contract can be approved, Owner shall be satisfied that Bidder involved meets following requirements:
  - 1. Has completed at least one (1) project of at least fifty percent (50%) of size or value of Division of work being bid and type of work completed is similar to that being bid. If greater magnitude of experience is deemed necessary, other than size or value of work, such requirements will be described in appropriate section of Specifications.
  - 2. Maintains permanent place of business.
  - 3. Can be bonded for terms of proposed Contract.
  - 4. Has record of satisfactorily completing past projects. Criteria which will be considered in determining satisfactory completion of projects by bidder will include:
    - a. Completed contracts in accordance with drawings and specifications.
    - b. Diligently pursued execution of work and completed contracts according to established time schedule unless Owner grants extensions.
    - c. Fulfilled guarantee requirements of construction documents.
    - d. Is not presently on ineligible list maintained by County's Department of Administration for noncompliance with equal employment opportunities and affirmative action requirements.
    - e. Authorized to conduct business in Wisconsin. By submitting Bid, bidder warrants that it has: complied with all necessary requirements to do business in State of Wisconsin; that persons executing contract on its behalf are authorized to do so; and, if corporation, that name and address of bidder's registered agent are as set forth in Contract. Bidder shall notify Owner immediately, in writing, of any change in its registered agent, their address, and bidder's legal status. For partnership, term "registered agent" shall mean general partner.
- B. County's Public Works Project Engineer will make such investigations as are deemed necessary to determine ability of bidder to perform the Work, and bidder shall furnish to County's Public Works Project Engineer or designee all such information and data for this

purpose as County's Public Works Project Engineer may request. Owner reserves right to reject Bid if evidence submitted by, or investigation of, bidder fails to satisfy Owner that bidder is responsible and qualified to carry out obligations of Contract and to complete the Work contemplated therein.

## **5. BID GUARANTEE**

- A. Bank certified check, cashier's check or Bid Bond, payable to County in amount not less than five percent (5%) of maximum bid, shall accompany each Bid as guarantee that if Bid is accepted, Bidder will execute and return proposed Contract and Performance and Payment Bonds within ten (10) days after being notified of acceptance of Bid. Company issuing bonds must be licensed to do business in Wisconsin.
- B. Any bid, which is not accompanied by bid guarantee, will be considered "No Bid" and will not be read at Bid Due Date.
- C. If successful Bidder so delivers Contract, Certificate of Insurance, and Performance and Payment Bonds, check will be returned to Bidder. In case Bidder fails to deliver such Contract, insurance, and bond, amount of bid guarantee will be forfeited to County as liquidated damages.
- D. All checks tendered as bid guarantee, except those of three (3) lowest qualified, responsible bidders, will be returned to their makers within three (3) days after Bid Due Date. All such retained checks will be returned immediately upon signing of Contract and Performance and Payment Bonds by successful Bidder.

## **6. WITHDRAWAL OF BIDS**

- A. Bids may be withdrawn by written request received from bidder or authorized representative thereof prior to time fixed for Bid Due Date, without prejudice to right of bidder to file new Bid. Withdrawn Bids will be returned unopened. Negligence on part of bidder in preparing their Bid confers no right for withdrawal of Bid after it has been opened.
- B. No Bid may be withdrawn for period of sixty (60) days after Bid Due Date.
- C. If Bid contains error, omission or mistake, bidder may limit liability to amount of bidder's guarantee by giving written Notice of Intent not to execute Contract to Owner within seventy-two (72) hours of Bid Due Date.

## **7. CONTRACT FORM**

- A. Sample copy of contract that successful Bidder will be required to enter into is included in these Construction Documents and bidders are required to familiarize themselves with all conditions contained therein.

## **8. CONTRACT INTERESTS BY COUNTY PUBLIC OFFICIALS**

- A. In accordance with Wisconsin Statute 946.13, county official may not bid for or enter into any contract involving receipts or disbursements of more than \$15,000.00 in a year, in which they have private pecuniary interest, direct or indirect if at same time they are authorized to take official action with respect to making of this Contract. Any contract entered into in violation of this Statute is void and County incurs no liability thereon. This subsection does not affect application and enforcement of Wisconsin Statute 946.13 by state prosecutors in criminal courts of this state.

## 9. EMERGING SMALL BUSINESS PROVISIONS

- A. **Emerging Small Business Definition.** For purposes of this provision, ESB is defined as:
1. Independent business concern that has been in business minimum of one year;
  2. Business located in State of Wisconsin;
  3. Business comprised of less than twenty-five (25) employees;
  4. Business must not have gross sales in excess of three million dollars (\$3,000,000.00) over past three years; and
  5. Business does not have history of failing to complete projects.
- B. **Emerging Small Business (ESB) Involvement.** Bidder shall make good faith effort to award minimum of ten percent (10%) of the Work to ESBs. Bidder shall submit report to Dane County Contract Compliance Officer within twenty-four (24) hours after Bid Due Date demonstrating such efforts. Good faith efforts means significant contact with ESBs for purposes of soliciting bids from them. Failure to make or demonstrate good faith efforts will be grounds for disqualification.
- C. **Emerging Small Business Report.** Emerging Small Business Enterprise Report is to be submitted by Bidder in separate envelope marked "Emerging Small Business Report". This report is due by 2:00 p.m. following specified twenty-four (24) hours after Bid Due Date. Bidder who fails to submit Emerging Small Business Report shall be deemed not responsive.
- D. **ESB Goal.** Goal of this project is ten percent (10%) ESB participation. ESB utilizations are shown as percentage of total Bid. If Bidder meets or exceeds specified goal, Bidder is only required to submit Form A - Certification, and Form B - Involvement. Goal shall be met if Bidder qualifies as ESB.
- E. **Report Contents.** Following award of Contract, Bidder shall submit copies of executed contracts for all Emerging Small Businesses. Emerging Small Business Report shall consist of these:
1. Form A - Certification;
  2. Form B - Involvement;
  3. Form C - Contacts;
  4. Form D - Certification Statement (if appropriate); and
  5. Supportive documentation (i.e., copies of correspondence, telephone logs, copies of advertisements).
- F. **ESB Listing.** Bidders will solicit bids from ESB listing provided by Dane County.
- G. **ESB Certification.** All contractors, subcontractors and suppliers seeking ESB certification must complete and submit Emerging Small Business Certification Application to Dane County Contract Compliance Program.
- H. **Certification Statement.** If ESB firm has not been certified by County as ESB prior to submittal of this Bid, ESB Report cannot be used to fulfill ESB goal for this project unless

firm provides "Form D - Certification Statement". Certification statement must be completed and signed by ESB firm.

I. **Questions.** Questions concerning Emerging Small Business provisions shall be directed to:

Dane County Contract Compliance Officer  
City-County Building, Room 421  
210 Martin Luther King, Jr. Blvd.  
Madison, WI 53703  
608/266-5623

J. **Substituting ESBs.** In event of any significant changes in subcontract arrangements or if need arises to substitute ESBs, Bidder shall report such proposed changes to Contract Compliance Officer to making any official changes and request authorization to substitute ESB firm. Bidder further agrees to make every possible effort to replace ESB firm with another qualified ESB firm.

K. **Good Faith Efforts.** Good faith efforts can be demonstrated by meeting all of these obligations:

1. Selecting portions of the Work to be performed by ESBs in order to increase likelihood of meeting ESB goal including, where appropriate, breaking down Contract into smaller units to facilitate ESB participation.
2. Advertising in general circulation, trade associations and women / minority focus media concerning subcontracting opportunities.
3. Providing written notices to reasonable number of specific ESBs that their interest in Contract was being solicited in sufficient time to allow ESBs to participate effectively.
4. Following up on initial solicitations of interest by contacting ESBs within five (5) working days prior to Bid Due Date to determine with certainty whether ESB were interested, to allow ESBs to prepare bids.
5. Providing interested ESB with adequate information about Drawings, Specifications and requirements of Contract.
6. Using services of available minority, women and small business organizations and other organizations that provide assistance in recruitment of MBEs / WBEs / ESBs.
7. Negotiating in good faith with interested ESBs, not rejecting ESBs as unqualified without sound reason based on thorough investigation of their capabilities.
8. Submitting required project reports and accompanying documents to County's Contract Compliance Officer within twenty-four (24) hours after Bid Due Date.

L. **Appeals Disqualification of Bid.** Bidder who is disqualified may appeal to Public Works & Transportation Committee and Equal Opportunity Commission.

**10. METHOD OF AWARD - RESERVATIONS**

A. Following will be basis of award of Contract, providing cost does not exceed amount of funds then estimated by County as available to finance Contract(s):



1. Lowest dollar amount submitted by qualified responsible bidder on Base Bid for all work comprising project, combined with such additive Owner accepted alternates.
2. Owner reserves right to reject all bids or any bid, to waive any informality in any bid, and to accept any bid that will best serve interests of County.
3. Unit Prices and Informational Bids will not be considered in establishing low bidder.

## **11. SECURITY FOR PERFORMANCE AND PAYMENTS**

- A. Simultaneous with delivery of signed Contract, Bidder shall be required to furnish Performance and Payment Bonds as specified in Article 29 of General Conditions of Contract, "Contract Security." Surety Company shall be licensed to do business in Wisconsin. Performance and Payment Bonds must be dated same date or subsequent to date of Contract. Performance and Payment Bonds must emulate information in Sample Performance and Payment Bonds in Construction Documents.
- B. Provide certified copy of power of attorney from Surety Company showing that agent who signs Bond has power of attorney to sign for Surety Company. Secretary or Assistant Secretary of company must sign this certification, not attorney-in-fact. Certification must bear same or later date as Bond. Power of Attorney must emulate model power of attorney information detailed in Sample Performance and Payment Bonds.
- C. If Bidder is partnership or joint venture, State certified list, providing names of individuals constituting partnership or joint venture must be furnished. Contract itself may be signed by one partner of partnership, or one partner of each firm comprising joint venture, but Performance and Payment Bonds must be signed by all partners.
- D. If Bidder is a corporation, it is necessary that current certified copy of resolution or other official act of directors of corporation be submitted showing that person who signs Contract is authorized to sign contracts for corporation. It is also necessary that corporate seal be affixed to resolution, contract, and performance and payment bonds. If your corporation has no seal, it is required that above documents include statement or notation to effect that corporation has no seal.

## **12. TAXES**

- A. Bidder shall include in Bid, all Sales, Consumer, Use and other similar taxes required by law.
- B. In accordance with Wisconsin Statute 71.80(16)(a), successful nonresident bidder, whether incorporated or not, and not otherwise regularly engaged in business in this state, shall file surety bond with State of Wisconsin Department of Revenue payable to Department of Revenue, to guarantee payment of income taxes, required unemployment compensation contributions, sales and use taxes and income taxes withheld from wages of employees, together with any penalties and interest thereon. Amount of bond shall be three percent (3%) of Contract or subcontract price on all contracts of \$50,000 or more.

## **13. SUBMISSION OF BIDS**

- A. All Bids shall be submitted on standard Bid Form bound herein and only Bids that are made on this Bid Form will be considered. Entire Bid Form and other supporting documents, if any, shall be removed or copied from Construction Documents, filled out, and submitted in manner specified hereinafter. Submit completed Bid Bond with Bid as well.

- B. No bids for any subdivision or any sub-classification of this Work, except as indicated, will be accepted. Any conditional Bid, amendment to Bid Form or appended item thereto, or inclusion of any correspondence, written or printed matter, or details of any nature other than that specifically called for, which would alter any essential provision of Construction Documents, or require consideration of unsolicited material or data in determining award of Contract, will disqualify Bid. Telecommunication alterations to Bid will not be accepted.
- C. Bidders must submit single Bid for all the Work.
- D. Bid amounts shall be inserted in words and in figures in spaces provided on Bid Form; in case of conflict, written word amounts will govern.
- E. Addenda issued after Bid Letting shall become part of Construction Documents. Bidders shall acknowledge receipt of such addenda in appropriate space provided on Bid Form. Bid may be rejected if receipt of any particular addendum applicable to award of Contract has not been acknowledged on Bid Form.
- F. Bids shall be signed, placed in envelope, sealed and delivered before due time to place designated in Invitation to Bid, and identified with project name, bid number, location, category of work being bid upon, Bid Due Date, name and address of bidder.
- G. Bidder shall be responsible for sealed Bid being delivered to place designated for Bid Due Date on or before date and time specified. Bids received after time of closing will be rejected and returned to bidder unopened.
- H. Bid will be considered invalid and will be rejected if bidder has not signed it.
- I. Faxed Bids will not be accepted.
- J. Bidder's organization shall submit completed with Bid, Fair Labor Practices Certification form, included in these Construction Documents.

#### **14. SUBCONTRACTOR LISTING**

- A. Bidders shall be required to submit list of major subcontractors for General Construction, Plumbing, HVAC, and Electrical work proposed for this project to include committed prices for each subcontractor. List shall be placed in separate sealed envelope that must be clearly identified as "Major Subcontractor List", for named project and name of Bidder submitting it. County must receive envelope no later than date by which successful Bidder is required to submit his or her signed Contract, as established in Construction Documents.

#### **15. ALTERNATE BIDS**

- A. Bidder shall carefully read requests for Alternate Bids, and thoroughly examine Drawings and Specifications to determine extent various changes and conditions will affect Bid.
- B. Space is provided in Bid Form for requested Alternate Bids. Failure to submit bid for any requested Alternate Bids may result in rejection of entire Bid.
- C. Bidder shall state amount to be added / subtracted to Base Bid for providing alternates, including all incidentals, omissions, additions, and adjustments as may be necessary or required by such changes. If there is no difference in price, Bidder shall state, "No Change".
- D. Descriptions of requested Alternate Bids are as set forth in Construction Documents.

## **16. INFORMATIONAL BIDS**

- A. Bidder shall state amount that is included in Base Bid for all equipment, materials and labor required to complete the Work described. Informational bids are amounts requested for accounting purposes and for allocation of funds only. It is not intended to omit any of the Work described or related items from this project.
- B. Description of requested Informational Bids, if any, is as set forth in Construction Documents.

## **17. UNIT PRICES**

- A. Provide unit prices where requested on Bid Form. Unit prices will include all costs for materials, labor, insurance, taxes, overhead and profit necessary to perform specified work. Estimated quantities are approximate only. Payment will be based upon actual quantities placed, provided or installed. Failure to provide requested unit prices may result in rejection of entire Bid.
- B. Owner reserves right to accept or reject any unit prices as given in Bid.
- C. Bidder shall refer to Bid Form and applicable specification section to determine basis of unit measure and detailed information related to each unit price item requested.

## **18. COMMENCEMENT AND COMPLETION**

- A. Successful Bidder shall commence work when schedule and weather permit, but no later than stated in Bid Form. Contractor shall pursue the Work regularly and continuously at reasonable rate to insure completion of the Work within time stated in Bid.
- B. Should it be found impossible to complete the Work on or before time specified for completion, written request may be submitted for extension of time setting forth reasons believed to justify granting of such request. Refer to Article 20 of General Conditions of Contract, titled "Time for Completion."

## **19. WORK BY OWNER**

- A. Work by Owner: Owner shall complete all work which Owner is responsible for as described in Scope of Work for whichever option is contracted for.

## **20. SPECIAL HAZARDS COVERAGE**

- A. Not Applicable.

**FORM A**

**DANE COUNTY  
EMERGING SMALL BUSINESS REPORT - CERTIFICATION**

In accordance with General Conditions of Contract, submit this Emerging Small Business Report within 24 hours after Bid Due Date.

PROJECT NAME: \_\_\_\_\_

\_\_\_\_\_

BID NO.: \_\_\_\_\_ BID DUE DATE: \_\_\_\_\_

**BIDDER INFORMATION**

COMPANY NAME: \_\_\_\_\_

ADDRESS: \_\_\_\_\_

\_\_\_\_\_

TELEPHONE NO.: \_\_\_\_\_

CONTACT PERSON: \_\_\_\_\_

**FORM B**

**DANE COUNTY  
EMERGING SMALL BUSINESS REPORT - INVOLVEMENT**

Page \_\_\_ of \_\_\_  
(Copy this Form as necessary to provide complete information)

COMPANY NAME: \_\_\_\_\_

PROJECT NAME: \_\_\_\_\_ BID NO.: \_\_\_\_\_

ESB NAME: \_\_\_\_\_ CONTACT PERSON: \_\_\_\_\_

ADDRESS: \_\_\_\_\_ PHONE NO.: \_\_\_\_\_

CITY: \_\_\_\_\_ STATE: \_\_\_\_\_ ZIP: \_\_\_\_\_

**Indicate percentage of financial commitment to this ESB: \_\_\_\_\_ % Amount: \$ \_\_\_\_\_**

ESB NAME: \_\_\_\_\_ CONTACT PERSON: \_\_\_\_\_

ADDRESS: \_\_\_\_\_ PHONE NO.: \_\_\_\_\_

CITY: \_\_\_\_\_ STATE: \_\_\_\_\_ ZIP: \_\_\_\_\_

**Indicate percentage of financial commitment to this ESB: \_\_\_\_\_ % Amount: \$ \_\_\_\_\_**

ESB NAME: \_\_\_\_\_ CONTACT PERSON: \_\_\_\_\_

ADDRESS: \_\_\_\_\_ PHONE NO.: \_\_\_\_\_

CITY: \_\_\_\_\_ STATE: \_\_\_\_\_ ZIP: \_\_\_\_\_

**Indicate percentage of financial commitment to this ESB: \_\_\_\_\_ % Amount: \$ \_\_\_\_\_**

**FORM C**

**DANE COUNTY  
EMERGING SMALL BUSINESS REPORT - CONTACTS**

Page \_\_\_ of \_\_\_

(Copy this Form as necessary to provide complete information)

COMPANY NAME: \_\_\_\_\_

PROJECT NAME: \_\_\_\_\_ BID NO.: \_\_\_\_\_

	<u>ESB FIRM NAME CONTACTED</u>	<u>DATE</u>	<u>PERSON CONTACTED</u>	<u>DID ESB BID?</u>	<u>DID YOU ACCEPT BID?</u>	<u>REASON FOR REJECTION</u>
1)	_____	_____	_____	_____	_____	_____
2)	_____	_____	_____	_____	_____	_____
3)	_____	_____	_____	_____	_____	_____
4)	_____	_____	_____	_____	_____	_____
5)	_____	_____	_____	_____	_____	_____
6)	_____	_____	_____	_____	_____	_____
7)	_____	_____	_____	_____	_____	_____

**FORM D**

**DANE COUNTY  
EMERGING SMALL BUSINESS REPORT - CERTIFICATION STATEMENT**

I, \_\_\_\_\_, \_\_\_\_\_ of  
Name Title

\_\_\_\_\_ certify to best of my knowledge and  
Company

belief that this business meets Emerging Small Business definition as indicated in Article 9 and  
that information contained in this Emerging Small Business Report is true and correct.

\_\_\_\_\_  
Bidder's Signature

\_\_\_\_\_  
Date

Name of Bidding Firm: \_\_\_\_\_

**BID FORM**

**BID NO. 314002**  
**PROJECT: CLAY TRUCKING AND EXCAVATION**  
**DANE COUNTY LANDFILL SITE #2**

**TO: DANE COUNTY DEPARTMENT OF PUBLIC WORKS, HIGHWAY & TRANSPORTATION PROJECT ENGINEER**  
**1919 ALLIANT ENERGY CENTER WAY**  
**MADISON, WISCONSIN 53713**

**BASE BID - UNIT PRICING**

The three bidding Options are described in the Scope of Work section. The undersigned, having examined the site where the Work is to be executed and having become familiar with local conditions affecting the cost of the Work and having carefully examined the Drawings and Specifications, all other Construction Documents and Addenda thereto prepared by Dane County Department of Public Works, Highway & Transportation hereby agrees to provide all labor, materials, equipment and services necessary for the complete and satisfactory execution of the entire Work, as specified in the Construction Documents, for the Base Bid unit pricing as follows:

**Option A:**

Dane county will perform all excavation, erosion control, and civil site work. Contractor Work:

**Base Bid A:**

78,000 tons hauled from excavation site to the stockpile at Rodefild Landfill Site between April 1 and July 7, 2014 with a minimum of 39,000 tons by June 16, 2014:

@ \$ \_\_\_\_\_/ton = \_\_\_\_\_

**Option A Alternate (optional):**

Additional hauling to Rodefild Landfill Site beyond the 78,000 tons included in Base Bid A, up to 102,000 additional tons to be completed by September 30, 2014:

\$ \_\_\_\_\_/ton



**Option B:**

Contractor will provide excavation, erosion control, and civil site work for extraction of clay from excavation site and will deposit material to the Rodefled Stockpile.

**Base Bid B:**

78,000 tons excavated and hauled from excavation site to the Rodefled Stockpile between April 1 and July 7, 2014 with a minimum of 39,000 tons by June 16, 2014:

- 1. Erosion control per drawings included in Appendix A \$ \_\_\_\_\_
- 2. Excavation of 78,000 tons of clay from site: @ \$ \_\_\_\_\_/ton = \_\_\_\_\_
- 3. Hauling of 78,000 tons of clay from excavation site to stockpile at Rodefled Landfill  
@ \$ \_\_\_\_\_/ton = \_\_\_\_\_
- 4. Restoration of impacted parts of site per grading plan included in Appendix A by August 15, 2014:  
\$ \_\_\_\_\_

Total Base Bid B (sum of lines 1 through 4): \$ \_\_\_\_\_

**Option B Alternate (optional):**

Additional Work beyond the 78,000 tons included in Base Bid B, up to 102,000 additional tons excavated and hauled from excavation site to the Rodefled Stockpile between July 7 and September 30, 2014:

- 5. Additional erosion control per drawings included in Appendix A \$ \_\_\_\_\_
- 6. Excavation of up to 102,000 additional tons of clay from site:  
@ \$ \_\_\_\_\_/ton = \_\_\_\_\_
- 7. Hauling of up to 102,000 additional tons of clay from excavation site to stockpile at Rodefled Landfill  
@ \$ \_\_\_\_\_/ton = \_\_\_\_\_
- 8. Additional restoration of impacted parts of site per grading plan included in Appendix A by October 15, 2014:  
\$ \_\_\_\_\_

Total Option B Alternate Bid (sum of lines 5 through 8): \$ \_\_\_\_\_

**Option C:**

Contractor to provide clay from another source. At least 78,000 tons must be delivered to the Rodefled Stockpile by July 7, 2014 with a minimum of 39,000 tons by June 16, 2014. Any additional clay supplied must be delivered by September 30, 2014.

Unit price supplied and delivered to Stockpile A at the Rodefled Landfill Site:

\$ \_\_\_\_\_/ton

Quantity available (at least 78,000 tons): \_\_\_\_\_ tons

Pit Name: \_\_\_\_\_

Location: \_\_\_\_\_

Indicate whether the clay source has been approved by the WDNR for use as a landfill liner. If it has, include a copy of approval documentation:

\_\_\_\_\_  
\_\_\_\_\_

I hereby certify that all statements herein are made on behalf of:

\_\_\_\_\_  
(Name of Corporation, Partnership or Person submitting Bid)

Select one of the following:

1. A corporation organized and existing under the laws of the State of \_\_\_\_\_, or
2. A partnership consisting of \_\_\_\_\_, or
3. A person conducting business as \_\_\_\_\_;

Of the City, Village, or Town of \_\_\_\_\_ of the State of \_\_\_\_\_.

I have examined and carefully prepared this Bid from the associated Construction Documents and have checked the same in detail before submitting this Bid; that I have full authority to make such statements and submit this Bid in (its) (their) (my) behalf; and that the said statements are true and correct. In signing this Bid, we also certify that we have not, either directly or indirectly, entered into any agreement or participated in any collusion or otherwise taken any action in restraint of free competition; that no attempt has been made to induce any other person or firm to submit or not to submit a Bid; that this Bid has been independently arrived at without collusion with any other bidder, competitor, or potential competitor; that this Bid has not been knowingly disclosed prior to the Bids Due Date to another bidder or competitor; that the above statement is accurate under penalty of perjury.

The undersigned further agrees to honor the Base Bid and the Alternate Bid(s) for 60 days from date of Award of Contract.

**SIGNATURE:** \_\_\_\_\_  
(Bid is invalid without signature)

Print Name: \_\_\_\_\_ Date: \_\_\_\_\_

Title: \_\_\_\_\_

Address: \_\_\_\_\_

Telephone No.: \_\_\_\_\_ Fax No.: \_\_\_\_\_

Email Address: \_\_\_\_\_

Contact Person: \_\_\_\_\_

Receipt of the following addenda and inclusion of their provisions in this Bid is hereby acknowledged:

Addendum No(s). \_\_\_\_\_ through \_\_\_\_\_

Dated \_\_\_\_\_

**THIS PAGE IS FOR BIDDERS' REFERENCE AND NEED NOT BE SUBMITTED WITH BID FORM.**

**BID CHECK LIST:**

These items **must** be included with Bid:

Bid Form

Bid Bond

Fair Labor Practices Certification

**BIDDERS SHOULD BE AWARE OF THE FOLLOWING:**

**DANE COUNTY VENDOR REGISTRATION PROGRAM**

Any person bidding on any County contract must be registered with the Dane County Purchasing Division & pay an annual registration fee. A contract will not be awarded to an unregistered vendor. Obtain a *Vendor Registration Form* by calling 608/266-4131 or complete a new form or renewal online at:

[www.danepurchasing.com/registration](http://www.danepurchasing.com/registration)

**DANE COUNTY BEST VALUE CONTRACTING PRE-QUALIFICATION**

Contractors must be pre-qualified as a Best Value Contractor with the Dane County Public Works Engineering Division before the award of contract. Obtain a *Best Value Contracting Application* by calling 608/266-4018 or complete one online at:

[www.countyofdane.com/pwht/BVC\\_Application.aspx](http://www.countyofdane.com/pwht/BVC_Application.aspx)

**EQUAL BENEFITS REQUIREMENT**

By submitting a Bid, the contractor acknowledges that a condition of this contract is to provide equal benefits as required by Dane County Code of Ordinances Chapter 25.016. Contractor shall provide equal benefits as required by that Ordinance to all required employees during the term of the contract. For more information:

[www.danepurchasing.com/partner\\_benefit.aspx](http://www.danepurchasing.com/partner_benefit.aspx)

## FAIR LABOR PRACTICES CERTIFICATION

Dane County Ordinance 25.11(28)

The undersigned, for and on behalf of the PROPOSER, BIDDER OR APPLICANT named herein, certifies as follows:

1. That he or she is an officer or duly authorized agent of the above-referenced PROPOSER, BIDDER OR APPLICANT, which has submitted a proposal, bid or application for a contract with the county of Dane.

2. That PROPOSER, BIDDER OR APPLICANT has: (Check One)

\_\_\_\_\_ not been found by the National Labor Relations Board ("NLRB") or the Wisconsin Employment Relations Commission ("WERC") to have violated any statute or regulation regarding labor standards or relations in the seven years prior to the date this Certification is signed.

\_\_\_\_\_ been found by the National Labor Relations Board ("NLRB") or the Wisconsin Employment Relations Commission ("WERC") to have violated any statute or regulation regarding labor standards or relations in the seven years prior to the date this Certification is signed

Date Signed: \_\_\_\_\_

\_\_\_\_\_  
Officer or Authorized Agent

\_\_\_\_\_  
Business Name

**NOTE: You can find information regarding the violations described above at:**  
[www.nlrb.gov](http://www.nlrb.gov) and <http://werc.wi.gov>.

**For Reference Dane County Ord. 28.11 (28) is as follows:**

**(28) BIDDER RESPONSIBILITY. (a)** Any bid, application or proposal for any contract with the county, including public works contracts regulated under chapter 40, shall include a certification indicating whether the bidder has been found by the National Labor Relations Board (NLRB) or the Wisconsin Employment Relations Committee (WERC) to have violated any statute or regulation regarding labor standards or relations within the last seven years. The purchasing manager shall investigate any such finding and make a recommendation to the committee, which shall determine whether the conduct resulting in the finding affects the bidder's responsibility to perform the contract.

**If you indicated that you have been found by the NLRB or WERC to have such a violation, you must include a copy of any relevant information regarding such violation with your proposal, bid or application.**



# DANE COUNTY DEPARTMENT of PUBLIC WORKS, HIGHWAY and TRANSPORTATION

County Executive  
Joseph T. Parisi

1919 Alliant Energy Center Way • Madison, Wisconsin 53713  
Phone: (608) 266-4018 • FAX: (608) 267-1533

Commissioner / Director  
Gerald J. Mandli

## BEST VALUE CONTRACTING APPLICATION

### CONTRACTORS / LICENSURE APPLICANTS

The Dane County Department of Public Works requires all contractors to be pre-qualified as a best value contractor with the County prior to being awarded a contract. In addition, the County pre-qualifies potential contractors and sub-contractors who wish to work on County contracts. Subcontractors must become pre-qualified ten (10) days prior to commencing work under any Dane County Public Works Contract. Potential subcontractors are urged to become pre-qualified as early as possible. This document shall be completed, properly executed, along with the necessary attachments and additional information that the County requires for the protection and welfare of the public in the performance of a County contract.

Contractors or subcontractors of any tier who attain pre-qualification status will retain that status for a period of two (2) years from the date of qualification. Contractors shall notify the Dane County Department of Public Works, Highway & Transportation within fifteen (15) days of any changes to its business or operations that are relevant to the pre-qualification application. Failure to do so could result in suspension, revocation of the contractor's pre-qualification, debarment from County contracts for up to three (3) years and / or other sanctions available under the law.

No contracts will be awarded for construction work performed on Dane County projects unless the contractor is currently approved as a Wisconsin Trade Trainer or has applied for approval as an Apprenticeship Trade Trainer to the Wisconsin Department of Workforce Development and agrees to an acceptable apprenticeship program. If you are not currently approved as a Wisconsin Trade Trainer, or have not applied for approval as an Apprenticeship Trade Trainer, please contact the Department of Workforce Development - Bureau of Apprenticeship Standards at 608/266-3133 or visit their web site at: [dwd.wisconsin.gov/apprenticeship/](http://dwd.wisconsin.gov/apprenticeship/).

### EXEMPTIONS

- Contractors who employ less than five (5) apprenticeable trade workers are not required to pre-qualify.
- Contractors performing work that does not apply to an apprenticeable trade, as outlined in Appendix A.
- The contractor / subcontractor provides sufficient documentation to demonstrate one or more of the following:
  - apprentices are not available in a specific geographic area;
  - the applicable apprenticeship program is unsuitable or unavailable; or
  - there is a documented depression of the local construction market which prevents compliance.

SEC.	PROOF OF RESPONSIBILITY	CHECK IF APPLICABLE
1	Does your firm possess all technical qualifications and resources, including equipment, personnel and financial resources, necessary to perform the work required for any project or obtain the same through the use of responsible, pre-qualified subcontractors?	Yes: <input type="checkbox"/> No: <input type="checkbox"/>
2	Will your firm possess all valid, effective licenses, registrations or certificates required by federal, state, county, or local law, which are necessary for the type of work to be performed including, but not limited to, those for any type of trade work or specialty work?	Yes: <input type="checkbox"/> No: <input type="checkbox"/>
3	Will your firm meet all bonding requirements as required by applicable law or contract specifications?	Yes: <input type="checkbox"/> No: <input type="checkbox"/>
4	Will your firm meet all insurance requirements as required by applicable law or specifications, including general liability insurance, workers compensation insurance and unemployment insurance requirements?	Yes: <input type="checkbox"/> No: <input type="checkbox"/>
5	Will your firm maintain a substance abuse policy for employees hired for public works contracts that comply with Wis. Stats. Sec. 103.503?	Yes: <input type="checkbox"/> No: <input type="checkbox"/>
6	Does your firm acknowledge that it must pay all craft employees on public works projects the wage rates and benefits required under Section 66.0903 of the Wisconsin Statutes?	Yes: <input type="checkbox"/> No: <input type="checkbox"/>
7	Will your firm fully abide by the equal opportunity and affirmative action requirements of all applicable laws, including County ordinances?	Yes: <input type="checkbox"/> No: <input type="checkbox"/>
8	In the past three (3) years, has your firm had control or has another corporation, partnership or other business entity operating in the construction industry controlled it? If so, please attach a statement explaining the nature of the firm relationship?	Yes: <input type="checkbox"/> No: <input type="checkbox"/> If Yes, attach details.
9	In the past three (3) years, has your firm had any type of business, contracting or trade license, certification or registration revoked or suspended?	Yes: <input type="checkbox"/> No: <input type="checkbox"/> If Yes, attach details.
10	In the past three (3) years, has your firm been debarred by any federal, state or local government agency?	Yes: <input type="checkbox"/> No: <input type="checkbox"/> If Yes, attach details.
11	In the past three (3) years, has your firm defaulted or failed to complete any contract?	Yes: <input type="checkbox"/> No: <input type="checkbox"/> If Yes, attach details.
12	In the past three (3) years, has your firm committed a willful violation of federal, state or local government safety laws as determined by a final decision of a court or government agency authority.	Yes: <input type="checkbox"/> No: <input type="checkbox"/> If Yes, attach details.
13	In the past three (3) years, has your firm been in violation of any law relating to your contracting business where the penalty for such violation resulted in the imposition of a penalty greater than \$10,000?	Yes: <input type="checkbox"/> No: <input type="checkbox"/> If Yes, attach details.
14	Is your firm Executive Order 108 precertified with the State of Wisconsin?	Yes: <input type="checkbox"/> No: <input type="checkbox"/>
15	Is your firm an active Wisconsin Trade Trainer as determined by the Wisconsin Bureau of Apprenticeship Standards?	Yes: <input type="checkbox"/> No: <input type="checkbox"/>
16	Is your firm exempt from being pre-qualified with Dane County?	Yes: <input type="checkbox"/> No: <input type="checkbox"/> If Yes, attach reason for exemption.
17	Does your firm acknowledge that in doing work under any County Public Works Contract, it will be required to use as subcontractors only those contractors that are also pre-qualified with the County or become so ten days prior to commencing work?	Yes: <input type="checkbox"/> No: <input type="checkbox"/>
18	Contractor has been in business less than one year	Yes: <input type="checkbox"/> No: <input type="checkbox"/>
19	First time Contractor requesting a one time exemption, but, intends to comply on all future contracts and is taking steps typical of a "good faith" effort	Yes: <input type="checkbox"/> No: <input type="checkbox"/>

20	Not applicable. My firm does not intend to work on Best Value Contracts, Note: Best Value contracting is required to bid on most Public Works Contracts. (If unclear, please call Jan Neitzel Knox 608-266-4029)	Yes: <input type="checkbox"/> No: <input type="checkbox"/>
----	--	--

**SIGNATURE SECTION**

Your firm's Officer, or the individual who would sign a bid and / or contract documents must sign this document.

I do hereby certify that all statements herein contained are true and correct to the best of my knowledge:

\_\_\_\_\_  
Signature Date

\_\_\_\_\_  
Printed or Typed Name and Title

NAME AND ADDRESS OF CONTRACTOR	
Name of Firm:	
Address:	
City, State, Zip:	
Telephone Number:	
Fax Number:	
E-mail Address:	

**REMEMBER!**

**Return all to forms and attachments, or questions to:**

**JAN NEITZEL KNOX  
EMAIL: NEITZEL-KNOX@COUNTYOFDANE.COM  
OFFICE: (608)266-4029, FAX: (608)267-1533**

**DANE COUNTY DEPARTMENT OF PUBLIC WORKS,  
HIGHWAY & TRANSPORTATION  
1919 ALLIANT ENERGY CENTER WAY  
MADISON, WI 53713**



# APPENDIX A

## APPRENTICEABLE TRADES

Bricklayer  
Carpenter  
Cement Mason (Concrete Finisher)  
Cement Mason (Heavy Highway)  
Construction Craft Laborer  
Data Communications Installer  
Electrician  
Elevator Mechanic / Technician  
Environmental Systems Technician / HVAC Service Technician / HVAC Install & Service  
Glazier  
Heavy Equipment Operator / Operating Engineer  
Insulation Worker (Heat & Frost)  
Iron Worker (Assembler, Metal Buildings)  
Painter / Decorator  
Plasterer  
Plumber  
Roofer / Waterproofer  
Sheet Metal Worker  
Sprinkler Fitter  
Steamfitter (Service & Refrigeration)  
Taper & Finisher  
Telecommunications (Voice, Data & Video) Installer / Technician  
Tile Setter

**COUNTY OF DANE**

**PUBLIC WORKS CONTRACT**

Contract No. \_\_\_\_\_ Bid No. 314002

Authority: Res. \_\_\_\_\_,

**THIS CONTRACT**, made and entered into as of the date by which authorized representatives of both parties have affixed their signatures, by and between the County of Dane (hereafter referred to as "COUNTY") and \_\_\_\_\_ (hereafter, "CONTRACTOR"), and

**WITNESSETH:**

**WHEREAS**, COUNTY, whose address is c/o Associate Public Works Director, 1919 Alliant Energy Center Way, Madison, WI 53713, desires to have CONTRACTOR provide Clay Excavation and Trucking at 7102 U.S. Highway 12 & 18 Madison, WI ("the Project"); and

**WHEREAS**, CONTRACTOR, whose address is \_\_\_\_\_ is able and willing to construct the Project, in accordance with the Construction Documents;

**NOW, THEREFORE**, in consideration of the above premises and the mutual covenants of the parties hereinafter set forth, the receipt and sufficiency of which is acknowledged by each party for itself, COUNTY and CONTRACTOR do agree as follows:

1. CONTRACTOR agrees to construct, for the price of \$ \_\_\_\_\_ the Project and at the CONTRACTOR'S own proper cost and expense to furnish all materials, supplies, machinery, equipment, tools, superintendence labor, insurance, and other accessories and services necessary to complete the Project in accordance with the conditions and prices stated in the Bid Form, General Conditions of Contract, the drawings which include all maps, plats, plans, and other drawings and printed or written explanatory matter thereof, and the specifications therefore as prepared by JSD Professional Services Inc. (hereinafter referred to as "the Architect / Engineer"), and as enumerated in the Project Manual Document Index, all of which are made a part hereof and collectively evidence and constitute the Contract.
2. COUNTY agrees to pay the CONTRACTOR in current funds for the performance of the Contract subject to additions and deductions, as provided in the General Conditions of Contract and to make payments on account thereof as provided in Article entitled, "Payments to Contractor" of the General Conditions of Contract.
3. During the term of this Contract, CONTRACTOR agrees to take affirmative action to ensure equal employment opportunities. The CONTRACTOR agrees in accordance with Wisconsin Statute 111.321 and Chapter 19 of the Dane County Code of Ordinances not to discriminate on the basis of age, race, ethnicity, religion, color, gender, disability, marital status, sexual orientation, national origin, cultural differences, ancestry, physical appearance, arrest record or conviction record, military participation or membership in the national guard, state defense force

or any other reserve component of the military forces of the United States, or political beliefs. Such equal opportunity shall include, but not be limited to, the following: employment, upgrading, demotion, transfer, recruitment, advertising, layoff, termination, training, rates of pay, and any other form of compensation. CONTRACTOR agrees to post in conspicuous places, available to all employees and applicants for employment, notices setting forth the provisions of this paragraph.

**4.** CONTRACTOR shall file an Affirmative Action Plan with the Dane County Contract Compliance Officer in accord with Chapter 19 of the Dane County Code of Ordinances. CONTRACTOR must file such plan within fifteen (15) days of the effective date of this Contract. During the term of this Contract CONTRACTOR shall also provide copies of all announcements of employment opportunities to COUNTY'S Contract Compliance Office, and shall report annually the number of persons, by race, ethnicity, gender, and disability status, which apply for employment and, similarly classified, the number hired and number rejected.

**5.** During the term of this Contract, all solicitations for employment placed on CONTRACTOR'S behalf shall include a statement to the effect that CONTRACTOR is an "Equal Opportunity Employer."

**6.** CONTRACTOR agrees to comply with provisions of Chapter 25.016 of the Dane County Code of Ordinances, which pertains to domestic partnership benefits.

**7.** CONTRACTOR agrees to furnish all information and reports required by COUNTY'S Contract Compliance Officer as the same relate to affirmative action and nondiscrimination, which may include any books, records, or accounts deemed appropriate to determine compliance with Chapter 19, Dane County Code of Ordinances, and the provisions of this Contract.

**8.** CONTRACTOR agrees that all persons employed by CONTRACTOR or any subcontractor shall be paid no less than the minimum wage established under Chapter 40, Subchapter II, Dane County Code of Ordinances. CONTRACTOR agrees to abide by and comply with the provisions of Chapter 40, Subchapter II of the Dane County Code of Ordinances, and said Subchapter is fully incorporated herein by reference.

**9.** This Contract is intended to be a Contract solely between the parties hereto and for their benefit only. No part of this Contract shall be construed to add to, supplement, amend, abridge or repeal existing rights, benefits or privileges of any third party or parties including, but not limited to, employees of either of the parties.

**10.** The entire agreement of the parties is contained herein and this Contract supersedes any and all oral agreements and negotiations between the parties relating to the subject matter hereof. The parties expressly agree that the express terms of this Contract shall not be amended in any fashion except in writing, executed by both parties.

**11.** CONTRACTOR must be pre-qualified as a Best Value Contractor with Dane County Public Works Engineering Division before award of Contract. Subcontractors must be pre-qualified ten (10) days prior to commencing Work under this Contract.

**IN WITNESS WHEREOF**, COUNTY and CONTRACTOR, by their respective authorized agents, have caused this Contract and its Schedules to be executed, effective as of the date by which all parties hereto have affixed their respective signatures, as indicated below.

\* \* \* \* \*

**FOR CONTRACTOR:**

\_\_\_\_\_  
Signature Date

\_\_\_\_\_  
Printed or Typed Name and Title

\_\_\_\_\_  
Signature Date

\_\_\_\_\_  
Printed or Typed Name and Title

NOTE: If CONTRACTOR is a corporation, Secretary should attest. In accordance with IRS Regulations, unincorporated entities are required to provide either their Social Security or Employer Number in order to receive payment for services rendered.

\* \* \* \* \*

This Contract is not valid or effectual for any purpose until approved by the appropriate authority designated below, and no work is authorized until the CONTRACTOR has been given notice to proceed by COUNTY'S Associate Public Works Director.

**FOR COUNTY:**

\_\_\_\_\_  
Joseph T. Parisi, County Executive Date

\_\_\_\_\_  
Karen Peters, County Clerk Date

THE AMERICAN INSTITUTE OF ARCHITECTS



AIA Document A310

Bid Bond

Bond No.

KNOW ALL MEN BY THESE PRESENTS, that we (Here insert full name and address or legal title of Contractor)

as Principal, hereinafter called the Principal, and (Here insert full name and address or legal title of Surety)

a corporation duly organized under the laws of the State of WI as Surety, hereinafter called the Surety, are held and firmly bound unto (Here insert full name and address or legal title of Owner)

as Obligee, hereinafter called Obligee, in the sum of ( ) Percent of total amount bid Dollars (\$) Percent of attached bid.

For the payment of which sum well and truly to be made, the said Principal and the said Surety, bind ourselves, our heirs, executors, administrators, successors and assigns, jointly and severally, firmly by these presents.

WHEREAS, the Principal has submitted a bid for Project No.: (Here insert full name, address, and description of project)

NOW, THEREFORE, if the Obligee shall accept the bid of the Principal and the Principal shall enter into a Contract with the Obligee in accordance with the terms of such bid, and give such bond or bonds as may be specified in the bidding or Contract Documents with good and sufficient surety for the faithful performance of such Contract and for the prompt payment of labor and material furnished in the prosecution thereof, or in the event of the failure of the Principal to enter such Contract and give such bond or bonds, if the Principal shall pay to the Obligee the difference not to exceed the penalty hereof between the amount specified in said bid and such larger amount for which the Obligee may in good faith contract with another party to perform the Work covered by said bid, then this obligation shall be null and void, otherwise to remain in full force and effect.

Signed and sealed this day of , 20 .

(Witness) (Principal) (Seal) (Title) (Surety) (Seal) (Witness) ATTORNEY-IN-FACT

THE AMERICAN INSTITUTE OF ARCHITECTS



Bond No. \_\_\_\_\_

AIA Document A312

**Performance Bond**

Any singular reference to Contractor, Surety, Owner or other party shall be considered plural where applicable.

CONTRACTOR (Name and Address): \_\_\_\_\_

SURETY (Name and Principal Place of Business): \_\_\_\_\_

OWNER (Name and Address): \_\_\_\_\_

CONSTRUCTION CONTRACT  
Date: \_\_\_\_\_  
Amount: \$ \_\_\_\_\_  
Description (Name and Location): \_\_\_\_\_

BOND

Date (Not earlier than Construction Contract Date): \_\_\_\_\_

Amount: \$ \_\_\_\_\_

Modifications to this Bond: \_\_\_\_\_

None

See Page 3

CONTRACTOR AS PRINCIPAL  
COMPANY: \_\_\_\_\_  
(Corporate Seal)

SURETY COMPANY: \_\_\_\_\_  
(Corporate Seal)

Signature: \_\_\_\_\_  
Name and Title:

Signature: \_\_\_\_\_  
Name and Title:

Attorney-in-Fact

(Any additional signatures appear on page 3)

FOR INFORMATION ONLY-Name, Address and Telephone  
AGENT OR BROKER: \_\_\_\_\_

OWNER'S REPRESENTATIVE (Architect,  
Engineer or other party): \_\_\_\_\_

1. The Contractor and the Surety, jointly and severally, bind themselves, their heirs, executors, administrators, successors, and assigns to the Owner for the performance of the Construction Contract, which is incorporated herein by reference.

2. If the Contractor performs the Construction Contract, the Surety and the Contractor shall have no obligation under this Bond, except to participate in conferences as provided in Subparagraph 3.1.

3. If there is no Owner Default, the Surety's obligation under this Bond shall arise after:

3.1 The Owner has notified the Contractor and the Surety at its address described in Paragraph 10 below that the Owner is considering declaring a Contractor Default and has requested and attempted to arrange a conference with the Contractor and the Surety to be held not later than fifteen days after receipt of such notice to discuss methods of performing the Construction Contract. If the Owner, the Contractor and the Surety agree, the Contractor shall be allowed a reasonable time to perform the Construction Contract, but such an agreement shall not waive the Owner's right, if any, subsequently to declare a Contractor Default; and

3.2 The Owner has declared a Contractor Default and formally terminated the Contractor's right to complete the contract. Such Contractor Default shall not be declared earlier than twenty days after the Contractor and the Surety have received notice as provided in Subparagraph 3.1; and

3.3 The Owner has agreed to pay the Balance of the Contract Price to the Surety in accordance with the terms of the Construction Contract or to a contractor selected to perform the Construction Contract in accordance with the terms of the contract with the Owner.

4. When the Owner has satisfied the conditions of Paragraph 3, the Surety shall promptly and at the Surety's expense take one of the following actions:

4.1 Arrange for the Contractor, with consent of the Owner, to perform and complete the Construction Contract; or

4.2 Undertake to perform and complete the Construction Contract itself, through its agents or through independent contractors; or

4.3 Obtain bids or negotiated proposals from qualified contractors acceptable to the Owner for a contract for performance and completion of the Construction Contract, arrange for a contract to be prepared for execution by the Owner and the contractor selected with the Owner's concurrence, to be secured with performance and payment bonds executed by a qualified surety equivalent to the bonds issued on the Construction Contract, and pay to the Owner the amount of damages as described in Paragraph 6 in excess of the Balance of the Contract Price incurred by the Owner resulting from the Contractor's default; or

4.4 Waive its rights to perform and complete, arrange for completion, or obtain a new contractor and with reasonable promptness under the circumstances:

1. After investigation, determine the amount for

which it may be liable to the Owner and, as soon as practicable after the amount is determined, tender payment therefor to the Owner; or

2. Deny liability in whole or in part and notify the Owner citing reasons therefor.

5. If the Surety does not proceed as provided in Paragraph 4 with reasonable promptness, the Surety shall be deemed to be in default on this Bond fifteen days after receipt of an additional written notice from the Owner to the Surety demanding that the Surety perform its obligations under this Bond, and the Owner shall be entitled to enforce any remedy available to the Owner. If the Surety proceeds as provided in Subparagraph 4.4, and the Owner refuses the payment tendered or the Surety has denied liability, in whole or in part, without further notice the Owner shall be entitled to enforce any remedy available to the Owner.

6. After the Owner has terminated the Contractor's right to complete the Construction Contract, and if the Surety elects to act under Subparagraph 4.1, 4.2, or 4.3 above, then the responsibilities of the Surety to the Owner shall not be greater than those of the Contractor under the Construction Contract, and the responsibilities of the Owner to the Surety shall not be greater than those of the Owner under the Construction Contract. To the limit of the amount of this Bond, but subject to commitment by the Owner of the Balance of the Contract Price to mitigation of costs and damages on the Construction Contract, the Surety is obligated without duplication for:

6.1 The responsibilities of the Contractor for correction of defective work and completion of the Construction Contract;

6.2 Additional legal, design professional and delay costs resulting from the Contractor's Default, and resulting from the actions or failure to act of the Surety under Paragraph 4; and

6.3 Liquidated damages, or if no liquidated damages are specified in the Construction Contract, actual damages caused by delayed performance or non-performance of the Contractor.

7. The Surety shall not be liable to the Owner or others for obligations of the Contractor that are unrelated to the Construction Contract, and the Balance of the Contract Price shall not be reduced or set off on account of any such unrelated obligations. No right of action shall accrue on this Bond to any person or entity other than the Owner or its heirs, executors, administrators, or successors.

8. The Surety hereby waives notice of any change, including changes of time, to the Construction Contract or to related subcontracts, purchase orders and other obligations.

9. Any proceeding, legal or equitable, under this Bond may be instituted in any court of competent jurisdiction in the location in which the work or part of the work is located and shall be instituted within two years after Contractor Default or within two years after the Contractor ceased working or within two years after the Surety refuses or fails to perform its obligations under this Bond, whichever occurs first. If the provisions of this Paragraph are void or prohibited by law, the minimum period of limitation available to sureties as a defense in the jurisdiction of the suit shall be applicable.

10. Notice to the Surety, the Owner or the Contractor shall be mailed or delivered to the address shown on the signature page.

11. When this Bond has been furnished to comply with a statutory or other legal requirement in the location where the construction was to be performed, any provision in this Bond conflicting with said statutory or legal requirement shall be deemed deleted here from and provisions conforming to such statutory or other legal requirement shall be deemed incorporated herein. The intent is that this Bond shall be construed as a statutory bond and not as a common law bond.

**12 DEFINITIONS**

12.1 Balance of the Contract Price: The total amount payable by the Owner to the Contractor under the Construction Contract after all proper adjustments have been made, including allowance to the Contractor of any amounts received or to be received by the Owner in settlement of insurance or other

claims for damages to which the Contractor is entitled, reduced by all valid and proper payments made to or on behalf of the Contractor under the Construction Contract.

12.2 Construction Contract: The agreement between the Owner and the Contractor identified on the signature page, including all Contract Documents and changes thereto.

12.3 Contractor Default: Failure of the Contractor, which has neither been remedied nor waived, to perform or otherwise to comply with the terms of the Construction Contract.

12.4 Owner Default: Failure of the Owner, which has neither been remedied nor waived, to pay the Contractor as required by the Construction Contract or to perform and complete or comply with the other terms thereof.

**MODIFICATIONS TO THIS BOND ARE AS FOLLOWS:**

SAMPLE

(Space is provided below for additional signatures of added parties, other than those appearing on the cover page.)

CONTRACTOR AS PRINCIPAL  
Company: (Corporate Seal)

SURETY  
Company: (Corporate Seal)

Signature: \_\_\_\_\_  
Name and Title:  
Address:

Signature: \_\_\_\_\_  
Name and Title:  
Address:



THE AMERICAN INSTITUTE OF ARCHITECTS



Bond No. \_\_\_\_\_

AIA Document A312

Payment Bond

Any singular reference to Contractor, Surety, Owner or other party shall be considered plural where applicable.

CONTRACTOR (Name and Address):

SURETY (Name and Principal Place of Business):

OWNER (Name and Address):

CONSTRUCTION CONTRACT  
Date:  
Amount: \$  
Description (Name and Location):

BOND

Date (Not earlier than Construction Contract Date):

Amount: \$

Modifications to this Bond:

None

See Page 6

CONTRACTOR AS PRINCIPAL  
COMPANY: (Corporate Seal)

SURETY COMPANY:  
(Corporate Seal)

Signature: \_\_\_\_\_  
Name and Title:

Signature: \_\_\_\_\_  
Name and Title:  
Attorney-in-Fact

(Any additional signatures appear on page 6)

FOR INFORMATION ONLY-Name, Address and Telephone  
AGENT OR BROKER:

OWNER'S REPRESENTATIVE (Architect,  
Engineer or other party):

1. The Contractor and the Surety, jointly and severally, bind themselves, their heirs, executors, administrators, successors, and assigns to the Owner to pay for labor, materials and equipment furnished for use in the performance of the Construction Contract, which is incorporated herein by reference.

2. With respect to the Owner, this obligation shall be null and void if the Contractor:

2.1 Promptly makes payment, directly, or indirectly, for all sums due Claimants, and

2.2 Defends, indemnifies and holds harmless the Owner from claims, demands, liens or suits by any person or entity whose claim, demand, lien or suit is for the payment for labor, materials, or equipment furnished for use in the performance of the Construction Contract, provided the Owner has promptly notified the Contractor and the Surety (at the address described in Paragraph 12) of any claims, demands, liens, or suits and tendered defense of such claims, demands, liens or suits to the Contractor and the Surety, and provided there is no Owner Default.

3. With respect to Claimants, this obligation shall be null and void if the Contractor promptly makes payment, directly or indirectly, for all sums due.

4. The Surety shall have no obligation to Claimants under this Bond until:

4.1 Claimants who are employed by or have a direct contract with the Contractor have given notice to the Surety (at the address described in Paragraph 12) and sent a copy, or notice thereof, to the Owner, stating that a claim is being made under this Bond and, with substantial accuracy, the amount of the claim.

4.2 Claimants who do not have a direct contract with the Contractor:

1. Have furnished written notice to the Contractor and sent a copy, or notice thereof, to the Owner, within 90 days after having last performed labor or last furnished materials or equipment included in the claim stating, with substantial accuracy, the amount of the claim and the name of the party to whom the materials were furnished or supplied or for whom the labor was done or performed; and
2. Have either received a rejection in whole or in part from the Contractor, or not received within 30 days of furnishing the above notice any communication from the Contractor by which the Contractor has indicated the claim will be paid directly or indirectly; and
3. Not having been paid within the above 30 days, have sent a written notice to the Surety (at the address described in Paragraph 12) and sent a copy, or notice thereof, to the Owner, stating that a claim is being made under this Bond and enclosing a copy of the previous written notice furnished to the Contractor.

5. If a notice required by Paragraph 4 is given by the Owner to the Contractor or to the Surety, that is sufficient compliance.

6. When the Claimant has satisfied the conditions of Paragraph 4, the Surety shall promptly and at the Surety's expense take the following actions:

6.1 Send an answer to the Claimant, with a copy to the Owner, within 45 days after receipt of the claim, stating the amounts that are undisputed and the basis for challenging any amounts that are disputed.

6.2 Pay or arrange for payment of any undisputed amounts.

7. The Surety's total obligation shall not exceed the amount of this Bond, and the amount of this Bond shall be credited for any payments made in good faith by the Surety.

8. Amounts owed by the Owner to the Contractor under the Construction Contract shall be used for the performance of the Construction Contract and to satisfy claims, if any, under any Construction Performance Bond. By the Contractor furnishing and the Owner accepting this Bond, they agree that all funds earned by the Contractor in the performance of the Construction Contract are dedicated to satisfy obligations of the Contractor and the Surety under this Bond, subject to the Owner's priority to use the funds for the completion of the work.

9. The Surety shall not be liable to the Owner, Claimants or others for obligations of the Contractor that are unrelated to the Construction Contract. The Owner shall not be liable for payment of any costs or expenses of any Claimant under this Bond, and shall have under this Bond no obligations to make payments to, give notices on behalf of, or otherwise have obligations to Claimants under this Bond.

10. The Surety hereby waives notice of any change, including changes of time, to the Construction Contract or to related subcontracts, purchase orders and other obligations.

11. No suit or action shall be commenced by a Claimant under this Bond other than in a court of competent jurisdiction in the location in which the work or part of the work is located or after the expiration of one year from the date (1) on which the Claimant gave the notice required by Subparagraph 4.1 or Clause 4.2.3, or (2) on which the last labor or service was performed by anyone or the last materials or equipment were furnished by anyone under the Construction Contract, whichever of (1) or (2) first occurs. If the provisions of this Paragraph are void or prohibited by law, the minimum period of limitation available to sureties as a defense in the jurisdiction of the suit shall be applicable.

12. Notice to the Surety, the Owner or the Contractor shall be mailed or delivered to the address shown on the signature page. Actual receipt of notice by Surety, the Owner or the Contractor, however accomplished, shall be sufficient compliance as of the date received at the address shown on the signature page.

13. When this Bond has been furnished to comply with a statutory or other legal requirement in the location where the construction was to be performed, any provision in this Bond conflicting with said statutory or legal requirement shall be deemed deleted herefrom and provisions conforming to such statutory or other legal requirement shall be deemed incorporated herein. The intent is that this Bond shall be construed as a statutory bond and not as a common law bond.

14. Upon request by any person or entity appearing to be a potential beneficiary of this Bond, the Contractor

shall promptly furnish a copy of this Bond or shall permit a copy to be made.

**15. DEFINITIONS**

**15.1 Claimant:** An individual or entity having a direct contract with the Contractor or with a subcontractor of the Contractor to furnish labor, materials or equipment for use in the performance of the Contract. The intent of this Bond shall be to include without limitation in the terms "labor, materials or equipment" that part of water, gas, power, light, heat, oil, gasoline, telephone service or rental equipment used in the Construction Contract, architectural and engineering services required for performance of the work of the Contractor and the Contractor's

subcontractors, and all other items for which a mechanic's lien may be asserted in the jurisdiction where the labor, materials or equipment were furnished.

**15.2 Construction Contract:** The agreement between the Owner and the Contractor identified on the signature page, including all Contract Documents and changes thereto.

**15.3 Owner Default:** Failure of the Owner, which has neither been remedied nor waived, to pay the Contractor as required by the Construction Contract or to perform and complete or comply with the other terms thereof.

**MODIFICATIONS TO THIS BOND ARE AS FOLLOWS:**

SAMPLE

(Space is provided below for additional signatures of added parties, other than those appearing on the cover page.)

CONTRACTOR AS PRINCIPAL  
Company: (Corporate Seal)

SURETY  
Company: (Corporate Seal)

Signature: \_\_\_\_\_  
Name and Title:  
Address:

Signature: \_\_\_\_\_  
Name and Title:  
Address:

# GENERAL CONDITIONS OF CONTRACT

## TABLE OF CONTENTS

GENERAL CONDITIONS OF CONTRACT.....	1
1. CONSTRUCTION DOCUMENTS .....	2
2. DEFINITIONS.....	2
3. ADDITIONAL INSTRUCTIONS AND DRAWINGS .....	2
4. SHOP DRAWINGS, PRODUCT DATA AND SAMPLES.....	2
5. CUTTING AND PATCHING.....	3
6. CLEANING UP .....	4
7. USE OF SITE .....	4
8. MATERIALS AND WORKMANSHIP.....	5
9. CONTRACTOR'S TITLE TO MATERIALS.....	5
10. "OR EQUAL" CLAUSE.....	5
11. PATENTS AND ROYALTIES.....	6
12. SURVEYS, PERMITS, REGULATIONS AND TAXES.....	7
13. CONTRACTOR'S OBLIGATIONS AND SUPERINTENDENCE .....	7
14. WEATHER CONDITIONS.....	8
15. PROTECTION OF WORK AND PROPERTY .....	8
16. INSPECTION AND TESTING OF MATERIALS .....	8
17. REPORTS, RECORDS AND DATA .....	9
18. CHANGES IN THE WORK.....	9
19. EXTRAS.....	10
20. TIME FOR COMPLETION.....	10
21. CORRECTION OF WORK.....	10
22. SUBSURFACE CONDITIONS FOUND DIFFERENT.....	11
23. RIGHT OF DEPARTMENT TO TERMINATE CONTRACT.....	11
24. CONSTRUCTION SCHEDULE AND PERIODIC ESTIMATES .....	11
25. PAYMENTS TO CONTRACTOR .....	12
26. WITHHOLDING OF PAYMENTS .....	14
27. ACCEPTANCE OF FINAL PAYMENT AS RELEASE.....	14
28. PAYMENTS BY CONTRACTOR.....	14
29. CONTRACT SECURITY.....	14
30. ASSIGNMENTS.....	15
31. MUTUAL RESPONSIBILITY OF CONTRACTORS .....	15
32. SEPARATE CONTRACTS .....	15
33. SUBCONTRACTS .....	15
34. PUBLIC WORKS PROJECT ENGINEER'S AUTHORITY .....	16
35. ARCHITECT / ENGINEER'S AUTHORITY .....	16
36. STATED ALLOWANCES .....	17
37. ESTIMATES OF QUANTITIES .....	17
38. LANDS AND RIGHTS-OF-WAY.....	17
39. GENERAL GUARANTEE.....	17
40. CONFLICTING CONDITIONS .....	18
41. NOTICE AND SERVICE THEREOF.....	18
42. PROTECTION OF LIVES AND HEALTH .....	18
43. AFFIRMATIVE ACTION PROVISION AND MINORITY / WOMEN / DISADVANTAGED BUSINESS ENTERPRISES.....	18
44. COMPLIANCE WITH FAIR LABOR STANDARDS.....	19
45. DOMESTIC PARTNERSHIP BENEFITS .....	20
46. USE AND OCCUPANCY PRIOR TO ACCEPTANCE .....	20
47. MINIMUM WAGES .....	20
48. CLAIMS .....	21
49. ANTITRUST AGREEMENT .....	21
50. INSURANCE.....	21
51. WISCONSIN LAW CONTROLLING.....	23

## **1. CONSTRUCTION DOCUMENTS**

- A. Construction Documents, listed in Table of Contents of this Specification volume shall form part of this Contract and provisions of Construction Documents shall be as binding upon parties as if they were fully set forth in Contract itself.
- B. These shall also be considered as part of Construction Documents: Addenda, including additions and modifications incorporated in such addenda before execution of Contract; requests for information; construction bulletins; change orders; and written interpretations by Architect / Engineer or Public Works Project Engineer that are made after execution of Contract.
- C. Construction Documents are complementary, and what is required by one shall be as binding as if required by all. Intent of Construction Documents is to include all labor, materials and equipment necessary for proper execution of the Work.

## **2. DEFINITIONS**

- A. These terms as used in this Contract are respectively defined as follows:
  - 1. All uses of term "County" in Construction Documents shall mean Dane County.
  - 2. All uses of term "Department" in Construction Documents shall mean Department of Public Works, Highway & Transportation, which is a unit of Dane County government. Department is County agency overseeing Contract with Contractor.
  - 3. Public Works Project Engineer is appointed by and responsible to Department. Public Works Project Engineer has authority to act on behalf of Department and will sign change orders, payment requests and other administrative matters related to projects.
  - 4. Public Works Project Engineer is responsible for supervision, administration and management of field operations involved in construction phase of this Work.
  - 5. Term "Work" includes all labor, equipment and materials necessary to produce project required by Construction Documents and Scope of Work section.
  - 6. Term "Substantial Completion" is date when project or specified area of project is certified by Architect / Engineer that construction is sufficiently completed, in accordance with Construction Documents, and as modified by any subsequent changes agreed to by parties, so that County may occupy project or specified area of project for use for which it was intended subject to permit approval for occupancy.
  - 7. Contractor is person, firm, or corporation with whom County makes Contract. Though multiple contracts may be involved, Construction Documents treat them throughout as if each were of singular number.

## **3. ADDITIONAL INSTRUCTIONS AND DRAWINGS**

- A. Contractor may be furnished additional instructions and detail drawings as necessary to carry out the Work included in Contract. Additional drawings and instructions thus supplied to Contractor will coordinate with Construction Documents and will be so prepared that they can be reasonably interpreted as part thereof. Contractor shall carry out the Work in accordance with additional detail drawings and instructions.

## **4. SHOP DRAWINGS, PRODUCT DATA AND SAMPLES**

- A. Unless otherwise specified, Contractor shall submit three (3) copies of all Shop Drawings for each submission, until receiving final approval. After final approval, provide five (5) additional copies for distribution and such other copies as may be required.
- B. Contractor shall submit, on an on-going basis and as directed, Product Data such as brochures that shall contain catalog cuts and specifications of all furnished mechanical and electrical equipment. After Architect / Engineer's approval, one (1) copy shall remain in Architect / Engineer's file, one (1) kept at Department's office and one (1) kept at job site by Contractor for reference purposes.
- C. Samples shall consist of physical examples furnished by Contractor in sufficient size and quantity to illustrate materials, equipment or workmanship, and to establish standards to compare the Work.
  - 1. Submit Samples in sufficient quantity (minimum of two (2)) to permit Architect / Engineer to make all necessary tests and of adequate size showing quality, type, color range, finish, and texture. Label each Sample stating material, type, color, thickness, size, project name, and Contractor's name.
  - 2. Submit transmittal letter requesting approval, and prepay transportation charges to Architect / Engineer's office on samples forwarded.
  - 3. Materials installed shall match approved Samples.
- D. Contractor shall review Shop Drawings and place their dated stamp thereon to evidence their review and approval and shall submit with reasonable promptness and in orderly sequence to cause no delay in the Work or in work of any other contractor. At time of submission, Contractor shall inform Architect / Engineer in writing of any deviation in Shop Drawings or Samples from requirements of Construction Documents. Architect / Engineer will not consider partial lists.
- E. Architect / Engineer will review and approve or reject Shop Drawings with reasonable promptness to cause no delay. Architect / Engineer's approval shall not relieve Contractor from responsibility for errors or omission in Shop Drawings.
- F. Contractor shall not commence any work requiring Shop Drawing, Product Data or Sample submission until Architect / Engineer has approved submission. All such work shall be in accordance with approved Shop Drawings, Product Data and Samples.
- G. Contractor shall keep on site of the Work, approved or conformed copy of Shop Drawings and shall at all time give Department access thereto.
- H. By stamping and submitting Shop Drawings, Product Data and Samples, Contractor thereby represents that he or she has or will determine and verify all field measurements, field construction criteria, materials, catalog numbers, and similar data and that he or she has checked and coordinated each Shop Drawing, Product Data and Sample with requirements of the Work and of Construction Documents. Architect / Engineer shall return without examination, Shop Drawings, Product Data and Samples not so noted.
- I. All Shop Drawings from any one Contractor should be numbered consecutively and on cover sheet shall bear name and location of project, name of Contractor, date of submittal and date of each correction or revision and associated Specification section and page number.

## **5. CUTTING AND PATCHING**

- A. Contractor shall be responsible for all cutting, fitting or patching required to complete the Work or to make its parts fit together properly.
- B. Contractor shall not damage or endanger portion of the Work or fully or partially completed construction of County or separate contractors by cutting, patching or otherwise altering such construction, or by excavation. Contractor shall not cut or otherwise alter such construction by County or separate contractor except with written consent of County and of such separate contractor; such consent shall not be unreasonably withheld. Contractor shall not withhold unreasonably from County or separate contractor, Contractor's consent to cutting or otherwise altering the Work.

## **6. CLEANING UP**

- A. Contractor shall keep premises and surrounding area free from accumulation of waste materials or rubbish caused by operations under Contract. Contractor shall remove from and about the Work waste materials, rubbish, Contractor's tools, construction equipment, machinery, and surplus materials at completion of the Work. Contractor shall maintain streets and sidewalks around the Work site in clean condition. Contractor shall remove all spillage and prevent tracking of spillage arising from performance of the Work, into, out of, and within the Work site. Contractor shall establish regular maintenance program of sweeping, vacuuming and / or hosing to minimize accumulation of dirt and dust upon such areas.
- B. If Contractor fails to clean up as directed in Construction Documents, County may do so and shall charge Contractor cost thereof.
- C. Contractor shall be responsible for broken windows and glass, and at completion of the Work shall replace such damaged or broken windows and glass. After replacing damaged or broken windows and glass, Contractor shall remove all labels, wash and polish both sides of all windows and glass.
- D. In addition to general cleaning, Contractor shall perform following final cleaning for all trades at completion of the Work:
  - 1. Remove temporary protections;
  - 2. Remove marks, stains, fingerprints and other soil or dirt from painted, decorated and finished woodwork and wall surfaces;
  - 3. Remove spots, plaster, soil and paint from ceramic tile, marble and other finished materials, and wash or wipe clean;
  - 4. Clean fixtures, cabinet work and equipment, removing stains, paint, dirt and dust, and leave same in undamaged, new condition;
  - 5. Clean aluminum in accordance with recommendations of manufacturer; and
  - 6. Clean resilient floors thoroughly with well-rinsed mop containing only enough moisture to clean off any surface dirt or dust and buff dry by machine to bring surfaces to sheen.

## **7. USE OF SITE**

- A. Contractor shall provide County and Architect / Engineer access to the Work under all circumstances.
- B. Contractor shall confine operations at site to areas permitted by County, law, ordinance, permits and Construction Documents and shall not unreasonably encumber site with

materials or equipment. Contractor shall assure free, convenient, unencumbered, direct and safe access to all properties adjacent to the Work for County, its employees, invitees and guests.

## **8. MATERIALS AND WORKMANSHIP**

- A. Contractor shall perform all work and furnish all supplies and materials, machinery, equipment, facilities and means, necessary to complete the Work required by this Contract, within time specified, in accordance with provisions of Construction Documents.
- B. All equipment and materials incorporated in the Work covered by this Contract are to be new; use recycled and / or recovered materials to extent that such use is technically and economically feasible. Recovered materials are products recovered from solid waste in form identical to original form for use that is same as, or similar to original use. Recycled materials are products manufactured from solid waste.
- C. If requested, Contractor shall furnish satisfactory evidence as to kind and quality of construction materials proposed or used. Contractor shall furnish to Architect / Engineer, for approval, manufacturer name and model, performance capacities and other pertinent information of machinery, mechanical, electrical or other types of equipment, which Contractor plans to install.
- D. If not otherwise provided, materials and labor called for in this Contract shall be provided and performed in accordance with established practice and standards recognized by Architects, Engineers, Department, and construction industry.
- E. Reference to “Standard” specifications of any association or manufacturer, or codes of County authorities, intends most recent printed edition or catalog in effect on date that corresponds with date of Construction Documents.
- F. Whenever reference is made in Specifications that work shall be “performed”, “applied”, in accordance with “manufacturer’s directions or instructions”, Contractor to whom those instructions are directed shall furnish three (3) printed copies of such instructions to Architect / Engineer before execution of the Work.

## **9. CONTRACTOR’S TITLE TO MATERIALS**

- A. Contractor or any subcontractor shall not purchase materials or supplies for the Work subject to any chattel mortgage or under conditional sale contract or other agreement by which seller retains interest. Contractor warrants that all materials and supplies used in the Work are free from all liens, claims or encumbrances and Contractor has good title to them.

## **10. “OR EQUAL” CLAUSE**

- A. Whenever equipment or materials are identified on Drawings or in Specifications by reference to manufacturer’s or vendor’s name, trade name, catalog number, and other identifying information, it is intended to establish standards; and any equipment or material of other manufacturers and vendors which will perform adequately duties imposed by general design will be considered equally accepted provided equipment or material so proposed is, in opinion of Architect / Engineer, of equal substance and function. Architect /



Engineer and Department shall provide written approval before Contractor may purchase or install it.

- B. Equipment or materials of manufacturers, other than those named, may be used only upon following conditions:
1. That, in opinion of Architect / Engineer and Department, proposed material or equipment item is fully equal or superior (in design, materials, construction, workmanship, performance, finish, etc.) to named item. No compromise in quality level, however small, is acceptable.
  2. That, in substituting materials or equipment, Contractor assumes responsibility for any changes in system or for modifications required in adjacent or related work to accommodate such substitution despite Architect / Engineer's and Department's approval, and all costs growing out of approval of "or equal" items shall be responsibility of Contractor. No extra costs resulting from such approval shall become responsibility of Department, Architect / Engineer or any other separate Contractor.
  3. It shall be understood that use of materials or equipment other than those specified, or approved equal by Architect / Engineer and Department, shall constitute violation of Contract, and that Architect / Engineer and Department shall have right to require removal of such materials or equipment and their replacement with specified materials or equipment at Contractor's expense.
  4. Product and manufacturer named first in Specifications or on information shown on Drawings is basis of selection of manufactured items and equipment, particularly mechanical equipment. In using other than first named products or manufacturers, including those specified as additionally approved or acceptable, Contractor assumes responsibility for any changes in system and for modifications in any work required to accommodate them. Architect / Engineer's approval of such additionally acceptable products or manufacturers, either in Specifications or in Addendum, does not relieve Contractor from obligation to coordinate such optional products with other Contractors, whose work may be affected by them, and to pay all additional costs resulting from their inclusion into the Work. Contractor's liability shall include payment of Architect / Engineer's fees for any additional services made necessary by or directly connected to such product changes. No extra costs resulting from such changes shall become responsibility of Department, Architect / Engineer or any other separate Contractor.
- C. No request for approval of "or equal" materials will be entertained except from Contractor. Identify any request for substitution on Contractor's letter of transmittal and give reasons for substitution. Department may in its sole discretion allow substitutions of materials.

## **11. PATENTS AND ROYALTIES**

- A. If Contractor uses any design, device or material covered by letters, patent or copyright, it is mutually agreed and understood, that, without exception, contract prices shall include all royalties or costs arising from use of such design, device or materials, in any way involved in the Work.
- B. Contractor shall indemnify and save harmless County from any and all claims for infringement by reason of use of such patent or copyright in connection with the Work agreed to be performed under this Contract, and shall indemnify County for any cost, expense or damage which it may be obliged to pay by reason of such infringement at any time during prosecution of the Work or after completion of the Work.

## **12. SURVEYS, PERMITS, REGULATIONS AND TAXES**

- A. Department will furnish to Contractor all available site, topography and property surveys.
- B. Prior to commencement of the Work, Dane County shall secure Conditional Use Permit and erosion control permit. Contractor to secure any and all other permits , licenses and approvals necessary for execution of this Contract.
- C. Contractor shall give all notices and comply with all State of Wisconsin, Federal and local laws, codes, rules and regulations relating to performance of the Work, protection of adjacent property, and maintenance of passageways, guard fences or other protective facilities.
- D. Contractor shall pay all Sales, Consumer, Use and other similar taxes required by law.
- E. Contractor shall promptly notify Architect / Engineer of any variances of Drawings or Specifications with that of any State of Wisconsin, federal or local law, code, rule or regulation. Upon such notification, Architect / Engineer will require correction of variance to comply with applicable law, code, rule or regulation at no additional cost to Contractor.
- F. Work under this Contract shall comply with all applicable State of Wisconsin, Federal and local laws, codes and regulations.
- G. Contractor shall pay charges for water, sewer and other utility connections made by municipalities where required by Specifications.

## **13. CONTRACTOR'S OBLIGATIONS AND SUPERINTENDENCE**

- A. Contractor shall provide and pay for all materials, labor, tools, equipment, transportation and superintendence necessary to execute, complete and deliver the Work within specified time. Contractor agrees to secure at their own expense all personnel necessary to carry out the Work. Such personnel shall not be deemed County employees nor shall they have or be deemed to have any direct contractual relationship with County.
- B. Performance of any work necessary after regular working hours, on Sundays or Legal Holidays shall be without additional expense to County. Performance of any work at site at other than normal working hours must be coordinated with Public Works Project Engineer.
- C. Contractor shall furnish, erect, maintain and remove such temporary works as may be required.
- D. Contractor shall observe, comply with, and be subject to all terms, conditions, requirements and limitations of Construction Documents.
- E. At the Work site, Contractor shall give personal superintendence to the Work or shall employ construction superintendent or foreman, experienced in character of work covered by Contract, who shall have full authority to act for Contractor. Understand that such superintendent or foreman shall be acceptable to Architect / Engineer and Department.
- F. Remove from project or take other corrective action upon notice from Architect / Engineer or Department for Contractor's employees whose work is considered by Architect / Engineer or Department to be unsatisfactory, careless, incompetent, unskilled or otherwise objectionable.

- G. Contractor and subcontractors shall be required to conform to Labor Laws of State of Wisconsin and various acts amendatory and supplementary thereto and to other laws, ordinances and legal requirements applicable to the Work.
- H. Presence and observation of the Work by Architect / Engineer or Public Works Project Engineer shall not relieve Contractor of any obligations.

#### **14. WEATHER CONDITIONS**

- A. In event of temporary suspension of work, or during inclement weather, or whenever Architect / Engineer shall direct, Contractor shall, and shall cause subcontractors to protect carefully all work and materials against damage or injury from weather. If, in opinion of Architect / Engineer or Department, any work or materials that have been damaged or injured due to failure on part of Contractor or any subcontractors so to protect the Work, such materials shall be removed and replaced at expense of Contractor.

#### **15. PROTECTION OF WORK AND PROPERTY**

- A. Contractor shall at all times safely guard County's property from injury or loss in connection with this Contract. Contractor shall at all times safely guard and protect the Work, and adjacent property, from damage. Contractor shall replace or make good any such damage, loss or injury unless such be caused directly by errors contained in Contract, or by County, or County's duly authorized representative.
- B. Contractor may act diligently, without previous instructions from Architect / Engineer and / or Department, in emergency that threatens loss or injury of property, or safety of life. Contractor shall notify Architect / Engineer and / or Department immediately thereafter. Promptly submit any claim for compensation by Contractor due to such extra work to Architect / Engineer and / or Department for approval as provided for in Article 18 herein.

#### **16. INSPECTION AND TESTING OF MATERIALS**

- A. Authorized representatives and agents of County government shall have access at all times to the Work wherever it is in preparation or progress and Contractor shall provide facilities for such access and for inspection.
- B. Should it be considered necessary or advisable at any time before final acceptance of the Work to make examination of work already completed, by removing or tearing out same, Contractor shall upon request, promptly furnish all necessary facilities, labor and materials. If such work is found to be defective in any aspect, due to fault of Contractor or subcontractors thereof, Contractor shall assume all expenses of such examination and of satisfactory reconstruction. Contractor will be reimbursed for such examination and replacement in accordance with Article 18 - A.3., of these General Conditions of Contract if such work is found to meet requirements of Contract.
- C. If Specifications, Architect / Engineer's, or Public Works Project Engineer's instructions require any work to be specially tested or approved, Contractor shall give Architect / Engineer and Public Works Project Engineer timely notice of its readiness for testing or inspection. Test all materials and equipment requiring testing in accordance with accepted or specified standards, as applicable. Architect / Engineer shall recommend laboratory or inspection agency and Department will select and pay for all initial laboratory inspection

services. Should retesting be required, due to failure of initial testing, cost of such retesting shall be borne by Contractor.

- D. Cost of any testing performed by manufacturers or Contractor for substantiating acceptability of proposed substitution of materials and equipment, or necessary conformance testing in conjunction with manufacturing processes or factory assemblage, shall be borne by Contractor or manufacturer responsible.

## **17. REPORTS, RECORDS AND DATA**

- A. Contractor shall submit to Architect / Engineer and Public Works Project Engineer such schedule of quantities and costs, progress schedules, payrolls, reports, estimates, invoices, records and other data as either may request concerning work performed or to be performed under this Contract.

## **18. CHANGES IN THE WORK**

- A. Make no changes, except in cases of emergency, in the Work covered by approved Construction Documents without having prior written approval of Department. Charges or credits for the Work covered by approved change shall be determined by one of these methods:
1. Unit bid prices previously approved.
  2. Agreed lump sum based on actual cost of:
    - a) Labor, including foremen, and all fringe benefits that are associated with their wages.
    - b) Materials entering permanently into the Work.
    - c) Ownership or rental cost of construction tools and equipment during time of use on extra work.
    - d) Power and consumable supplies for operation of power equipment.
    - e) Workmen's Compensation Insurance, Contractor's Public Liability and Property Damage Insurance, and Comprehensive Automobile Liability Insurance.
    - f) Social Security and old age and unemployment contributions.
    - g) Add to cost under (2), fixed fee to be agreed upon, but not to exceed fifteen percent (15%) of actual cost of work performed with their own labor force. Fee shall be compensation to cover cost of supervision, overhead, bond, profit and any other general expense.
    - h) On that portion of the Work under (2) done under subcontract, Contractor may include not over seven and one-half percent (7½%) for supervision, overhead, bond, profit and any other general expense.
    - i) Department may require correct amount of costs with supporting vouchers; Contractor shall keep and present in such form as directed.
  3. Cost-plus work, with not-to-exceed dollar limit, based on actual cost of:
    - a) Labor, including foremen, and all fringe benefits that are associated with their wages.
    - b) Materials entering permanently into the Work.
    - c) Ownership or rental cost of construction tools and equipment during time of use on extra work. Rental cost cannot exceed fifty percent (50%) replacement value of rented equipment.
    - d) Power and consumable supplies for operation of power equipment.
    - e) Workmen's Compensation Insurance, Contractor's Public Liability and Property Damage Insurance, and Comprehensive Automobile Liability Insurance.

- f) Social Security and old age and unemployment contributions.
  - g) To cost under (3), there shall be added fixed fee to be agreed upon but not to exceed fifteen percent (15%) of actual cost of work performed with their own labor force. Fee shall be compensation to cover cost of supervision, overhead, bond, profit, and any other general expense.
  - h) On that portion of the Work under (3) done under subcontract, Contractor may include not over seven and one-half percent (7½%) for supervision, overhead, bond, profit, and any other general expense.
  - i) Contractor shall keep and present, in such form as directed, correct amount of cost together with such supporting vouchers as may be required by Department.
- B. If Contractor claims that by any instructions given by Architect / Engineer, Department, by drawings or otherwise, regarding performance of the Work or furnishing of material under Contract, involves extra cost, Contractor shall give Department written notice of cost thereof within two (2) weeks after receipt of such instructions and in any event before proceeding to execute work, unless delay in executing work would endanger life or property.
- C. No claim for extra work or cost shall be allowed unless it was done in pursuance of written Change Order from Architect / Engineer and approved by Department, as previously mentioned, and claim presented with payment request submitted after changed or extra work is completed.
- D. Negotiation of cost for change in the Work shall not be cause for Contractor to delay prosecution of the Work if Contractor has been authorized in writing by Public Works Project Engineer to proceed.

## **19. EXTRAS**

- A. Without invalidating Contract, Department may order extra work or make changes by altering, adding to or deducting from the Work, contract sum being adjusted in accordance with Article 18 herein.

## **20. TIME FOR COMPLETION**

- A. Contractor agrees that the Work shall be prosecuted regularly and diligently and complete the Work as stated in Construction Documents.

## **21. CORRECTION OF WORK**

- A. All work, all materials whether incorporated in the Work or not, and all processes of manufacture shall at all times and places be subject to inspection of Architect / Engineer and Public Works Project Engineer who shall be judge of quality and suitability of the Work, materials, and processes of manufacture for purposes for which they are used. Should they fail to meet Architect / Engineer's and Public Works Project Engineer's approval they shall be reconstructed, made good, replaced or corrected, by Contractor at Contractor's expense. Immediately remove all rejected material from site.
- B. If Contractor defaults or neglects to carry out the Work in accordance with Construction Documents or fails to perform any provision of Contract, Department may, after ten (10) days' written notice to Contractor and without prejudice to any other remedy County may have, make good such deficiencies. In such case, appropriate Change Order shall be issued

deducting from Contractor's payments then or thereafter, cost of correcting such deficiencies, including cost of Architect / Engineer's additional services made necessary by such default, neglect or failure.

## **22. SUBSURFACE CONDITIONS FOUND DIFFERENT**

- A. If Contractor encounters subsurface or latent conditions at site materially differing from those shown on Drawings or indicated in Specifications, Contractor shall immediately give notice to Architect / Engineer and Public Works Project Engineer of such conditions before they are disturbed. Architect / Engineer will thereupon promptly investigate conditions, and if Architect / Engineer finds that they materially differ from those shown on Drawings or indicated in Specifications, Architect / Engineer will at once make such changes as necessary, any increase or decrease of cost resulting from such changes to be adjusted in manner provided in above Article 18 entitled "Changes in the Work".

## **23. RIGHT OF DEPARTMENT TO TERMINATE CONTRACT**

- A. In event that any provisions of this Contract are violated by Contractor or by any subcontractors, County may serve written notice upon Contractor and Surety of its intention to terminate Contract, such notice to contain reasons for such intention to terminate Contract, and unless within ten (10) days after serving of such notice upon Contractor, such violation or delay shall cease and satisfactory arrangement or correction be made, Contract shall, upon expiration of said ten (10) days, cease and terminate.
- B. In event of any such termination, County shall immediately serve notice thereof upon Surety and Contractor, and Surety shall have right to take over and perform Contract subject to County's approval; provided, however, that if Surety does not commence performance thereof within ten (10) days from date of mailing to such Surety of notice of termination, County may take over the Work and prosecute same to completion by contract, or by force account, at expense of Contractor; Contractor and Surety shall be liable to County for any excess cost occasioned County thereby, and in such event County may take possession of and utilize in completing the Work, such materials and equipment as may be on the Work site and therefore necessary.

## **24. CONSTRUCTION SCHEDULE AND PERIODIC ESTIMATES**

- A. Contractor shall be responsible for Construction Schedule and coordination. Immediately after execution and delivery of Contract and before making first payment, Contractor shall notify all subcontractors to furnish all required information to develop Construction Schedule. Contractor and all subcontractors associated with the Work shall furnish following information from each Division of Specifications:
1. List of construction activities;
  2. Start, finish and time required for completion of each activity;
  3. Sequential relationships between activities;
  4. Identify all long lead-time items, key events, meetings or activities such as required submittals, fabrication and delivery, procurement of materials, installation and testing;
  5. Weekly definition of extent of work and areas of activity for each trade or Subcontract; and
  6. Other information as determined by Public Works Project Engineer.

- B. In addition to above requested items, Contractor shall request delivery dates for all County-furnished equipment, materials or labor. This shall include any work handled by Department under separate contracts such as asbestos abatement, air and water balancing, etc. Indicate on Construction Schedule these associated delivery and installation dates.
- C. Progress Reporting:
1. Contractor shall update and publish Construction Schedule on monthly basis. Revisions to Schedule shall be by Contractor and made in same detail as original Schedule and accompanied by explanation of reasons for revision; and shall be subject to approval by Department.
  2. Failure of Contractor to keep Schedule in updated format shall result in County hiring firm specializing in construction schedule development and deducting those costs associated with updating process from payments due Contractor.
  3. Contractor shall submit show actual percentage of each activity completed, estimated future progress, and anticipated completion time.
- D. Responsibility for timely completion requires:
1. Contractor and subcontractors understand that performance of each is interdependent upon performance of others.
  2. Whenever it becomes apparent from current schedule, that phasing or progress completion dates will not be met, Contractor must take some or all following actions at no additional cost to County:
    - a) Increase construction manpower in such quantities and crafts as will eliminate backlog of work.
    - b) Increase number of working hours per shift, shifts per working day, working days per week, amount of construction equipment, or any combination of foregoing to eliminate backlog of work.
    - c) Reschedule work (yet remain in conformance with Drawings and Specifications).
  3. Prior to proceeding with any of above actions, Contractor shall notify Public Works Project Engineer.
- E. Maintain current Construction Schedule at all times. Revise Construction Schedule in same detail as original and accompany with explanation of reasons for revision. Schedule shall be subject to approval by Architect / Engineer and Public Works Project Engineer.

## **25. PAYMENTS TO CONTRACTOR**

- A. Contractor shall provide:
1. Detailed estimate reporting Architect/Engineer's estimate of percentage of work completed in terms of clay excavated and deposited in Stockpile A and clay excavated and deposited in Stockpile B
- Submit these estimates for approval to Public Works Project Engineer. Costs employed in making up any of these schedules are for determining basis of partial payments and not considered as fixing basis for additions to or deductions from Contract price.
- B. County will make partial payments to Contractor for value, proportionate to amount of Contract, of all labor and material incorporated in the Work during preceding calendar month upon receipt of Application and Certificate for Payment form from Architect / Engineer and approval of Department.

- C. Contractor shall submit for approval first to Architect / Engineer, and then to Public Works Project Engineer all Application and Certificate for Payment forms. If requested, Application and Certificate for Payment shall be supported by such additional evidence as may be required, showing Contractor's right to payment claimed.
- D. Application and Certificate for Payment for preparatory work and materials delivered and suitably stored at site to be incorporated into the Work at some future period, will be given due consideration. Requesting payment for materials stored off site, may be rejected, however, if deemed essential for reasons of job progress, protection, or other sufficient cause, requests will be considered, conditional upon submission by Contractor of bills of sale, photographs and such other procedures as will adequately protect County's interest such as storage in bonded warehouse with adequate coverage. If there is any error in payment, Contractor is obligated to notify Department immediately, but no longer than ten (10) days from receipt of payment.
- E. Payments by County will be due within forty-five (45) days after receipt by Department of Application and Certificate for Payment.
- F. County will retain five percent (5%) of each Application and Certificate for Payment until final completion and acceptance of all the Work covered by Contract. However, anytime after fifty percent (50%) of the Work has been furnished and installed at site, County will make remaining payments in full if Architect / Engineer and Public Works Project Engineer find that progress of the Work corresponds with Construction Schedule. If Architect / Engineer and Public Works Project Engineer find that progress of the Work does not correspond with Construction Schedule, County may retain up to ten percent (10%) of each Application and Certificate for Payment for the Work completed.
- G. All material and work covered by partial payments made shall become sole property of County, but this provision shall not be construed as relieving Contractor from sole responsibility for care and protection of materials and work upon which payments have been made, or restoration of any damaged work, or as waiver of right of County to require fulfillment of all of terms of Contract.
- H. County will make final payment within sixty (60) days after final completion of the Work, and will constitute acceptance thereof. Submit Equal Benefits Compliance Payment Certification with final pay request. Payment may be denied if Certification is not included.
- I. County may make payment in full, including retained percentages and less authorized deductions, upon completion and acceptance of each Division where price is stated separately in Contract.
- J. Every contractor engaged in performance of any contract for Department of Public Works, Highway & Transportation shall submit to this Department, as requested and with final application for payment for work under said contract, affidavit(s) as required to prove that all debts and claims against this Work are paid in full or otherwise satisfied, and give final evidence of release of all liens against the Work and County. If Wisconsin Prevailing Wage Rate Determination is required for this Work, use "Prime Contractor Affidavit of Compliance With Prevailing Wage Rate Determination" and "Agent or Subcontractor Affidavit of Compliance With Prevailing Wage Rate Determination" (if applicable). If Wisconsin Prevailing Wage Rate Determination is not required for this Work, use "Dane County, Wisconsin\_Contractor Wage Affidavit". Forms of such affidavits are included in Supplementary Conditions.



## **26. WITHHOLDING OF PAYMENTS**

- A. County, after having served written notice on said Contractor, may either pay directly any unpaid bills of which Department has written notice, or withhold from Contractor's unpaid compensation sum of money deemed reasonably sufficient to pay any and all such lawful claims until satisfactory evidence is furnished that all liabilities have been fully discharged; whereupon, payment to Contractor shall be resumed in accordance with terms of this Contract, but in no event shall these provisions be construed to impose any obligations upon County to either Contractor or Contractor's Surety.
- B. In paying any unpaid bills of Contractor, County shall be deemed agent of Contractor, and any payment so made by County, shall be considered as payment made under Contract by County to Contractor and County shall not be liable to Contractor for any such payment made in good faith.
- C. Contractor shall indemnify, hold harmless and defend Dane County, its boards, commissions, agencies, officers, employees and representatives from all claims growing out of lawful demands of subcontractors, laborers, workmen, mechanics, material men, and furnishers of machinery and parts thereof, equipment, power tools, and all supplies, including commissary, incurred in performance of this Contract.
- D. At Department's request, Contractor shall furnish satisfactory evidence that all obligations of nature designated above have been paid, discharged or waived.

## **27. ACCEPTANCE OF FINAL PAYMENT AS RELEASE**

- A. Making of final payment shall constitute waiver of all claims by County except those arising from:
  - 1. Unsettled lien;
  - 2. Faulty or defective work appearing after substantial completion;
  - 3. Failure of the Work to comply with requirements of Construction Documents; or
  - 4. Terms of any special guarantees required by Construction Documents.
- B. Acceptance of final payment shall constitute waiver of all claims by Contractor.

## **28. PAYMENTS BY CONTRACTOR**

- A. Contractor shall pay following not later than fifth (5<sup>th</sup>) day following each payment received from County:
  - 1. All transportation and utility services rendered;
  - 2. All materials, tools, and other expendable equipment that have been delivered at site of the Work to extent of ninety percent (90%) of cost thereof, and balance of cost thereof when said balance is paid to Contractor; and
  - 3. Each subcontractor, respective amount allowed Contractor because of work performed by subcontractor to extent of subcontractor's interest therein.

## **29. CONTRACT SECURITY**

- A. Contractor shall furnish Performance and Payment Bonds in amount at least equal to one hundred percent (100%) of Contract price as security for faithful performance of this Contract and payment of all persons performing labor on project under this Contract and furnishing materials in connection with this Contract.
- B. Sample Performance and Payment Bonds that Contractor will be required to execute is bound into these Construction Documents. Before construction Contract is consummated, completed Performance and Payment Bonds must be approved by Department.

### **30. ASSIGNMENTS**

- A. Contractor shall not assign whole or any part of this Contract or any moneys due or to become due hereunder without written consent of Department. In case Contractor assigns all or any part of any moneys due or to become due under this Contract, instrument of assignment shall contain clause substantially to effect that it is agreed that right of assignee in and to any moneys due or to become due to Contractor shall be subject to prior claims of all persons, firms and corporations for services rendered or materials supplied for performance of the Work called for in this Contract.

### **31. MUTUAL RESPONSIBILITY OF CONTRACTORS**

- A. If, through acts of neglect on part of Contractor or any subcontractor shall suffer loss or damage on the Work, Contractor agrees to settle with such subcontractor by agreement or arbitration if such other subcontractor will so settle. If such subcontractor shall assert any claim against County on account of any damage alleged to have been sustained, Department shall notify Contractor, who shall indemnify, hold harmless and defend Dane County, its boards, commissions, agencies, officers, employees and representatives against any such claim.

### **32. SEPARATE CONTRACTS**

- A. Department may award other contracts for the Work and all Contractors shall fully cooperate with each other and carefully adjust their work to that provided under other contracts as may be directed by Department. No Contractor shall commit or permit any act that will interfere with performance of the Work by any other Contractor.
- B. Contractor shall coordinate the Work with those of other Contractors. Cooperation will be required in arrangement for storage of materials and in detailed execution of the Work. Contractor, including subcontractors, shall keep informed of progress and detail work of others and shall notify Architect / Engineer or Department immediately of lack of progress or defective workmanship on part of others. Failure of Contractor to keep informed of the Work progressing on site and failure to give notice of lack of progress or defective workmanship by others shall be construed as acceptance by Contractor of status of the Work as being satisfactory for proper coordination with Contractor's own work.

### **33. SUBCONTRACTS**

- A. Contractor may use services of specialty subcontractors on those parts of the Work that, under normal contracting practices, are performed by specialty subcontractors.

- B. Contractor shall not award any work to any subcontractor without prior approval of Department. Qualifications of subcontractors shall be same as qualifications of Contractor. Request for subcontractor approval shall be submitted to Department fifteen (15) days before start of subcontractor's work. If subcontractors are changed or added, Contractor shall notify Department in writing.
- C. Contractor shall be as fully responsible to County for acts and omissions of subcontractors, and of persons either directly or indirectly employed by them, as Contractor is for acts and omissions of persons directly employed by Contractor.
- D. Contractor shall cause appropriate provisions to be inserted in all subcontracts relative to the Work to bind subcontractors to Contractor by terms of General Conditions of Contract and other Construction Documents insofar as applicable to work of subcontractors and to give Contractor same power as regards terminating any subcontract that Department may exercise over Contractor under any provision of Construction Documents.
- E. Nothing contained in this Contract shall create any contractual relation between any subcontractor and County.
- F. Contractor shall insert in all subcontracts, Articles 26, 33, 43 and 45, respectively entitled: "Withholding of Payments", "Subcontracts", "Affirmative Action Provision and Minority / Women / Disadvantaged Business Enterprises", and "Minimum Wages", and shall further require all subcontractors to incorporate physically these same Articles in all subcontracts.

#### **34. PUBLIC WORKS PROJECT ENGINEER'S AUTHORITY**

- A. Public Works Project Engineer shall:
  - 1. Administer and ensure compliance with Construction Documents;
  - 2. Provide responsible on-site observations of construction and have authority to request work and to stop work whenever necessary to insure proper enforcement of Construction Documents;
  - 3. Convene and chair project meetings and foreman's coordination meetings when necessary to coordinate resolution of conflicts between Contractors, Architects, Engineers, Consultants, and Department; and
  - 4. Check and inspect material, equipment and installation procedures of all trades for proper workmanship and for compliance with Drawings, Specifications and Shop Drawings, permit no material on project site that is not satisfactory and reject work not in compliance with Construction Documents.

#### **35. ARCHITECT / ENGINEER'S AUTHORITY**

- A. Architect / Engineer is retained by, and is responsible to Department acting for County.
- B. Architect / Engineer shall determine amount, quality, acceptability, and fitness of several kinds of work and materials that are provided under this Contract and shall decide all questions that may arise in relation to said work and construction thereof.
- C. Architect / Engineer shall decide meaning and intent of any portion of Specifications and of any Drawings where they may be found obscure or be in dispute.

- D. Architect / Engineer shall provide responsible observation of construction. Architect / Engineer has authority to stop the Work whenever such stoppage may be necessary to insure proper execution of Construction Documents.
- E. Architect / Engineer shall be interpreter of conditions of Construction Documents and judge of its performance.
- F. Within reasonable time, Architect / Engineer shall make decisions on all matters relating to progress of the Work or interpretation of Construction Documents.
- G. Architect / Engineer's decisions are subject to review by Public Works Project Engineer.

### **36. STATED ALLOWANCES**

- A. Stated allowances enumerated in Instructions to Bidders shall cover net cost of materials or equipment, and all applicable taxes. Contractor's cost of delivery and unloading at site, handling costs on site, labor, installation costs, overhead, profit and any other incidental costs shall be included in Contractor's bid, but not as part of cash allowance.
- B. Department will solicit at least two (2) bids on materials or equipment for which allowance is stated and select on basis of lowest qualified responsible bid. Contractor will then be instructed to purchase "Allowed Materials". If actual price for purchasing "Allowed Materials", including taxes, is more or less than "Cash Allowance", Contract price shall be adjusted accordingly. Adjustment in Contract price shall not contain any cost items excluded from cash allowance.

### **37. ESTIMATES OF QUANTITIES**

- A. Whenever estimated quantities of work to be done and materials to be furnished under this Contract are shown in any of Construction Documents, they are given for use in comparing bids and right is especially reserved to increase or diminish them as they may be deemed reasonably necessary or desirable by Department to complete the Work included in this Contract, and cost for such increase or diminution shall be adjusted in manner provided for in General Conditions of Contract Article 18 entitled "Changes in the Work".

### **38. LANDS AND RIGHTS-OF-WAY**

- A. Prior to start of construction, County shall furnish all land and rights-of-way necessary for carrying out and completion of the Work to be performed under this Contract.

### **39. GENERAL GUARANTEE**

- A. Neither final certificate of payment nor any provision in Construction Documents nor partial or entire occupancy of premises by County shall constitute acceptance of work not done in accordance with Construction Documents or relieve Contractor of liability in respect to any expressed warranties or responsibility for faulty materials or workmanship.
  - 1. In no event shall making of any payment required by Contract constitute or be construed as waiver by County of any breach of covenants of Contract or waiver of any default of Contractor and making of any such payment by County while any such default or breach

shall exist shall in no way impair or prejudice right of County with respect to recovery of damages or other remedy as result of such breach or default.

- B. Contractor shall remedy and make good all defective workmanship and materials and pay for any damage to other work resulting there from, which appear within period of one (1) year from date of substantial completion, providing such defects are not clearly due to abuse or misuse by County. Department will give notice of observed defects with reasonable promptness.
- C. Guarantee on work executed after certified date of substantial completion will begin on date when such work is inspected and approved by Architect / Engineer and Public Works Project Engineer.
- D. Where guarantees or warranties are required in sections of Specifications for periods in excess of one (1) year, such longer terms shall apply; however, Contractor's Performance and Payment Bonds shall not apply to any guarantee or warranty period in excess of one (1) year.

#### **40. CONFLICTING CONDITIONS**

- A. Any provision in any of Construction Documents which may be in conflict or inconsistent with any Articles in these General Conditions of Contract or Supplementary Conditions shall be void to extent of such conflict or inconsistency.
- B. In case of ambiguity or conflict between Drawings and Specifications, Specifications shall govern.
- C. Printed dimensions shall be followed in preference to measurements by scale. Large-scale drawings take precedence over small-scale drawings. Dimensions on Drawings and details are subject to field measurements of adjacent work.

#### **41. NOTICE AND SERVICE THEREOF**

- A. Any notice to Contractor from Department relative to any part of this Contract shall be in writing and considered delivered and service thereof completed, when said notice is posted, by certified or registered mail, to Contractor at Contractor's last given address, or delivered in person to said Contractor, or Contractor's authorized representative on the Work.

#### **42. PROTECTION OF LIVES AND HEALTH**

- A. In order to protect lives and health of Contractor's employees under Contract, Contractor shall comply with all pertinent provisions of Wisconsin Administrative Code, Rules of Department of Commerce, relating to Safety and Health.
- B. Contractor alone shall be responsible for safety, efficiency and adequacy of Contractor's tools, equipment and methods, and for any damage that may result from their failure or their improper construction, maintenance or operation.

#### **43. AFFIRMATIVE ACTION PROVISION AND MINORITY / WOMEN / DISADVANTAGED BUSINESS ENTERPRISES**

A. Affirmative Action Provisions.

1. During term of their Contract, Contractor agrees not to discriminate on basis of race, religion, color, sex, handicap, age, sexual preference, marital status, physical appearance, or national origin against any person, whether recipient of services (actual or potential), employee, or applicant for employment. Such equal opportunity shall include but not be limited to following: employment, upgrading, demotion, transfer, recruitment, advertising, layoff, termination, training, rates of pay, and any other form of compensation or level of service(s). Contractor agrees to post in conspicuous places, these affirmative action standards so as to be visible to all employees, service recipients and applicants for this paragraph. Listing of prohibited bases for discrimination shall not be construed to amend in any fashion state or federal law setting forth additional bases and exceptions shall be permitted only to extent allowable in state or federal law.
2. Contractor is subject to this Article only if Contractor has ten (10) or more employees and receives \$10,000.00 or more in annual aggregate contracts with County. Contractor shall file and Affirmative Action Plan with Dane County Contract Compliance Officer in accord with Chapter 19 of Dane County Code of Ordinances. Such plan must be filed within fifteen (15) days of effective date of this Contract and failure to do so by said date shall constitute ground for immediate termination of Contract by County. Contractor shall also, during term of this Contract, provide copies of all announcements of employment opportunities to County's Contract Compliance Office, and shall report annually number of persons, by race, sex and handicap status, who apply for employment and, similarly classified, number hired and number rejected.
3. Contact Dane County Contract Compliance Officer at Dane County Contract Compliance Office, 210 Martin Luther King, Jr. Blvd., Room 421, Madison, WI 53703, 608/266-4114.
4. In all solicitations for employment placed on Contractor's behalf during term of this Contract, Contractor shall include statement to effect Contractor is "Equal Opportunity Employer". Contractor agrees to furnish all information and reports required by County's Contract Compliance Officer as same relate to affirmative action and nondiscrimination, which may include any books, records, or accounts deemed appropriate to determine compliance with Chapter 19, Dane County Code of Ordinances, and provision of this Contract.

B. Minority / Women / Disadvantaged / Emerging Small Business Enterprises.

1. Chapter 19.508 of Dane County Code of Ordinances is official policy of Dane County regarding utilization of, to fullest extent of, Minority Business Enterprises (MBEs), Women Business Enterprises (WBEs) Disadvantage Business Enterprises (DBEs) and Emerging Small Business Enterprises (ESBEs).
2. Contractor may utilize MBEs / WBEs / DBEs / ESBEs as subcontractors or suppliers. List of subcontractors will be required of low bidder as stated in this Contract. List shall indicate which are MBEs / WBEs / DBEs / ESBEs and percentage of subcontract awarded, shown as percentage of total dollar amount of bid.

**44. COMPLIANCE WITH FAIR LABOR STANDARDS**

- A. During term of this Contract, Contractor shall report to County Contract Compliance Officer, within ten (10) days, any allegations to, or findings by National Labor Relations Board (NLRB) or Wisconsin Employment Relations Commission (WERC) that Contractor has violated statute or regulation regarding labor standards or relations. If investigation by Contract Compliance Officer results in final determination that matter adversely affects

Contractor's responsibilities under this Contract, and which recommends termination, suspension or cancellation of this Contract, County may take such action.

- B. Contractor may appeal any adverse finding by Contract Compliance Officer as set forth in Dane County Ordinance 25.015(11)(c) through (e).
- C. Contractor shall post this statement in prominent place visible to employees: "As condition of receiving and maintaining contract with Dane County, this employer shall comply with federal, state and all other applicable laws prohibiting retaliation or union organizing."

#### **45. DOMESTIC PARTNERSHIP BENEFITS**

- A. Contractor agrees to provide same economic benefits to all of its employees with domestic partners as it does to employees with spouses, or cash equivalent if such benefit cannot reasonably be provided. Contractor agrees to make available for County inspection Contractor's payroll records relating to employees providing services on or under this Contract or subcontract. If any payroll records of Contractor contain any false, misleading or fraudulent information, or if Contractor fails to comply with provisions of Chapter 25.016, Dane County Ordinances, contract compliance officer may withhold payments on Contract; terminate, cancel or suspend Contract in whole or in part; or, after due process hearing, deny Contractor right to participate in bidding on future County contracts for period of one year after first violation is found and for period of three years after second or subsequent violation is found.

#### **46. USE AND OCCUPANCY PRIOR TO ACCEPTANCE**

- A. Contractor agrees to use and occupancy of portion or unit of the Work before formal acceptance by Department, provided Department:
  - 1. Secures written consent of Contractor; except when in opinion of Public Works Project Engineer, Contractor is chargeable with unwarranted delay in final cleanup of punch list items or other Contract requirements.
  - 2. Secures endorsement from insurance carrier and consent of Surety permitting occupancy of building or use of the Work during remaining period of construction, or, secures consent of Surety.
  - 3. Assumes all costs and maintenance of heat, electricity and water.
  - 4. Accepts all work completed within that portion or unit of the Work to be occupied, at time of occupancy.

#### **47. MINIMUM WAGES**

- A. Contractor shall post, at appropriate conspicuous point on site of project, schedule showing all determined minimum wage rates for various classes of laborers and mechanics to be engaged in the Work under this Contract and all deductions, if any, required by law to be made from unpaid wages actually earned by laborers and mechanics so engaged.
- B. Supplementary Conditions section in Construction Documents lists wage determinations required by State Law.
- C. If, after award of Contract, it becomes necessary to employ any person in trade or occupation not classified in wage determinations, such person shall be paid at not less than such rate as shall be determined by Wisconsin Department of Workforce Development. Such approved

minimum rate shall be retroactive to time of initial employment of such person in such trade or occupation. Contractor shall notify Department of Contractor's intention to employ persons in trades or occupations not so classified in sufficient time for Department to obtain approved rates for such trades or occupations.

- D. Specified wage rates are minimum rates only, and Department will not consider any claims for additional compensation made by Contractor because of payment by Contractor of any wage rate in excess of applicable rate contained in this Contract. Contractor shall adjust any disputes in regard to payment of wages in excess of those specified in this Contract.
- E. Submit required affidavit(s) to Department of Public Works, Highway & Transportation, as requested and with final application for payment for work under said contract. Affidavit(s) shall clearly indicate name, trade or occupation, and paid wages of every laborer, workman or mechanic employed by Contractor and all subcontractors during billing period including accurate record of number of hours worked by each employee and actual wages paid as stipulated in Wisconsin Statute 66.0903. If Wisconsin Prevailing Wage Rate Determination is required for this Work, use "Prime Contractor Affidavit of Compliance With Prevailing Wage Rate Determination" and "Agent or Subcontractor Affidavit of Compliance With Prevailing Wage Rate Determination" (if applicable). If Wisconsin Prevailing Wage Rate Determination is not required for this Work, use "Dane County, Wisconsin Contractor Wage Affidavit". Forms of such affidavits are included in Supplementary Conditions.

#### **48. CLAIMS**

- A. No claim may be made until Department's Associate Public Works Director has reviewed Architect / Engineer's decision as provided for in Article 35 of General Conditions of Contract. If any claim remains unresolved after such review by Department's Associate Public Works Director, claim may be filed under Wisconsin Statute 893.80. Work shall progress during period of any dispute or claim. Unless specifically agreed between parties, venue will be in Dane County, Wisconsin.

#### **49. ANTITRUST AGREEMENT**

- A. Contractor and County recognize that in actual economic practice, overcharges resulting from antitrust violations are in fact usually borne by County. Therefore, Contractor hereby assigns to County any and all claims for such overcharges as to goods and materials purchased in connection with this Contract, except as to overcharges which result from antitrust violations commencing after price is established under this Contract and any change order thereto.

#### **50. INSURANCE**

- A. Contractor Carried Insurance:
  - 1. Contractor shall not commence work under this Contract until Contractor has obtained all insurance required under this Article and has provided evidence of such insurance to Risk Manager, 425 City-County Building, 210 Martin Luther King Jr. Blvd., Madison, WI 53703. Contractor shall not allow any subcontractor to commence work until insurance required of subcontractor has been so obtained and approved. Company providing insurance must be licensed to do business in Wisconsin.
  - 2. Worker's Compensation Insurance:



- a) Contractor shall procure and shall maintain during life of this Contract, Worker's Compensation Insurance as required by statute for all of Contractor's employees engaged in work at site of project under this Contract and, in case of any such work sublet, Contractor shall require subcontractor similarly to provide Worker's Compensation Insurance for all of latter's employees to be engaged in such work unless such employees are covered by protection afforded by Contractor's Worker's Compensation Insurance.
  - b) If any claim of employees engaged in hazardous work on project under this Contract is not protected under Worker's Compensation Statute, Contractor shall provide and shall cause each subcontractor to provide adequate Employer's Liability Insurance for protection of such of Contractor's employees as are not otherwise protected.
3. Contractor's Public Liability and Property Damage Insurance:
- a) Contractor shall procure and maintain during life of this Contract, Contractor's Public Liability Insurance and Contractor's Property Damage Insurance in amount not less than \$1,000,000 bodily injury, including accidental death, to any one person, and subject to same limit for each person, in amount not less than \$1,000,000 on account of one accident, and Contractor's Property Damage Insurance in amount not less than \$1,000,000 or combined single limit of at least \$1,000,000 with excess coverage over and above general liability in amount not less than \$5,000,000. Contractor shall add "Dane County" and "Madison Area Technical College" as additional insured for each project.
  - b) Contractor's Public Liability and Property Damage Insurance shall include Products, Completed Operation, and Contractual Liability under Insurance Contract. "Contractor shall in all instances save, defend, indemnify and hold harmless County and Architect / Engineer against all claims, demands, liabilities, damages or any other costs which may accrue in prosecution of the Work and that Contractor will save, defend, indemnify and hold harmless County and Architect / Engineer from all damages caused by or as result of Contractor's operations" and each shall be listed as additional insured on Contractor's and sub-contractors' insurance policies.
  - c) Obligations of Contractor under Article 48.A.2)b) shall not extend to liability of Architect / Engineer, agents or employees thereof, arising out of:
    - 1) Preparation or approval of maps, drawings, opinions, reports, surveys, change orders, designs or specifications; or
    - 2) giving of or failure to give directions or instructions by Architect / Engineer, agents or employees thereof provided such giving or failure to give is primary cause of injury or damage.
  - d) Contractor shall procure and shall maintain during life of this Contract, Comprehensive Automobile Liability Insurance covering owned, non-owned and hired automobiles for limits of not less than \$1,000,000 each accident single limit, bodily injury and property damage combined with excess coverage over and above general liability in amount not less than \$5,000,000.
  - e) Contractor shall either:
    - 1) Require each subcontractor to procure and to maintain during life of subcontract, subcontractor's Public Liability Property Damage Insurance, and Comprehensive Automobile Liability Insurance of type and in same amount specified in preceding paragraphs; or
    - 2) Insure activities of subcontractors in Contractor's own policy.
4. Scope of Insurance and Special Hazards: Insurance required under Article 48.A.2 hereof shall provide adequate protection for Contractor and subcontractors, respectively, against damage claims which may arise from operations under this Contract, whether such operation be by insured or by anyone directly or indirectly employed by insured and also

against any of special hazards which may be encountered in performance of this Contract as enumerated in Supplementary Conditions.

5. Proof of Carriage of Insurance: Contractor shall furnish Risk Manager with certificates showing type, amount, class of operations covered, effective dates, dates of expiration of policies and "Dane County" and "Madison Area Technical College" listed as additional insured. Such certificates shall also contain (substantially) following statement:  
"Insurance covered by this certificate will not be canceled or materially altered, except after ten (10) days written notice has been received by Risk Manager."

**B. Builder's Risk:**

1. County shall provide Builder's Risk policy. Terms of this policy will be made available by County's Risk Manager, upon Contractor's request. By executing this Contract, Contractor warrants it is familiar with terms of said policy.

**C. Indemnification / Hold Harmless:**

1. Contractor shall indemnify, hold harmless and defend Dane County, its boards, commissions, agencies, officers, employees and representatives from and against all claims, damages, losses and expenses including attorneys' fees arising out of or resulting from performance of the Work, provided that any such claim, damage, loss or expense is attributable to bodily injury, sickness, disease or death, or to injury to or destruction of tangible property (other than the Work itself) including loss of use resulting therefrom, and is caused in whole or in part by any act or omission of Contractor, any subcontractor, anyone directly or indirectly employed by any of them or anyone for whose acts any of them may be liable, regardless of whether or not it is caused in part by part indemnified hereunder.
2. In any and all claims against Dane County, its boards, commissions, agencies, officers, employees and representatives or by any employee of Contractor, any subcontractor, anyone directly or indirectly employed by any of them or anyone for whose acts any of them may be liable, indemnification obligation under this Contract shall not be limited in any way by any limitation on amount or type of damages, compensation or benefits payable by or for Contractor or any subcontractor under worker's compensation acts, disability benefits or other employee benefit acts.
3. Obligations of Contractor under this Contract shall not extend to liability of Architect / Engineer, its agents or employees arising out of:
  - a) Preparation or approval of maps, drawings, opinion, reports, surveys, change orders, designs or specifications; or
  - b) Giving of or failure to give directions or instruction by Architect / Engineer, its agents or employees provided such giving or failure to give is primary cause of injury or damage.
4. Dane County shall not be liable to Contractor for damages or delays resulting from work by third parties or by injunctions or other restraining orders obtained by third parties.

**51. WISCONSIN LAW CONTROLLING**

- A. It is expressly understood and agreed to by parties hereto that in event of any disagreement or controversy between parties, Wisconsin law shall be controlling.

## SUPPLEMENTARY CONDITIONS

### 1. APPLICATION & CERTIFICATE FOR PAYMENT

- A. Every contractor engaged in performance of any contract for Department of Public Works, Highway & Transportation shall submit partial and final Application & Certificate for Payment for work under said contract. Form shall provide similar information as shown on AIA G702™ and G703™ forms (samples shown below). Forms shall be submitted to Public Works Project Engineer for approval.

**AIA Document G702™ - 1992**

**Application and Certificate for Payment**

TO OWNER:	PROJECT:	APPLICATION NO.:	DISTRIBUTION TO:
FROM CONTRACTOR:	VIA ARCHITECT:	PERIOD TO:	OWNER <input type="checkbox"/>
		CONTRACT FOR:	ARCHITECT <input type="checkbox"/>
		CONTRACT DATE:	CONTRACTOR <input type="checkbox"/>
		PROJECT NOS.:	FIELD <input type="checkbox"/>
			OTHER <input type="checkbox"/>

**CONTRACTOR'S APPLICATION FOR PAYMENT**

Application is made for payment, as shown below, in accordance with the Contract Documents, AIA Document G702™, as amended.

1. ORIGINAL CONTRACT SUM: \$ \_\_\_\_\_

2. Net change by Change Orders: \$ \_\_\_\_\_

3. CONTRACT SUM TO DATE (Line 1 + 2): \$ \_\_\_\_\_

4. TOTAL COMPLETED & STORED TO DATE (Line 3 - 5): \$ \_\_\_\_\_

5. RETAINAGE

    a. % of Contract Sum: \_\_\_\_\_

    b. % of Stored Amount (Column F in G702™): \_\_\_\_\_

    c. Total Retainage: \$ \_\_\_\_\_

6. TOTAL EARNED LESS RETAINAGE (Line 4 Less Line 5 Total): \$ \_\_\_\_\_

7. LESS PREVIOUS CERTIFICATE FOR PAYMENT (Line 6 from prior Certificate): \$ \_\_\_\_\_

8. CURRENT PAYMENT DUE (Line 6 Less Line 7): \$ \_\_\_\_\_

9. BALANCE TO FINAL, INCLUDING RETAINAGE (Line 7 Less Line 8): \$ \_\_\_\_\_

The undersigned Contractor certifies that in the preparation of this Application, information and fact are true and correct, and that the amount of payment requested is in accordance with the Contract Documents, and that all amounts have been paid for the Contractor for Work for which payment is requested. The Contractor is not aware of any other amounts due to the Owner, and that no other payment is due to the Owner.

CONTRACTOR: \_\_\_\_\_  
 Title: \_\_\_\_\_  
 Date: \_\_\_\_\_  
 Name: \_\_\_\_\_  
 My Commission expires: \_\_\_\_\_

**ARCHITECT'S CERTIFICATE FOR PAYMENT**

In accordance with the Contract Documents, based on my observations and the last completed Application, the Architect certifies to the Owner that to the best of the Architect's knowledge, information and belief the Work has progressed as indicated; the quality of the Work is in accordance with the Contract Documents; and the Contractor is entitled to payment of the AMOUNT CERTIFIED.

AMOUNT CERTIFIED: \$ \_\_\_\_\_

(Amount certification of amounts certified differs from the amount applied. Amounts applied on this Application and on the Commission Sheet that are changed in relation with this amount certified.)

ARCHITECT: \_\_\_\_\_  
 Title: \_\_\_\_\_  
 Date: \_\_\_\_\_

This Certificate is not negotiable. The AMOUNT CERTIFIED is payable only to the Contractor named herein. Issuance, payment and acceptance of payment are without prejudice to any rights of the Architect or Contractor under the Contract.

CHANGE ORDER SUMMARY	ADDITIONS	DEDUCTIONS
Total Change approved on previous months by Owner	\$	\$
Total approved this Month	\$	\$
<b>TOTALS</b>	<b>\$</b>	<b>\$</b>
NET INCREASE by Change Order	\$	\$

All Document G702™ - 1992 Copyright © 1992, 1993, 1994, 1995, 1996 and 1997 by The American Institute of Architects. All rights reserved. WARNING: May Not Be Copied or Reproduced in whole or in part without the prior written permission of the American Institute of Architects. This document is a copyrighted work of the American Institute of Architects and its use is restricted to the specific project and contract documents. It may be reproduced for personal or internal use only. For more information, contact the American Institute of Architects, 1735 M Street, N.W., Washington, D.C. 20036. (202) 638-1000. www.aia.org

**Continuation Sheet**

AIA Document G703, APPLICATION AND CERTIFICATION FOR PAYMENT, containing Contractor's specific certification is attached.  
 In full payment of the amount set forth in the account, I declare:  
 I am a Licensed Civil Contractor whose suitable license for this State has not expired.

APPLICATION NO:  
 APPLICATION DATE:  
 PERIOD TO:  
 ARCHITECT'S PROJECT NO.:

A ITEM NO.	B DESCRIPTION OF WORK	C SCHEDULED VALUE	D WORK COMPLETED		F MATERIALS PRESENTLY STORED ON-SITE	G TOTAL COMPLETED AND STORED TO DATE (G = C - F)	H BALANCE TO PAY (H = G - F)	I RETAINAGE ON WORK BASE
			E FROM PROGRESS APPLICATION (D + E)	F THIS PERIOD				

**CAUTION:** You should sign an original AIA Contract Document, in which this text appears in RED. An original assures that changes will not be introduced.  
 AIA Document G703™ – 1992 Copyright © 1992, 1993, 1994, 1995, 1996, 1997, 1998 and 1999 by The American Institute of Architects. All rights reserved. This AIA Document is prepared by the U.S. Subcontract Law and International Trade Commission. Reproduction or distribution of this AIA Document, or any portion of it, may result in serious civil and criminal penalties, and will be prosecuted to the maximum extent possible under the law. Permission is granted to reproduce for 100 copies of this document when compiled. To report copyright violations of AIA Contract Documents, email: TheAmericanInstituteofArchitects@aia.org.

**2. PREVAILING WAGE RATE DETERMINATION**

- A. These supplements shall modify, delete, and / or add to General Conditions of Contract. Where any article, paragraph, or subparagraph in General Conditions of Contract is supplemented by one of these paragraphs, provisions of such article, paragraph, or subparagraph shall remain in effect and supplementary provisions shall be considered as added thereto. Where any article, paragraph, or subparagraph in General Conditions of Contract is amended, voided, or superseded by any of these paragraphs, provisions of such article, paragraph, or subparagraph not so amended, voided, or superseded shall remain in effect.
  - 1. General Conditions of Contract Article 47, “Minimum Wages”, paragraph B. Following Prevailing Wage Rate Determination No. 201400146 is added to General Conditions of Contract.
  
- B. These State of Wisconsin forms, hereinafter set forth in this section, shall be filled out and submitted to Department of Public Works, Highway & Transportation:
  - 1. Disclosure of Ownership (ERD-7777)
  - 2. Prime Contractor Affidavit of Compliance With Prevailing Wage Rate Determination (ERD-5724)
  - 3. List of Agents and Subcontractors (Page 2 - ERD-5724)
  - 4. Agent or Subcontractor Affidavit of Compliance With Prevailing Wage Rate Determination (ERD-10584)
  - 5. List of Agents and Subcontractors (Page 2 - ERD-10584)
  - 6. Request To Employ Subjourneyperson (ERD-10880)

State of Wisconsin Department of Workforce Development Equal Rights Division	<b>DEPARTMENTAL ORDER</b>
<b>ISSUE DATE:</b> 1/22/2014	
<b>PROJECT:</b>	
CLAY EXCAVATION AND TRUCKING WESTPORT TOWN, DANE COUNTY, WI Determination No. 201400146 [Owner Project No. 314002]	
<b>PROJECT OWNER:</b>	<b>REQUESTER:</b>
JOHN WELCH, RECYCLING MANAGER / PROJECT MANAGER DANE COUNTY 1919 ALLIANT ENERGY CTR WAY MADISON, WI 53713	JOHN WELCH, RECYCLING MANAGER / PROJECT MANAGER DANE COUNTY 1919 ALLIANT ENERGY CTR WAY MADISON, WI 53713
<b>ADDITIONAL CONTACT:</b>	<b>NOTE:</b> The Requester must provide a copy of this Project Determination and enclosures to the Project Owner and Additional Contact.
<p>The department received an application for prevailing wage rate determination for the above-captioned project. The department conducted a survey to determine the prevailing wage rate for the trade(s) or occupation(s) needed to complete the project. The survey's findings appear in the attached project determination.</p> <p>If you believe that the wage rate for any trade or occupation does not accurately reflect the prevailing wage rate in the city, village or town where the project is located, you may ask the department to conduct an administrative review of such wage rate. You must submit this request in writing within 30 days from the date indicated above. Additionally, your request must include wage rate information from at least three similar projects in the city, village or town where the proposed project is located and on which some work has been performed by the contested trade(s) during the current survey period and was previously considered by the department in issuing the attached determination. See DWD 290.10 of the Wisconsin Administrative Code and either s. 66.0903(3)(br), Stats., or s. 103.49(3)(c), Stats., for a complete explanation of the administrative review process.</p> <p>Enclosures</p>	
<p>It is hereby ordered that the prevailing wage rates set forth in the attached project determination shall only be applicable to the above referenced project. This order is a <b>FINAL ORDER</b> of the department unless a timely request for an administrative review is filed with the department.</p> <p>ISSUED BY:</p> <p style="text-align: center;">         Equal Rights Division          Labor Standards Bureau          Construction Wage Standards Section          P.O. Box 8928, Madison, WI 53708-8928          (608)266-6861       </p> <p style="text-align: center;">         Web Site: <a href="http://dwd.wisconsin.gov/er/">http://dwd.wisconsin.gov/er/</a> </p>	

**PREVAILING WAGE RATE DETERMINATION**

Issued by the State of Wisconsin  
Department of Workforce Development  
Pursuant to s. 66.0903, Wis. Stats.  
Issued On: 1/22/2014

**DETERMINATION NUMBER:** 201400146

**EXPIRATION DATE:** Prime Contracts MUST Be Awarded or Negotiated On Or Before 12/31/2014. If NOT, You MUST Reapply.

**PROJECT NAME:** CLAY EXCAVATION AND TRUCKING  
PROJECT NO: 314002

**PROJECT LOCATION:** WESTPORT TOWN, DANE COUNTY, WI

**CONTRACTING AGENCY:** DANE COUNTY

<b>CLASSIFICATION:</b>	Contractors are responsible for correctly classifying their workers. Either call the Department of Workforce Development (DWD) with trade or classification questions or consult DWD's Dictionary of Occupational Classifications & Work Descriptions on the DWD website at: <a href="http://dwd.wisconsin.gov/er/prevailing_wage_rate/Dictionary/dictionary_main.htm">dwd.wisconsin.gov/er/prevailing_wage_rate/Dictionary/dictionary_main.htm</a> .
<b>OVERTIME:</b>	<p>Time and one-half must be paid for all hours worked:</p> <ul style="list-style-type: none"><li>- over 10 hours per day on prevailing wage projects</li><li>- over 40 hours per calendar week</li><li>- Saturday and Sunday</li><li>- on all of the following holidays: January 1; the last Monday in May; July 4; the 1st Monday in September; the 4th Thursday in November; December 25;</li><li>- The day before if January 1, July 4 or December 25 falls on a Saturday;</li><li>- The day following if January 1, July 4 or December 25 falls on a Sunday.</li></ul> <p>Apply the time and one-half overtime calculation to whichever is higher between the Hourly Basic Rate listed on this project determination or the employee's regular hourly rate of pay. Add any applicable Premium or DOT Premium to the Hourly Basic Rate before calculating overtime.</p> <p>A DOT Premium (discussed below) may supersede this time and one-half requirement.</p>
<b>FUTURE INCREASE:</b>	When a specific trade or occupation requires a future increase, you MUST add the full hourly increase to the "TOTAL" on the effective date(s) indicated for the specific trade or occupation.
<b>PREMIUM PAY:</b>	If indicated for a specific trade or occupation, the full amount of such pay MUST be added to the "HOURLY BASIC RATE OF PAY" indicated for such trade or occupation, whenever such pay is applicable.
<b>DOT PREMIUM:</b>	This premium only applies to highway and bridge projects owned by the Wisconsin Department of Transportation and to the project type heading "Airport Pavement or State Highway Construction." DO NOT apply the premium calculation under any other project type on this determination.
<b>APPRENTICES:</b>	Pay apprentices a percentage of the applicable journey person's hourly basic rate of pay and hourly fringe benefit contributions specified in this determination. Obtain the appropriate percentage from each apprentice's contract or indenture.
<b>SUBJOURNEY:</b>	Subjourney wage rates may be available for some of the trades or occupations indicated below with the exception of laborers, truck drivers and heavy equipment operators. Any employer interested in using a subjourney classification on this project MUST complete Form ERD-10880 and request the applicable wage rate from the Department of Workforce Development PRIOR to using the subjourney worker on this project.

This document **MUST BE POSTED** by the **CONTRACTING AGENCY** in at least one conspicuous and easily accessible place **on the site of the project**. A local governmental unit may post this document at the place normally used to post public notices if there is no common site on the project. This document **MUST** remain posted during the entire time any worker is employed on the project and **MUST** be physically incorporated into the specifications and all contracts and subcontracts. If you have any questions, please write to the Equal Rights Division, Labor Standards Bureau, P.O. Box 8928, Madison, Wisconsin 53708 or call (608) 266-6861.

**The following statutory provisions apply to local governmental unit projects of public works and are set forth below pursuant to the requirements of s. 66.0903(8), Stats.**

**s. 66.0903 (1) (f) & s. 103.49 (1) (c) "PREVAILING HOURS OF LABOR"** for any trade or occupation in any area means 10 hours per day and 40 hours per week and may not include any hours worked on a Saturday or Sunday or on any of the following holidays:

1. January 1.
2. The last Monday in May.
3. July 4.
4. The first Monday in September.
5. The 4th Thursday in November.
6. December 25.
7. The day before if January 1, July 4 or December 25 falls on a Saturday.
8. The day following if January 1, July 4 or December 25 falls on a Sunday.

**s. 66.0903 (10) RECORDS; INSPECTION; ENFORCEMENT.**

(a) Each contractor, subcontractor, or contractor's or subcontractor's agent performing work on a project of public works that is subject to this section shall keep full and accurate records clearly indicating the name and trade or occupation of every person performing the work described in sub. (4) and an accurate record of the number of hours worked by each of those persons and the actual wages paid for the hours worked.

**s. 66.0903 (11) LIABILITY AND PENALTIES.**

(a) 1. Any contractor, subcontractor, or contractor's or subcontractor's agent who fails to pay the prevailing wage rate determined by the department under sub. (3) or who pays less than 1.5 times the hourly basic rate of pay for all hours worked in excess of the prevailing hours of labor is liable to any affected employee in the amount of his or her unpaid wages or his or her unpaid overtime compensation and in an additional amount as liquidated damages as provided under subd. 2., 3., whichever is applicable.

2. If the department determines upon inspection under sub. (10) (b) or (c) that a contractor, subcontractor, or contractor's or subcontractor's agent has failed to pay the prevailing wage rate determined by the department under sub. (3) or has paid less than 1.5 times the hourly basic rate of pay for all hours worked in excess of the prevailing hours of labor, the department shall order the contractor to pay to any affected employee the amount of his or her unpaid wages or his or her unpaid overtime compensation and an additional amount equal to 100 percent of the amount of those unpaid wages or that unpaid overtime compensation as liquidated damages within a period specified by the department in the order.

3. In addition to or in lieu of recovering the liability specified in subd. 1. as provided in subd. 2., any employee for and in behalf of that employee and other employees similarly situated may commence an action to recover that liability in any court of competent jurisdiction. If the court finds that a contractor, subcontractor, or contractor's or subcontractor's agent has failed to pay the prevailing wage rate determined by the department under sub. (3) or has paid less than 1.5 times the hourly basic rate of pay for all hours worked in excess of the prevailing hours of labor, the court shall order the contractor, subcontractor, or agent to pay to any affected employee the amount of his or her unpaid wages or his or her unpaid overtime compensation and an additional amount equal to 100 percent of the amount of those unpaid wages or that unpaid overtime compensation as liquidated damages.

5. No employee may be a party plaintiff to an action under subd. 3. unless the employee consents in writing to become a party and the consent is filed in the court in which the action is brought. Notwithstanding s. 814.04 (1), the court shall, in addition to any judgment awarded to the plaintiff, allow reasonable attorney fees and costs to be paid by the defendant.

<b>BUILDING OR HEAVY CONSTRUCTION</b>
---------------------------------------

Includes sheltered enclosures with walk-in access for the purpose of housing persons, employees, machinery, equipment or supplies and non-sheltered work such as canals, dams, dikes, reservoirs, storage tanks, etc. A sheltered enclosure need not be "habitable" in order to be considered a building. The installation of machinery and/or equipment, both above and below grade level, does not change a project's character as a building. On-site grading, utility work and landscaping are included within this definition. Residential buildings of four (4) stories or less, agricultural buildings, parking lots and driveways are NOT included within this definition.

<b>SKILLED TRADES</b>
-----------------------

<u>CODE</u>	<u>TRADE OR OCCUPATION</u>	<u>HOURLY BASIC RATE OF PAY</u>	<u>HOURLY FRINGE BENEFITS</u>	<u>TOTAL</u>
		\$	\$	\$
101	Acoustic Ceiling Tile Installer	30.48	15.90	46.38
102	Boilermaker Future Increase(s): Add \$1.50/hr on 1/01/2015; Add \$1.50/hr. on 01/01/2016	32.05	28.04	60.09
103	Bricklayer, Blocklayer or Stonemason Premium Increase(s): DOT PREMIUM: Pay two times the hourly basic rate on Sunday, New Year's Day, Memorial Day, Independence Day, Labor Day, Thanksgiving Day & Christmas Day.	32.01	17.35	49.36
104	Cabinet Installer	30.48	15.90	46.38
105	Carpenter	30.48	15.90	46.38
106	Carpet Layer or Soft Floor Coverer	30.48	15.90	46.38
107	Cement Finisher	31.58	16.13	47.71
108	Drywall Taper or Finisher	24.80	16.60	41.40
109	Electrician Premium Increase(s): DOT PREMIUM: Pay two times the hourly basic rate on Sunday, New Year's Day, Memorial Day, Independence Day, Labor Day, Thanksgiving Day & Christmas Day.	34.07	19.25	53.32
110	Elevator Constructor	42.86	23.84	66.70
111	Fence Erector	24.72	0.00	24.72
112	Fire Sprinkler Fitter	36.07	18.73	54.80
113	Glazier	38.03	13.42	51.45
114	Heat or Frost Insulator	33.68	24.31	57.99
115	Insulator (Batt or Blown)	15.00	9.50	24.50
116	Ironworker	31.25	19.46	50.71
117	Lather	30.48	15.90	46.38



<b>Fringe Benefits Must Be Paid On <u>All</u> Hours Worked</b>		<b>HOURLY BASIC RATE OF PAY</b>	<b>HOURLY FRINGE BENEFITS</b>	<b>TOTAL</b>
<b>CODE</b>	<b>TRADE OR OCCUPATION</b>	<b>\$</b>	<b>\$</b>	<b>\$</b>
118	Line Constructor (Electrical)	38.25	17.31	55.56
119	Marble Finisher	26.89	19.18	46.07
120	Marble Mason	32.01	17.35	49.36
121	Metal Building Erector	22.00	10.00	32.00
122	Millwright	32.11	15.95	48.06
123	Overhead Door Installer	20.95	4.94	25.89
124	Painter	24.50	16.60	41.10
125	Pavement Marking Operator	30.00	0.00	30.00
126	Piledriver	30.98	15.90	46.88
127	Pipeline Fuser or Welder (Gas or Utility)	30.79	19.74	50.53
129	Plasterer	31.03	17.71	48.74
130	Plumber Future Increase(s): Add \$1/hr on 6/1/2014.	36.42	16.87	53.29
132	Refrigeration Mechanic	41.60	16.71	58.31
133	Roofer or Waterproofor	29.40	6.25	35.65
134	Sheet Metal Worker	34.45	22.57	57.02
135	Steamfitter Future Increase(s): Add \$1.70/hr on 6/1/2014.	42.95	17.81	60.76
137	Teledata Technician or Installer Premium Increase(s): DOT PREMIUM: Pay two times the hourly basic rate on Sunday, New Year's Day, Memorial Day, Independence Day, Labor Day, Thanksgiving Day & Christmas Day.	22.25	12.24	34.49
138	Temperature Control Installer	32.94	18.80	51.74
139	Terrazzo Finisher	26.89	19.18	46.07
140	Terrazzo Mechanic	30.20	18.42	48.62
141	Tile Finisher	23.85	17.18	41.03
142	Tile Setter	29.81	17.18	46.99
143	Tuckpointer, Caulker or Cleaner	35.25	13.15	48.40
144	Underwater Diver (Except on Great Lakes)	34.48	15.90	50.38
146	Well Driller or Pump Installer	25.32	15.65	40.97
147	Siding Installer	25.92	18.04	43.96

<b>Fringe Benefits Must Be Paid On <u>All</u> Hours Worked</b>		<b>HOURLY BASIC RATE OF PAY</b>	<b>HOURLY FRINGE BENEFITS</b>	<b>TOTAL</b>
<b>CODE</b>	<b>TRADE OR OCCUPATION</b>	<b>\$</b>	<b>\$</b>	<b>\$</b>
150	Heavy Equipment Operator - ELECTRICAL LINE CONSTRUCTION ONLY	29.16	14.34	43.50
151	Light Equipment Operator -ELECTRICAL LINE CONSTRUCTION ONLY	30.60	14.86	45.46
152	Heavy Truck Driver - ELECTRICAL LINE CONSTRUCTION ONLY	26.78	13.63	40.41
153	Light Truck Driver - ELECTRICAL LINE CONSTRUCTION ONLY	24.86	12.97	37.83
154	Groundman - ELECTRICAL LINE CONSTRUCTION ONLY	28.74	17.27	46.01

#### TRUCK DRIVERS

<b>Fringe Benefits Must Be Paid On <u>All</u> Hours Worked</b>		<b>HOURLY BASIC RATE OF PAY</b>	<b>HOURLY FRINGE BENEFITS</b>	<b>TOTAL</b>
<b>CODE</b>	<b>TRADE OR OCCUPATION</b>	<b>\$</b>	<b>\$</b>	<b>\$</b>
201	Single Axle or Two Axle	32.39	18.46	50.85
203	Three or More Axle	18.00	22.88	40.88
204	Articulated, Euclid, Dumptor, Off Road Material Hauler	32.89	18.96	51.85
205	Pavement Marking Vehicle	18.00	22.88	40.88
207	Truck Mechanic	18.00	22.88	40.88

#### LABORERS

<b>Fringe Benefits Must Be Paid On <u>All</u> Hours Worked</b>		<b>HOURLY BASIC RATE OF PAY</b>	<b>HOURLY FRINGE BENEFITS</b>	<b>TOTAL</b>
<b>CODE</b>	<b>TRADE OR OCCUPATION</b>	<b>\$</b>	<b>\$</b>	<b>\$</b>
301	General Laborer Premium Increase(s): Add \$1.00/hr for certified welder; Add \$.25/hr for mason tender	24.21	14.63	38.84
302	Asbestos Abatement Worker	24.36	14.44	38.80
303	Landscaper	21.01	9.37	30.38
310	Gas or Utility Pipeline Laborer (Other Than Sewer and Water)	21.01	13.63	34.64
311	Fiber Optic Laborer (Outside, Other Than Concrete Encased) Premium Increase(s): DOT PREMIUMS: Pay two times the hourly basic rate on New Year's Day, Memorial Day, Independence Day, Labor Day, Thanksgiving Day & Christmas Day.	18.33	13.65	31.98
314	Railroad Track Laborer	23.46	3.30	26.76
315	Final Construction Clean-Up Worker	16.00	0.00	16.00

**HEAVY EQUIPMENT OPERATORS  
SITE PREPARATION, UTILITY OR LANDSCAPING WORK ONLY**

<b>Fringe Benefits Must Be Paid On <u>All</u> Hours Worked</b>		<b>HOURLY BASIC RATE OF PAY</b>	<b>HOURLY FRINGE BENEFITS</b>	<b>TOTAL</b>
<b>CODE</b>	<b>TRADE OR OCCUPATION</b>	<b>\$</b>	<b>\$</b>	<b>\$</b>
501	Air Track, Rotary or Percussion Drilling Machine &/or Hammers, Blaster; Asphalt Milling Machine; Boring Machine (Directional, Horizontal or Vertical); Backhoe (Track Type) Having a Mfgr's Rated Capacity of 130,000 Lbs. or Over; Backhoe (Track Type) Having a Mfgr's Rated Capacity of Under 130,000 Lbs., Backhoe (Mini, 15,000 Lbs. & Under); Bulldozer or Endloader (Over 40 hp); Compactor (Self-Propelled 85 Ft Total Drum Width & Over, or Tractor Mounted, Towed & Light Equipment); Concrete Batch Plant, Batch Hopper; Concrete Breaker (Large, Auto, Vibratory/Sonic, Manual or Remote); Crane, Shovel, Dragline, Clamshells; Forklift (Machinery Moving or Steel Erection, 25 Ft & Over); Gradall (Cruz-Aire Type); Grader or Motor Patrol; Master Mechanic; Mechanic or Welder; Robotic Tool Carrier (With or Without Attachments); Scraper (Self Propelled or Tractor Drawn) 5 cu yds or More Capacity; Tractor or Truck Mounted Hydraulic Backhoe; Tractor or Truck Mounted Hydraulic Crane (10 Tons or Under); Tractor (Scraper, Dozer, Pusher, Loader); Trencher (Wheel Type or Chain Type Having Over 8 Inch Bucket).	33.42	18.96	52.38
502	Backfiller; Broom or Sweeper; Bulldozer or Endloader (Under 40 hp); Environmental Burner; Forestry Equipment, Timbco, Tree Shear, Tub Grinder, Processor; Jeep Digger; Screed (Milling Machine); Skid Rig; Straddle Carrier or Travel Lift; Stump Chipper; Trencher (Wheel Type or Chain Type Having 8 Inch Bucket & Under).	32.89	18.96	51.85
503	Air Compressor (&/or 400 CFM or Over); Augers (Vertical & Horizontal); Compactor (Self-Propelled 84 Ft Total Drum Width & Under, or Tractor Mounted, Towed & Light Equipment); Crusher, Screening or Wash Plant; Farm or Industrial Type Tractor; Forklift; Generator (&/or 150 KW or Over); Greaser; High Pressure Utility Locating Machine (Daylighting Machine); Mulcher; Oiler; Post Hole Digger or Driver; Pump (3 Inch or Over) or Well Points; Refrigeration Plant or Freeze Machine; Rock, Stone Breaker; Skid Steer Loader (With or Without Attachments); Vibratory Hammer or Extractor, Power Pack.	30.82	18.96	49.78
504	Work Performed on the Great Lakes Including Diver; Wet Tender or Hydraulic Dredge Engineer.	38.80	18.98	57.78
505	Work Performed on the Great Lakes Including Crane or Backhoe Operator; Assistant Hydraulic Dredge Engineer; Hydraulic Dredge Leverman or Diver's Tender; Mechanic or Welder; 70 Ton & Over Tug Operator.	38.80	18.98	57.78
506	Work Performed on the Great Lakes Including Deck Equipment Operator or Machineryman (Maintains Cranes Over 50 Tons or Backhoes 115,000 Lbs. or More); Tug, Launch or Loader, Dozer or Like Equipment When Operated on a Barge, Breakwater Wall, Slip, Dock or Scow, Deck Machinery.	34.50	18.98	53.48

507	Work Performed on the Great Lakes Including Deck Equipment Operator, Machineryman or Fireman (Operates 4 Units or More or Maintains Cranes 50 Tons or Under or Backhoes 115,000 Lbs. or Under); Deck Hand, Deck Engineer or Assistant Tug Operator; Off Road Trucks - Great Lakes ONLY.	34.50	18.98	53.48
-----	---	-------	-------	-------

**HEAVY EQUIPMENT OPERATORS  
EXCLUDING SITE PREPARATION, UTILITY, PAVING LANDSCAPING WORK**

<b>CODE</b>	<b>TRADE OR OCCUPATION</b>	<b>Fringe Benefits Must Be Paid On <u>All</u> Hours Worked</b>		
		<b>HOURLY BASIC RATE OF PAY</b>	<b>HOURLY FRINGE BENEFITS</b>	<b>TOTAL</b>
		<b>\$</b>	<b>\$</b>	<b>\$</b>
508	Boring Machine (Directional); Crane, Tower Crane, Pedestal Tower or Derrick, With or Without Attachments, With a Lifting Capacity of Over 100 Tons, Self-Erecting Tower Crane With a Lifting Capacity of Over 4,000 Lbs., Crane With Boom Dollies; Crane, Tower Crane, Pedestal Tower or Derrick, With Boom, Leads &/or Jib Lengths Measuring 176 Ft or Over; Master Mechanic. Premium Increase(s): Add \$.50/hr for >200 Ton / Add \$1/hr at 300 Ton / Add \$1.50/hr at 400 Ton / Add \$2/hr at 500 Ton & Over.	35.62	18.96	54.58
509	Backhoe (Track Type) Having a Mfgr's Rated Capacity of 130,000 Lbs. or Over; Boring Machine (Horizontal or Vertical); Caisson Rig; Crane, Tower Crane, Portable Tower, Pedestal Tower or Derrick, With or Without Attachments, With a Lifting Capacity of 100 Tons or Under, Self-Erecting Tower Crane With A Lifting Capacity Of 4,000 Lbs. & Under; Crane, Tower Crane, Portable Tower, Pedestal Tower or Derrick, With Boom, Leads &/or Jib Lengths Measuring 175 Ft or Under; Pile Driver; Versi Lifts, Tri-Lifts & Gantrys (20,000 Lbs. & Over).	36.35	6.95	43.30
510	Backhoe (Track Type) Having a Mfgr.'s Rated Capacity of Under 130,000 Lbs., Backhoe (Mini, 15,000 Lbs. & Under); Concrete Bump Cutter, Grinder, Planing or Grooving Machine; Concrete Laser/Screed; Concrete Paver (Slipform); Concrete Pump (Over 46 Meter), Concrete Conveyor (Rotec or Bidwell Type); Concrete Slipform Placer Curb & Gutter Machine; Concrete Spreader & Distributor; Dredge (NOT Performing Work on the Great Lakes); Forklift (Machinery Moving or Steel Erection, 25 Ft & Over); Gradall (Cruz-Aire Type); Hydro-Blaster (10,000 PSI or Over); Milling Machine; Skid Rig; Traveling Crane (Bridge Type).	33.42	18.96	52.38
511	Air, Track, Rotary or Percussion Drilling Machine &/or Hammers, Blaster; Bulldozer or Endloader (Over 40 hp); Compactor (Self-Propelled 85 Ft Total Drum Width & Over, or Tractor Mounted, Towed & Light Equipment); Concrete Pump (46 Meter & Under), Concrete Conveyor (Rotec or Bidwell Type); Crane (Carry Deck, Mini) or Truck Mounted Hydraulic Crane (10 Tons or Under); Environmental Burner; Gantrys (Under 20,000 Lbs.); Grader or Motor Patrol; High Pressure Utility Locating Machine (Daylighting Machine); Manhoist; Material or Stack Hoist; Mechanic or Welder; Railroad Track Rail Leveling Machine, Tie Placer, Extractor, Tamper, Stone Leveler or Rehabilitation Equipment; Roller (Over 5 Ton); Scraper (Self Propelled or Tractor Drawn) 5 cu yd or More Capacity; Screed (Milling Machine); Sideboom; Straddle Carrier or Travel Lift; Tining or Curing Machine; Tractor (Scraper, Dozer, Pusher, Loader); Tractor or Truck Mounted Hydraulic Backhoe; Tractor or Truck Mounted Hydraulic Crane (10 Tons or Under); Trencher (Wheel Type or Chain Type Having Over 8-Inch Bucket).	32.89	18.96	51.85

<b>Fringe Benefits Must Be Paid On <u>All</u> Hours Worked</b>		<b>HOURLY BASIC RATE OF PAY</b>	<b>HOURLY FRINGE BENEFITS</b>	<b>TOTAL</b>
<b>CODE</b>	<b>TRADE OR OCCUPATION</b>	<b>\$</b>	<b>\$</b>	<b>\$</b>
512	Backfiller; Broom or Sweeper; Bulldozer or Endloader (Under 40 hp); Compactor (Self-Propelled 84 Ft Total Drum Width & Under, or Tractor Mounted, Towed & Light Equipment); Concrete Batch Plant, Batch Hopper; Concrete Breaker (Large, Auto, Vibratory/Sonic, Manual or Remote); Concrete Conveyor System; Concrete Finishing Machine (Road Type); Fireman (Pile Driver & Derrick NOT Performing Work on the Great Lakes); Grout Pump; Hoist (Tugger, Automatic); Industrial Locomotives; Jeep Digger; Lift Slab Machine; Mulcher; Roller (Rubber Tire, 5 Ton or Under); Screw or Gypsum Pumps; Stabilizing or Concrete Mixer (Self-Propelled or 14S or Over); Stump Chipper; Trencher (Wheel Type or Chain Type Having 8-Inch Bucket & Under); Winches & A-Frames.	30.82	18.96	49.78
513	Air Compressor (&/or 400 CFM or Over); Air, Electric or Hydraulic Jacking System; Augers (Vertical & Horizontal); Boatmen (NOT Performing Work on the Great Lakes); Boiler (Temporary Heat); Crusher, Screening or Wash Plant; Elevator; Farm or Industrial Type Tractor; Fireman (Asphalt Plant NOT Performing Work on the Great Lakes); Forklift; Generator (&/or 150 KW or Over); Greaser; Heaters (Mechanical); Loading Machine (Conveyor); Oiler; Post Hole Digger or Driver; Prestress Machine; Pump (3 Inch or Over) or Well Points; Refrigeration Plant or Freeze Machine; Robotic Tool Carrier (With or Without Attachments); Rock, Stone Breaker; Skid Steer Loader (With or Without Attachments); Vibratory Hammer or Extractor, Power Pack.	24.19	17.89	42.08
514	Gas or Utility Pipeline, Except Sewer & Water (Primary Equipment).	36.34	21.14	57.48
515	Gas or Utility Pipeline, Except Sewer & Water (Secondary Equipment). Future Increase(s): Add \$1.60/hr on 06/01/2014; Add \$1.65/hr on 06/01/2015.	32.32	18.55	50.87
516	Fiber Optic Cable Equipment Future Increase(s): Add \$1.75/hr on 02/01/2014.	27.89	17.20	45.09

<b>SEWER, WATER OR TUNNEL CONSTRUCTION</b>
--

Includes those projects that primarily involve public sewer or water distribution, transmission or collection systems and related tunnel work (excluding buildings).

---

**SKILLED TRADES**

---

<b>CODE</b>	<b>TRADE OR OCCUPATION</b>	<b>HOURLY BASIC RATE OF PAY</b>	<b>HOURLY FRINGE BENEFITS</b>	<b>TOTAL</b>
		\$	\$	\$
103	Bricklayer, Blocklayer or Stonemason Premium Increase(s): DOT PREMIUM: Pay two times the hourly basic rate on Sunday, New Year's Day, Memorial Day, Independence Day, Labor Day, Thanksgiving Day & Christmas Day.	35.10	18.40	53.50
105	Carpenter Future Increase(s): Add \$1.25/hr on 6/2/2014. Premium Increase(s): DOT PREMIUM: Pay two times the hourly basic rate on Sunday, New Year's Day, Memorial Day, Independence Day, Labor Day, Thanksgiving Day & Christmas Day.	33.68	19.81	53.49
107	Cement Finisher Future Increase(s): Add \$1.87 on 6/1/14; Add \$1.87 on 6/1/15; Add \$1.75 on 6/1/16. Premium Increase(s): DOT PREMIUMS: 1) Pay two times the hourly basic rate on Sunday, New Year's Day, Memorial Day, Independence Day, Labor Day, Thanksgiving Day & Christmas Day. 2) Add \$1.40/hr when the Wisconsin Department of Transportation or responsible governing agency requires that work be performed at night under artificial illumination with traffic control and the work is completed after sunset and before sunrise.	33.51	16.13	49.64
109	Electrician Premium Increase(s): DOT PREMIUM: Pay two times the hourly basic rate on Sunday, New Year's Day, Memorial Day, Independence Day, Labor Day, Thanksgiving Day & Christmas Day.	32.82	22.61	55.43
111	Fence Erector	24.72	0.00	24.72
116	Ironworker	31.25	19.46	50.71
118	Line Constructor (Electrical)	38.25	17.31	55.56
125	Pavement Marking Operator	16.00	7.35	23.35
126	Piledriver	30.98	15.90	46.88
130	Plumber	33.75	14.07	47.82
135	Steamfitter	42.45	16.71	59.16
137	Teledata Technician or Installer	21.89	11.85	33.74

<b>Fringe Benefits Must Be Paid On <u>All</u> Hours Worked</b>		<b>HOURLY BASIC RATE OF PAY</b>	<b>HOURLY FRINGE BENEFITS</b>	<b>TOTAL</b>
<b>CODE</b>	<b>TRADE OR OCCUPATION</b>	<b>\$</b>	<b>\$</b>	<b>\$</b>
143	Tuckpointer, Caulker or Cleaner	35.25	13.15	48.40
144	Underwater Diver (Except on Great Lakes)	38.80	18.98	57.78
146	Well Driller or Pump Installer	25.32	15.65	40.97
150	Heavy Equipment Operator - ELECTRICAL LINE CONSTRUCTION ONLY	29.16	14.34	43.50
151	Light Equipment Operator -ELECTRICAL LINE CONSTRUCTION ONLY	30.60	14.86	45.46
152	Heavy Truck Driver - ELECTRICAL LINE CONSTRUCTION ONLY	26.78	13.63	40.41
153	Light Truck Driver - ELECTRICAL LINE CONSTRUCTION ONLY	24.86	12.97	37.83
154	Groundman - ELECTRICAL LINE CONSTRUCTION ONLY	21.75	12.70	34.45

### TRUCK DRIVERS

<b>Fringe Benefits Must Be Paid On <u>All</u> Hours Worked</b>		<b>HOURLY BASIC RATE OF PAY</b>	<b>HOURLY FRINGE BENEFITS</b>	<b>TOTAL</b>
<b>CODE</b>	<b>TRADE OR OCCUPATION</b>	<b>\$</b>	<b>\$</b>	<b>\$</b>
201	Single Axle or Two Axle	30.00	15.00	45.00
203	Three or More Axle	16.00	7.35	23.35
204	Articulated, Euclid, Dumptor, Off Road Material Hauler	32.89	18.96	51.85
205	Pavement Marking Vehicle	16.00	7.35	23.35
207	Truck Mechanic	16.00	7.35	23.35

### LABORERS

<b>Fringe Benefits Must Be Paid On <u>All</u> Hours Worked</b>		<b>HOURLY BASIC RATE OF PAY</b>	<b>HOURLY FRINGE BENEFITS</b>	<b>TOTAL</b>
<b>CODE</b>	<b>TRADE OR OCCUPATION</b>	<b>\$</b>	<b>\$</b>	<b>\$</b>
301	General Laborer Premium Increase(s): Add \$.20 for blaster, bracer, manhole builder, caulker, bottomman and power tool; Add \$.55 for pipelayer; Add \$1.00 for tunnel work 0-15 lbs. compressed air; Add \$2.00 for over 15-30 lbs. compressed air; Add \$3.00 for over 30 lbs. compressed air.	25.60	14.62	40.22
303	Landscaper	25.28	11.46	36.74
304	Flagperson or Traffic Control Person	24.70	10.72	35.42
311	Fiber Optic Laborer (Outside, Other Than Concrete Encased)	18.31	12.67	30.98
314	Railroad Track Laborer	23.46	3.30	26.76

**HEAVY EQUIPMENT OPERATORS  
SEWER, WATER OR TUNNEL WORK**

<b>Fringe Benefits Must Be Paid On <u>All</u> Hours Worked</b>		<b>HOURLY BASIC RATE OF PAY</b>	<b>HOURLY FRINGE BENEFITS</b>	<b>TOTAL</b>
<b>CODE</b>	<b>TRADE OR OCCUPATION</b>	<b>\$</b>	<b>\$</b>	<b>\$</b>
521	Backhoe (Track Type) Having a Mfgr.'s Rated Capacity of 130,000 Lbs. or Over; Caisson Rig; Crane, Tower Crane, Pedestal Tower or Derrick, With Boom, Leads &/or Jib Lengths Measuring 176 Ft or Over; Crane, Tower Crane, Pedestal Tower or Derrick, With or Without Attachments, With a Lifting Capacity of Over 100 Tons, Self-Erecting Tower Crane With a Lifting Capacity Of Over 4,000 Lbs., Crane With Boom Dollies; Master Mechanic; Pile Driver. Premium Increase(s): Add \$.25/hr for all >45 Ton lifting capacity cranes	34.62	18.96	53.58
522	Backhoe (Track Type) Having a Mfgr.'s Rated Capacity of Under 130,000 Lbs., Backhoe (Mini, 15,000 Lbs. & Under); Boring Machine (Directional); Concrete Bump Cutter, Grinder, Planing or Grooving Machine; Concrete Laser/Screed; Concrete Paver (Slipform); Concrete Pump (Over 46 Meter), Concrete Conveyor (Rotec or Bidwell Type); Concrete Spreader & Distributor; Crane, Tower Crane, Portable Tower, Pedestal Tower or Derrick, With Boom, Leads &/or Jib Lengths Measuring 175 Ft or Under; Crane, Tower Crane, Portable Tower, Pedestal Tower or Derrick, With or Without Attachments, With a Lifting Capacity of 100 Tons or Under, Self-Erecting Tower Crane With a Lifting Capacity of 4,000 Lbs. & Under; Dredge (NOT Performing Work on the Great Lakes); Milling Machine; Skid Rig; Telehandler; Traveling Crane (Bridge Type).	33.42	18.96	52.38
523	Air Track, Rotary or Percussion Drilling Machine &/or Hammers, Blaster; Boring Machine (Horizontal or Vertical); Bulldozer or Endloader (Over 40 hp); Crane (Carry Deck, Mini) or Truck Mounted Hydraulic Crane (10 Tons or Under); Concrete Pump (46 Meter & Under), Concrete Conveyor (Rotec or Bidwell Type); Concrete Slipform Placer Curb & Gutter Machine; Gradall (Cruz-Aire Type); Grader or Motor Patrol; Hydro-Blaster (10,000 PSI or Over); Manhoist; Material or Stack Hoist; Mechanic or Welder; Roller (Over 5 Ton); Scraper (Self Propelled or Tractor Drawn) 5 cu yd or More Capacity; Screed (Milling Machine); Sideboom; Straddle Carrier or Travel Lift; Tractor (Scraper, Dozer, Pusher, Loader); Tractor or Truck Mounted Hydraulic Backhoe; Tractor or Truck Mounted Hydraulic Crane (10 Tons or Under); Trencher (Wheel Type or Chain Type Having Over 8-Inch Bucket).	32.89	18.96	51.85



<b>Fringe Benefits Must Be Paid On <u>All</u> Hours Worked</b>		<b>HOURLY BASIC RATE OF PAY</b>	<b>HOURLY FRINGE BENEFITS</b>	<b>TOTAL</b>
<b>CODE</b>	<b>TRADE OR OCCUPATION</b>	<b>\$</b>	<b>\$</b>	<b>\$</b>
524	Backfiller; Broom or Sweeper; Bulldozer or Endloader (Under 40 hp); Compactor (Self-Propelled 85 Ft Total Drum Width & Over, or Tractor Mounted, Towed & Light Equipment); Concrete Batch Plant, Batch Hopper; Concrete Breaker (Large, Auto, Vibratory/Sonic, Manual or Remote); Concrete Conveyor System; Concrete Finishing Machine (Road Type); Environmental Burner; Fireman (Pile Driver & Derrick NOT Performing Work on the Great Lakes); Forestry Equipment, Timbco, Tree Shear, Tub Grinder, Processor; Hoist (Tugger, Automatic); Grout Pump; Jeep Digger; Lift Slab Machine; Mulcher; Power Subgrader; Pump (3 Inch or Over) or Well Points; Robotic Tool Carrier (With or Without Attachments); Roller (Rubber Tire, 5 Ton or Under); Screw or Gypsum Pumps; Stabilizing or Concrete Mixer (Self-Propelled or 14S or Over); Stump Chipper; Tining or Curing Machine; Trencher (Wheel Type or Chain Type Having 8-Inch Bucket & Under); Winches & A-Frames. Future Increase(s): Add \$1.05/hr on 6/2/2014; Add \$1.55/hr on 6/1/2015. Premium Increase(s): Add \$.25/hr for operating tower crane.	35.11	19.45	54.56
525	Air Compressor (&/or 400 CFM or Over); Air, Electric or Hydraulic Jacking System; Augers (Vertical & Horizontal); Compactor (Self-Propelled 84 Ft Total Drum Width & Under, or Tractor Mounted, Towed & Light Equipment); Crusher, Screening or Wash Plant; Farm or Industrial Type Tractor; Fireman (Asphalt Plant NOT Performing Work on the Great Lakes); Generator (&/or 150 KW or Over); Heaters (Mechanical); High Pressure Utility Locating Machine (Daylighting Machine); Loading Machine (Conveyor); Post Hole Digger or Driver; Refrigeration Plant or Freeze Machine; Rock, Stone Breaker; Skid Steer Loader (With or Without Attachments); Vibratory Hammer or Extractor, Power Pack.	30.19	20.94	51.13
526	Boiler (Temporary Heat); Forklift; Greaser; Oiler.	24.19	17.89	42.08
527	Work Performed on the Great Lakes Including Diver; Wet Tender or Hydraulic Dredge Engineer.	38.80	18.98	57.78
528	Work Performed on the Great Lakes Including 70 Ton & Over Tug Operator; Assistant Hydraulic Dredge Engineer; Crane or Backhoe Operator; Hydraulic Dredge Leverman or Diver's Tender; Mechanic or Welder.	38.80	18.98	57.78
529	Work Performed on the Great Lakes Including Deck Equipment Operator or Machineryman (Maintains Cranes Over 50 Tons or Backhoes 115,000 Lbs. or More); Tug, Launch or Loader, Dozer or Like Equipment When Operated on a Barge, Breakwater Wall, Slip, Dock or Scow, Deck Machinery.	34.50	18.98	53.48
530	Work Performed on the Great Lakes Including Deck Equipment Operator; Machineryman or Fireman (Operates 4 Units or More or Maintains Cranes 50 Tons or Under or Backhoes 115,000 Lbs. or Under), Deck Hand, Deck Engineer or Assistant Tug Operator; Off Road Trucks - Great Lakes ONLY.	34.50	18.98	53.48

<b>LOCAL STREET OR MISCELLANEOUS PAVING CONSTRUCTION</b>
--

Includes roads, streets, alleys, trails, bridges, paths, racetracks, parking lots and driveways (except residential or agricultural), public sidewalks or other similar projects (excluding projects awarded by the Wisconsin Department of Transportation).

---

**SKILLED TRADES**

---

Fringe Benefits Must Be Paid On <u>All</u> Hours Worked		HOURLY BASIC RATE OF PAY	HOURLY FRINGE BENEFITS	TOTAL
<u>CODE</u>	<u>TRADE OR OCCUPATION</u>	\$	\$	\$
103	Bricklayer, Blocklayer or Stonemason	32.01	17.35	49.36
105	Carpenter	32.93	19.93	52.86
107	Cement Finisher	31.48	15.68	47.16
109	Electrician	31.27	22.81	54.08
111	Fence Erector	24.72	0.00	24.72
116	Ironworker	31.25	19.46	50.71
118	Line Constructor (Electrical)	38.25	17.31	55.56
124	Painter	24.50	16.60	41.10
125	Pavement Marking Operator	30.00	0.00	30.00
126	Piledriver	30.98	15.90	46.88
133	Rofer or Waterproofer	29.40	6.25	35.65
137	Teledata Technician or Installer	21.89	11.85	33.74
143	Tuckpointer, Caulker or Cleaner	35.25	13.15	48.40
144	Underwater Diver (Except on Great Lakes)	38.80	18.98	57.78
150	Heavy Equipment Operator - ELECTRICAL LINE CONSTRUCTION ONLY	34.43	15.24	49.67
151	Light Equipment Operator -ELECTRICAL LINE CONSTRUCTION ONLY	30.60	14.86	45.46
152	Heavy Truck Driver - ELECTRICAL LINE CONSTRUCTION ONLY	26.78	13.63	40.41
153	Light Truck Driver - ELECTRICAL LINE CONSTRUCTION ONLY	24.86	12.97	37.83
154	Groundman - ELECTRICAL LINE CONSTRUCTION ONLY	21.75	12.70	34.45

---

**TRUCK DRIVERS**

---

Fringe Benefits Must Be Paid On <u>All</u> Hours Worked		HOURLY BASIC RATE OF PAY	HOURLY FRINGE BENEFITS	TOTAL
<u>CODE</u>	<u>TRADE OR OCCUPATION</u>	\$	\$	\$
201	Single Axle or Two Axle	30.00	15.00	45.00

<b>Fringe Benefits Must Be Paid On <u>All</u> Hours Worked</b>		<b>HOURLY BASIC RATE OF PAY</b>	<b>HOURLY FRINGE BENEFITS</b>	<b>TOTAL</b>
<b>CODE</b>	<b>TRADE OR OCCUPATION</b>	<b>\$</b>	<b>\$</b>	<b>\$</b>
203	Three or More Axle	17.00	0.00	17.00
204	Articulated, Euclid, Dumptor, Off Road Material Hauler	32.89	18.96	51.85
205	Pavement Marking Vehicle	17.00	0.00	17.00
206	Shadow or Pilot Vehicle	30.00	15.00	45.00
207	Truck Mechanic	17.00	0.00	17.00

**LABORERS**

<b>Fringe Benefits Must Be Paid On <u>All</u> Hours Worked</b>		<b>HOURLY BASIC RATE OF PAY</b>	<b>HOURLY FRINGE BENEFITS</b>	<b>TOTAL</b>
<b>CODE</b>	<b>TRADE OR OCCUPATION</b>	<b>\$</b>	<b>\$</b>	<b>\$</b>
301	General Laborer	28.07	13.25	41.32
303	Landscaper Future Increase(s): Add \$1.60/hr on 6/1/14. Premium Increase(s): DOT PREMIUMS: 1) Pay two times the hourly basic rate on Sunday, New Year's Day, Memorial Day, Independence Day, Labor Day, Thanksgiving Day & Christmas Day. 2) Add \$1.25/hr for work on projects involving temporary traffic control setup, for lane and shoulder closures, when work under artificial illumination conditions is necessary as required by the project provisions (including prep time prior to and/or cleanup after such time period).	29.04	14.63	43.67
304	Flagperson or Traffic Control Person	24.70	10.72	35.42
311	Fiber Optic Laborer (Outside, Other Than Concrete Encased)	18.31	12.67	30.98
314	Railroad Track Laborer	23.46	3.30	26.76

**HEAVY EQUIPMENT OPERATORS  
CONCRETE PAVEMENT OR BRIDGE WORK**

<b>Fringe Benefits Must Be Paid On <u>All</u> Hours Worked</b>		<b>HOURLY BASIC RATE OF PAY</b>	<b>HOURLY FRINGE BENEFITS</b>	<b>TOTAL</b>
<b>CODE</b>	<b>TRADE OR OCCUPATION</b>	<b>\$</b>	<b>\$</b>	<b>\$</b>
541	Crane, Tower Crane, Pedestal Tower or Derrick, With or Without Attachments, With a Lifting Capacity of Over 100 Tons, Self-Erecting Tower Crane With a Lifting Capacity Of Over 4,000 Lbs., Crane With Boom Dollies; Crane, Tower Crane, Pedestal Tower or Derrick, With Boom, Leads &/or Jib Lengths Measuring 176 Ft or Over; Master Mechanic. Future Increase(s): Add \$1.75/hr on 6/1/2014; Add \$1.25/hr on 6/1/2015; Add \$1.30/hr on 6/1/2016; Add \$1.25/hr on 6/1/2017. Premium Increase(s): DOT PREMIUMS: 1) Pay two times the hourly basic rate on Sunday, New Year's Day, Memorial Day, Independence Day, Labor Day, Thanksgiving Day & Christmas Day. 2) Add \$1.50/hr night work premium. See DOT's website for details about the applicability of this night work premium at: <a href="http://roadwaystandards.dot.wi.gov/hcci/labor-wages-eeo/index.shtm">http://roadwaystandards.dot.wi.gov/hcci/labor-wages-eeo/index.shtm</a> .	36.72	20.40	57.12
542	Backhoe (Track Type) Having a Mfgr.'s Rated Capacity of 130,000 Lbs. or Over; Caisson Rig; Crane, Tower Crane, Portable Tower, Pedestal Tower or Derrick, With or Without Attachments, With a Lifting Capacity of 100 Tons or Under, Self-Erecting Tower Crane With a Lifting Capacity of 4,000 Lbs. & Under; Crane, Tower Crane Portable Tower, Pedestal Tower or Derrick, With Boom, Leads &/or Jib Lengths Measuring 175 Ft or Under; Dredge (NOT Performing Work on the Great Lakes); Licensed Boat Pilot (NOT Performing Work on the Great Lakes); Pile Driver. Future Increase(s): Add \$1.75/hr on 6/1/2014; Add \$1.25/hr on 6/1/2015; Add \$1.30/hr on 6/1/2016; Add \$1.25/hr on 6/1/2017. Premium Increase(s): DOT PREMIUMS: 1) Pay two times the hourly basic rate on Sunday, New Year's Day, Memorial Day, Independence Day, Labor Day, Thanksgiving Day & Christmas Day. 2) Add \$1.50/hr night work premium. See DOT's website for details about the applicability of this night work premium at: <a href="http://roadwaystandards.dot.wi.gov/hcci/labor-wages-eeo/index.shtm">http://roadwaystandards.dot.wi.gov/hcci/labor-wages-eeo/index.shtm</a> .	36.22	20.40	56.62

<b>Fringe Benefits Must Be Paid On <u>All</u> Hours Worked</b>		<b>HOURLY BASIC RATE OF PAY</b>	<b>HOURLY FRINGE BENEFITS</b>	<b>TOTAL</b>
<b>CODE</b>	<b>TRADE OR OCCUPATION</b>	<b>\$</b>	<b>\$</b>	<b>\$</b>
543	<p>Air Track, Rotary or Percussion Drilling Machine &amp;/or Hammers, Blaster; Automatic Subgrader (Concrete); Backhoe (Track Type) Having a Mfgr.'s Rated Capacity of Under 130,000 Lbs., Backhoe (Mini, 15,000 Lbs. &amp; Under); Boring Machine (Directional, Horizontal or Vertical); Bridge (Bidwell) Paver; Bulldozer or Endloader; Concrete Batch Plant, Batch Hopper; Concrete Breaker (Large, Auto, Vibratory/Sonic, Manual or Remote); Concrete Bump Cutter, Grinder, Planing or Grooving Machine; Concrete Conveyor System; Concrete Laser/Screed; Concrete Paver (Slipform); Concrete Pump, Concrete Conveyor (Rotec or Bidwell Type); Concrete Slipform Placer Curb &amp; Gutter Machine; Concrete Spreader &amp; Distributor; Crane (Carry Deck, Mini) or Truck Mounted Hydraulic Crane (10 Tons or Under); Crane With a Lifting Capacity of 25 Tons or Under; Forestry Equipment, Timbco, Tree Shear, Tub Grinder, Processor; Gradall (Cruz-Aire Type); Grader or Motor Patrol; Grout Pump; Hydro-Blaster (10,000 PSI or Over); Loading Machine (Conveyor); Manhoist; Material or Stack Hoist; Mechanic or Welder; Milling Machine; Post Hole Digger or Driver; Scraper (Self Propelled or Tractor Drawn) 5 cu yds or More Capacity; Shoulder Widener; Sideboom; Skid Rig; Stabilizing or Concrete Mixer (Self-Propelled or 14S or Over); Straddle Carrier or Travel Lift; Tractor (Scraper, Dozer, Pusher, Loader); Tractor or Truck Mounted Hydraulic Backhoe; Trencher (Wheel Type or Chain Type); Tube Finisher; Tugger (NOT Performing Work on the Great Lakes); Winches &amp; A-Frames.</p> <p>Future Increase(s):            Add \$1.75/hr on 6/1/2014; Add \$1.25/hr on 6/1/2015;            Add \$1.30/hr on 6/1/2016; Add \$1.25/hr on 6/1/2017.</p> <p>Premium Increase(s):            DOT PREMIUMS: 1) Pay two times the hourly basic rate on Sunday, New Year's Day, Memorial Day, Independence Day, Labor Day, Thanksgiving Day &amp; Christmas Day. 2) Add \$1.50/hr night work premium.            See DOT's website for details about the applicability of this night work premium at: <a href="http://roadwaystandards.dot.wi.gov/hcci/labor-wages-eeo/index.shtm">http://roadwaystandards.dot.wi.gov/hcci/labor-wages-eeo/index.shtm</a>.</p>	35.72	20.40	56.12
544	<p>Backfiller; Belting, Burlap, Texturing Machine; Broom or Sweeper; Compactor (Self-Propelled or Tractor Mounted, Towed &amp; Light Equipment); Concrete Finishing Machine (Road Type); Environmental Burner; Farm or Industrial Type Tractor; Fireman (Pile Driver &amp; Derrick NOT Performing Work on the Great Lakes); Forklift; Greaser; Jeep Digger; Joint Sawyer (Multiple Blade); Launch (NOT Performing Work on the Great Lakes); Lift Slab Machine; Mechanical Float; Mulcher; Power Subgrader; Robotic Tool Carrier (With or Without Attachments); Self Propelled Chip Spreader; Shouldering Machine; Skid Steer Loader (With or Without Attachments); Telehandler; Tining or Curing Machine.</p>	33.96	19.79	53.75
545	<p>Air Compressor (&amp;/or 400 CFM or Over); Air, Electric or Hydraulic Jacking System; Automatic Belt Conveyor &amp; Surge Bin; Boiler (Temporary Heat); Concrete Proportioning Plant; Crusher, Screening or Wash Plant; Generator (&amp;/or 150 KW or Over); Heaters (Mechanical); High Pressure Utility Locating Machine (Daylighting Machine); Mudjack; Oiler; Prestress Machine; Pug Mill; Pump (3 Inch or Over) or Well Points; Rock, Stone Breaker; Screed (Milling Machine); Stump Chipper; Tank Car Heaters; Vibratory Hammer or Extractor, Power Pack.</p>	30.32	18.46	48.78
546	Fiber Optic Cable Equipment.	26.69	16.65	43.34

<b>Fringe Benefits Must Be Paid On <u>All</u> Hours Worked</b>				
<b><u>CODE</u></b>	<b><u>TRADE OR OCCUPATION</u></b>	<b><u>HOURLY BASIC RATE OF PAY</u></b>	<b><u>HOURLY FRINGE BENEFITS</u></b>	<b><u>TOTAL</u></b>
		<b>\$</b>	<b>\$</b>	<b>\$</b>
547	Work Performed on the Great Lakes Including Diver; Wet Tender or Hydraulic Dredge Engineer.	38.80	18.98	57.78
548	Work Performed on the Great Lakes Including 70 Ton & Over Tug Operator; Assistant Hydraulic Dredge Engineer; Crane or Backhoe Operator; Hydraulic Dredge Leverman or Diver's Tender; Mechanic or Welder.	38.80	18.98	57.78
549	Work Performed on the Great Lakes Including Deck Equipment Operator or Machineryman (Maintains Cranes Over 50 Tons or Backhoes 115,000 Lbs. or more); Tug, Launch or Loader, Dozer or Like Equipment When Operated on a Barge, Breakwater Wall, Slip, Dock or Scow, Deck Machinery.	34.50	18.98	53.48
550	Work Performed on the Great Lakes Including Deck Equipment Operator; Machineryman or Fireman (Operates 4 Units or More or Maintains Cranes 50 Tons or Under or Backhoes 115,000 Lbs. or Under); Deck Hand, Deck Engineer or Assistant Tug Operator; Off Road Trucks - Great Lakes ONLY.	34.50	18.98	53.48

**HEAVY EQUIPMENT OPERATORS  
ASPHALT PAVEMENT OR OTHER WORK**

<b>Fringe Benefits Must Be Paid On <u>All</u> Hours Worked</b>				
<b><u>CODE</u></b>	<b><u>TRADE OR OCCUPATION</u></b>	<b><u>HOURLY BASIC RATE OF PAY</u></b>	<b><u>HOURLY FRINGE BENEFITS</u></b>	<b><u>TOTAL</u></b>
		<b>\$</b>	<b>\$</b>	<b>\$</b>
551	Crane, Tower Crane, Pedestal Tower or Derrick, With or Without Attachments, With a Lifting Capacity of Over 100 Tons, Self Erecting Tower Crane With a Lifting Capacity of Over 4,000 Lbs., Crane With Boom Dollies; Crane, Tower Crane, Pedestal Tower or Derrick, With Boom, Leads and/or Jib Lengths Measuring 176 Ft or Over; Master Mechanic.	35.12	18.46	53.58
552	Backhoe (Track Type) Having a Mfgr.'s Rated Capacity of 130,000 Lbs. or Over; Caisson Rig; Crane, Tower Crane, Portable Tower, Pedestal Tower or Derrick, With or Without Attachments, With a Lifting Capacity of 100 Tons or Under, Self-Erecting Tower Crane With a Lifting Capacity Of 4,000 Lbs. & Under; Crane, Tower Crane, Portable Tower, Pedestal Tower or Derrick, With Boom, Leads &/or Jib Lengths Measuring 175 Ft or Under; Dredge (NOT Performing Work on the Great Lakes); Licensed Boat Pilot (NOT Performing Work on the Great Lakes); Pile Driver. Future Increase(s): Add \$1.75/hr on 6/1/2014; Add \$1.25/hr on 6/1/2015; Add \$1.30/hr on 6/1/2016; Add \$1.25/hr on 6/1/2017. Premium Increase(s): DOT PREMIUMS: 1) Pay two times the hourly basic rate on Sunday, New Year's Day, Memorial Day, Independence Day, Labor Day, Thanksgiving Day & Christmas Day. 2) Add \$1.50/hr night work premium. See DOT's website for details about the applicability of this night work premium at: <a href="http://roadwaystandards.dot.wi.gov/hcci/labor-wages-eeo/index.shtm">http://roadwaystandards.dot.wi.gov/hcci/labor-wages-eeo/index.shtm</a> .	36.22	20.40	56.62

<b>Fringe Benefits Must Be Paid On <u>All</u> Hours Worked</b>		<b>HOURLY BASIC RATE OF PAY</b>	<b>HOURLY FRINGE BENEFITS</b>	<b>TOTAL</b>
<b>CODE</b>	<b>TRADE OR OCCUPATION</b>	<b>\$</b>	<b>\$</b>	<b>\$</b>
553	Air, Track, Rotary or Percussion Drilling Machine &/or Hammers, Blaster; Asphalt Heater, Planer & Scarifier; Asphalt Milling Machine; Asphalt Screed; Backhoe (Track Type) Having a Mfgr.'s Rated Capacity of Under 130,000 Lbs., Backhoe (Mini, 15,000 Lbs. & Under); Bituminous (Asphalt) Plant & Paver, Screed; Boring Machine (Directional, Horizontal or Vertical); Bulldozer or Endloader; Concrete Breaker (Large, Auto, Vibratory/Sonic, Manual or Remote); Concrete Conveyor System; Concrete Laser/Screed; Concrete Slipform Placer Curb & Gutter Machine; Crane (Carry Deck, Mini) or Truck Mounted Hydraulic Crane (10 Tons or Under); Crane With a Lifting Capacity of 25 Tons or Under; Forestry Equipment, Timbco, Tree Shear, Tub Grinder, Processor; Gradall (Cruz-Aire Type); Grader or Motor Patrol; Hydro-Blaster (10,000 PSI or Over); Loading Machine (Conveyor); Manhoist; Material or Stack Hoist; Mechanic or Welder; Milling Machine; Post Hole Digger or Driver; Railroad Track Rail Leveling Machine, Tie Placer, Extractor, Tamper, Stone Leveler or Rehabilitation Equipment; Roller (Over 5 Ton); Scraper (Self Propelled or Tractor Drawn) 5 cu yds or More Capacity; Shoulder Widener; Sideboom; Skid Rig; Stabilizing or Concrete Mixer (Self-Propelled or 14S or Over); Tractor (Scraper, Dozer, Pusher, Loader); Tractor or Truck Mounted Hydraulic Backhoe; Trencher (Wheel Type or Chain Type); Tube Finisher; Tugger (NOT Performing Work on the Great Lakes); Winches & A-Frames.	32.89	18.96	51.85
554	Backfiller; Broom or Sweeper; Compactor (Self-Propelled or Tractor Mounted, Towed & Light Equipment); Concrete Finishing Machine (Road Type); Environmental Burner; Farm or Industrial Type Tractor; Fireman (Asphalt Plant, Pile Driver & Derrick NOT Performing Work on the Great Lakes); Forklift; Greaser; Hoist (Tugger, Automatic); Jeep Digger; Joint Sawyer (Multiple Blade); Launch (NOT Performing Work on the Great Lakes); Lift Slab Machine; Mechanical Float; Mulcher; Power Subgrader; Robotic Tool Carrier (With or Without Attachments); Roller (Rubber Tire, 5 Ton or Under); Self-Propelled Chip Spreader; Shouldering Machine; Skid Steer Loader (With or Without Attachments); Telehandler.	33.67	19.48	53.15
555	Air Compressor (&/or 400 CFM or Over); Air, Electric or Hydraulic Jacking System; Augers (Vertical & Horizontal); Automatic Belt Conveyor & Surge Bin; Boiler (Temporary Heat); Crusher, Screening or Wash Plant; Generator (&/or 150 KW or Over); Heaters (Mechanical); High Pressure Utility Locating Machine (Daylighting Machine); Mudjack; Oiler; Prestress Machine; Pug Mill; Pump (3 Inch or Over) or Well Points; Rock, Stone Breaker; Screed (Milling Machine); Stump Chipper; Tank Car Heaters; Vibratory Hammer or Extractor, Power Pack. Future Increase(s): Add \$1.75/hr on 6/1/2014; Add \$1.25/hr on 6/1/2015; Add \$1.30/hr on 6/1/2016; Add \$1.25/hr on 6/1/2017. Premium Increase(s): DOT PREMIUMS: 1) Pay two times the hourly basic rate on Sunday, New Year's Day, Memorial Day, Independence Day, Labor Day, Thanksgiving Day & Christmas Day. 2) Add \$1.50/hr night work premium. See DOT's website for details about the applicability of this night work premium at: <a href="http://roadwaystandards.dot.wi.gov/hcci/labor-wages-eeo/index.shtm">http://roadwaystandards.dot.wi.gov/hcci/labor-wages-eeo/index.shtm</a> .	35.17	20.40	55.57
556	Fiber Optic Cable Equipment.	26.69	16.65	43.34

\*\*\*\*\* END OF RATES \*\*\*\*\*



Department of Workforce Development  
 Equal Rights Division  
 P.O. Box 8928  
 Madison, WI 53708-8928  
 Telephone: (608) 266-6860  
 Fax: (608) 267-4592  
 TTY: (608) 264-8752



Scott Walker, Governor  
 Reginald J. Newson, Secretary  
 Joe Handrick, Division Administrator

The documents following the Prevailing Wage Rate Determination consist of 18 pages of various forms/documents that will be used throughout the completion of the project. The chart below lists the form number, form/document name, the party who uses the document, and the document's number of pages. If you have any questions regarding these forms please call the Prevailing Wage Office at (608)266-6861.

ERD Form Number	Form Name	Party Who Uses the Form	Pages
16056	Post the White Sheet	Contracting agency	1
16770	Substance Abuse Prevention on Public Works and Publicly Funded Projects, §103.503, Wis. Stats.	All contractors working on public works and publicly funded private construction projects	1
10908	Consolidated List of Debarred Contractors	Any party contracting someone to complete work on a prevailing wage project	2
7777	Disclosure of Ownership	Contractors that meet the criteria set out in (3)(A)&(B) of the form	1
5724	Prime Contractor Affidavit of Compliance	Prime contractor files with contracting agency upon completion of the work before receiving final payment	2
10584	Agent or Subcontractor Affidavit of Compliance	Subcontractors file with their awarding contractor upon completion of their work on the project before receiving final payment	2
10880	Request to Employ Subjourneyperson	Contractors wishing to employ a subjourneyperson(s)	1
	Prevailing Wage - Public Entity Project Owners	Explanation of project owner responsibilities	2
	Prevailing Wage – Contractors	Explanation of contractor responsibilities	2
	Summary of Prevailing Wage Law Changes Effective July 1, 2011	Information for public entity or any other interested party	4

09/01/12

## **POST THE WHITE SHEET**

As the public entity receiving this prevailing wage rate determination, YOU ARE REQUIRED by law to post the prevailing wage rate determination (i.e., white sheet) in at least one conspicuous and easily accessible place on the project site that is available to all construction workers. The white sheet must remain posted from the onset of the project until all construction labor on the project has been completed.

[See, Wis. Admin. Code §DWD 290.12(1)]

Posting the white sheet inside the general contractor's trailer does not meet this requirement. That placement is not available/accessible to all workers and is not a location over which you have control.

If you have questions about posting, please call (608)266-6861 and ask for prevailing wage intake.

## Disclaimer

**Employers performing work on public works and publicly funded private construction projects in Wisconsin are required to have a written substance abuse testing program in place. The provisions of this requirement are contained in Sec. 103.503, Wis. Stats. The Department of Workforce Development is neither responsible for enforcement of this law nor authorized to answer questions concerning its provisions. For legal advice on complying with Sec. 103.503, Wis. Stats., you may wish to consult with a private attorney.**

### **103.503 Substance abuse prevention on public works and publicly funded projects. (1) DEFINITIONS.** In this section:

(a) "Accident" means an incident caused, contributed to, or otherwise involving an employee that resulted or could have resulted in death, personal injury, or property damage and that occurred while the employee was performing the work described in s. 66.0903 (4), 66.0904 (3), or 103.49 (2m) on a project.

(b) "Alcohol" has the meaning given in s. 340.01 (1q).

(c) "Contracting agency" means a local governmental unit, as defined in s. 66.0903 (1) (d), a state agency, as defined in s. 103.49 (1) (f), or an owner or developer under s. 66.0904 that has contracted for the performance of work on a project.

(d) "Drug" means any controlled substance, as defined in s. 961.01 (4), or controlled substance analog, as defined in s. 961.01 (4m), for which testing is required by an employer under its substance abuse prevention program under this section.

(e) "Employee" means a laborer, worker, mechanic, or truck driver who performs the work described in s. 66.0903 (4), 66.0904 (3), or 103.49 (2m) on a project.

(f) "Employer" means a contractor, subcontractor, or agent of a contractor or subcontractor that performs work on a project.

(g) "Project" mean a project of public works that is subject to s. 66.0903 or 103.49 or a publicly funded private construction project that is subject to s. 66.0904.

(2) **SUBSTANCE ABUSE PROHIBITED.** No employee may use, possess, attempt to possess, distribute, deliver, or be under the influence of a drug, or use or be under the influence of alcohol, while performing the work described in s. 66.0903 (4), 66.0904 (3), or 103.49 (2m) on a project. An employee is considered to be under the influence of alcohol for purposes of this subsection if he or she has an alcohol concentration that is equal to or greater than the amount specified in s. 885.235 (1g) (d).

(3) **SUBSTANCE ABUSE PREVENTION PROGRAMS REQUIRED.** (a) Before an employer may commence work on a project, the employer shall have in place a written program for the prevention of substance abuse among its employees. At a minimum, the program shall include all of the following:

1. A prohibition against the actions or conditions specified in sub. (2).

2. A requirement that employees performing the work described in s. 66.0903 (4), 66.0904 (3), or 103.49 (2m) on a project submit to random, reasonable suspicion, and post-accident drug and alcohol testing and to drug and alcohol testing before commencing work on a project, except that testing of an employee before commencing work on a project is not required if the employee has been participating in a random testing program during the 90 days preceding the date on which the employee commenced work on the project.

3. A procedure for notifying an employee who violates sub. (2), who tests positive for the presence of a drug in his or her system, or who refuses to submit to drug or alcohol testing as required under the program that the employee may not perform work on a project until he or she meets the conditions specified in sub. (4) (b) 1. and 2.

(b) Each employer shall be responsible for the cost of developing, implementing, and enforcing its substance abuse prevention program, including the cost of drug and alcohol testing of its employees under the program. The contracting agency is not responsible for that cost, for the cost of any medical review of a test result, or for any rehabilitation provided to an employee.

(4) **EMPLOYEE ACCESS TO PROJECT.** (a) No employer may permit an employee who violates sub. (2), who tests positive for the presence of a drug in his or her system, or who refuses to submit to drug or alcohol testing as required under the employer's substance abuse prevention program under sub. (3) to perform work on a project until he or she meets the conditions specified in par. (b) 1. and 2. An employer shall immediately remove an employee from work on a project if any of the following occurs:

1. The employee violates sub. (2), tests positive for the presence of a drug in his or her system, or refuses to submit to drug or alcohol testing as required under the employer's substance abuse prevention program.

2. An officer or employee of the contracting agency has a reasonable suspicion that the employee is in violation of sub. (2) and requests the employer to immediately remove the employee from work on the project.

(b) An employee who is barred or removed from work on a project under par. (a) may commence or return to work on the project upon his or her employer providing to the contracting agency documentation showing all of the following:

1. That the employee has tested negative for the presence of drugs in his or her system and is not under the influence of alcohol as described in sub. (2).

2. That the employee has been approved to commence or return to work on the project in accordance with the employer's substance abuse prevention program.

(c) Testing for the presence of drugs or alcohol in an employee's system and the handling of test specimens shall be conducted in accordance with guidelines for laboratory testing procedures and chain-of-custody procedures established by the substance abuse and mental health services administration of the federal department of health and human services.

(5) **LOCAL ORDINANCES; STRICT CONFORMITY REQUIRED.** A local governmental unit, as defined in s. 66.0903 (1) (d), may enact an ordinance regulating the conduct regulated under this section only if the ordinance strictly conforms to this section.

History: 2005 a. 181; 2009 a. 28.

Consolidated List of Debarred Contractors  
Prepared and Issued By  
State of Wisconsin  
Department of Workforce Development

September 1, 2012

This list has been prepared in accordance with the provisions of s. 66.0903(12), s. 66.0904(10) and s. 103.49(7), Stats. and Chapter DWD 294 of the Wisconsin Administrative Code. All contractors on this list were found to have committed a "debarable offense" related to certain labor standard provisions determined or established for a state or local public works project or publicly funded private construction project. No state agency, local governmental unit or owner or developer may knowingly solicit bids from, negotiate with or award any contracts to or approve or allow any subcontracts with a debarred contractor, including all divisions, affiliates or other organizational elements of such contractor that are engaged in construction business activities, until the debarment is terminated. The name of each debarred contractor must remain on this list for a period of three (3) years from the termination date indicated below. The contractor is, however, only "debarred" from the "effective date" through the "termination date" indicated for that contractor. Questions regarding this list should be addressed to Julie Eckenwalder, Equal Rights Division, P. O. Box 8928, Madison, WI 53708 or call (608) 266-3148. Deaf, hearing or speech-impaired callers may contact the department by calling its TDD number (608) 264-8752.

<u>Name of Contractor</u>	<u>Address</u>	<u>Effective Date</u>	<u>Termination Date</u>	<u>Cause Code</u>	<u>Date of Violation(s)</u>	<u>Limitations/Deviations</u>
Abel, Mike	See, Abel Electric, Inc					
Abel Electric, Inc	3385 Belmar Rd Green Bay, WI 54313	9/1/12	8/31/2015	1	2011	None
Atkins, Scott	See, Freedom Insulation, Inc					
Boecker, Roger	See, R-Way Pumping, Inc					
Castlerock Commercial Construction, Inc	PO Box 11699 Milwaukee, WI 53211-0699	2/1/12	1/31/15	1, 2 and 4	2009 & 2010	None
Custom Heating & Air LLC	283 Tony Lane Green Bay, WI 54304	12/1/06	11/30/09	1, 2 and 4	2003 & 2004	None
Dem/Ex Group, Inc	805 S Adams St Manito, IL 61546	12/1/11	11/30/14	1 and 2	2010	None
Fisher, Ed &/or Fisher, Rhonda	See, Dem/Ex Group, Inc					
Freedom Insulation, Inc	117925 219 <sup>th</sup> Ave Chippewa Falls, WI 54729	9/1/11	8/31/14	1	2008- 2010	None

<u>Name of Contractor</u>	<u>Address</u>	<u>Effective Date</u>	<u>Termination Date</u>	<u>Cause Code</u>	<u>Date of Violation(s)</u>	<u>Limitations/Deviations</u>
JT Roofing, Inc	350 Tower Dr Saukville, WI 53080	6/1/11	5/31/15	1, 2 and 4	2007 & 2008	None
Jinkins, Richard	See, Castlerock Commercial Construction, Inc.					
Joseph Stoller Company	N8426 Hwy 42 Algoma, WI 54201	2/1/07	1/31/10	1 and 2	2004 & 2005	None
Keiver, David	See, Custom Heating & Air LLC					
Ofstie, Darin	See, Precision Excavating and Grading, LLC					
Precision Excavating and Grading, LLC or Precision Excavating Enterprises, LLC	2104 Pierce Saint Croix Rd Baldwin, WI 54002	5/1/11	4/30/14	1, 2 and 4	2006- 2008	None
R-Way Pumping, Inc	3023 Lake Maria Rd Freeport, MN 56331	3/1/12	2/28/15	1, 2 and 4	2008	None
Stoller Enterprises LLC	N8426 Hwy 42 Algoma, WI 54201-9552	2/1/2007	1/31/10	1 and 2	2005 to 2006	None
Stoller, Joseph	See, Joseph Stoller Company					
Stoller, Patrick J	See, Stoller Enterprises LLC					
Thull, Gerald T	See, JT Roofing, Inc.					

Cause Code: 1 = Failure to Pay Straight Time 2 = Failure to Pay Overtime 3 = Kickback 4 = Payroll Records.

## Disclosure of Ownership

The statutory authority for the use of this form is prescribed in Sections 66.0903(12)(d), 66.0904(10)(d) and 103.49(7)(d), Wisconsin Statutes.

The use of this form is mandatory. The penalty for failing to complete this form is prescribed in Section 103.005(12), Wisconsin Statutes.

Personal information you provide may be used for secondary purposes [Privacy Law, s. 15.04(1) (m), Wisconsin Statutes]

- (1) On the date a contractor submits a bid to or completes negotiations with a state agency, local governmental unit, or developer, investor or owner on a project subject to Section 66.0903, 66.0904 or 103.49, Wisconsin Statutes, the contractor shall disclose to such state agency, local governmental unit, or developer, investor or owner, the name of any "other construction business", which the contractor, or a shareholder, officer or partner of the contractor, owns or has owned within the preceding three (3) years.
- (2) The term "other construction business" means any business engaged in the erection, construction, remodeling, repairing, demolition, altering or painting and decorating of buildings, structures or facilities. It also means any business engaged in supplying mineral aggregate, or hauling excavated material or spoil as provided by Sections 66.0903(3), 66.0904(2), 103.49(2) and 103.50(2), Wisconsin Statutes.
- (3) This form must **ONLY** be filed, with the state agency project owner, local governmental unit project owner, or developer, investor or owner of a publicly funded private construction project that will be awarding the contract, if **both (A) and (B) are met**.
  - (A) The contractor, or a shareholder, officer or partner of the contractor:
    - (1) Owns at least a 25% interest in the "other construction business", indicated below, on the date the contractor submits a bid or completes negotiations.
    - (2) Or has owned at least a 25% interest in the "other construction business" at any time within the preceding three (3) years.
  - (B) The Wisconsin Department of Workforce Development (DWD) has determined that the "other construction business" has failed to pay the prevailing wage rate or time and one-half the required hourly basic rate of pay, for

### Other Construction Business

Name of Business			
Street Address or P O Box	City	State	Zip Code
Name of Business			
Street Address or P O Box	City	State	Zip Code
Name of Business			
Street Address or P O Box	City	State	Zip Code
Name of Business			
Street Address or P O Box	City	State	Zip Code

**I hereby state under penalty of perjury that the information, contained in this document, is true and accurate according to my knowledge and belief.**

Print the Name of Authorized Officer			
Signature of Authorized Officer	Date Signed		
Name of Corporation, Partnership or Sole Proprietorship			
Street Address or P O Box	City	State	Zip Code

**If you have any questions call (608) 266-6861**

## Prime Contractor Affidavit of Compliance With Prevailing Wage Rate Determination

Authorization for this form is provided under Sections 66.0903(9)(c), 66.0904(7)(c) and 103.49(4r)(c) Wisconsin Statutes.

The use of this form is mandatory. The penalty for failing to complete this form is prescribed in Section 103.005(12), Wisconsin Statutes.

Personal information you provide may be used for secondary purposes [Privacy Law, s. 15.04(1)(m), Wisconsin Statutes].

This form must **ONLY** be filed with the **Awarding Agency** indicated below.

State Of )	Project Name		
	DWD Determination Number	Project Number (if applicable)	
)SS	Date Determination Issued	Date of Contract	
County Of )	Awarding Agency		
	Date Work Completed		

After being duly sworn, the person whose name and signature appears below hereby states under penalty of perjury that

- **I am** the duly authorized officer of the corporation, partnership, sole proprietorship or business indicated below and have recently completed all of the work required under the terms and conditions of a contract with the above-named awarding agency and make this affidavit in accordance with the requirements set forth in Section 66.0903(9)(c), 66.0904(7)(c) or 103.49(4r)(c), Wisconsin Statutes and Chapter DWD 290 of the Wisconsin Administrative Code in order to obtain FINAL PAYMENT from such awarding agency.
- **I have** fully complied with all the wage and hour requirements applicable to this project, including all of the requirements set forth in the prevailing wage rate determination indicated above which was issued for such project by the Department of Workforce Development on the date indicated above.
- **I have** received the required affidavit of compliance from each of my agents and subcontractors that performed work on this project and have listed each of their names and addresses on page 2 of this affidavit.
- **I have** full and accurate records that clearly indicate the name and trade or occupation of every worker(s) that I employed on this project, including an accurate record of the hours worked and actual wages paid to such worker(s).
- **I will** retain the records and affidavit(s) described above and make them available for inspection for a period of at least three (3) years from the completion date indicated above at the address indicated below and shall not remove such records or affidavit(s) without prior notification to the awarding agency indicated above.

Name of Corporation, Partnership, Sole Proprietorship, Business, State Agency or Local Governmental Unit				
Street Address	City	State	Zip Code	Telephone Number
Print Name of Authorized Officer			Date Signed	
Signature of Authorized Officer				

## List of Agents and Subcontractors

Name			Name		
Street Address			Street Address		
City	State	Zip Code	City	State	Zip Code
Telephone Number			Telephone Number		
Name			Name		
Street Address			Street Address		
City	State	Zip Code	City	State	Zip Code
Telephone Number			Telephone Number		
Name			Name		
Street Address			Street Address		
City	State	Zip Code	City	State	Zip Code
Telephone Number			Telephone Number		
Name			Name		
Street Address			Street Address		
City	State	Zip Code	City	State	Zip Code
Telephone Number			Telephone Number		
Name			Name		
Street Address			Street Address		
City	State	Zip Code	City	State	Zip Code
Telephone Number			Telephone Number		
Name			Name		
Street Address			Street Address		
City	State	Zip Code	City	State	Zip Code
Telephone Number			Telephone Number		



## Agent or Subcontractor Affidavit of Compliance With Prevailing Wage Rate Determination

Authorization for this form is provided under Sections 66.0903(9)(b), 66.0904(7)(b) and 103.49(4r)(9b), Wisconsin Statutes. The use of this form is mandatory. The penalty for failing to complete this form is prescribed in Section 103.005(12), Wisconsin Statutes.

Personal information you provide may be used for secondary purposes [Privacy Law, Section 15.04(1)(m), Wisconsin Statutes].

This form must **ONLY** be filed with the **Awarding Contractor** indicated below.

State Of _____ )  )SS  County Of _____ )	Project Name	
	DWD Determination Number	Project Number (if applicable)
	Date Determination Issued	Date of Subcontract
	Awarding Contractor	
	Date Work Completed	

After being duly sworn, the person whose name and signature appears below hereby states under penalty of perjury that

- **I am** the duly authorized officer of the corporation, partnership, sole proprietorship or business indicated below. We have recently completed all of the work required under the terms and conditions of a subcontract with the above-named awarding contractor. We make this affidavit in accordance with the requirements set forth in Section 66.0903(9)(b), 66.0904(7)(b) or 103.49(4r)(b), Wisconsin Statutes and Chapter DWD 290 of the Wisconsin Administrative Code in order to obtain FINAL PAYMENT from such awarding contractor.
- **I have** fully complied with the entire wage and hour requirements applicable to this project, including all of the requirements set forth in the prevailing wage rate determination indicated above which was issued for such project by the Department of Workforce Development on the date indicated above.
- **I have** received the required affidavit of compliance from each of my agents and subcontractors that performed work on this project and have listed each of their names and addresses on page 2 of this affidavit.
- **I have** full and accurate records that clearly indicate the name and trade or occupation of every worker(s) that I employed on this project, including an accurate record of the hours worked and actual wages paid to such worker(s).
- **I will** retain the records and affidavit(s) described above and make them available for inspection for a period of at least three (3) years from the completion date indicated above at the address indicated below and shall not remove such records or affidavit(s) without prior notification to the awarding contractor.

Name of Corporation, Partnership, Sole Proprietorship, Business, State Agency or Local Governmental Unit				
Street Address or PO Box	City	State	Zip Code	Telephone Number (    )
Print Name of Authorized Officer			Date Signed	
Authorized Officer Signature				

## List of Agents and Subcontractors

Name			Name		
Street Address			Street Address		
City	State	Zip Code	City	State	Zip Code
Telephone Number (    )			Telephone Number (    )		
Name			Name		
Street Address			Street Address		
City	State	Zip Code	City	State	Zip Code
Telephone Number (    )			Telephone Number (    )		
Name			Name		
Street Address			Street Address		
City	State	Zip Code	City	State	Zip Code
Telephone Number (    )			Telephone Number (    )		
Name			Name		
Street Address			Street Address		
City	State	Zip Code	City	State	Zip Code
Telephone Number (    )			Telephone Number (    )		
Name			Name		
Street Address			Street Address		
City	State	Zip Code	City	State	Zip Code
Telephone Number (    )			Telephone Number (    )		
Name			Name		
Street Address			Street Address		
City	State	Zip Code	City	State	Zip Code
Telephone Number (    )			Telephone Number (    )		
Name			Name		
Street Address			Street Address		
City	State	Zip Code	City	State	Zip Code
Telephone Number (    )			Telephone Number (    )		

**If you have any questions call (608) 266-6861**

## Request to Employ Subjourneyperson

The use of this form is mandatory. The penalty for failing to complete this form is prescribed in Section 103.005(12), Wisconsin Statutes. Personal information you provide may be used for secondary purposes (Privacy Law, s. 15.04(1)(m), Wisconsin Statutes).

The employer indicated below requests that the Department of Workforce Development (DWD) determine the prevailing wage rate(s) and related qualifications to enable such employer to use a subjourneyperson(s) on the following prevailing wage project, in accordance with the provisions of Section DWD 290.025, Wisconsin Administrative Code.

1. Name of Project Appearing on the Project Determination		
County	City, Village or Town	
DWD Project Determination Number	Project Number (if applicable)	
2. Job Classification(s) for which you request a subjourney rate (i.e., carpenter, electrician, plumber, etc.)		
a.	b.	
c.	d.	
3. Employer Name (Print)		
Address	City	State
Telephone Number (       )	Requester Title	
Email address (if you prefer to receive your response via email)	Fax Number (if you prefer to receive your response via fax) (       )	

**READ CAREFULLY:** I understand that this request is ONLY applicable to the project and job classification(s) listed above and that subjourney employees primarily work under the direction of and assist a skilled trade employee by frequently using the tools of a skilled trade and will NOT regularly perform the duties of a general laborer, heavy equipment operator or truck driver. If the subjourney employee regularly performs the work of a different trade or occupation, he/she will be compensated for such work at the applicable journeyperson prevailing wage rate. I agree to compensate subjourney employees in strict accordance with the directions received from the DWD.

Requester Signature	Date Signed
---------------------	-------------

MAIL the completed request to:  
 EQUAL RIGHTS DIVISION, LABOR STANDARDS BUREAU  
 PO BOX 8928, MADISON WI 53708  
**OR**  
 FAX the completed request to: (608) 267-0310 / **DO NOT e-mail your request.**  
 Call (608) 266-6861 for assistance in completing this form.

Department of Workforce Development  
Equal Rights Division  
P.O. Box 8928  
Madison, WI 53708-8928  
Telephone: (608) 266-6860  
Fax: (608) 267-4592  
TTY: (608) 264-8752



Scott Walker, Governor  
Reginald J. Newson, Secretary  
John P. Conway, Division Administrator

## PREVAILING WAGE – Public Entity Project Owners

Any public works project that has a total estimated project cost that equals or exceeds single-trade or multiple-trade project thresholds requires a prevailing wage rate determination issued by the Department of Workforce Development (DWD). Public works include erecting, constructing, remodeling, repairing, demolishing, alterations, painting and decorating projects for a local governmental unit or state agency. State law excludes minor service or maintenance work, warranty work, or work under a supply-and-installation contract. There is a statutory definition for each of these exclusions. The prevailing wage law that applies to local governmental units is §66.0903, Wis. Stats. The prevailing wage law that applies to state agencies is §103.49, Wis. Stats. The applicable administrative rules for all public entities are DWD 290 and DWD 294, Wis. Adm. Code.

### Thresholds

A "single-trade project of public works" means a project in which a single trade accounts for 85% or more of the total labor cost of the project. The single trade threshold is \$48,000.

A "multiple-trade project of public works" means a project in which no single trade accounts for 85% or more of the total labor cost of the project.

(a) The multiple-trade threshold is \$100,000, unless a municipality falls under the description in (b).

(b) The multiple-trade threshold of \$234,000 applies to public works projects erected, constructed, repaired, remodeled, or demolished by a private contractor for •a city or village with a population less than 2500 or •a town.

Effective July 1, 2011, a local governmental unit or state agency that has a public works project that equals or exceeds the prevailing wage thresholds must do all of the following:

- Request a prevailing wage rate determination for the project from DWD at least 30 days before soliciting bids or negotiating contracts. An Application for Prevailing Wage Rate Determination is available on the DWD website: [http://dwd.wisconsin.gov/er/prevailing\\_wage\\_rate/default.htm](http://dwd.wisconsin.gov/er/prevailing_wage_rate/default.htm)

To avoid waiting for a project determination use the on-line application system that permits the user to generate a determination immediately and save all documents in PDF form to the user's computer. Use this project determination on line application at the following address:

[http://dwd.wisconsin.gov/er/prevaling\\_wage\\_rate/pw\\_online\\_determinations.htm](http://dwd.wisconsin.gov/er/prevaling_wage_rate/pw_online_determinations.htm)

- Tell potential contractors the project is subject to state prevailing wage law when soliciting bids.
- Include the prevailing wage rate determination in the construction contract, or if there is no written contract, provide a copy of the project determination to each prime contractor.
- Award contracts to contractors who do *not* appear on the “Consolidated List of Debarred Contractors.”
- Post the prevailing wage rate determination on the project site. (This document is often referred to as “the white sheet.”)
- Notify project contractors that if DWD finds that a contractor violated the prevailing wage law, DWD will assess liquidated damages of 100% of the wages owed to employees.
- Obtain an Affidavit of Compliance from each prime contractor before making final payment for the project.

If the total estimated cost of the project exceeds the prevailing wage thresholds, a local governmental unit or state agency also must obtain a prevailing wage rate determination under the following circumstances:

- when a completed facility is leased, purchased, lease-purchased or otherwise acquired by or dedicated to a public entity in lieu of the public entity contracting for the project,
- when one public entity does work for another public entity,
- when a *private* entity will construct a road, street, bridge, sanitary sewer or water main project and dedicate it to a local governmental unit or the state for its ownership or maintenance (except for some residential subdivisions).

For more information, visit the prevailing wage website: [http://dwd.wisconsin.gov/er/prevaling\\_wage\\_rate/default.htm](http://dwd.wisconsin.gov/er/prevaling_wage_rate/default.htm). For further assistance, call the Equal Rights Division at 608-266-6861 and ask for prevailing wage.

---

## PREVAILING WAGE – Contractors

Any public works project that has a total estimated project cost that equals or exceeds prevailing wage project thresholds requires a prevailing wage rate determination issued by the Department of Workforce Development (DWD). Public works include erecting, constructing, remodeling, repairing, demolishing, alterations, painting and decorating projects for a local governmental unit or state agency. State law excludes minor service or maintenance work, warranty work, or work under a supply-and-installation contract. There is a statutory definition for each of these exclusions. The prevailing wage law that applies to local governmental units and their contractors is §66.0903, Wis. Stats. The prevailing wage law that applies to state agencies and their contractors is §103.49, Wis. Stats. The applicable administrative rules for all prevailing wage projects are DWD 290 and DWD 294, Wis. Adm. Code. These laws include provisions that apply to all contractors and subcontractors working on prevailing wage projects.

Effective July 1, 2011, any contractor or subcontractor working on a local governmental unit or state agency's public works project that equals or exceeds current prevailing wage project thresholds must do all of the following:

- Receive and review the project's prevailing wage rate determination (i.e., white sheet).
- Tell subcontractors the project is subject to state prevailing wage law and include the prevailing wage rate determination in the construction contract, or if there is no written contract, provide a copy of the project determination to each subcontractor.
- Hire subcontractors who do *not* appear on the "Consolidated List of Debarred Contractors."
- Notify subcontractors that if DWD finds that a contractor or subcontractor violated the prevailing wage law, DWD will assess liquidated damages of 100% of the wages owed to employees.

- Apply to DWD for subjourney wage rates prior to employing these individuals on the project.
- Receive and retain a completed Affidavit of Compliance from each subcontractor brought on to the project before providing final payment to those subcontractors.
- Submit a completed Affidavit of Compliance to the contractor who brought the subcontractor on to the project before receiving final payment for the project.
- Maintain payroll records for 3 years that comply with §§66.0903(10)(a) or 103.49(5)(a), Stats. and DWD 274.06.
- Respond to requests from DWD or the project owner to provide payroll records and/or respond to prevailing wage complaints filed by employees or third parties.

For more information, visit the prevailing wage website: [http://dwd.wisconsin.gov/er/prevailing\\_wage\\_rate/default.htm](http://dwd.wisconsin.gov/er/prevailing_wage_rate/default.htm). For further assistance, call the Equal Rights Division at 608-266-6861 and ask for prevailing wage.

## SUMMARY OF PREVAILING WAGE LAW CHANGES EFFECTIVE JULY 1, 2011

(This document updated 07/27/11)

For further updates on this topic, refer to the prevailing wage website at:  
[http://dwd.wisconsin.gov/er/prevailing\\_wage\\_rate/default.htm](http://dwd.wisconsin.gov/er/prevailing_wage_rate/default.htm)

The recently approved State budget bill (2011 Wisconsin Act 40) includes major changes to prevailing wage laws (§§66.0903, 66.0904, 103.49 & 103.50, Wis. Stats.) effective JULY 1, 2011. Significant changes are described below.

Topic	Who's affected?	Brief description of requirement under §66.0903 or §103.49
Thresholds	All public entities & Contractors	The \$25,000 threshold for public works projects has been changed to single-trade and multiple-trade project thresholds as noted below. The new thresholds apply to prevailing wage projects whose prime contract is awarded after June 30, 2011.
Non-applicability: Threshold for Single-Trade Projects	All public entities & Contractors	Any single-trade project of public works with an estimated cost of completion of less than \$48,000 does not require a prevailing wage rate determination. "Single-trade project of public works" means a project of public works in which a single trade accounts for 85 percent or more of the total labor cost of the project.
Non-applicability: Threshold for Multiple-Trade Projects	All public entities except cities, towns & villages as noted below & Contractors	Any multiple-trade project of public works with an estimated cost of completion of less than \$100,000 does not require a prevailing wage rate determination. "Multiple-trade project of public works" means a project of public works in which no single trade accounts for 85 percent or more of the total labor cost of the project.
Non-applicability: Threshold for Multiple-Trade Projects	Cities or villages with a population less than 2500 & Towns & Contractors	A multiple trade project of public works erected, constructed, repaired, remodeled, or demolished by a private contractor for a city or village with a population less than 2500, or a town with an estimated cost of completion of less than \$234,000 does not require a prevailing wage rate determination. "Multiple-trade project of public works" means a project of public works in which no single trade accounts for 85 percent or more of the total labor cost of the project.
Non-applicability: Minor service & maintenance work	Towns & Contractors	The following TOWN projects only do not require a prevailing wage rate determination: <ul style="list-style-type: none"> <li>• A project not funded under §86.31, Stats. (TRIP projects) that is limited to minor crack filling, chip or slurry sealing or other minor pavement patching, not including overlays.</li> <li>• The depositing of gravel on an existing gravel road applied solely to maintain the road;</li> <li>• Road shoulder maintenance;</li> <li>• Cleaning drainage or sewer ditches or structures;</li> <li>• Any other limited, minor work on public facilities or equipment that is routinely performed to prevent breakdown or deterioration.</li> </ul>
Non-applicability: Work which a contractor or individual donates to a public entity	All public entities	Prevailing wage laws §§66.0903 & 103.49, Stats., do not apply to work performed on a project of public works for which the local governmental unit or the state or the state agency contracting for the project is not required to compensate any contractor, subcontractor, contractor's or subcontractor's agent, or individual for performing the work.



Topic	Who's affected?	Brief description of requirement under §66.0903 or §103.49
Non-applicability: Residential	All public entities	A prevailing wage rate determination is not required for the erection, construction, repair, remodeling, or demolition of a residential property containing 2 dwelling units or less.
Non-applicability: Residential subdivision infrastructure	All public entities	A prevailing wage rate determination is not required for a road, street, bridge, sanitary sewer, or water main project that is a part of a development in which at least 90 percent of the lots contain or will contain 2 dwelling units or less, as determined by the local governmental unit at the time of approval of the development, and that, on completion, is acquired by, or dedicated to, a local governmental unit (including under §236.13(2), Stats.), or the state, for ownership or maintenance by the local governmental unit or the state.
Non-applicability: Certain nursing homes	All public entities	Prevailing wage law §66.0903, Stats., does not apply to a project of public works involving the erection, construction, repair, remodeling, or demolition of a nursing home in a county having a population of less than 50,000 when the project commences no later than July 1, 2012.
Electronic certified payroll record	Contractors	The requirement that every contractor on a prevailing wage project submit to DWD monthly a certified record of employees who worked on the project and that DWD post these certified records on its Internet website is discontinued effective July 1, 2011. However, contractors who worked on prevailing wage projects during the period January 1, 2010 through June 30, 2011, must comply with the repealed law for work completed on projects during that period of time.
Payroll record inspection request by any person	Contractors & Complainants	Any person may request DWD to inspect the payroll records of any contractor working on a prevailing wage project. On receipt of such a request, the contractor must submit to DWD a certified record of its payroll records, other than personally identifiable information relating to an employee of the contractor, for no longer than a 4-week period. DWD may request records from a contractor under this provision no more than once per calendar quarter for each project of public works on which the contractor is performing work. The department may not charge a requester a fee for obtaining that information. DWD must make these certified records available for public inspection.
Complaints	Complainants	There are no longer investigation fees.
Statewide uniformity	Local governmental units	A local governmental unit may not enact & administer a prevailing wage ordinance/provision for public works or publicly funded private construction projects. Any extant laws to that effect are void.

Topic	Who's affected?	Brief description of requirement under §66.0903, §103.49 or §103.50
Covered employees	Truck drivers & Other workers & Contractors	<p>A laborer, worker, mechanic, or truck driver who is employed to process, manufacture, pick up, or deliver materials or products from a commercial establishment that has a fixed place of business from which the establishment supplies processed or manufactured materials or products or from a facility that is not dedicated exclusively, or nearly so, to a project of public works is NOT entitled to receive the prevailing wage rate UNLESS any of the following applies:</p> <ol style="list-style-type: none"> <li>1) the laborer, worker, mechanic, or truck driver is employed to go to the source of mineral aggregate such as sand, gravel, or stone and deliver that mineral aggregate to the site of a project of public works by depositing the material directly in final place, from the transporting vehicle or through spreaders from the transporting vehicle.</li> <li>2) the laborer, worker, mechanic, or truck driver is employed to go to the site of a project of public works, pick up excavated material or spoil from the site of the project, and transport that excavated material or spoil away from the site of the project.</li> </ol>
Annual Prevailing Wage Survey	All public entities	When establishing yearly prevailing wage rates, DWD may not use data from any construction work that is performed by a local governmental unit or a state agency.
Prevailing Wage Rates	DOT & Contractors & Employees	For state highway prevailing wage rates, DWD is required to include wage rates for work performed on Sundays, holidays and shift differentials based on the time of day or night when work is performed.
<p>The 2009-2011 State budget bill (2009 Wisconsin Act 28) created a new prevailing wage law (§66.0904, Wis. Stats.) for PUBLICLY FUNDED PRIVATE CONSTRUCTION PROJECTS effective January 1, 2010. The current 2011-2013 State budget bill (2011 Wisconsin Act 32) REPEALS this law. So the publicly funded private construction projects law only applies to projects that awarded the prime contract during the period January 1, 2010 through June 30, 2011.</p>		

**SINGLE & MULTIPLE TRADE PROJECT THRESHOLDS  
FOR §§66.0903 & 103.49, Wis. Stats.  
Effective July 1, 2011**

The \$25,000 threshold for public works projects has been changed to single-trade and multiple-trade project thresholds as described below. Projects of public works with total estimated costs of completion that equal or exceed these thresholds require a prevailing wage rate determination.

**SINGLE-TRADE THRESHOLD**

A “single-trade project of public works” means a project in which a single trade accounts for 85 percent or more of the total labor cost of the project.

The single trade threshold is \$48,000.

**MULTIPLE-TRADE THRESHOLDS**

A “multiple-trade project of public works” means a project in which no single trade accounts for 85 percent or more of the total labor cost of the project.

(a) The multiple-trade threshold is \$100,000, unless a municipality falls under the description in (b).

(b) The multiple-trade threshold of \$234,000 applies to public works projects erected, constructed, repaired, remodeled, or demolished by a private contractor for:

- a city or village with a population less than 2500, or
- a town

**APPLYING THE NEW THRESHOLDS**

The department will apply the new single-trade & multiple-trade prevailing wage thresholds to projects of public works for which the prime contract is awarded on or after July 1, 2011.

SECTION 01 00 00  
BASIC REQUIREMENTS

PART 1 GENERAL

1.1 SECTION SUMMARY

- A. Section Includes:
1. Section Summary
  2. Summary of the Work
  3. Contractor Use of Premises
  4. Applications for Payment
  5. Coordination
  6. Conferences
  7. Progress Meetings
  8. Shop Drawings
  9. Quality Assurance / Quality Control of Installation
  10. References
  11. Parking
  12. Staging Areas
  13. Occupancy During Construction and Conduct of Work
  14. Protection
  15. Progress Cleaning
  16. Products
  17. Transportation, Handling, Storage and Protection
  18. Contract Closeout Procedures
  19. Final Cleaning

1.2 SUMMARY OF THE WORK

- A. Project Description: Contractor shall complete the work as described in Scope of Work for whichever option is contracted.
- B. Work by Owner: Owner shall complete all work which Owner is responsible for as described in Scope of Work for whichever option is contracted for.
- C. Permits: Prior to commencement of the Work, Dane County shall secure Conditional Use Permit and erosion control permit. Contractor to secure any and all other necessary permits for completion of the Work.

1.3 CONTRACTOR USE OF PREMISES

- A. Limit use of premises to allow work by others and work by Owner.

#### 1.4 APPLICATIONS FOR PAYMENT

- A. Submit two (2) copies of each application on AIA G702™ and G703™ forms or approved contractors invoice form.
- B. Content and Format: Utilize Schedule of Values for listing items in Application for Payment.
- C. Payment Period: Monthly.

#### 1.5 COORDINATION

- A. Coordinate scheduling, submittals, and work of various sections of Specifications to assure efficient and orderly sequence of installation of interdependent construction elements.
- B. Verify utility requirement characteristics of operating equipment are compatible with building utilities.
- C. Coordinate space requirements with Dane County as applies to work on the excavation site and stockpiling at the adjacent site and at the Rodefild Landfill.

#### 1.6 CONFERENCES

- A. Dane County Department Public Works, Highway & Transportation will schedule a preconstruction conference after Award of Contract for all affected parties.
- B. Convene a pre-construction conference at project site prior to commencing work of the section.

#### 1.7 PROGRESS MEETINGS

- A. Owner shall preside at meetings, record minutes, and distribute copies within two (2) days to those affected by decisions made.

#### 1.8 SHOP DRAWINGS

- A. Submit number of copies that Contractor requires, plus two (2) copies that shall be retained by Public Works Project Engineer.

#### 1.9 QUALITY ASSURANCE / QUALITY CONTROL

- A. Comply with specified standards as minimum quality for the Work except when more stringent tolerances, codes, or specified requirements indicate higher standards or more precise workmanship.

#### 1.10 REFERENCES

- A. Conform to reference standard by date of issue current as of date for receiving bids.

- B. Should specified reference standard conflict with Construction Documents, request clarification from Public Works Project Engineer before proceeding.

#### 1.11 PARKING

- A. Arrange for temporary parking areas to accommodate construction personnel. Parking shall be available at the Work site.

#### 1.12 STAGING AREAS

- A. Coordinate staging areas with Public Works Project Engineer prior to starting the Work.
- B. Each Contractor shall be responsible for safety of equipment and materials that are stored on site.

#### 1.13 OCCUPANCY DURING CONSTRUCTION AND CONDUCT OF WORK

- A. Areas of adjacent facility will be occupied during period when the Work is in progress. Work may be done during normal business hours (7:30 am to 4:00 pm), but confer with Owner, schedule work and store materials so as to interfere as little as possible with normal use of premises.
- B. Work shall be done and temporary facilities furnished so as not to interfere with access to any occupied area and so as to cause least possible interference with normal operation of facility or any essential service thereof.
- C. Contractor shall, at all times, provide approved, facility entrances for use by Owner, and employees.
- D. Contractor shall provide adequate protection for all parts of facility, its contents and occupants wherever the Work under this contract is to be performed.
- E. Each Contractor shall arrange with Owner to make necessary alterations, do new work, make connections to all utilities, etc., at such times as will not cause interruption of utility services to facility. Contractor doing this work shall protect, cap, cut off and / or replace and relocate existing pipes, electrical work and other active utilities encountered which may interfere with new construction work.
- F. New work in extension of existing work shall correspond in all respects with that to which it connects or similar existing work unless otherwise indicated or specified.
  - 1. Existing work shall be cut, altered, removed or replaced as necessary for performance of contract obligations.
  - 2. Work remaining in place, damaged or defaced by reason of work done under this contract shall be restored equal to its condition at time of Award of Contract.
  - 3. If removal of work exposes discolored or unfinished surfaces or work out of alignment, such surfaces shall be refinished or materials replaced as necessary to make continuous work uniform and harmonious.

#### 1.14 PROTECTION

- A. Contractor shall protect from injury all trees, shrubs, hedges, walks and driveways and pay for any damage to same resulting from insufficient or improper protection.
- B. Guard Light: Contractor shall provide and maintain guard lights at all barricades, railings, obstructions in streets, roads or sidewalks and at all trenches adjacent to public walks or roads.

#### 1.15 PROGRESS CLEANING

- A. Maintain areas free of waste materials, debris, and rubbish. Maintain site in clean and orderly condition.

#### 1.16 PRODUCTS

- A. Products: Means new material, machinery, components, equipment, fixtures, and systems forming the Work, but does not include machinery and equipment used for preparation, fabrication, conveying and erection of the Work. Products may also include existing materials or components specifically identified for reuse.
- B. Do not use materials and equipment removed from existing premises, except as specifically identified or allowed by Construction Documents.

#### 1.17 TRANSPORTATION, HANDLING, STORAGE AND PROTECTION

- A. Transport, handle, store and protect Products in accordance with manufacturer's instructions.

#### 1.18 CONTRACT CLOSEOUT PROCEDURES

- A. Submit written certification that Construction Documents have been reviewed, the Work has been inspected, and the Work is complete in accordance with Construction Documents and ready for Public Works Project Engineer's inspection.
- B. Submit final Application for Payment identifying total adjusted Contract Sum / Price, previous payments, and amount remaining due.

#### 1.19 FINAL CLEANING

- A. Execute final cleaning prior to final inspection.
- B. Remove waste and surplus materials, rubbish, and construction facilities from site.

### PART 2 PRODUCTS

Not Used.

PART 3 EXECUTION

Not Used.

END OF SECTION



SECTION 02 55 00

EROSION CONTROL

PART 1 GENERAL

1.1 SUMMARY

- A. Section Includes:
  - 1. Straw Bale Barriers
  - 2. Sediment Control Fences
  - 3. Erosion Mat
  - 4. Asphaltic Materials
  - 5. Staples
  - 6. Riprap
  - 7. Stakes
  - 8. Temporary Use of Permanent Features
  - 9. Approvals
  
- B. Related Sections:
  - 1. Applicable provisions of Division 1 shall govern work in this Section.

1.2 REFERENCES

- A. "State of Wisconsin Construction Site Best Management Practice Handbook", Publication WR-222-89.
  - 1. Copies are available by contacting the following:  
State of Wisconsin Department of Natural Resources  
Non-Point Service and Land Management Section  
101 S. Webster Street / POB 7921  
Madison, WI 53707-7921  
\* or \*  
Document Sales and Distribution  
202 South Thornton Avenue / POB 7840  
Madison, WI 53707  
608/266-3358
  
- B. "State of Wisconsin, Department of Transportation, Division of Highways Standard Specifications for Road and Bridge Construction" (SSRBC), current edition.
  - 1. Wherever DOT or SSRBC appears in this Specification it refers to current edition, except that this contract shall be a lump sum contract and items, method of measurement and basis of payment shall not apply.
  
- C. State of Wisconsin Building Code: Chapter 65 - Construction Site Erosion Control.
  
- D. COMM 65.20 Design Requirements (-1999-65-7-)

### 1.3 DESCRIPTION OF WORK

- A. Work under this Section shall consist of providing all work, materials, labor, equipment, and supervision to provide and construct erosion control measures necessary to prevent runoff, tracking, or loss of soil materials by water or mechanical action from disturbed portions of project site as provided for in these Specifications and Drawings and as determined by Public Works Project Engineer.
- B. Contractor's attention is specifically directed to Article 30 of the General Requirements pertaining to Stormwater Management and Erosion Control.
- C. This Specification shall apply to all areas of work on this project, unless otherwise specified.
- D. All work shall be in accordance with applicable manufacturer's instructions, and all local, state and federal codes, regulations, laws, and ordinances.
- E. Contractor shall follow COMM 65.08 General Plan Requirements (-1999-65-5-).
- F. Contractor shall comply with applicable requirements of Section 404 of Clean Water Act and Navigable Waters Protection (Chapters 30 & 31).
- G. Contractor shall submit Construction Site Erosion Control Plan and meet Shoreland and Wetland Zoning requirements as required by Building Inspection Offices for cities and villages, Dane County Land Regulations, and Records Department for townships.
- H. Contractor shall apply for NPDES Stormwater Permit for Erosion Control from Wisconsin Department of Natural Resources if project work disrupts more than 5 acres. Contractor shall comply with any requirements of said permit. Smaller sites that are part of a planned development larger than 5 acres must also apply for a permit.

### 1.4 SUBMITTALS

- A. Contractor shall submit 5 copies of erosion control plans to Public Works Project Engineer for review and approval prior to commencement of any site work.

### 1.5 RELATED WORK

- A. Site Preparation.
- B. Clearing & Grubbing.
- C. Earthwork.
- D. Grading.
- E. Excavation & Trenching.
- F. Site Restoration.

- G. Seeding & Sodding.
- H. Substitutions shall not change contract price established at bid opening.

## PART 2 PRODUCTS

### 2.1 STRAW BALE BARRIERS

- A. Bales used for erosion control shall be either hay or straw, shall have rectangular surfaces, and shall be tightly bound with twine, not wire.

### 2.2 SEDIMENT CONTROL FENCES

- A. Sediment control fences (also called silt fences) shall comply with requirements of SSRBC 628.2.9.1 and shall be equal to that of Mirafi 100, Trevira Spunbond 1115, Amoco 1380, or Supac 5NP, backed by industrial polypropylene netting or 18 gauge woven wire fence. Fabric shall come in rolls of 3 foot width. Posts used to support fabric shall be at least 2" x 2" nominal in cross section and of sufficient length to fully support 36 inch high fence.

### 2.3 EROSION MAT

- A. Jute Fabric: shall conform to SSRBC Section 628.2.1.
- B. Wood Fiber Blanket: shall conform to SSRBC Section 628.2.2.
- C. Fiber Glass Roving: shall conform to SSRBC Section 628.2.3.

### 2.4 ASPHALTIC MATERIALS

- A. Asphaltic Materials intended for anchoring fiberglass roving materials shall conform to SSRBC Section 628.2.4.

### 2.5 STAPLES

- A. Staples intended to anchor erosion mat shall conform to SSRBC 628.2.5 and shall be U-shaped, made of No. 11 gage or heavier steel wire, or other approved materials, have width of one to two inches, and length of not less than 6 inches for firm soils and not less than 12 inches for loose soils.

### 2.6 RIPRAP

- A. Materials used in riprap shall meet requirements for the class of materials named and shall conform to SSRBC Section 606 except that riprap work under these Specifications shall be placed on filter bed of not less than 6 inches of granular material with geotextile filter fabric liner.

## 2.7 STAKES

- A. Stakes intended to anchor erosion mat shall be pieces of plasterer's lath or stakes equivalent thereto, 12 inches in length. Stakes intended for use in straw bale barriers shall be 2" x 2" x 30" nominal driven flush with top of bale. Stakes for anchoring sodding or erosion mat shall be driven so that longitudinal width is parallel with direction of surface water flows.

## 2.8 TEMPORARY USE OF PERMANENT FEATURES

- A. When Contract contains items of work, which are of erosion control or stormwater nature, and are intended to be of permanent installation, Contractor may employ these items in control of erosion and stormwater during construction activities. However, these items shall be fully cleaned, restored, and in every way fully functioning for its intended permanent use prior to acceptance of the Work.

## 2.9 APPROVALS

- A. All materials shall be subject to Public Works Project Engineer's approval.

## PART 3 EXECUTION

### 3.1 GENERAL

- A. Contractor shall consider control of erosion, and requirements and methods of these Specifications as standard requirements for all work conducted under this Contract by employees, subcontractors, suppliers, and others having purpose on construction site.
- B. All work shall be in accordance with manufacturer's instruction where these Specifications do not specify higher requirement.
- C. Contractor shall undertake any and all measures required in Contract or shown on Drawings, or determined necessary by Contractor, or as ordered by Public Works Project Engineer to protect all adjacent lands, and all ground and surface waters from contamination by direct and indirect migration of sands, silts, mud, debris, chemicals and other such pollutants from jobsite through use of specified materials. Such measures shall include, but not be limited by enumeration to:
  - 1. Construction and maintenance of sedimentation basins, or use of sedimentation vessels.
  - 2. Construction and maintenance of erosion control barriers.
  - 3. Construction and maintenance of erosion mats.
  - 4. Construction and maintenance of surface runoff diversion channels around construction site.
  - 5. Construction and maintenance of temporary and permanent drainage structures and facilities.
  - 6. Sweeping, shoveling, and other removal of materials from streets and other paved surfaces by hand and / or mechanical methods (but not flushing).
  - 7. Removal of silts, sediments, and debris that have left the jobsite due to erosion.

8. Restoration of lands and waters subject to damage by erosion from jobsite.

### 3.2 REQUIRED EROSION CONTROL MEASURES

#### A. Permits and Approvals

1. All permits and approvals required for land disturbance activities (including DNR permits for dewatering systems discharging more than 70 GPM) shall be approved and received prior to commencement of land disturbing activities. Contractor shall fully comply with all such permit and approval requirements and shall retain a copy of approvals and / or approved permits on jobsite at all times of construction activity.

#### B. Grading and Earthwork Measures

1. All erosion control measures shall follow COMM 65.21 General Installation Requirements (-1999-65-9-).
2. All temporary or permanent erosion control measures shall be installed prior to any on site grading or land disturbances.
3. Stripping of vegetation, grading, excavation, or other land disturbing activities shall be done in logical sequence and manner that will minimize erosion. If possible, construction shall be scheduled for times of year when erosion hazards are minimal. Natural vegetation shall be retained and protected in all areas not designated for improvements or earthwork.
4. Any soil or dirt piles which will remain in existence for more than 7 consecutive days, whether to be worked during that period or not, shall not be located within 25 feet of any roadway, parking lot, paved area, or drainage structure or channel (unless intended to be used as part of erosion control measures). Temporary stabilization and control measures (seeding, mulching, tarping, erosion matting, barrier fencing, etc.) are required for protection of disturbed areas and soil piles which will remain unworked for a period of more than 14 consecutive calendar days.

#### C. Drainage Measures

1. Drainage provisions shall be designed to contain increased runoff resulting from development of site and / or disturbances to natural vegetative cover, during and after construction activity. Drainage shall be conveyed to nearest adequate public facility. Water may not be discharged in manner that will cause erosion or sedimentation of site or receiving facility.
2. Drain inlets shall be protected with erosion control barriers of straw or hay bales, silt fencing, filter baskets, or other equivalent methods approved by Public Works Project Engineer that provide necessary erosion protection.
3. Roof drainage and runoff from all areas upslope of site shall be diverted around areas to be disturbed or channeled through site in manner which will not cause erosion.
4. Water runoff shall be minimized and retained on-site wherever possible to promote percolation of surface water. Water may not be discharged in manner that will cause erosion or sedimentation of site or receiving facility.
5. Site dewatering shall be undertaken in manner to minimize pumping of sediments and discharged to sedimentation basin or sedimentation vessel in manner to minimize discharge of sediments.

- D. Tracking and Sedimentation Control Measures
1. Each site shall provide measures per COMM 65.21 (7) - Soil Tracking, to prevent tracking of sediment from site onto public or private roadways, parking lots, and paved areas. Such measures shall include:
    - a. Prohibiting construction activities that are off of paved, graveled, or stabilized surfaces during periods of precipitation and wet soils.
    - b. Each site shall have adequate access drives and parking areas of sufficient width, length, and wearing surface.
    - c. Access roads and parking areas receiving more than 5 vehicle trips per hour shall be graveled or paved.
    - d. Access roads receiving more than 15 vehicle trips per hour shall be equipped with graveled or paved areas of adequate size and surface for removal of dirt, mud, sediments, and other debris by sweeping, washing, or other methods before vehicle enters adjacent roadways, parking areas, or paved surfaces.
    - e. Wash water shall be discharged to sedimentation basins, sedimentation vessels, or other such control areas.

### 3.3 MAINTENANCE

- A. Contractor shall inspect all erosion control measures within 24 hours of end of each rainfall event, or daily during period of prolonged rainfall, or weekly during periods without rainfall. Contractor shall immediately repair and / or replace any and all damaged, failed, or inadequate erosion control measures.

### 3.4 CLEANING AND DISPOSAL

- A. Surplus excavation materials shall be removed from site immediately after rough grading. Disposal site for surplus excavation materials shall also be subject to these erosion control requirements.
- B. Any sediment reaching a public or private roadway, parking lot, sidewalk, or other paved area and which constitutes a hazard to traffic or which may be further scattered by traffic, shall be immediately and completely removed by scraping, sweeping, shoveling or other such method (except flushing). Any accumulations not requiring immediate attention shall be completely removed at least once at end of each workday.
- C. Sediment cleanup shall follow COMM 65.22 (2):
1. Mechanical erosion control measures shall be cleared of sediment by time accumulation reaches 50% of height of control measure.
  2. Offsite sediment deposition occurring as result of storm event shall be cleaned up within 24 hours after end of storm event.
  3. All other offsite sediment deposition occurring as result of construction activities shall be cleaned up by end of same workday.
- D. All waste and unused construction materials shall be disposed of frequently and in licensed solid waste or wastewater facilities. No garbage, debris, cleaning wastes, toxic materials, or hazardous materials shall be buried on the site, dumped on the land surface

or in detention basins, or discharged or otherwise allowed to be carried off site by runoff onto adjacent lands or into receiving waters or storm sewer systems.

END OF SECTION

## DEFINITIONS

Contractor	Contractor is person, firm, or corporation with whom County makes Contract. Though multiple contracts may be involved, Construction Documents treat them throughout as if each were of singular number.
Owner	Refers to Dane County.
WDNR	Wisconsin Department of Natural Resources
Work	Includes all labor, equipment and materials necessary to produce project required by Construction Documents and Scope of Work section.
Excavation Site	The area from which clay is to be excavated and extracted. The proposed site location is within the area highlighted in Appendix A. Appendix B includes drawing showing the layout of the site, an isopach of the clay on the site, an erosion control plan, and rough grading plan for the site for after completion.
Rodefild Stockpile	Site within the Rodefild Landfill Site where clay is to be stockpiled. The Rodefild Landfill Site is located at 7102 U.S. Highway 12 & 18, Madison, WI. The stockpile location within the site is shown on the site map included as Appendix C. Owner is responsible for maintenance and erosion control of this stockpile.



## SCOPE OF WORK

Dane County seeks to stockpile clay at the Rodefeld Landfill site for use in construction of a new landfill cell.

### BID OPTIONS AND AWARD

This bid proposal contains three options for Work. Bidders may submit bids for one, two, or all three of the options.

The County will award the bid to the responsive and responsible bidder whose bid is most advantageous to the County. Dane County reserves the right to accept any part of this bid deemed to be in the best interest of the County. The County also retains the right to accept or reject any or all bids.

### **Option A: Trucking Only**

Contractor shall be responsible for hauling 78,000 tons of clay from the Excavation Site and depositing it at the Rodefeld Stockpile. Contractor shall be responsible solely for the hauling of the clay. Tonnage of clay shall be measured by Owner at the Scale House at the Rodefeld Landfill Site (exact location of which is shown in Appendix B). Payment shall be made based on tonnage of clay received. The hours of operation of the Excavation Site will be 8:00 am – 4:00 pm, Monday through Friday. Rodefeld Landfill is open to receive clay Monday through Friday, 7:00 am - 5:00pm. The contractor will be responsible for delivering a minimum of 1,500 tons per day on average during these hours of operation. Work is expected to be completed by the following schedule:

Anticipated contract award - April 1, 2014  
Deliver at least 39,000 tons of clay by June 16, 2014  
Deliver 78,000 tons of clay by July 7, 2014

Owner shall be responsible for excavating the clay, loading Contractor's trucks, and providing a site road to the excavation site as well as erosion control, maintenance, and management of the stockpile and erosion control, grading, and seeding and mulching of the Excavation Site. Option A Base Bid shall be for hauling 78,000 tons of clay.

Owner will obtain all necessary permissions for trucks hauling from the Excavation Site. The following haul route must be used: Exit the borrow site toward the north and travel west on Easy Street for approximately ½ miles to the junction with County Trunk Highway I. Turn right and travel north on CTH I for approximately 3 miles to the junction with CTH V. Turn right and travel east on CTH V for approximately 1.2 miles to the junction with I-39/90/94. The interstate will then be followed south and east to the junction with USH 12-18 which will be taken east to the landfill. The total haul distance is approximately 24 miles. No route access restrictions are anticipated other than possible weight restrictions in early Spring on Easy Street. Contractor is responsible for having all necessary licenses and permits for trucks used by the Contractor for this work.

**Option A Alternate (optional)** is for hauling additional clay up to a total of 180,000 tons. If bidder includes unit pricing for hauling beyond 78,000 tons, Owner may exercise the option for additional hauling up to 102,000 additional tons at its discretion. Hauling beyond the base price quantity of 78,000 tons shall be coordinated with Contractor. Work is expected to be completed by the following schedule:

Anticipated contract award - April 1, 2014  
Deliver at least 39,000 tons of clay by June 16, 2014  
Deliver 78,000 tons of clay by July 7, 2014  
Deliver up to 180,000 tons of clay by September 30, 2014.

## **Option B: Excavation and trucking**

Contractor shall be responsible for excavating 78,000 tons of clay from the Westport location and hauling and depositing it at the Rodefled Stockpile. Contractor shall coordinate with Owner. Contractor shall be responsible for clay excavation, installation and maintenance of erosion control, site work, and restoration of impacted areas at the Excavation Site per drawings shown in Appendix A. Contractor shall be responsible for construction of the site entrance/exit and all other civil site work necessary to complete the Work. Refer to Appendix A for an isopach of the clay on site, erosion control plan for the Work, and layout of the site. Only clay from areas of the excavation site where clay is 2 feet thick or thicker per the provided isopach shall be excavated and delivered to the Rodefled Stockpile. Clay that is excavated and delivered to the Rodefled Stockpile shall not be comingled or contaminated with other soil types. Areas of the site impacted by the Work shall be restored and seeded per the grading plan and notes in Appendix A.

Contractor shall be responsible for hauling excavated clay to the Rodefled Stockpile. Owner shall be responsible for maintenance of the Rodefled Stockpile and the necessary erosion control for this stockpile. Tonnage of clay shall be measured by Owner at the Scale House at the Rodefled Landfill Site (exact location of which is shown in Appendix B). Payment shall be made based on tonnage of clay received. The hours of operation of the Excavation Site will be 8:00 am – 4:00 pm, Monday through Friday. Rodefled Landfill is open to receive clay Monday through Friday, 7:00 am - 5:00 pm.

Owner will obtain all necessary permissions for trucks hauling from the Excavation Site. The following haul route must be used: Exit the borrow site toward the north and travel west on Easy Street for approximately ½ miles to the junction with County Trunk Highway I. Turn right and travel north on CTH I for approximately 3 miles to the junction with CTH V. Turn right and travel east on CTH V for approximately 1.2 miles to the junction with I-39/90/94. The interstate will then be followed south and east to the junction with USH 12-18 which will be taken east to the landfill. The total haul distance is approximately 24 miles. No route access restrictions are anticipated other than possible weight restrictions in early Spring on Easy Street. Contractor is responsible for having all necessary licenses and permits for trucks used by the Contractor for this work. Owner shall be responsible for obtaining all erosion control and construction permits necessary for this Work.

Work is expected to be completed by the following schedule:

- Anticipated contract award - April 1, 2014
- Deliver at least 39,000 tons of clay by June 16, 2014
- Deliver 78,000 tons of clay by July 7, 2014
- Restoration shall be completed by August 15, 2014

Base price shall be for hauling and excavating 78,000 tons of clay. As instructed on the bid sheet, bidder shall include line items for construction and maintenance of erosion control, site entrance and all other civil site work, clay excavation and hauling, and site restoration.

**Option B Alternate** expands the work to excavate up to 180,000 tons of clay from the Excavation Site and deposit it at the Rodefild Stockpile. Option B Alternate is subject to the same terms as Option B as spelled out above. Contractor shall be responsible for clay excavation, installation and maintenance of erosion control, site work, and restoration of impacted areas at the Excavation Site per drawings shown in Appendix A.

Work is expected to be completed by the following schedule:

Anticipated contract award - April 1, 2014  
Deliver at least 39,000 tons of clay by June 16, 2014  
Deliver 78,000 tons of clay by July 7, 2014  
Deliver 180,000 tons of clay by September 30, 2014  
Restoration shall be completed by October 15, 2014

Work shall be coordinated between Owner and Contractor.

### **Option C: Contractor to supply material**

Contractor shall supply 78,000 tons of clay from another source and deliver it to the Rodefeld Stockpile. Owner will stockpile all material once it is dumped at the stockpile location. Bids for option C shall be broken into a unit price per ton of clay delivered. Tonnage of clay shall be measured by Owner at the Scale House at the Rodefeld Landfill Site (exact location of which is shown in Appendix B). Payment shall be made based on tonnage of clay received. Rodefeld Landfill is open to receive clay Monday through Friday, 7:00 am - 5:00pm. Anticipated contract award date is April 1, 2014. At least 39,000 tons of clay shall be delivered by June 16, 2014 and the full 78,000 tons shall be delivered by July 7, 2014.

Clay shall meet all applicable requirements contained in Sections NR 500 and it's subsections, Wisconsin Administrative Code. Per NR 504.06 (2)(a) Supplied Clay must meet the following specifications:

1. A minimum of 50% by weight which passes the 200 sieve.
2. A saturated hydraulic conductivity of  $1 \times 10^{-7}$  cm/sec or less, when compacted to required moisture contents and densities based on the modified Proctor method, standard Proctor method, or a line of optimums method approved by the WIDNR.
3. An average liquid limit of 25 or greater with no values less than 20.
4. An average plasticity index of 12 or greater with no values less than 10.

Additionally, Owner stipulates:

5. All mining permits for the borrow site must be in place.

Bidder shall indicate on the bid sheet if the clay has been approved by the WDNR for use as landfill liner. If it has not, Owner shall be allowed access to the source site to conduct testing to receive WDNR approval. The time required to obtain approval and the cost of testing and permitting will be taken into consideration before awarding this option with a source that has not been approved. Dane County will be responsible for all cost and work necessary to obtain WDNR approval of clay source.

Appendix A

Excavation Site Plans

PROJECT NO. 314002  
 CLAY EXCAVATION AND TRUCKING  
 EASY STREET CLAY BORROW SITE – PHASE 1

PREPARED BY:  
 DANE COUNTY PUBLIC WORKS  
 SOLID WASTE DIVISION  
 JANUARY 2014

PROJECT LOCATION

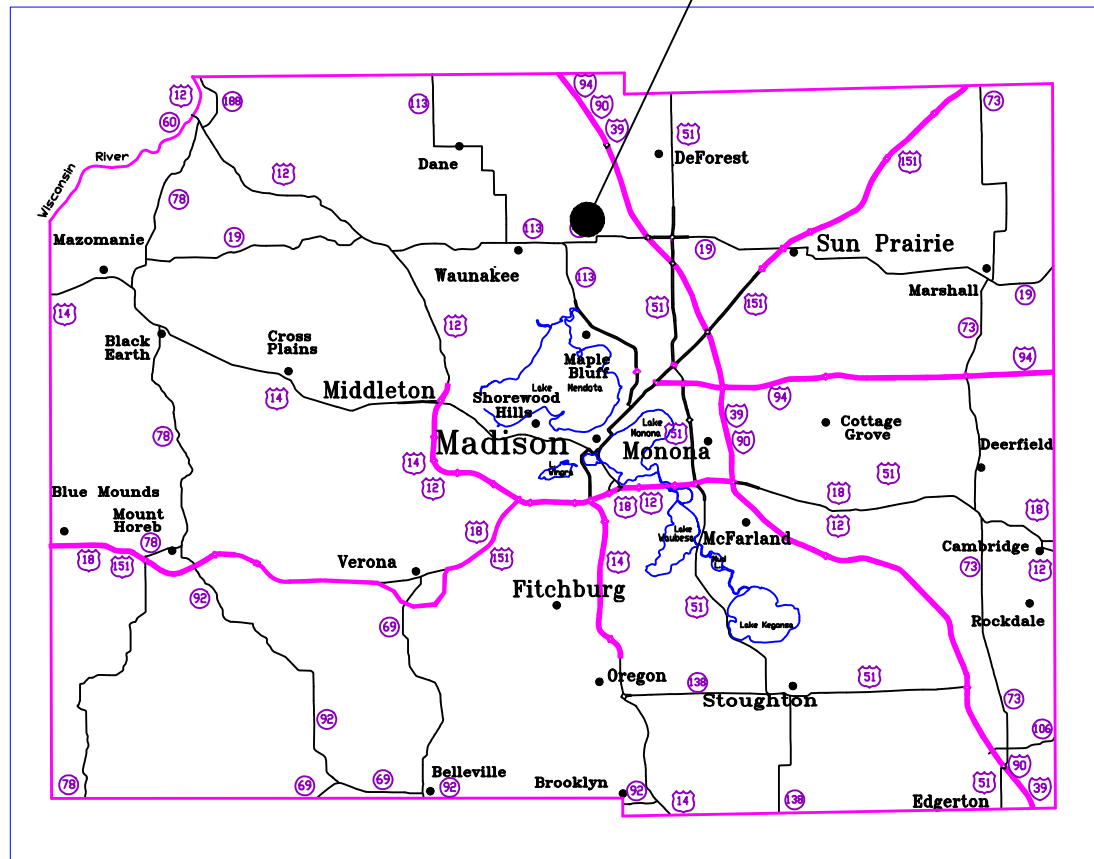

DANE COUNTY MAP

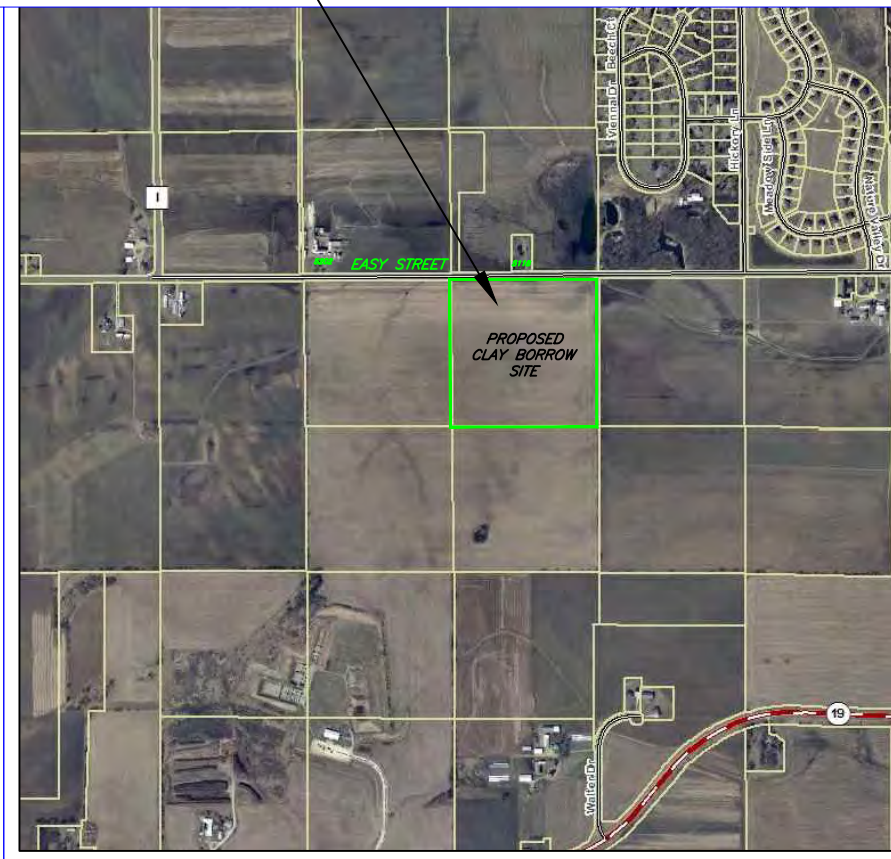

LOCATOR MAP

SHEET NUMBER	SHEET TITLE
1	TITLE SHEET
2	GENERAL NOTES
3	TRAFFIC CONTROL
4	HAUL ROUTE
5	EXISTING CONDITIONS
6	CLAY ISOPACH
7	EROSION CONTROL – PHASE 1
8	EROSION CONTROL DETAILS
9	EROSION CONTROL DETAILS
10	RECLAMATION PLAN – PHASE 1

*EROSION CONTROL NOTES:*

1. All erosion and sediment control practices will be installed and maintained in accordance with the following WDNR Technical Standards:

CHANNEL EROSION MAT (1053)  
 CONSTRUCTION SITE DIVERSION (1066)  
 DUST CONTROL (1068)  
 MULCHING FOR CONSTRUCTION SITES (1058)  
 SEEDING (1059)  
 STONE TRACKING PAD & TIRE WASHING (1057)  
 VEGETATIVE BUFFER FOR CONSTRUCTION SITES (1054)  
 SEDIMENT BASIN (1064)  
 SILT FENCE (1056)

2. All topsoil stockpiles, diversion berms and vegetated buffer area will be seeded with oats immediately after they are constructed.
3. All erosion and sediment control practices will be inspected at least weekly and within 24 hours after every precipitation event that produces 0.5 inches of rain or more during a 24 hour period.

*RESTORATION NOTES:*

1. Final reclaimed slopes covered by topsoil will not be steeper than a 3:1 horizontal to vertical incline.
2. Topsoil will be replaced to a minimum depth of 6 inches. Topsoil redistribution will not be performed during or immediately after a precipitation event until the soils have sufficiently dried.
3. Restored areas will be seeded with cereal (winter) rye at a rate of 131 lbs. Pure Live Seed/acre. Seeding will take place no later than October 15th.
4. The grassed waterway will be seeded according to NRCS FOTG Standard 342, Critical Area Planting and Erosion Matted.

*CONSTRUCTION SCHEDULE:*

Phase 1 (Eastern Parcel)  
 April 1, 2014 – Strip topsoil / construct erosion control practices  
 April 21, 2014 – Begin clay extraction  
 September 15, 2014 – End clay extraction / begin restoration  
 October 15, 2014 – Complete restoration









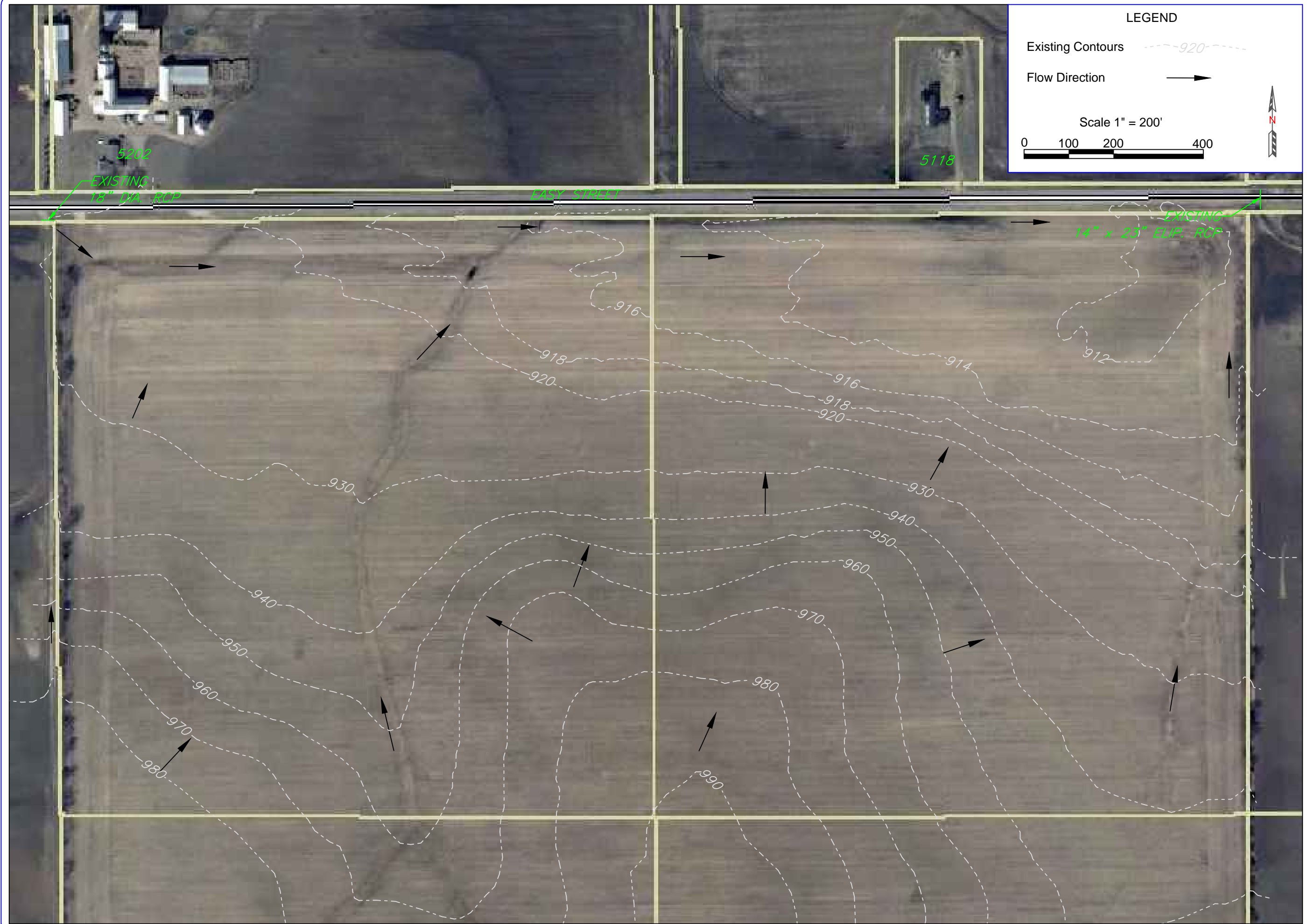



**LEGEND**

Existing Contours  920

Flow Direction 

Scale 1" = 200'

0 100 200 400

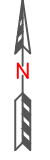

Approved By: JW  
 Drawn By: HR  
 Design By: HR  
 Date: Jan. 2014  
 Scale: As shown  
 Bid No: 314002

DEPARTMENT OF PUBLIC WORKS  
 DANE COUNTY WISCONSIN

EASY STREET  
 CLAY BORROW SITE  
 EXISTING CONDITIONS



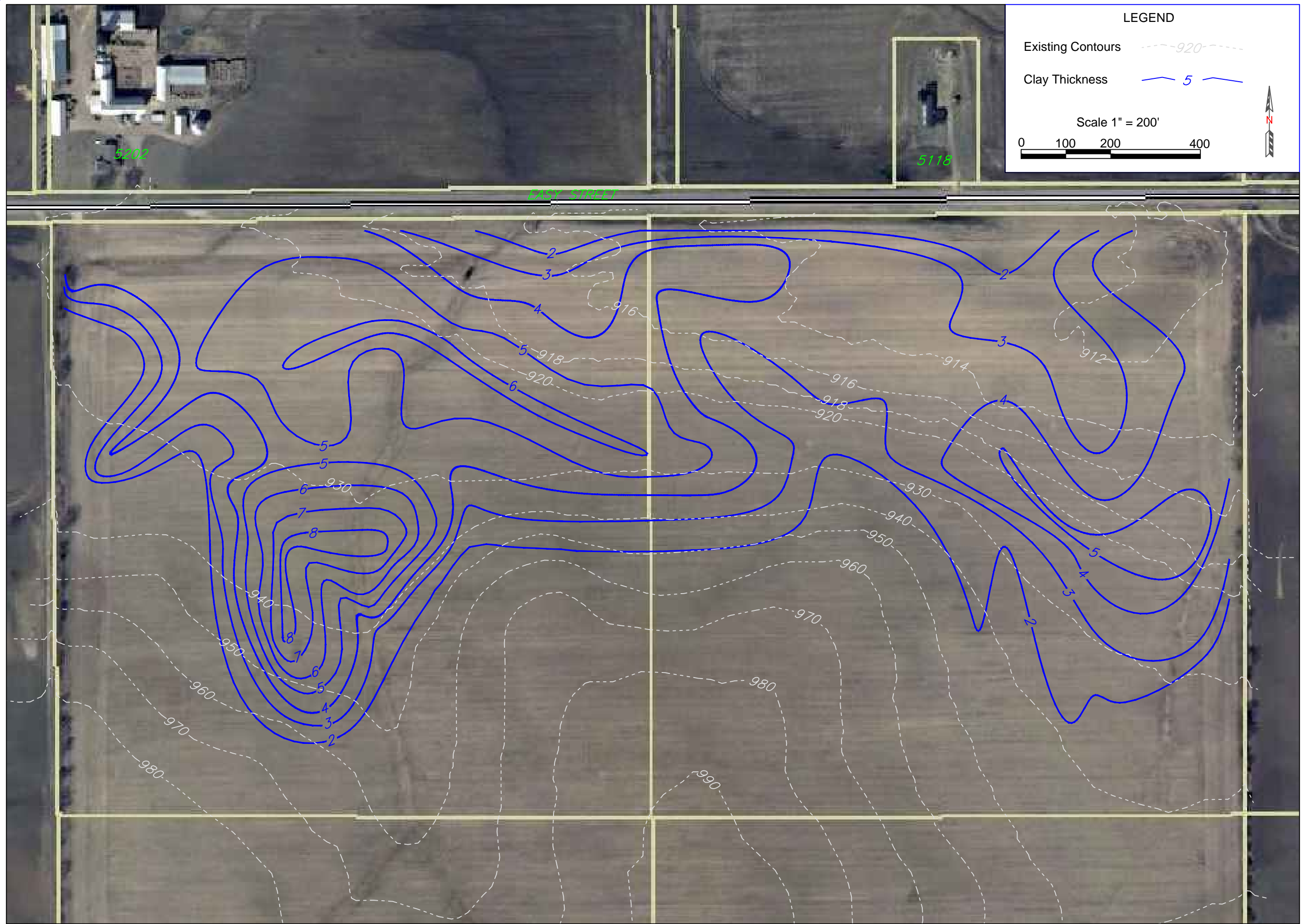

LEGEND

Existing Contours 

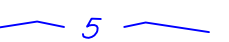
Clay Thickness 

Scale 1" = 200'

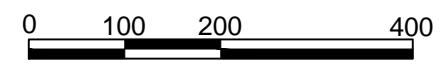

DEPARTMENT OF PUBLIC WORKS  
 DANE COUNTY WISCONSIN

EASY STREET  
 CLAY BORROW SITE  
 CLAY ISOPACH

Approved By: JW  
 Drawn By: HR  
 Design By: HR  
 Date: Jan. 2014  
 Scale: As shown  
 Bid No: 314002

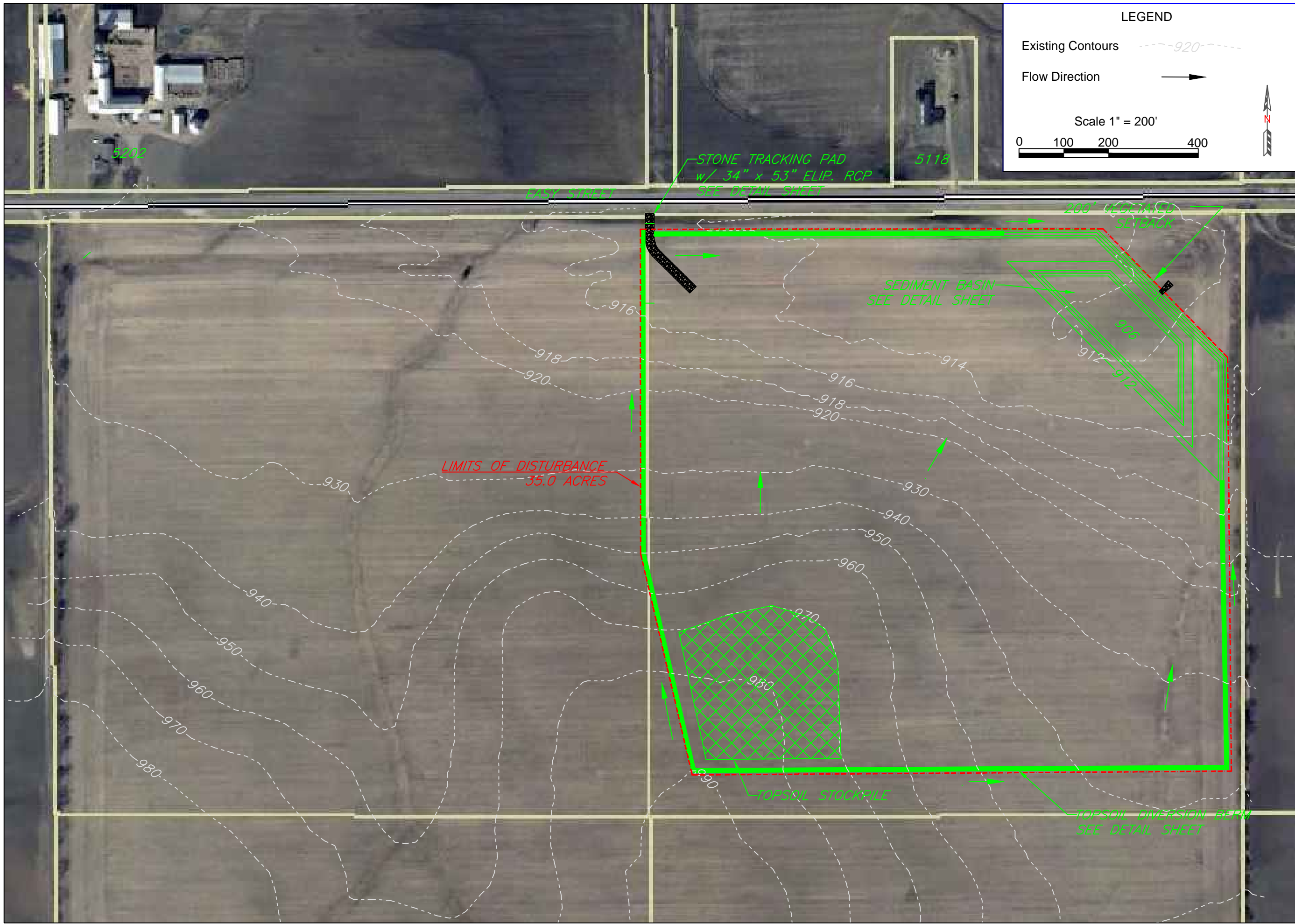

File Name:

Approved By: JW  
 Drawn By: HR  
 Design By: HR  
 Date: Jan. 2014  
 Scale: As shown  
 Bid No: 314002

DEPARTMENT OF PUBLIC WORKS  
 DANE COUNTY WISCONSIN

EASY STREET  
 CLAY BORROW SITE  
 PH. 1 EROSION CONTROL

Sheet 7  
 of 10

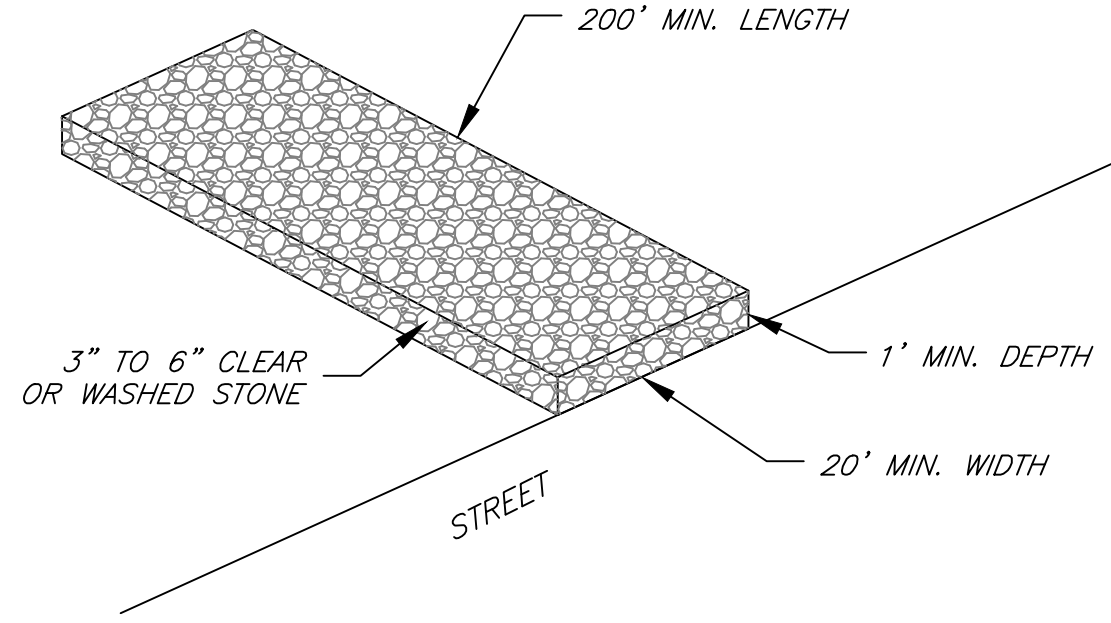

STONE TRACKING PAD

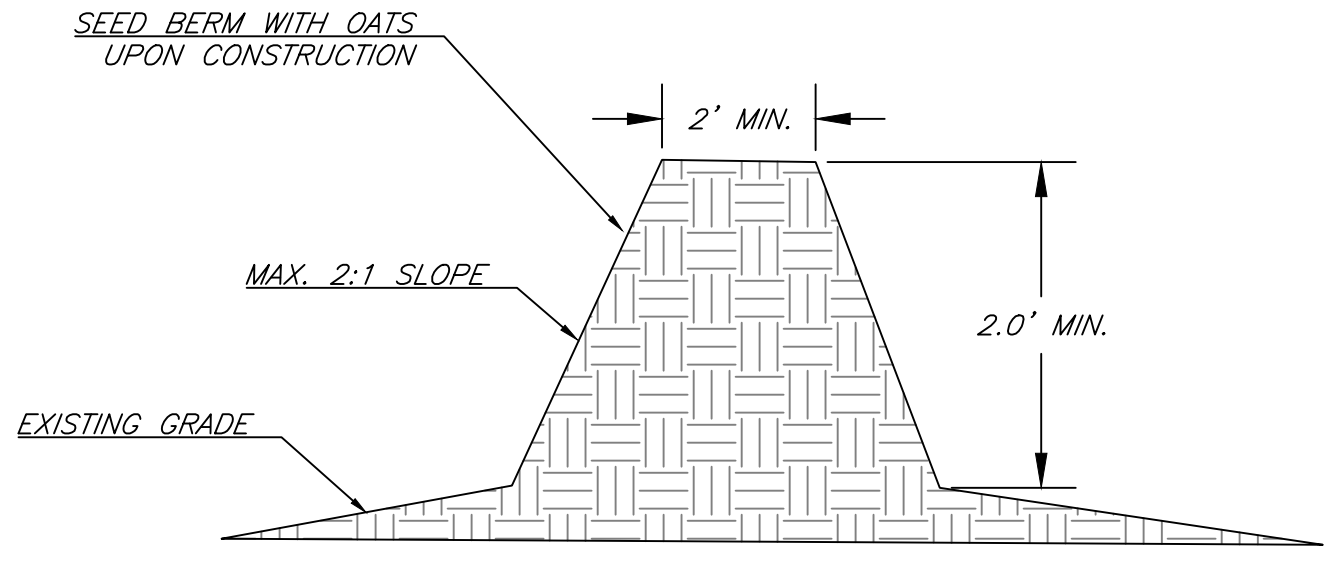

DIVERSION BERM CROSS SECTION

File Name:

Approved By: JW  
 Drawn By: HR  
 Design By: HR  
 Date: Jan. 2014  
 Scale: As shown  
 Bid No: 314002

DEPARTMENT OF PUBLIC WORKS  
 DANE COUNTY WISCONSIN

EASY STREET  
 CLAY BORROW SITE  
 EROSION CONTROL PLAN

Sheet 8  
 of 10

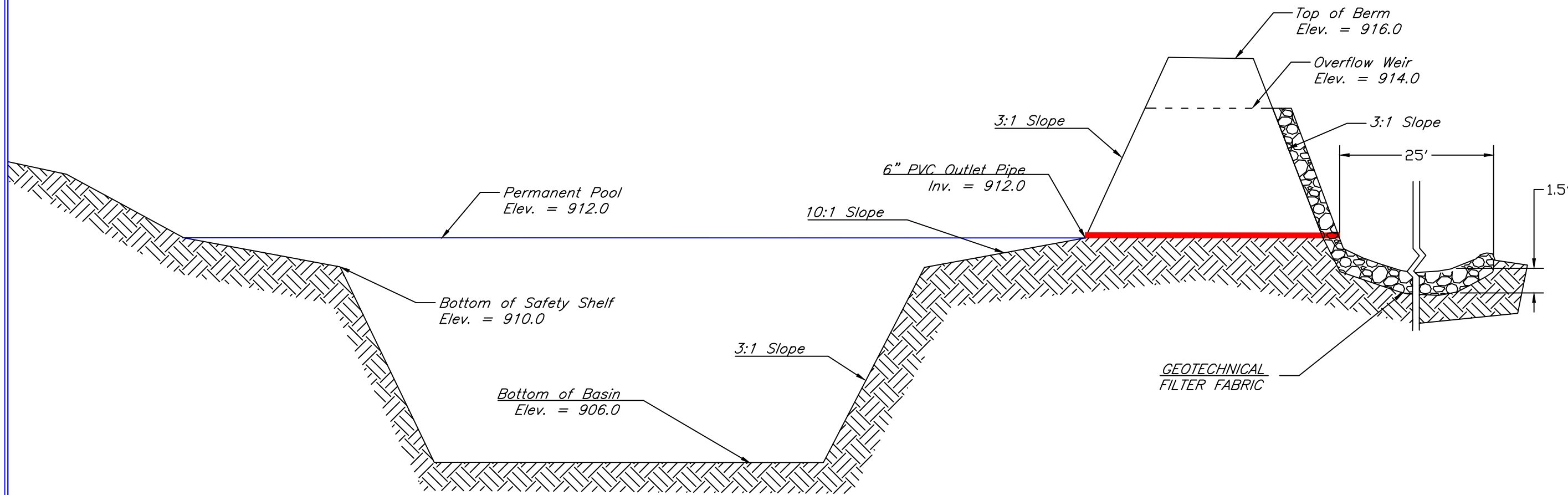

**PHASE 1 SEDIMENT BASIN CROSS SECTION**

Stone Gradation

Percent passing by weight	Size (inches)
100	12 in.
60-85	9 in.
25-50	6 in.
5-20	3 in.
0-5	1.2 in.

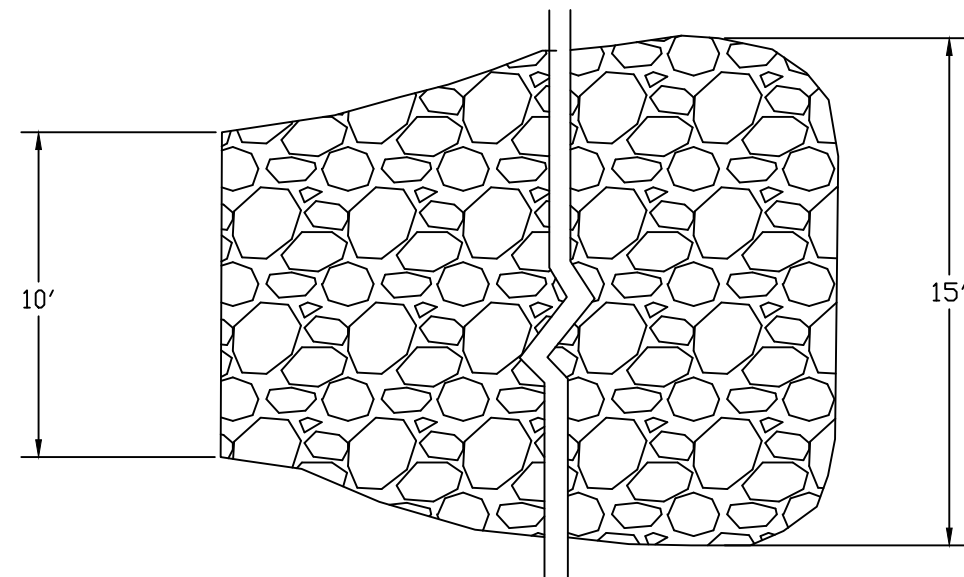

Approved By: JW  
 Drawn By: HR  
 Design By: HR  
 Date: Jan. 2014  
 Scale: As shown  
 Bid No: 314002

DEPARTMENT OF PUBLIC WORKS  
 DANE COUNTY WISCONSIN



EASY STREET  
 CLAY BORROW SITE  
 EROSION CONTROL PLAN



File Name:

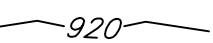

LEGEND

- Existing Contours 
- Proposed Contours 
- Flow Direction 

Scale 1" = 200'

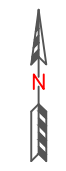
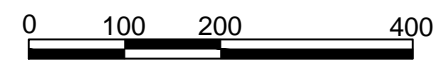

DEPARTMENT OF PUBLIC WORKS  
DANE COUNTY WISCONSIN

EASY STREET  
CLAY BORROW SITE  
PHASE 1 RECLAMATION

Sheet 10  
of 10

Design By: HR  
Drawn By: HR  
Approved By: JW  
Date: Jan. 2014  
Scale: As Shown  
Bid No: 314002



Appendix B

Drawing showing the location of the Rodefeld Stockpile within the Rodefeld Landfill Site (Landfill Site #2) located at 7102 U.S. Highway 12 & 18, Madison, WI.

★ Stockpile  
----- Driving Path (LENGTH = 9,000')

SCALE HOUSE

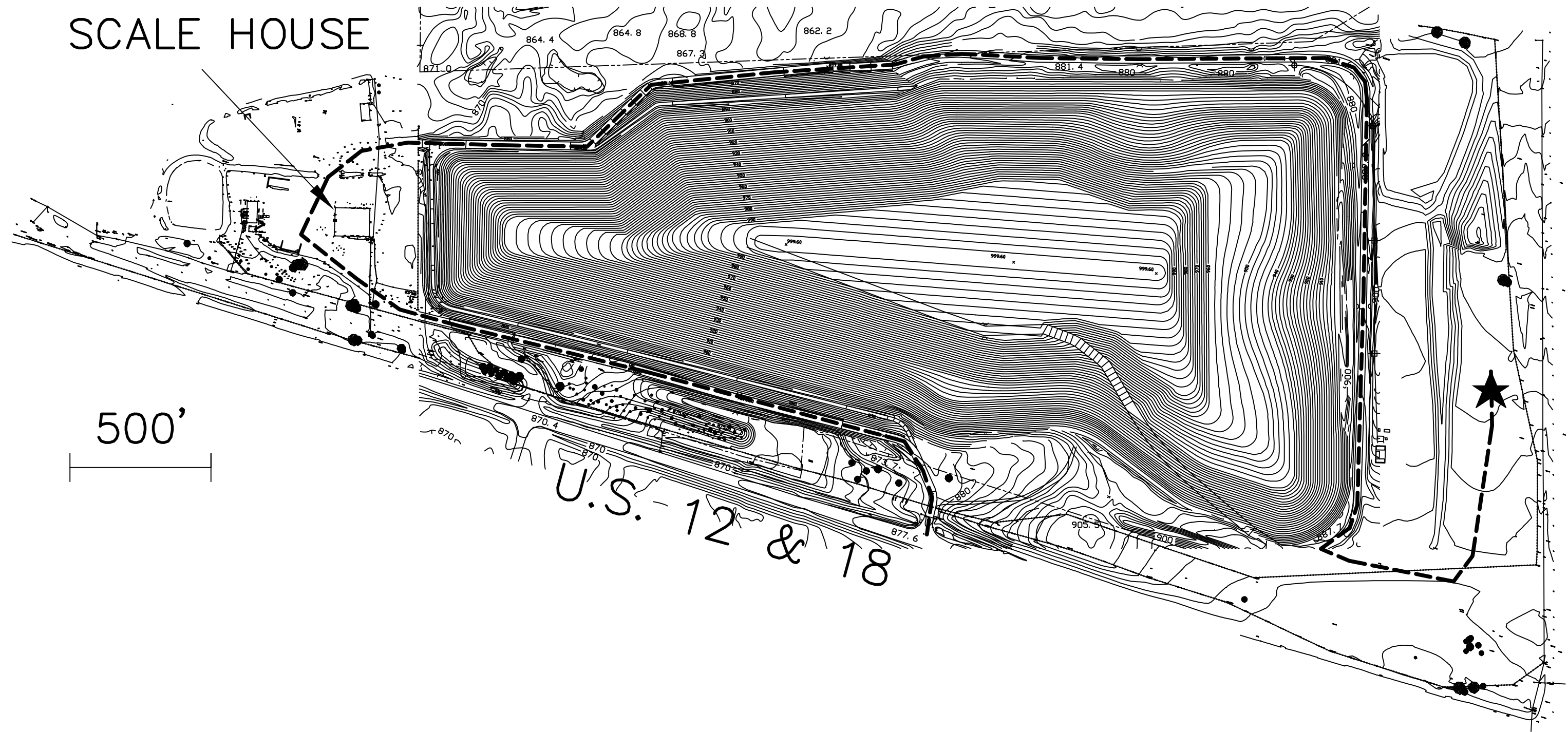

500'

U.S. - 12 & 18