

**RFB NO. 108074**



## **CONSTRUCTION DOCUMENTS PROJECT MANUAL**

DANE COUNTY DEPARTMENT OF PUBLIC WORKS,  
HIGHWAY AND TRANSPORTATION

PUBLIC WORKS ENGINEERING, DIVISION  
1919 ALLIANT ENERGY CENTER WAY  
MADISON, WISCONSIN 53713

### **REQUEST FOR BIDS NO. 108074 JOB CENTER ROOF REPLACEMENT DANE COUNTY JOB CENTER 1819 ABERG AVE. MADISON, WISCONSIN**

Opening Date: **TUESDAY, MAY 27, 2008**

Time: **2:00 P.M.**

Performance / Payment Bond: **100% OF CONTRACT AMOUNT**

Bid Deposit: **5% OF BID AMOUNT**

Location: **PUBLIC WORKS OFFICE**

---

FOR INFORMATION ON THIS REQUEST FOR BIDS, PLEASE CONTACT:

**TOM SRACIC, PROJECT MANAGER**  
TELEPHONE NO.: 608/266-4475  
FAX NO.: 608/267-1533  
E-MAIL: SRACIC@CO.DANE.WI.US

## **DOCUMENT INDEX FOR RFB NO. 108074**

### **PROCUREMENT AND CONTRACTING REQUIREMENTS**

Project Manual Cover Page  
Documents Index and Dane County Vendor Registration Program  
Invitation to Bid (Legal Notice)  
Instructions to Bidders  
Bid Form  
Fair Labor Practices Certification  
Sample Public Works Contract  
Sample Bid Bond  
Sample Performance Bond  
Sample Payment Bond  
General Conditions of Contract  
Supplementary Conditions  
Prevailing Wage Rates

### **DIVISION 1 - GENERAL REQUIREMENTS**

01000 - Basic Requirements  
01058 - Recycling

### **DIVISION 2 - SITE CONSTRUCTION**

Not Used.

### **DIVISION 3 - CONCRETE**

Not Used.

### **DIVISION 4 - MASONRY**

Not Used.

### **DIVISION 5 - METALS**

Not Used.

### **DIVISION 6 - WOOD AND PLASTICS**

06 10 00 - Rough Carpentry

### **DIVISION 7 - THERMAL AND MOISTURE PROTECTION**

07 53 00 - Elastomeric Membrane Roofing  
07 54 00 - Thermoplastic Membrane Roofing  
07 62 00 - Flashing And Sheet Metal  
07 72 00 - Roof Accessories

### **DIVISION 8 - DOORS AND WINDOWS**

Not Used.

### **DIVISION 9 - FINISHES**

Not Used.

### **DIVISION 10 - SPECIALTIES**

Not Used.

### **DIVISION 11 - EQUIPMENT**

Not Used.

**DIVISION 12 - FURNISHINGS**

Not Used.

**DIVISION 13 - SPECIAL CONSTRUCTION**

Not Used.

**DIVISION 14 - CONVEYING SYSTEMS**

Not Used.

**DIVISIONS 21 - 33**

Not Used.

**DRAWINGS**

TS1 Title Sheet

A103 Roof demolition Plan

A202 Roof Plan & Roof Details

**DANE COUNTY VENDOR REGISTRATION PROGRAM**

All bidders / proposers wishing to submit a bid / proposal should be registered with Dane County Purchasing before bid / proposal opening & must be registered before award of contract. Complete a Vendor Registration Form at [www.danepurchasing.com](http://www.danepurchasing.com), or obtain one by calling 608/266-4131.

## LEGAL NOTICE

### INVITATION TO BID

Dane County Department of Public Works, Highway & Transportation, 1919 Alliant Energy Center Way, Madison, WI 53713, will receive sealed Bids until:

**2:00 P.M., TUESDAY, MAY 27, 2008**

**BID NO. 108074**

**JOB CENTER ROOF REPLACEMENT  
1819 ABERG AVENUE  
MADISON, WI**

Dane County is inviting Bids for removal of approximately 80,000 sq. ft. of existing roofing and insulation. Replace with 60 mil. fully adhered EPDM roofing and polyisocyanurate insulation.

Request For Bids package may be obtained after 2:00 p.m. on Wednesday, May 7, 2008, at Dane County Public Works, Highway & Transportation Dept., 1919 Alliant Energy Center Way, Madison, WI 53713, by calling 608-266-4018, or downloading it from [www.countyofdane.com/pwht/bid/logon.aspx](http://www.countyofdane.com/pwht/bid/logon.aspx). Please call Tom Sracic, Project Manager, at 608-266-4475, for any questions or additional information.

All Bidders wishing to submit Bids should be a registered vendor with Dane County Purchasing & prequalified as Best Value Contractor before bid opening & must be registered & prequalified before award of contract. Complete Vendor Registration Form at [www.danepurchasing.com](http://www.danepurchasing.com) or obtain one by calling 608-266-4131. Complete Prequalification Application for Contractors at [www.co.dane.wi.us/pwht/pwengineer.aspx](http://www.co.dane.wi.us/pwht/pwengineer.aspx) or obtain one by calling 608-266-4018.

Pre-Bid Meeting will be held on Tuesday, May 20<sup>th</sup> at 10:00 a.m. Meet at the Job Center main entrance at 1819 Aberg Avenue. Bidders are strongly encouraged to attend.

**PUBLISH:      MAY 7 & 14, 2008 - WISCONSIN STATE JOURNAL  
                    MAY 12 & 19, 2008 - WESTERN BUILDER**

# INSTRUCTIONS TO BIDDERS

## TABLE OF CONTENTS

1. GENERAL .....	1
2. DRAWINGS AND SPECIFICATIONS .....	1
3. INTERPRETATION.....	2
4. QUALIFICATIONS OF BIDDER (CONTRACTOR AND SUBCONTRACTOR) ....	2
5. BID GUARANTEE .....	3
6. WITHDRAWAL OF BIDS .....	3
7. CONTRACT FORM.....	3
8. CONTRACT INTERESTS BY COUNTY PUBLIC OFFICIALS .....	4
9. EMERGING SMALL BUSINESS PROVISIONS .....	4
10. METHOD OF AWARD - RESERVATIONS .....	6
11. SECURITY FOR PERFORMANCE AND PAYMENTS.....	6
12. TAXES.....	7
13. SUBMISSION OF BIDS .....	7
14. SUBCONTRACTOR LISTING .....	8
15. ALTERNATE BIDS .....	8
16. INFORMATIONAL BIDS .....	8
17. UNIT PRICES .....	8
18. COMMENCEMENT AND COMPLETION.....	9
19. WORK BY COUNTY.....	9
20. SPECIAL HAZARDS COVERAGE .....	9
FORM A .....	10
FORM B.....	11
FORM C.....	12
FORM D .....	13

### **1. GENERAL**

- A. Before submitting Bid, bidder shall thoroughly examine all Construction Documents. Successful Bidder shall be required to provide all the Work that is shown on Drawings, set forth in Specifications, or reasonably implied as necessary to complete Contract for this project.
- B. Bidder shall visit site to become acquainted with adjacent areas, means of approach to site, conditions of actual site and facilities for delivering, storing, placing, and handling of materials and equipment.
- C. Pre-bid meeting is scheduled on Tuesday, May 20, 2008 at 10:00 AM, at The Dane County Job Center, 1819 Aberg Ave., Madison Wi., in front of the main entrance to the Job Center. Attendance by all bidders is optional, however bidders and subcontractors are strongly encouraged to attend.
- E. Failure to visit site or failure to examine any and all Construction Documents will in no way relieve successful Bidder from necessity of furnishing any necessary materials or equipment, or performing any work, that may be required to complete the Work in accordance with Drawings and Specifications. Neglect of above requirements will not be accepted as reason for delay in the Work or additional compensation.

### **2. DRAWINGS AND SPECIFICATIONS**

- A. Drawings and Specifications that form part of this Contract, as stated in Article 1 of General Conditions of Contract, are enumerated in Document Index of these Construction Documents.
- B. Complete sets of Drawings and Specifications for all trades will be issued to all Bidders, irrespective of category of work to be bid on, in order that all Bidders may be familiar with work of other trades as they affect their bid.

### **3. INTERPRETATION**

- A. No verbal explanation or instructions will be given in regard to meaning of Drawings or Specifications before Bid Opening. Bidders shall bring inadequacies, omissions or conflicts to County Manager's attention at least ten (10) days before Bid Opening. Prompt clarification will be available to all bidders by Addendum.
- B. Failure to so request clarification or interpretation of Drawings and Specifications will not relieve successful Bidder of responsibility. Signing of Contract will be considered as implicitly denoting that Contractor has thorough understanding of scope of the Work and comprehension of Construction Documents.
- C. County Manager will not be responsible for verbal instructions.

### **4. QUALIFICATIONS OF BIDDER (CONTRACTOR AND SUBCONTRACTOR)**

- A. Before award of Contract can be approved, County shall be satisfied that Bidder involved meets following requirements:
  - 1. Has completed at least one (5) projects of at least fifty percent (50%) of size or value and at least (2) projects of this size or value or larger within the last ten (10) years, of Division of work being bid and type of work completed is similar to that being bid. If greater magnitude of experience is deemed necessary, other than size or value of work, such requirements will be described in appropriate section of Specifications.
  - 2. Maintains permanent place of business.
  - 3. Can be bonded for terms of proposed Contract.
  - 4. Has record of satisfactorily completing past projects and supplies list of five (5) most recent, similar projects, with architect or engineer's and owner's names, addresses and telephone numbers for each project. Submit to Public Works Project Manager with Bid Documents at Bid Opening]. Criteria which will be considered in determining satisfactory completion of projects by bidder will include:
    - a) Completed contracts in accordance with drawings and specifications.
    - b) Diligently pursued execution of work and completed contracts according to established time schedule unless Owner grants extensions.
    - c) Fulfilled guarantee requirements of construction documents.
    - d) Is not presently on ineligible list maintained by County's Department of Administration for noncompliance with equal employment opportunities and affirmative action requirements.
    - e) Authorized to conduct business in Wisconsin. By submitting Bid, bidder warrants that it has: complied with all necessary requirements to do business in State of Wisconsin; that persons executing contract on its behalf are authorized to do so; and, if corporation, that name and address of bidder's registered agent are as set forth in

Contract. Bidder shall notify County immediately, in writing, of any change in its registered agent, their address, and bidder's legal status. For partnership, term "registered agent" shall mean general partner.

- B. County's Public Works Project Manager will make such investigations as are deemed necessary to determine ability of bidder to perform the Work, and bidder shall furnish to County's Public Works Project Manager or designee all such information and data for this purpose as County's Public Works Project Manager may request. County reserves right to reject Bid if evidence submitted by, or investigation of, bidder fails to satisfy County that bidder is responsible and qualified to carry out obligations of Contract and to complete the Work contemplated therein.

## **5. BID GUARANTEE**

- A. Bank certified check, cashier's check or Bid Bond, payable to County in amount not less than five percent (5%) of maximum bid, shall accompany each Bid as guarantee that if Bid is accepted, Bidder will execute and return proposed Contract and Performance and Payment Bonds within ten (10) days after being notified of acceptance of Bid. Company issuing bonds must be licensed to do business in Wisconsin.
- B. Any bid, which is not accompanied by bid guarantee, will be considered "No Bid" and will not be read at Bid Opening.
- C. If successful Bidder so delivers Contract, Certificate of Insurance, and Performance and Payment Bonds, check will be returned to Bidder. In case Bidder fails to deliver such Contract, insurance, and bond, amount of bid guarantee will be forfeited to County as liquidated damages.
- D. All checks tendered as bid guarantee, except those of three lowest qualified, responsible bidders, will be returned to their makers within three (3) days after Bid Opening. All such retained checks will be returned immediately upon signing of Contract and Performance and Payment Bonds by successful Bidder.

## **6. WITHDRAWAL OF BIDS**

- A. Bids may be withdrawn by written request received from bidder or authorized representative thereof prior to time fixed for Bid Opening, without prejudice to right of bidder to file new Bid. Withdrawn Bids will be returned unopened. Negligence on part of bidder in preparing their Bid confers no right for withdrawal of Bid after it has been opened.
- B. No Bid may be withdrawn for period of sixty (60) days after Bid Opening date.
- C. If Bid contains error, omission or mistake, bidder may limit liability to amount of bidder's guarantee by giving written Notice of Intent not to execute Contract to County within seventy-two (72) hours of Bid Opening.

## **7. CONTRACT FORM**

- A. Sample copy of contract that successful Bidder will be required to enter into is included in these Construction Documents and bidders are required to familiarize themselves with all conditions contained therein.

## **8. CONTRACT INTERESTS BY COUNTY PUBLIC OFFICIALS**

- A. In accordance with Wisconsin Statute 946.13, county official may not bid for or enter into any contract involving receipts or disbursements of more than \$7,500.00 in a year, in which they have private pecuniary interest, direct or indirect if at same time they are authorized to take official action with respect to making of this Contract. Any contract entered into in violation of this Statute is void and County incurs no liability thereon. This subsection does not affect application and enforcement of Wisconsin Statute 946.13 by state prosecutors in criminal courts of this state.

## **9. EMERGING SMALL BUSINESS PROVISIONS**

- A. **Emerging Small Business Definition.** For purposes of this provision, ESB is defined as:
  - 1. Independent business concern that has been in business minimum of one year;
  - 2. Business located in State of Wisconsin;
  - 3. Business comprised of less than 25 employees;
  - 4. Business must not have gross sales in excess of three million dollars (\$3,000,000.00) over past three years; and
  - 5. Business does not have history of failing to complete projects.
- B. **Emerging Small Business (ESB) Involvement.** Bidder shall make good faith effort to award minimum of ten percent (10%) of the Work to ESBs. Bidder shall submit report to Dane County Contract Compliance Officer within twenty-four (24) hours after Bid Opening demonstrating such efforts. Good faith efforts means significant contact with ESBs for purposes of soliciting bids from them. Failure to make or demonstrate good faith efforts will be grounds for disqualification.
- C. **Emerging Small Business Report.** Emerging Small Business Enterprise Report is to be submitted by Bidder in separate envelope marked "Emerging Small Business Report". This report is due by 2:00 p.m. following specified twenty-four (24) hours after Bid Opening. Bidder who fails to submit Emerging Small Business Report shall be deemed not responsive.
- D. **ESB Goal.** Ten percent (10%) ESB participation is goal of this project. ESB utilizations are shown as percentage of total Bid. If Bidder meets or exceeds specified goal, Bidder is only required to submit Form A - Certification, and Form B - Involvement. Goal shall be met if Bidder qualifies as ESB.
- E. **Report Contents.** Following award of Contract, Bidder shall submit copies of executed contracts for all Emerging Small Businesses. Emerging Small Business Report shall consist of these:



1. Form A - Certification;
  2. Form B - Involvement;
  3. Form C - Contacts;
  4. Form D - Certification Statement (if appropriate); and
  5. Supportive documentation (i.e., copies of correspondence, telephone logs, copies of advertisements).
- F. **ESB Listing.** Bidders will solicit bids from ESB listing provided by Dane County.
- G. **ESB Certification.** All contractors, subcontractors and suppliers seeking ESB certification must complete and submit Emerging Small Business Certification Application to Dane County Contract Compliance Program.
- H. **Certification Statement.** If ESB firm has not been certified by County as ESB prior to submittal of this Bid, ESB Report cannot be used to fulfill ESB goal for this project unless firm provides "Form D - Certification Statement". Certification statement must be completed and signed by ESB firm.
- I. **Questions.** Questions concerning Emerging Small Business provisions shall be directed to:  
Dane County Contract Compliance Officer  
City-County Building, Room 421  
210 Martin Luther King, Jr. Blvd.  
Madison, WI 53703  
608/266-5623
- J. **Substituting ESBs.** In event of any significant changes in subcontract arrangements or if need arises to substitute ESBs, Bidder shall report such proposed changes to Contract Compliance Officer to making any official changes and request authorization to substitute ESB firm. Bidder further agrees to make every possible effort to replace ESB firm with another qualified ESB firm.
- K. **Good Faith Efforts.** Good faith efforts can be demonstrated by meeting all of these obligations:
1. Selecting portions of the Work to be performed by ESBs in order to increase likelihood of meeting ESB goal including, where appropriate, breaking down Contract into smaller units to facilitate ESB participation.
  2. Advertising in general circulation, trade associations, and women / minority focus media concerning subcontracting opportunities.
  3. Providing written notices to reasonable number of specific ESBs that their interest in Contract was being solicited in sufficient time to allow ESBs to participate effectively.
  4. Following up on initial solicitations of interest by contacting ESBs within five (5) working days prior to Bid Opening date to determine with certainty whether ESB were interested, to allow ESBs to prepare bids.

5. Providing interested ESB with adequate information about Drawings, Specifications and requirements of Contract.
  6. Using services of available minority, women and small business organizations and other organizations that provide assistance in recruitment of MBEs / WBEs / ESBs.
  7. Negotiating in good faith with interested ESBs, not rejecting ESBs as unqualified without sound reason based on thorough investigation of their capabilities.
  8. Submitting required project reports and accompanying documents to County's Contract Compliance Officer within twenty-four (24) hours after Bid Opening.
- L. **Appeals Disqualification of Bid.** Bidder who is disqualified may appeal to Public Works & Transportation Committee and Equal Opportunity Commission.

## **10. METHOD OF AWARD - RESERVATIONS**

- A. Following will be basis of award of Contract, providing cost does not exceed amount of funds then estimated by County as available to finance Contract(s):
1. Lowest dollar amount submitted by qualified responsible bidder on Base Bid for all work comprising project, combined with such additive Owner accepted alternates.
  2. County reserves right to reject all bids or any bid, to waive any informality in any bid, and to accept any bid that will best serve interests of County.
  3. Unit Prices and Informational Bids will not be considered in establishing low bidder.

## **11. SECURITY FOR PERFORMANCE AND PAYMENTS**

- A. Simultaneous with delivery of signed Contract, Bidder shall be required to furnish Performance and Payment Bonds as specified in Article 29 of General Conditions of Contract, "Contract Security". Surety Company shall be licensed to do business in Wisconsin. Performance and Payment Bonds must be dated same date or subsequent to date of Contract. Performance and Payment Bonds must emulate information in Sample Performance and Payment Bonds in Construction Documents.
- B. Provide certified copy of power of attorney from Surety Company showing that agent who signs Bond has power of attorney to sign for Surety Company. Secretary or Assistant Secretary of company must sign this certification, not attorney-in-fact. Certification must bear same or later date as Bond. Power of Attorney must emulate model power of attorney information detailed in Sample Performance and Payment Bonds.
- C. If Bidder is partnership or joint venture, State certified list, providing names of individuals constituting partnership or joint venture must be furnished. Contract itself may be signed by one partner of partnership, or one partner of each firm comprising joint venture, but Performance and Payment Bonds must be signed by all partners.
- D. If Bidder is a corporation, it is necessary that current certified copy of resolution or other official act of directors of corporation be submitted showing that person who signs Contract is authorized to sign contracts for corporation. It is also necessary that corporate seal be affixed to resolution, contract, and performance and payment bonds. If your corporation has no seal,

it is required that above documents include statement or notation to effect that corporation has no seal.

## **12. TAXES**

- A. Bidder shall include in Bid, all Sales, Consumer, Use and other similar taxes required by law.
- B. In accordance with Wisconsin Statute 71.80(16)(a), successful nonresident bidder, whether incorporated or not, and not otherwise regularly engaged in business in this state, shall file surety bond with State of Wisconsin Department of Revenue payable to Department of Revenue, to guarantee payment of income taxes, required unemployment compensation contributions, sales and use taxes and income taxes withheld from wages of employees, together with any penalties and interest thereon. Amount of bond shall be three percent (3%) of Contract or subcontract price on all contracts of \$50,000 or more.

## **13. SUBMISSION OF BIDS**

- A. All Bids shall be submitted on standard Bid Form bound herein and only Bids that are made on this Bid Form will be considered. Entire Bid Form and other supporting documents, if any, shall be removed or copied from Construction Documents, filled out, and submitted in manner specified hereinafter. Submit completed Bid Bond with Bid as well.
- B. No bids for any subdivision or any sub-classification of this Work, except as indicated, will be accepted. Any conditional Bid, amendment to Bid Form or appended item thereto, or inclusion of any correspondence, written or printed matter, or details of any nature other than that specifically called for, which would alter any essential provision of Construction Documents, or require consideration of unsolicited material or data in determining award of Contract, will disqualify Bid. Telecommunication alterations to Bid will not be accepted.
- C. Bidders must submit single Bid for all the Work.
- D. Bid amounts shall be inserted in words and in figures in spaces provided on Bid Form; in case of conflict, written word amounts will govern.
- E. Addenda issued after Bid Letting shall become part of Construction Documents. Bidders shall acknowledge receipt of such addenda in appropriate space provided on Bid Form. Bid will be rejected if receipt of any particular addendum applicable to award of Contract has not been acknowledged on Bid Form.
- F. All bidders are encouraged to submit their bids in special printed bid envelope available at Dane County Public Works, Highway & Transportation Department - Public Works Engineering Division. Bids submitted in any other type of envelope run risk of not being identified as bid and County shall not be liable therefore in any respect. Bids shall be signed, sealed and delivered at place and before time of closing designated in Invitation to Bid, and identified with project name, bid number, location, category of work being bid upon, Bid Opening date, name and address of bidder.
- G. Bidder shall be responsible for sealed Bid being delivered to place designated for Bid Opening on or before date and time specified. Bids received after time of closing will be rejected and returned to bidder unopened.

- H. Bid will be considered invalid and will be rejected if bidder has not signed it.
- I. Faxed Bids will not be accepted.

#### **14. SUBCONTRACTOR LISTING**

- A. Bidders shall be required to submit list of major subcontractors for General Construction, Plumbing, HVAC, and Electrical work proposed for this project to include committed prices for each subcontractor. List shall be placed in separate sealed envelope that must be clearly identified as "Major Subcontractor List", for named project and name of Bidder submitting it. County must receive envelope no later than date by which successful Bidder is required to submit his or her signed Contract, as established in Construction Documents.

#### **15. ALTERNATE BIDS**

- A. Bidder shall carefully read requests for Alternate Bids, and thoroughly examine Drawings and Specifications to determine extent various changes and conditions will affect Bid.
- B. Space is provided in Bid Form for requested Alternate Bids. Failure to submit bid for any requested Alternate Bids may result in rejection of entire Bid.
- C. Bidder shall state amount to be added / subtracted to Base Bid for providing alternates, including all incidentals, omissions, additions, and adjustments as may be necessary or required by such changes. If there is no difference in price, Bidder shall state, "No Change".
- D. Descriptions of requested Alternate Bids are as set forth in Construction Documents.

#### **16. INFORMATIONAL BIDS**

- A. Bidder shall state amount that is included in Base Bid for all equipment, materials and labor required to complete the Work described. Informational bids are amounts requested for accounting purposes and for allocation of funds only. It is not intended to omit any of the Work described or related items from this project.
- B. Description of requested Informational Bids, if any, is as set forth in Construction Documents.

#### **17. UNIT PRICES**

- A. Provide unit prices where requested on Bid Form. Unit prices will include all costs for materials, labor, insurance, taxes, overhead and profit necessary to perform specified work. Estimated quantities are approximate only. Payment will be based upon actual quantities placed, provided or installed. Failure to provide requested unit prices may result in rejection of entire Bid.
- B. County reserves right to accept or reject any unit prices as given in Bid.
- C. Bidder shall refer to Bid Form and applicable specification section to determine basis of unit measure and detailed information related to each unit price item requested.

## **18. COMMENCEMENT AND COMPLETION**

- A. Successful Bidder shall commence work when schedule and weather permit, but no later than stated in Bid Form. Contractor shall pursue the Work regularly and continuously at reasonable rate to insure completion of the Work within time stated in Bid.
- B. Should it be found impossible to complete the Work on or before time specified for completion, written request may be submitted for extension of time setting forth reasons believed to justify granting of such request. Refer to Article 20 of General Conditions of Contract, titled "Time for Completion".

## **19. WORK BY COUNTY**

- A. Not Applicable.

## **20. SPECIAL HAZARDS COVERAGE**

- A. Not Applicable.
- A. If hazardous materials abatement work is required by Construction Documents, successful Bidder shall provide necessary Pollution Insurance that specifically includes coverage for hazardous materials abatement work as called for under "Insurance" in Supplementary Conditions.

**FORM A**

**DANE COUNTY  
EMERGING SMALL BUSINESS REPORT - CERTIFICATION**

In accordance with General Conditions of Contract, submit this Emerging Small Business Report within 24 hours after Bid Opening.

PROJECT NAME: \_\_\_\_\_

\_\_\_\_\_

BID NO.: \_\_\_\_\_ BID OPENING DATE: \_\_\_\_\_

**BIDDER INFORMATION**

COMPANY NAME: \_\_\_\_\_

ADDRESS: \_\_\_\_\_

\_\_\_\_\_

TELEPHONE NO.: \_\_\_\_\_

CONTACT PERSON: \_\_\_\_\_

**FORM B**

**DANE COUNTY  
EMERGING SMALL BUSINESS REPORT - INVOLVEMENT**

Page \_\_\_ of \_\_\_

(Copy this Form as necessary to provide complete information)

COMPANY NAME: \_\_\_\_\_

PROJECT NAME: \_\_\_\_\_ BID NO.: \_\_\_\_\_

ESB NAME: \_\_\_\_\_ CONTACT PERSON: \_\_\_\_\_

ADDRESS: \_\_\_\_\_ PHONE NO.: \_\_\_\_\_

CITY: \_\_\_\_\_ STATE: \_\_\_\_\_ ZIP: \_\_\_\_\_

**Indicate percentage of financial commitment to this ESB: \_\_\_\_\_ % Amount: \$ \_\_\_\_\_**

ESB NAME: \_\_\_\_\_ CONTACT PERSON: \_\_\_\_\_

ADDRESS: \_\_\_\_\_ PHONE NO.: \_\_\_\_\_

CITY: \_\_\_\_\_ STATE: \_\_\_\_\_ ZIP: \_\_\_\_\_

**Indicate percentage of financial commitment to this ESB: \_\_\_\_\_ % Amount: \$ \_\_\_\_\_**

ESB NAME: \_\_\_\_\_ CONTACT PERSON: \_\_\_\_\_

ADDRESS: \_\_\_\_\_ PHONE NO.: \_\_\_\_\_

CITY: \_\_\_\_\_ STATE: \_\_\_\_\_ ZIP: \_\_\_\_\_

**Indicate percentage of financial commitment to this ESB: \_\_\_\_\_ % Amount: \$ \_\_\_\_\_**

**FORM C**

**DANE COUNTY  
EMERGING SMALL BUSINESS REPORT - CONTACTS**

Page \_\_\_ of \_\_\_

(Copy this Form as necessary to provide complete information)

COMPANY NAME: \_\_\_\_\_

PROJECT NAME: \_\_\_\_\_ BID NO.: \_\_\_\_\_

	<u>ESB FIRM NAME CONTACTED</u>	<u>DATE</u>	<u>PERSON CONTACTED</u>	<u>DID ESB BID?</u>	<u>DID YOU ACCEPT BID?</u>	<u>REASON FOR REJECTION</u>
1)	_____	_____	_____	_____	_____	_____
2)	_____	_____	_____	_____	_____	_____
3)	_____	_____	_____	_____	_____	_____
4)	_____	_____	_____	_____	_____	_____
5)	_____	_____	_____	_____	_____	_____
6)	_____	_____	_____	_____	_____	_____
7)	_____	_____	_____	_____	_____	_____



**FORM D**

**DANE COUNTY  
EMERGING SMALL BUSINESS REPORT - CERTIFICATION STATEMENT**

I, \_\_\_\_\_, \_\_\_\_\_ of  
Name Title

\_\_\_\_\_ certify to best of my knowledge and  
Company

belief that this business meets Emerging Small Business definition as indicated in Article 9 and  
that information contained in this Emerging Small Business Report is true and correct.

\_\_\_\_\_  
Bidder's Signature

\_\_\_\_\_  
Date

**BID FORM**

**BID NO. 108074**

**PROJECT: JOB CENTER ROOF REPLACEMENT  
DANE COUNTY JOB CENTER**

**TO: DANE COUNTY DEPARTMENT OF PUBLIC WORKS, HIGHWAY &  
TRANSPORTATION PROJECT MANAGER  
1919 ALLIANT ENERGY CENTER WAY  
MADISON, WISCONSIN 53713**

**BASE BID - LUMP SUM:**

Dane County is inviting Bids for removal of approximately 80,000 sq. ft. of existing roofing and insulation. Replace with 60 mil. fully adhered EPDM roofing and four (4) in. of polyisocyanurate insulation. The undersigned, having examined the site where the Work is to be executed and having become familiar with local conditions affecting the cost of the Work and having carefully examined the Drawings and Specifications, all other Construction Documents and Addenda thereto prepared by Dane County Department of Public Works, Highway & Transportation hereby agrees to provide all labor, materials, equipment and services necessary for the complete and satisfactory execution of the entire Work, as specified in the Construction Documents, for the Base Bid stipulated sum of:

\_\_\_\_\_ and \_\_\_\_\_ /100 Dollars  
Written Price

\$ \_\_\_\_\_  
Numeric Price

The undersigned further agrees to add the alternates portion of the Work as described, for the following additions to or subtractions from the Base Bid stipulated below. They further agree to honor the alternates bid for 60 days from date of Award of Contract.

**ALTERNATE BID 1 - LUMP SUM:**

Add or subtract price for providing: Substitute White Thermoplastic Polyolefin (TPO) single ply membrane in lieu of the EPDM membrane

\_\_\_\_\_ and \_\_\_\_\_ /100 Dollars  
Written Price

\$ \_\_\_\_\_  
Numeric Price (circle: Add or Deduct)

**ALTERNATE BID 2 - UNIT PRICING:**

Add price for providing unit pricing to replace the parapet batt insulation and vertical parapet sheathing (on the roof side).

Batt and Sheathing replacement:

- Replace Parapet batt insulation: @ \$ \_\_\_\_\_/ln.ft. of wall. = \_\_\_\_\_
- Replace Vertical parapet sheathing( roof side) @ \$ \_\_\_\_\_/ln.ft of wall. = \_\_\_\_\_

Total: \$ \_\_\_\_\_  
Numeric Price (circle: Add or Deduct)

\_\_\_\_\_ and \_\_\_\_\_ /100 Dollars  
Written Price

Receipt of the following addenda and inclusion of their provisions in this Bid is hereby acknowledged:

Addendum No(s). \_\_\_\_\_ through \_\_\_\_\_

Dated \_\_\_\_\_

Dane County Department of Human Services must have this project completed by August 31, 2008. Assuming this Work can be started by June 30, 2008, what dates can you commence and complete this job?

Commencement Date: \_\_\_\_\_ Completion Date: \_\_\_\_\_  
(final, not substantial)

Name of Bidder: \_\_\_\_\_

Address: \_\_\_\_\_

Telephone No.: \_\_\_\_\_ Fax No.: \_\_\_\_\_

Contact Person: \_\_\_\_\_

**SIGNATURE:** \_\_\_\_\_

(Bid is invalid without signature)

**BID CHECK LIST:**

These items **must** be included with Bid or completed **before** bidding

- Bid Form
- Bid Bond
- Fair Labor Practices Certification
- Best Value Qualified Contractor
- Vendor Registration

**FAIR LABOR PRACTICES CERTIFICATION**

The undersigned, for and on behalf of the BIDDER, APPLICANT or PROPOSER named herein, certifies as follows:

A. That he or she is an officer or duly authorized agent of the above-referenced BIDDER, APPLICANT or PROPOSER, which has a submitted a proposal, bid or application for a contract with the county of Dane.

B. That BIDDER, APPLICANT or PROPOSER has (check one):

\_\_\_\_\_ not been found by the National Labor Relations Board (“NLRB”) or the Wisconsin Employment Relations Commission (“WERC”) to have violated any statute or regulation regarding labor standards or relations in the seven years prior to the signature date of this Certification.

\_\_\_\_\_ been found by the National Labor Relations Board (“NLRB”) or the Wisconsin Employment Relations Commission (“WERC”) to have violated any statute or regulation regarding labor standards or relations in the seven years prior to the signature date of this Certification.

\_\_\_\_\_  
Officer or Authorized Agent Signature

\_\_\_\_\_  
Date

\_\_\_\_\_  
Printed or Typed Name and Title

\_\_\_\_\_  
Printed or Typed Business Name

**NOTE:** You can find information regarding the violations described above at: [www.nlrb.gov](http://www.nlrb.gov) and [werc.wi.gov](http://werc.wi.gov).

For reference, Dane County Ordinance 25.11(28)(a) is as follows:

(28) BIDDER RESPONSIBILITY. (a) Any bid, application or proposal for any contract with the county, including public works contracts regulated under chapter 40, shall include a certification indicating whether the bidder has been found by the National Labor Relations Board (NLRB) or the Wisconsin Employment Relations Committee (WERC) to have violated any statute or regulation regarding labor standards or relations within the last seven years. The purchasing manager shall investigate any such finding and make a recommendation to the committee, which shall determine whether the conduct resulting in the finding affects the bidder’s responsibility to perform the contract.

**If you indicated that the NLRB or WERC have found you to have such a violation, you must include copies of any relevant information regarding such violation with your proposal, bid or application.**

**COUNTY OF DANE**

**PUBLIC WORKS CONTRACT**

Contract No. \_\_\_\_\_ Bid No. 108074

Authority: Res. \_\_\_\_\_, 2008-09

**THIS CONTRACT**, made and entered into as of the date by which authorized representatives of both parties have affixed their signatures, by and between the County of Dane (hereafter referred to as "COUNTY") and \_\_\_\_\_ (hereafter, "CONTRACTOR"), and

**WITNESSETH:**

**WHEREAS**, COUNTY, whose address is c/o Associate Public Works Director, 1919 Alliant Energy Center Way, Madison, WI 53713, desires to have CONTRACTOR provide Job Center Roof Replacement at 1819 Aberg Ave. , Madison Wi., including Alternate Bids (if applicable) ("the Project"); and

**WHEREAS**, CONTRACTOR, whose address is \_\_\_\_\_ is able and willing to construct the Project, in accordance with the Construction Documents;

**NOW, THEREFORE**, in consideration of the above premises and the mutual covenants of the parties hereinafter set forth, the receipt and sufficiency of which is acknowledged by each party for itself, COUNTY and CONTRACTOR do agree as follows:

**1.** CONTRACTOR agrees to construct, for the price of \$\_\_\_\_\_ the Project and at the CONTRACTOR'S own proper cost and expense to furnish all materials, supplies, machinery, equipment, tools, superintendence labor, insurance, and other accessories and services necessary to complete the Project in accordance with the conditions and prices stated in the Bid Form, General Conditions of Contract, the drawings which include all maps, plats, plans, and other drawings and printed or written explanatory matter thereof, and the specifications therefore as prepared by Strang, Inc., (hereinafter referred to as "the Architect / Engineer"), and as enumerated in the Project Manual Document Index, all of which are made a part hereof and collectively evidence and constitute the Contract.

**2.** COUNTY agrees to pay the CONTRACTOR in current funds for the performance of the Contract subject to additions and deductions, as provided in the General Conditions of Contract, and to make payments on account thereof as provided in Article entitled, "Payments to Contractor" of the General Conditions of Contract.

**3.** During the term of this Contract, CONTRACTOR agrees to take affirmative action to ensure equal employment opportunities. The CONTRACTOR agrees in accordance with Wisconsin Statute 111.321 and Chapter 19 of the Dane County Code of Ordinances not to discriminate on the basis of age, race, ethnicity, religion, color, gender, disability, marital status, sexual orientation, national origin, cultural differences, ancestry, physical appearance, arrest record or conviction

record, military participation or membership in the national guard, state defense force or any other reserve component of the military forces of the United States, or political beliefs. Such equal opportunity shall include, but not be limited to, the following: employment, upgrading, demotion, transfer, recruitment, advertising, layoff, termination, training, rates of pay, and any other form of compensation. CONTRACTOR agrees to post in conspicuous places, available to all employees and applicants for employment, notices setting forth the provisions of this paragraph.

**4.** CONTRACTOR shall file an Affirmative Action Plan with the Dane County Contract Compliance Officer in accord with Chapter 19 of the Dane County Code of Ordinances. CONTRACTOR must file such plan within fifteen (15) days of the effective date of this Contract. During the term of this Contract CONTRACTOR shall also provide copies of all announcements of employment opportunities to COUNTY'S Contract Compliance Office, and shall report annually the number of persons, by race, ethnicity, gender, and disability status, which apply for employment and, similarly classified, the number hired and number rejected.

**5.** During the term of this Contract, all solicitations for employment placed on CONTRACTOR'S behalf shall include a statement to the effect that CONTRACTOR is an "Equal Opportunity Employer."

**6.** CONTRACTOR agrees to furnish all information and reports required by COUNTY'S Contract Compliance Officer as the same relate to affirmative action and nondiscrimination, which may include any books, records, or accounts deemed appropriate to determine compliance with Chapter 19, Dane County Code of Ordinances, and the provisions of this Contract.

**7.** CONTRACTOR agrees that all persons employed by CONTRACTOR or any subcontractor shall be paid no less than the minimum wage established under Chapter 40, Subchapter II, Dane County Code of Ordinances. CONTRACTOR agrees to abide by and comply with the provisions of Chapter 40, Subchapter II of the Dane County Code of Ordinances, and said Subchapter is fully incorporated herein by reference.

**8.** This Contract is intended to be a Contract solely between the parties hereto and for their benefit only. No part of this Contract shall be construed to add to, supplement, amend, abridge or repeal existing rights, benefits or privileges of any third party or parties including, but not limited to, employees of either of the parties.

**9.** The entire agreement of the parties is contained herein and this Contract supersedes any and all oral agreements and negotiations between the parties relating to the subject matter hereof. The parties expressly agree that the express terms of this Contract shall not be amended in any fashion except in writing, executed by both parties.

**IN WITNESS WHEREOF**, COUNTY and CONTRACTOR, by their respective authorized agents, have caused this Contract and its Schedules to be executed, effective as of the date by which all parties hereto have affixed their respective signatures, as indicated below.

\* \* \* \* \*

**FOR CONTRACTOR:**

\_\_\_\_\_  
Signature Date

\_\_\_\_\_  
Printed or Typed Name and Title

\_\_\_\_\_  
Signature Date

\_\_\_\_\_  
Printed or Typed Name and Title

NOTE: If CONTRACTOR is a corporation, Secretary should attest. In accordance with IRS Regulations, unincorporated entities are required to provide either their Social Security or Employer Number in order to receive payment for services rendered.

**SAMPLE**  
\* \* \* \* \*  
This Contract is not valid or effectual for any purpose until approved by the appropriate authority designated below, and no work is authorized until the CONTRACTOR has been given notice to proceed by COUNTY'S Associate Public Works Director.

**FOR COUNTY:**

\_\_\_\_\_  
Kathleen M. Falk, County Executive Date

\_\_\_\_\_  
Robert Ohlsen, County Clerk Date

THE AMERICAN INSTITUTE OF ARCHITECTS



AIA Document A310

Bid Bond

Bond No.

KNOW ALL MEN BY THESE PRESENTS, that we (Here insert full name and address or legal title of Contractor)

as Principal, hereinafter called the Principal, and (Here insert full name and address or legal title of Surety)

a corporation duly organized under the laws of the State of WI as Surety, hereinafter called the Surety, are held and firmly bound unto (Here insert full name and address or legal title of Owner)

as Obligee, hereinafter called Obligee, in the sum of ( ) Percent of total amount bid Dollars (\$) Percent of attached bid.

For the payment of which sum well and truly to be made, the said Principal and the said Surety, bind ourselves, our heirs, executors, administrators, successors and assigns, jointly and severally, firmly by these presents.

WHEREAS, the Principal has submitted a bid for Project No.: (Here insert full name, address, and description of project)

NOW, THEREFORE, if the Obligee shall accept the bid of the Principal and the Principal shall enter into a Contract with the Obligee in accordance with the terms of such bid, and give such bond or bonds as may be specified in the bidding or Contract Documents with good and sufficient surety for the faithful performance of such Contract and for the prompt payment of labor and material furnished in the prosecution thereof, or in the event of the failure of the Principal to enter such Contract and give such bond or bonds, if the Principal shall pay to the Obligee the difference not to exceed the penalty hereof between the amount specified in said bid and such larger amount for which the Obligee may in good faith contract with another party to perform the Work covered by said bid, then this obligation shall be null and void, otherwise to remain in full force and effect.

Signed and sealed this day of , 20 .

(Principal) (Seal)
(Witness)
(Title)
(Surety) (Seal)
(Witness)
ATTORNEY-IN-FACT



THE AMERICAN INSTITUTE OF ARCHITECTS



Bond No. \_\_\_\_\_

AIA Document A312

**Performance Bond**

Any singular reference to Contractor, Surety, Owner or other party shall be considered plural where applicable.

CONTRACTOR (Name and Address): \_\_\_\_\_

SURETY (Name and Principal Place of Business): \_\_\_\_\_

OWNER (Name and Address): \_\_\_\_\_

CONSTRUCTION CONTRACT  
Date: \_\_\_\_\_  
Amount: \$ \_\_\_\_\_  
Description (Name and Location): \_\_\_\_\_

BOND

Date (Not earlier than Construction Contract Date): \_\_\_\_\_

Amount: \$ \_\_\_\_\_

Modifications to this Bond: \_\_\_\_\_

None

See Page 3

CONTRACTOR AS PRINCIPAL  
COMPANY: \_\_\_\_\_  
(Corporate Seal)

SURETY COMPANY: \_\_\_\_\_  
(Corporate Seal)

Signature: \_\_\_\_\_  
Name and Title:

Signature: \_\_\_\_\_  
Name and Title:

Attorney-in-Fact

(Any additional signatures appear on page 3)

FOR INFORMATION ONLY-Name, Address and Telephone  
AGENT OR BROKER: \_\_\_\_\_

OWNER'S REPRESENTATIVE (Architect,  
Engineer or other party): \_\_\_\_\_

1. The Contractor and the Surety, jointly and severally, bind themselves, their heirs, executors, administrators, successors, and assigns to the Owner for the performance of the Construction Contract, which is incorporated herein by reference.

2. If the Contractor performs the Construction Contract, the Surety and the Contractor shall have no obligation under this Bond, except to participate in conferences as provided in Subparagraph 3.1.

3. If there is no Owner Default, the Surety's obligation under this Bond shall arise after:

3.1 The Owner has notified the Contractor and the Surety at its address described in Paragraph 10 below that the Owner is considering declaring a Contractor Default and has requested and attempted to arrange a conference with the Contractor and the Surety to be held not later than fifteen days after receipt of such notice to discuss methods of performing the Construction Contract. If the Owner, the Contractor and the Surety agree, the Contractor shall be allowed a reasonable time to perform the Construction Contract, but such an agreement shall not waive the Owner's right, if any, subsequently to declare a Contractor Default; and

3.2 The Owner has declared a Contractor Default and formally terminated the Contractor's right to complete the contract. Such Contractor Default shall not be declared earlier than twenty days after the Contractor and the Surety have received notice as provided in Subparagraph 3.1; and

3.3 The Owner has agreed to pay the Balance of the Contract Price to the Surety in accordance with the terms of the Construction Contract or to a contractor selected to perform the Construction Contract in accordance with the terms of the contract with the Owner.

4. When the Owner has satisfied the conditions of Paragraph 3, the Surety shall promptly and at the Surety's expense take one of the following actions:

4.1 Arrange for the Contractor, with consent of the Owner, to perform and complete the Construction Contract; or

4.2 Undertake to perform and complete the Construction Contract itself, through its agents or through independent contractors; or

4.3 Obtain bids or negotiated proposals from qualified contractors acceptable to the Owner for a contract for performance and completion of the Construction Contract, arrange for a contract to be prepared for execution by the Owner and the contractor selected with the Owner's concurrence, to be secured with performance and payment bonds executed by a qualified surety equivalent to the bonds issued on the Construction Contract, and pay to the Owner the amount of damages as described in Paragraph 6 in excess of the Balance of the Contract Price incurred by the Owner resulting from the Contractor's default; or

4.4 Waive its rights to perform and complete, arrange for completion, or obtain a new contractor and with reasonable promptness under the circumstances:

1. After investigation, determine the amount for

which it may be liable to the Owner and, as soon as practicable after the amount is determined, tender payment therefor to the Owner; or

2. Deny liability in whole or in part and notify the Owner citing reasons therefor.

5. If the Surety does not proceed as provided in Paragraph 4 with reasonable promptness, the Surety shall be deemed to be in default on this Bond fifteen days after receipt of an additional written notice from the Owner to the Surety demanding that the Surety perform its obligations under this Bond, and the Owner shall be entitled to enforce any remedy available to the Owner. If the Surety proceeds as provided in Subparagraph 4.4, and the Owner refuses the payment tendered or the Surety has denied liability, in whole or in part, without further notice the Owner shall be entitled to enforce any remedy available to the Owner.

6. After the Owner has terminated the Contractor's right to complete the Construction Contract, and if the Surety elects to act under Subparagraph 4.1, 4.2, or 4.3 above, then the responsibilities of the Surety to the Owner shall not be greater than those of the Contractor under the Construction Contract, and the responsibilities of the Owner to the Surety shall not be greater than those of the Owner under the Construction Contract. To the limit of the amount of this Bond, but subject to commitment by the Owner of the Balance of the Contract Price to mitigation of costs and damages on the Construction Contract, the Surety is obligated without duplication for:

6.1 The responsibilities of the Contractor for correction of defective work and completion of the Construction Contract;

6.2 Additional legal, design professional and delay costs resulting from the Contractor's Default, and resulting from the actions or failure to act of the Surety under Paragraph 4; and

6.3 Liquidated damages, or if no liquidated damages are specified in the Construction Contract, actual damages caused by delayed performance or non-performance of the Contractor.

7. The Surety shall not be liable to the Owner or others for obligations of the Contractor that are unrelated to the Construction Contract, and the Balance of the Contract Price shall not be reduced or set off on account of any such unrelated obligations. No right of action shall accrue on this Bond to any person or entity other than the Owner or its heirs, executors, administrators, or successors.

8. The Surety hereby waives notice of any change, including changes of time, to the Construction Contract or to related subcontracts, purchase orders and other obligations.

9. Any proceeding, legal or equitable, under this Bond may be instituted in any court of competent jurisdiction in the location in which the work or part of the work is located and shall be instituted within two years after Contractor Default or within two years after the Contractor ceased working or within two years after the Surety refuses or fails to perform its obligations under this Bond, whichever occurs first. If the provisions of this Paragraph are void or prohibited by law, the minimum period of limitation available to sureties as a defense in the jurisdiction of the suit shall be applicable.

10. Notice to the Surety, the Owner or the Contractor shall be mailed or delivered to the address shown on the signature page.

11. When this Bond has been furnished to comply with a statutory or other legal requirement in the location where the construction was to be performed, any provision in this Bond conflicting with said statutory or legal requirement shall be deemed deleted here from and provisions conforming to such statutory or other legal requirement shall be deemed incorporated herein. The intent is that this Bond shall be construed as a statutory bond and not as a common law bond.

**12 DEFINITIONS**

12.1 Balance of the Contract Price: The total amount payable by the Owner to the Contractor under the Construction Contract after all proper adjustments have been made, including allowance to the Contractor of any amounts received or to be received by the Owner in settlement of insurance or other

claims for damages to which the Contractor is entitled, reduced by all valid and proper payments made to or on behalf of the Contractor under the Construction Contract.

12.2 Construction Contract: The agreement between the Owner and the Contractor identified on the signature page, including all Contract Documents and changes thereto.

12.3 Contractor Default: Failure of the Contractor, which has neither been remedied nor waived, to perform or otherwise to comply with the terms of the Construction Contract.

12.4 Owner Default: Failure of the Owner, which has neither been remedied nor waived, to pay the Contractor as required by the Construction Contract or to perform and complete or comply with the other terms thereof.

**MODIFICATIONS TO THIS BOND ARE AS FOLLOWS:**

SAMPLE

(Space is provided below for additional signatures of added parties, other than those appearing on the cover page.)

CONTRACTOR AS PRINCIPAL  
Company: (Corporate Seal)

SURETY  
Company: (Corporate Seal)

Signature: \_\_\_\_\_  
Name and Title:  
Address:

Signature: \_\_\_\_\_  
Name and Title:  
Address:

THE AMERICAN INSTITUTE OF ARCHITECTS



Bond No. \_\_\_\_\_

AIA Document A312

Payment Bond

Any singular reference to Contractor, Surety, Owner or other party shall be considered plural where applicable.

CONTRACTOR (Name and Address):

SURETY (Name and Principal Place of Business):

OWNER (Name and Address):

CONSTRUCTION CONTRACT  
Date:  
Amount: \$  
Description (Name and Location):

BOND

Date (Not earlier than Construction Contract Date):

Amount: \$

Modifications to this Bond:

None

See Page 6

CONTRACTOR AS PRINCIPAL  
COMPANY: (Corporate Seal)

SURETY COMPANY:  
(Corporate Seal)

Signature: \_\_\_\_\_  
Name and Title:

Signature: \_\_\_\_\_  
Name and Title:  
Attorney-in-Fact

(Any additional signatures appear on page 6)

FOR INFORMATION ONLY-Name, Address and Telephone  
AGENT OR BROKER:

OWNER'S REPRESENTATIVE (Architect,  
Engineer or other party):

1. The Contractor and the Surety, jointly and severally, bind themselves, their heirs, executors, administrators, successors, and assigns to the Owner to pay for labor, materials and equipment furnished for use in the performance of the Construction Contract, which is incorporated herein by reference.
2. With respect to the Owner, this obligation shall be null and void if the Contractor:
  - 2.1 Promptly makes payment, directly, or indirectly, for all sums due Claimants, and
  - 2.2 Defends, indemnifies and holds harmless the Owner from claims, demands, liens or suits by any person or entity whose claim, demand, lien or suit is for the payment for labor, materials, or equipment furnished for use in the performance of the Construction Contract, provided the Owner has promptly notified the Contractor and the Surety (at the address described in Paragraph 12) of any claims, demands, liens, or suits and tendered defense of such claims, demands, liens or suits to the Contractor and the Surety, and provided there is no Owner Default.
3. With respect to Claimants, this obligation shall be null and void if the Contractor promptly makes payment, directly or indirectly, for all sums due.
4. The Surety shall have no obligation to Claimants under this Bond until:
  - 4.1 Claimants who are employed by or have a direct contract with the Contractor have given notice to the Surety (at the address described in Paragraph 12) and sent a copy, or notice thereof, to the Owner, stating that a claim is being made under this Bond and, with substantial accuracy, the amount of the claim.
  - 4.2 Claimants who do not have a direct contract with the Contractor:
    1. Have furnished written notice to the Contractor and sent a copy, or notice thereof, to the Owner, within 90 days after having last performed labor or last furnished materials or equipment included in the claim stating, with substantial accuracy, the amount of the claim and the name of the party to whom the materials were furnished or supplied or for whom the labor was done or performed; and
    2. Have either received a rejection in whole or in part from the Contractor, or not received within 30 days of furnishing the above notice any communication from the Contractor by which the Contractor has indicated the claim will be paid directly or indirectly; and
    3. Not having been paid within the above 30 days, have sent a written notice to the Surety (at the address described in Paragraph 12) and sent a copy, or notice thereof, to the Owner, stating that a claim is being made under this Bond and enclosing a copy of the previous written notice furnished to the Contractor.
5. If a notice required by Paragraph 4 is given by the Owner to the Contractor or to the Surety, that is sufficient compliance.
6. When the Claimant has satisfied the conditions of Paragraph 4, the Surety shall promptly and at the Surety's expense take the following actions:
  - 6.1 Send an answer to the Claimant, with a copy to the Owner, within 45 days after receipt of the claim, stating the amounts that are undisputed and the basis for challenging any amounts that are disputed.
  - 6.2 Pay or arrange for payment of any undisputed amounts.
7. The Surety's total obligation shall not exceed the amount of this Bond, and the amount of this Bond shall be credited for any payments made in good faith by the Surety.
8. Amounts owed by the Owner to the Contractor under the Construction Contract shall be used for the performance of the Construction Contract and to satisfy claims, if any, under any Construction Performance Bond. By the Contractor furnishing and the Owner accepting this Bond, they agree that all funds earned by the Contractor in the performance of the Construction Contract are dedicated to satisfy obligations of the Contractor and the Surety under this Bond, subject to the Owner's priority to use the funds for the completion of the work.
9. The Surety shall not be liable to the Owner, Claimants or others for obligations of the Contractor that are unrelated to the Construction Contract. The Owner shall not be liable for payment of any costs or expenses of any Claimant under this Bond, and shall have under this Bond no obligations to make payments to, give notices on behalf of, or otherwise have obligations to Claimants under this Bond.
10. The Surety hereby waives notice of any change, including changes of time, to the Construction Contract or to related subcontracts, purchase orders and other obligations.
11. No suit or action shall be commenced by a Claimant under this Bond other than in a court of competent jurisdiction in the location in which the work or part of the work is located or after the expiration of one year from the date (1) on which the Claimant gave the notice required by Subparagraph 4.1 or Clause 4.2.3, or (2) on which the last labor or service was performed by anyone or the last materials or equipment were furnished by anyone under the Construction Contract, whichever of (1) or (2) first occurs. If the provisions of this Paragraph are void or prohibited by law, the minimum period of limitation available to sureties as a defense in the jurisdiction of the suit shall be applicable.
12. Notice to the Surety, the Owner or the Contractor shall be mailed or delivered to the address shown on the signature page. Actual receipt of notice by Surety, the Owner or the Contractor, however accomplished, shall be sufficient compliance as of the date received at the address shown on the signature page.
13. When this Bond has been furnished to comply with a statutory or other legal requirement in the location where the construction was to be performed, any provision in this Bond conflicting with said statutory or legal requirement shall be deemed deleted herefrom and provisions conforming to such statutory or other legal requirement shall be deemed incorporated herein. The intent is that this Bond shall be construed as a statutory bond and not as a common law bond.
14. Upon request by any person or entity appearing to be a potential beneficiary of this Bond, the Contractor

shall promptly furnish a copy of this Bond or shall permit a copy to be made.

**15. DEFINITIONS**

**15.1 Claimant:** An individual or entity having a direct contract with the Contractor or with a subcontractor of the Contractor to furnish labor, materials or equipment for use in the performance of the Contract. The intent of this Bond shall be to include without limitation in the terms "labor, materials or equipment" that part of water, gas, power, light, heat, oil, gasoline, telephone service or rental equipment used in the Construction Contract, architectural and engineering services required for performance of the work of the Contractor and the Contractor's

subcontractors, and all other items for which a mechanic's lien may be asserted in the jurisdiction where the labor, materials or equipment were furnished.

**15.2 Construction Contract:** The agreement between the Owner and the Contractor identified on the signature page, including all Contract Documents and changes thereto.

**15.3 Owner Default:** Failure of the Owner, which has neither been remedied nor waived, to pay the Contractor as required by the Construction Contract or to perform and complete or comply with the other terms thereof.

**MODIFICATIONS TO THIS BOND ARE AS FOLLOWS:**

SAMPLE

(Space is provided below for additional signatures of added parties, other than those appearing on the cover page.)

CONTRACTOR AS PRINCIPAL  
Company: (Corporate Seal)

SURETY  
Company: (Corporate Seal)

Signature: \_\_\_\_\_  
Name and Title:  
Address:

Signature: \_\_\_\_\_  
Name and Title:  
Address:

## GENERAL CONDITIONS OF CONTRACT

### TABLE OF CONTENTS

1. CONSTRUCTION DOCUMENTS .....	2
2. DEFINITIONS .....	2
3. ADDITIONAL INSTRUCTIONS AND DRAWINGS .....	2
4. SHOP DRAWINGS, PRODUCT DATA AND SAMPLES .....	2
5. CUTTING AND PATCHING .....	3
6. CLEANING UP.....	4
7. USE OF SITE .....	4
8. MATERIALS AND WORKMANSHIP .....	5
9. CONTRACTOR'S TITLE TO MATERIALS .....	5
10. "OR EQUAL" CLAUSE.....	5
11. PATENTS AND ROYALTIES .....	6
12. SURVEYS, PERMITS, REGULATIONS AND TAXES .....	7
13. CONTRACTOR'S OBLIGATIONS AND SUPERINTENDENCE.....	7
14. WEATHER CONDITIONS .....	8
15. PROTECTION OF WORK AND PROPERTY.....	8
16. INSPECTION AND TESTING OF MATERIALS .....	8
17. REPORTS, RECORDS AND DATA .....	9
18. CHANGES IN THE WORK .....	9
19. EXTRAS.....	10
20. TIME FOR COMPLETION.....	10
21. CORRECTION OF WORK .....	10
22. SUBSURFACE CONDITIONS FOUND DIFFERENT.....	11
23. RIGHT OF THE DEPARTMENT TO TERMINATE CONTRACT .....	11
24. CONSTRUCTION SCHEDULE AND PERIODIC ESTIMATES .....	11
25. PAYMENTS TO CONTRACTOR.....	12
26. WITHHOLDING OF PAYMENTS.....	13
27. ACCEPTANCE OF FINAL PAYMENT AS RELEASE .....	14
28. PAYMENTS BY CONTRACTOR.....	14
29. CONTRACT SECURITY .....	14
30. ASSIGNMENTS .....	15
31. MUTUAL RESPONSIBILITY OF CONTRACTORS.....	15
32. SEPARATE CONTRACTS .....	15
33. SUBCONTRACTS.....	15
34. PUBLIC WORKS PROJECT ENGINEER'S AUTHORITY .....	16
35. ARCHITECT / ENGINEER'S AUTHORITY.....	16
36. STATED ALLOWANCES.....	17
37. ESTIMATES OF QUANTITIES .....	17
38. LANDS AND RIGHTS-OF-WAY.....	17
39. GENERAL GUARANTEE .....	17
40. CONFLICTING CONDITIONS .....	18
41. NOTICE AND SERVICE THEREOF .....	18
42. PROTECTION OF LIVES AND HEALTH.....	18
43. AFFIRMATIVE ACTION PROVISION AND MINORITY / WOMEN / DISADVANTAGED BUSINESS ENTERPRISES .....	18
44. USE AND OCCUPANCY PRIOR TO ACCEPTANCE.....	19
45. MINIMUM WAGES .....	20
46. CLAIMS .....	21
47. ANTITRUST AGREEMENT.....	21
48. INSURANCE .....	21
49. WISCONSIN LAW CONTROLLING .....	23

## **1. CONSTRUCTION DOCUMENTS**

- A. Construction Documents, listed in Table of Contents of this Specification volume shall form a part of this Contract and provisions of Construction Documents shall be as binding upon parties as if they were fully set forth in Contract itself.
- B. These shall also be considered as part of Construction Documents: Addenda, including additions and modifications incorporated in such addenda before execution of Contract; requests for information; construction bulletins; change orders; and written interpretations by Architect / Engineer or Public Works Project Engineer that are made after execution of Contract.
- C. Construction Documents are complementary, and what is required by one shall be as binding as if required by all. Intent of Construction Documents is to include all labor, materials and equipment necessary for proper execution of the Work.

## **2. DEFINITIONS**

- A. These terms as used in this Contract are respectively defined as follows:
  - 1. All uses of term "County" in Construction Documents shall mean Dane County.
  - 2. All uses of term "Department" in Construction Documents shall mean Department of Public Works, Highway & Transportation, which is a unit of Dane County government. Department is County agency overseeing Contract with Contractor.
  - 3. Public Works Project Engineer is appointed by and responsible to Department. Public Works Project Engineer has authority to act on behalf of Department and will sign change orders, payment requests and other administrative matters related to projects.
  - 4. Public Works Project Engineer is responsible for supervision, administration and management of field operations involved in construction phase of this Work.
  - 5. Term "Work" includes all labor, equipment and materials necessary to produce project required by Construction Documents.
  - 6. Term "Substantial Completion" is date when project or specified area of project is certified by Architect / Engineer that construction is sufficiently completed, in accordance with Construction Documents, and as modified by any subsequent changes agreed to by parties, so that County may occupy project or specified area of project for use for which it was intended subject to permit approval for occupancy.
  - 7. Contractor is a person, firm, or corporation with whom County makes Contract. Though multiple contracts may be involved, Construction Documents treat them throughout as if each were of singular number.

## **3. ADDITIONAL INSTRUCTIONS AND DRAWINGS**

- A. Contractor may be furnished additional instructions and detail drawings as necessary to carry out the Work included in Contract. Additional drawings and instructions thus supplied to Contractor will coordinate with Construction Documents and will be so prepared that they can be reasonably interpreted as part thereof. Contractor shall carry out the Work in accordance with additional detail drawings and instructions.

## **4. SHOP DRAWINGS, PRODUCT DATA AND SAMPLES**



- A. Unless otherwise specified, Contractor shall submit three (3) copies of all Shop Drawings for each submission, until receiving final approval. After final approval, provide five (5) additional copies for distribution and such other copies as may be required.
- B. Contractor shall submit, on an on-going basis and as directed, Product Data such as brochures that shall contain catalog cuts and specifications of all furnished mechanical and electrical equipment. After Architect / Engineer's approval, one (1) copy shall remain in Architect / Engineer's file, one (1) kept at Department's office and one (1) kept at job site by Contractor for reference purposes.
- C. Samples shall consist of physical examples furnished by Contractor in sufficient size and quantity to illustrate materials, equipment or workmanship, and to establish standards to compare the Work.
  - 1. Submit Samples in sufficient quantity (minimum of two (2)) to permit Architect / Engineer to make all necessary tests and of adequate size showing quality, type, color range, finish, and texture. Label each Sample stating material, type, color, thickness, size, project name, and Contractor's name.
  - 2. Submit transmittal letter requesting approval, and prepay transportation charges to Architect / Engineer's office on samples forwarded.
  - 3. Materials installed shall match approved Samples.
- D. Contractor shall review Shop Drawings and place their dated stamp thereon to evidence their review and approval and shall submit with reasonable promptness and in orderly sequence to cause no delay in the Work or in work of any other contractor. At time of submission, Contractor shall inform Architect / Engineer in writing of any deviation in Shop Drawings or Samples from requirements of Construction Documents. Architect / Engineer will not consider partial lists.
- E. Architect / Engineer will review and approve or reject Shop Drawings with reasonable promptness to cause no delay. Architect / Engineer's approval shall not relieve Contractor from responsibility for errors or omission in Shop Drawings.
- F. Contractor shall not commence any work requiring Shop Drawing, Product Data or Sample submission until Architect / Engineer has approved submission. All such work shall be in accordance with approved Shop Drawings, Product Data and Samples.
- G. Contractor shall keep on site of the Work, an approved or conformed copy of Shop Drawings and shall at all time give Department access thereto.
- H. By stamping and submitting Shop Drawings, Product Data and Samples, Contractor thereby represents that he or she has or will determine and verify all field measurements, field construction criteria, materials, catalog numbers, and similar data and that he or she has checked and coordinated each Shop Drawing, Product Data and Sample with requirements of the Work and of Construction Documents. Architect / Engineer shall return without examination, Shop Drawings, Product Data and Samples not so noted.
- I. All Shop Drawings from any one Contractor should be numbered consecutively and on cover sheet shall bear name and location of project, name of Contractor, date of submittal and date of each correction or revision and associated Specification section and page number.

## **5. CUTTING AND PATCHING**

- A. Contractor shall be responsible for all cutting, fitting or patching required to complete the Work or to make its parts fit together properly.
- B. Contractor shall not damage or endanger a portion of the Work or fully or partially completed construction of County or separate contractors by cutting, patching or otherwise altering such construction, or by excavation. Contractor shall not cut or otherwise alter such construction by County or a separate contractor except with written consent of County and of such separate contractor; such consent shall not be unreasonably withheld. Contractor shall not withhold unreasonably from County or a separate contractor, Contractor's consent to cutting or otherwise altering the Work.

## **6. CLEANING UP**

- A. Contractor shall keep premises and surrounding area free from accumulation of waste materials or rubbish caused by operations under Contract. Contractor shall remove from and about the Work waste materials, rubbish, Contractor's tools, construction equipment, machinery, and surplus materials at completion of the Work. Contractor shall maintain streets and sidewalks around the Work site in a clean condition. Contractor shall remove all spillage and prevent tracking of spillage arising from performance of the Work, into, out of, and within the Work site. Contractor shall establish a regular maintenance program of sweeping, vacuuming and / or hosing to minimize accumulation of dirt and dust upon such areas.
- B. If Contractor fails to clean up as directed in Construction Documents, County may do so and shall charge Contractor cost thereof.
- C. Contractor shall be responsible for broken windows and glass, and at completion of the Work shall replace such damaged or broken windows and glass. After replacing damaged or broken windows and glass, Contractor shall remove all labels, wash and polish both sides of all windows and glass.
- D. In addition to general cleaning (sweeping, vacuuming and / or hosing, as is appropriate to work surface), Contractor shall perform following final cleaning for all trades at completion of the Work:
  - 1. Remove temporary protections;
  - 2. Remove marks, stains, fingerprints and other soil or dirt from painted, decorated and finished woodwork and wall surfaces;
  - 3. Remove spots, plaster, soil and paint from ceramic tile, marble and other finished materials, and wash or wipe clean;
  - 4. Clean fixtures, cabinet work and equipment, removing stains, paint, dirt and dust, and leave same in undamaged, new condition;
  - 5. Clean aluminum in accordance with recommendations of manufacturer; and
  - 6. Clean resilient floors thoroughly with a well-rinsed mop containing only enough moisture to clean off any surface dirt or dust and buff dry by machine to bring surfaces to sheen.

## **7. USE OF SITE**

- A. Contractor shall provide County and Architect / Engineer access to the Work under all circumstances.
- B. Contractor shall confine operations at site to areas permitted by County, law, ordinance, permits and Construction Documents and shall not unreasonably encumber site with materials

or equipment. Contractor shall assure free, convenient, unencumbered, direct and safe access to all properties adjacent to the Work for County, its employees, invitees and guests.

## **8. MATERIALS AND WORKMANSHIP**

- A. Contractor shall perform all work and furnish all supplies and materials, machinery, equipment, facilities and means, necessary to complete the Work required by this Contract, within time specified, in accordance with provisions of Construction Documents.
- B. All equipment and materials incorporated in the Work covered by this Contract are to be new; use recycled and / or recovered materials to extent that such use is technically and economically feasible. Recovered materials are products recovered from solid waste in form identical to original form for use that is same as, or similar to original use. Recycled materials are products manufactured from solid waste.
- C. If requested, Contractor shall furnish satisfactory evidence as to kind and quality of construction materials proposed or used. Contractor shall furnish to Architect / Engineer, for approval, manufacturer name and model, performance capacities and other pertinent information of machinery, mechanical, electrical or other types of equipment, which Contractor plans to install.
- D. If not otherwise provided, materials and labor called for in this Contract shall be provided and performed in accordance with established practice and standards recognized by Architects, Engineers, Department, and construction industry.
- E. Reference to "Standard" specifications of any association or manufacturer, or codes of County authorities, intends most recent printed edition or catalog in effect on date that corresponds with date of Construction Documents.
- F. Whenever reference is made in Specifications that work shall be "performed", "applied", in accordance with "manufacturer's directions or instructions", Contractor to whom those instructions are directed shall furnish three (3) printed copies of such instructions to Architect / Engineer before execution of the Work.

## **9. CONTRACTOR'S TITLE TO MATERIALS**

- A. Contractor or any subcontractor shall not purchase materials or supplies for the Work subject to any chattel mortgage or under conditional sale contract or other agreement by which seller retains interest. Contractor warrants that all materials and supplies used in the Work are free from all liens, claims or encumbrances and Contractor has good title to them.

## **10. "OR EQUAL" CLAUSE**

- A. Whenever equipment or materials are identified on Drawings or in Specifications by reference to manufacturer's or vendor's name, trade name, catalog number, and other identifying information, it is intended to establish a standard; and any equipment or material of other manufacturers and vendors which will perform adequately duties imposed by general design will be considered equally accepted provided equipment or material so proposed is, in opinion of Architect / Engineer, of equal substance and function. Architect / Engineer and Department shall provide written approval before Contractor may purchase or install it.

- B. Equipment or materials of manufacturers, other than those named, may be used only upon following conditions:
1. That, in opinion of Architect / Engineer and Department, proposed material or equipment item is fully equal or superior (in design, materials, construction, workmanship, performance, finish, etc.) to named item. No compromise in quality level, however small, is acceptable.
  2. That, in substituting materials or equipment, Contractor assumes responsibility for any changes in system or for modifications required in adjacent or related work to accommodate such substitution despite Architect / Engineer's and Department's approval, and all costs growing out of approval of "or equal" items shall be responsibility of Contractor. No extra costs resulting from such approval shall become responsibility of Department, Architect / Engineer or any other separate Contractor.
  3. It shall be understood that use of materials or equipment other than those specified, or approved equal by Architect / Engineer and Department, shall constitute a violation of Contract, and that Architect / Engineer and Department shall have right to require removal of such materials or equipment and their replacement with specified materials or equipment at Contractor's expense.
  4. Product and manufacturer named first in Specifications or on information shown on Drawings is basis of selection of manufactured items and equipment, particularly mechanical equipment. In using other than first named products or manufacturers, including those specified as additionally approved or acceptable, Contractor assumes responsibility for any changes in system and for modifications in any work required to accommodate them. Architect / Engineer's approval of such additionally acceptable products or manufacturers, either in Specifications or in an Addendum, does not relieve Contractor from obligation to coordinate such optional products with other Contractors, whose work may be affected by them, and to pay all additional costs resulting from their inclusion into the Work. Contractor's liability shall include payment of Architect / Engineer's fees for any additional services made necessary by or directly connected to such product changes. No extra costs resulting from such changes shall become responsibility of Department, Architect / Engineer or any other separate Contractor.
- C. No request for approval of "or equal" materials will be entertained except from Contractor. Identify any request for substitution as substitution on Contractor's letter of transmittal and give reasons for substitution. Department may in its sole discretion allow substitutions of materials.

## **11. PATENTS AND ROYALTIES**

- A. If Contractor uses any design, device or material covered by letters, patent or copyright, it is mutually agreed and understood, that, without exception, contract prices shall include all royalties or costs arising from use of such design, device or materials, in any way involved in the Work.
- B. Contractor shall indemnify and save harmless County from any and all claims for infringement by reason of use of such patent or copyright in connection with the Work agreed to be performed under this Contract, and shall indemnify County for any cost, expense or damage which it may be obliged to pay by reason of such infringement at any time during prosecution of the Work or after completion of the Work.

## **12. SURVEYS, PERMITS, REGULATIONS AND TAXES**

- A. Department will furnish to Contractor all site, topography and property surveys necessary for execution of the Work.
- B. Contractor shall procure all permits, licenses and approvals necessary for execution of this Contract.
- C. Contractor shall give all notices and comply with all State of Wisconsin, Federal and local laws, codes, rules and regulations relating to performance of the Work, protection of adjacent property, and maintenance of passageways, guard fences or other protective facilities.
- D. Contractor shall pay all Sales, Consumer, Use and other similar taxes required by law.
- E. Contractor shall promptly notify Architect / Engineer of any variances of Drawings or Specifications with that of any State of Wisconsin, federal or local law, code, rule or regulation. Upon such notification, Architect / Engineer will require correction of variance to comply with applicable law, code, rule or regulation at no additional cost to Contractor.
- F. Work under this Contract shall comply with all applicable State of Wisconsin, Federal and local laws, codes and regulations.
- G. Contractor shall pay charges for water, sewer and other utility connections made by municipalities where required by Specifications.

## **13. CONTRACTOR'S OBLIGATIONS AND SUPERINTENDENCE**

- A. Contractor shall provide and pay for all materials, labor, tools, equipment, transportation and superintendence necessary to execute, complete and deliver the Work within specified time. Contractor agrees to secure at their own expense all personnel necessary to carry out the Work. Such personnel shall not be deemed County employees nor shall they have or be deemed to have any direct contractual relationship with County.
- B. Performance of any work necessary after regular working hours, on Sundays or Legal Holidays shall be without additional expense to County. Performance of any work at site at other than normal working hours must be coordinated with Public Works Project Engineer.
- C. Contractor shall furnish, erect, maintain and remove such temporary works as may be required.
- D. Contractor shall observe, comply with, and be subject to all terms, conditions, requirements and limitations of Construction Documents.
- E. At the Work site, Contractor shall give personal superintendence to the Work or shall employ a construction superintendent or foreman, experienced in character of work covered by Contract, who shall have full authority to act for Contractor. Understand that such superintendent or foreman shall be acceptable to Architect / Engineer and Department.
- F. Remove from project or take other corrective action upon notice from Architect / Engineer or Department for Contractor's employees whose work is considered by Architect / Engineer or Department to be unsatisfactory, careless, incompetent, unskilled or otherwise objectionable.

- G. Contractor and subcontractors shall be required to conform to Labor Laws of State of Wisconsin and various acts amendatory and supplementary thereto and to other laws, ordinances and legal requirements applicable to the Work.
- H. Presence and observation of the Work by Architect / Engineer or Public Works Project Engineer shall not relieve Contractor of any obligations.

#### **14. WEATHER CONDITIONS**

- A. In event of temporary suspension of work, or during inclement weather, or whenever Architect / Engineer shall direct, Contractor shall, and shall cause subcontractors to protect carefully all work and materials against damage or injury from weather. If, in opinion of Architect / Engineer or Department, any work or materials that have been damaged or injured due to failure on part of Contractor or any subcontractors so to protect the Work, such materials shall be removed and replaced at expense of Contractor.

#### **15. PROTECTION OF WORK AND PROPERTY**

- A. Contractor shall at all times safely guard County's property from injury or loss in connection with this Contract. Contractor shall at all times safely guard and protect the Work, and adjacent property, from damage. Contractor shall replace or make good any such damage, loss or injury unless such be caused directly by errors contained in Contract, or by County, or County's duly authorized representative.
- B. Contractor may act in a diligent manner, without previous instructions from Architect / Engineer and / or Department, in an emergency that threatens loss or injury of property, or safety of life. Contractor shall notify Architect / Engineer and / or Department immediately thereafter. Promptly submit any claim for compensation by Contractor due to such extra work to Architect / Engineer and / or Department for approval as provided for in Article 18 herein.

#### **16. INSPECTION AND TESTING OF MATERIALS**

- A. Authorized representatives and agents of County government shall have access at all times to the Work wherever it is in preparation or progress and Contractor shall provide facilities for such access and for inspection.
- B. Should it be considered necessary or advisable at any time before final acceptance of the Work to make an examination of work already completed, by removing or tearing out same, Contractor shall upon request, promptly furnish all necessary facilities, labor and materials. If such work is found to be defective in any aspect, due to fault of Contractor or subcontractors thereof, Contractor shall assume all expenses of such examination and of satisfactory reconstruction. Contractor will be reimbursed for such examination and replacement in accordance with Article 18 - A.3., of these General Conditions of Contract if such work is found to meet requirements of Contract.
- C. If Specifications, Architect / Engineer's, or Public Works Project Engineer's instructions require any work to be specially tested or approved, Contractor shall give Architect / Engineer and Public Works Project Engineer timely notice of its readiness for testing or inspection. Test all materials and equipment requiring testing in accordance with accepted or specified standards, as applicable. Architect / Engineer shall recommend laboratory or inspection agency and Department will select and pay for all initial laboratory inspection services.

Should retesting be required, due to failure of initial testing, cost of such retesting shall be borne by Contractor.

- D. Cost of any testing performed by manufacturers or Contractor for substantiating acceptability of proposed substitution of materials and equipment, or necessary conformance testing in conjunction with manufacturing processes or factory assemblage, shall be borne by Contractor or manufacturer responsible.

## **17. REPORTS, RECORDS AND DATA**

- A. Contractor shall submit to Architect / Engineer and Public Works Project Engineer such schedule of quantities and costs, progress schedules, payrolls, reports, estimates, invoices, records and other data as either may request concerning work performed or to be performed under this Contract.

## **18. CHANGES IN THE WORK**

- A. Make no changes, except in cases of emergency, in the Work covered by approved Construction Documents without having prior written approval of Department. Charges or credits for the Work covered by approved change shall be determined by one of these methods:
1. Unit bid prices previously approved.
  2. An agreed lump sum based on actual cost of:
    - a) Labor, including foremen, and all fringe benefits that are associated with their wages.
    - b) Materials entering permanently into the Work.
    - c) Ownership or rental cost of construction tools and equipment during time of use on extra work.
    - d) Power and consumable supplies for operation of power equipment.
    - e) Workmen's Compensation Insurance, Contractor's Public Liability and Property Damage Insurance, and Comprehensive Automobile Liability Insurance.
    - f) Social Security and old age and unemployment contributions.
    - g) Add to cost under (2), fixed fee to be agreed upon, but not to exceed fifteen percent (15%) of actual cost of work performed with their own labor force. Fee shall be compensation to cover cost of supervision, overhead, bond, profit and any other general expense.
    - h) On that portion of the Work under (2) done under subcontract, Contractor may include not over seven and one-half percent (7½%) for supervision, overhead, bond, profit and any other general expense.
    - i) Department may require correct amount of costs with supporting vouchers; Contractor shall keep and present in such form as directed.
  3. Cost-plus work, with a not-to-exceed dollar limit, based on actual cost of:
    - a) Labor, including foremen, and all fringe benefits that are associated with their wages.
    - b) Materials entering permanently into the Work.
    - c) Ownership or rental cost of construction tools and equipment during time of use on extra work. Rental cost cannot exceed fifty percent (50%) replacement value of rented equipment.
    - d) Power and consumable supplies for operation of power equipment.
    - e) Workmen's Compensation Insurance, Contractor's Public Liability and Property Damage Insurance, and Comprehensive Automobile Liability Insurance.
    - f) Social Security and old age and unemployment contributions.
    - g) To cost under (3), there shall be added a fixed fee to be agreed upon but not to exceed fifteen percent (15%) of actual cost of work performed with their own labor force. Fee

shall be compensation to cover cost of supervision, overhead, bond, profit, and any other general expense.

- h) On that portion of the Work under (3) done under subcontract, Contractor may include not over seven and one-half percent (7½%) for supervision, overhead, bond, profit, and any other general expense.
  - i) Contractor shall keep and present, in such form as directed, correct amount of cost together with such supporting vouchers as may be required by Department.
- B. If Contractor claims that by any instructions given by Architect / Engineer, Department, by drawings or otherwise, regarding performance of the Work or furnishing of material under Contract, involves extra cost, Contractor shall give Department written notice of cost thereof within two (2) weeks after receipt of such instructions and in any event before proceeding to execute work, unless delay in executing work would endanger life or property.
- C. No claim for extra work or cost shall be allowed unless it was done in pursuance of written Change Order from Architect / Engineer and approved by Department, as previously mentioned, and claim presented with payment request submitted after changed or extra work is completed.
- D. Negotiation of cost for a change in the Work shall not be cause for Contractor to delay prosecution of the Work if Contractor has been authorized in writing by Public Works Project Engineer to proceed.

## **19. EXTRAS**

- A. Without invalidating Contract, Department may order extra work or make changes by altering, adding to or deducting from the Work, contract sum being adjusted in accordance with Article 18 herein.

## **20. TIME FOR COMPLETION**

- A. Contractor agrees that the Work shall be prosecuted regularly and diligently and complete the Work as stated in Construction Documents.

## **21. CORRECTION OF WORK**

- A. All work, all materials whether incorporated in the Work or not, and all processes of manufacture shall at all times and places be subject to inspection of Architect / Engineer and Public Works Project Engineer who shall be judge of quality and suitability of the Work, materials, and processes of manufacture for purposes for which they are used. Should they fail to meet Architect / Engineer's and Public Works Project Engineer's approval they shall be reconstructed, made good, replaced or corrected, by Contractor at Contractor's expense. Immediately remove all rejected material from site.
- B. If Contractor defaults or neglects to carry out the Work in accordance with Construction Documents or fails to perform any provision of Contract, Department may, after ten (10) days' written notice to Contractor and without prejudice to any other remedy County may have, make good such deficiencies. In such case, an appropriate Change Order shall be issued deducting from Contractor's payments then or thereafter, cost of correcting such deficiencies, including cost of Architect / Engineer's additional services made necessary by such default, neglect or failure.



## **22. SUBSURFACE CONDITIONS FOUND DIFFERENT**

- A. If Contractor encounters subsurface or latent conditions at site materially differing from those shown on Drawings or indicated in Specifications, Contractor shall immediately give notice to Architect / Engineer and Public Works Project Engineer of such conditions before they are disturbed. Architect / Engineer will thereupon promptly investigate conditions, and if Architect / Engineer finds that they materially differ from those shown on Drawings or indicated in Specifications, Architect / Engineer will at once make such changes as necessary, any increase or decrease of cost resulting from such changes to be adjusted in manner provided in above Article 18 entitled "Changes in the Work".

## **23. RIGHT OF THE DEPARTMENT TO TERMINATE CONTRACT**

- A. In event that any provisions of this Contract are violated by Contractor or by any subcontractors, County may serve written notice upon Contractor and Surety of its intention to terminate Contract, such notice to contain reasons for such intention to terminate Contract, and unless within ten (10) days after serving of such notice upon Contractor, such violation or delay shall cease and satisfactory arrangement or correction be made, Contract shall, upon expiration of said ten (10) days, cease and terminate.
- B. In event of any such termination, County shall immediately serve notice thereof upon Surety and Contractor, and Surety shall have right to take over and perform Contract subject to County's approval; provided, however, that if Surety does not commence performance thereof within ten (10) days from date of mailing to such Surety of notice of termination, County may take over the Work and prosecute same to completion by contract, or by force account, at expense of Contractor; Contractor and Surety shall be liable to County for any excess cost occasioned County thereby, and in such event County may take possession of and utilize in completing the Work, such materials and equipment as may be on the Work site and therefore necessary.

## **24. CONSTRUCTION SCHEDULE AND PERIODIC ESTIMATES**

- A. Contractor shall be responsible for Construction Schedule and coordination. Immediately after execution and delivery of Contract and before making first payment, Contractor shall notify all subcontractors to furnish all required information to develop a Construction Schedule. Contractor and all subcontractors associated with the Work shall furnish following information from each Division of Specifications:
  - 1. A list of construction activities;
  - 2. Start, finish and time required for completion of each activity;
  - 3. Sequential relationships between activities;
  - 4. Identify all long lead-time items, key events, meetings or activities such as required submittals, fabrication and delivery, procurement of materials, installation and testing;
  - 5. Weekly definition of extent of work and areas of activity for each trade or Subcontract;
  - and
  - 6. Other information as determined by Public Works Project Engineer.
- B. In addition to above requested items, Contractor shall request delivery dates for all County-furnished equipment, materials or labor. This shall include any work handled by Department under separate contracts such as asbestos abatement, air and water balancing, etc. Indicate on Construction Schedule these associated delivery and installation dates.

- C. Progress Reporting:
1. Contractor shall update and publish Construction Schedule on a monthly basis. Revisions to Schedule shall be by Contractor and made in same detail as original Schedule and accompanied by an explanation of reasons for revision; and shall be subject to approval by Department.
  2. Failure of Contractor to keep Schedule in updated format shall result in County hiring a firm specializing in construction schedule development and deducting those costs associated with updating process from payments due Contractor.
  3. Contractor shall submit show actual percentage of each activity completed, estimated future progress, and anticipated completion time.
- D. Responsibility for timely completion requires:
1. Contractor and subcontractors understand that performance of each is interdependent upon performance of others.
  2. Whenever it becomes apparent from current schedule, that phasing or progress completion dates will not be met, Contractor must take some or all following actions at no additional cost to County:
    - a) Increase construction manpower in such quantities and crafts as will eliminate backlog of work.
    - b) Increase number of working hours per shift, shifts per working day, working days per week, amount of construction equipment, or any combination of foregoing to eliminate backlog of work.
    - c) Reschedule work (yet remain in conformance with Drawings and Specifications).
  3. Prior to proceeding with any of above actions, Contractor shall notify Public Works Project Engineer.
- E. Maintain current Construction Schedule at all times. Revise Construction Schedule in same detail as original and accompany with explanation of reasons for revision. Schedule shall be subject to approval by Architect / Engineer and Public Works Project Engineer.

## **25. PAYMENTS TO CONTRACTOR**

- A. Contractor shall provide:
1. Detailed estimate giving a complete breakdown of contract price by Specification Division; and
  2. Periodic itemized estimates of work done for purpose of making partial payments thereon. Submit these estimates for approval first to Architect / Engineer, then to Public Works Project Engineer. Costs employed in making up any of these schedules are for determining basis of partial payments and not considered as fixing a basis for additions to or deductions from Contract price.
- B. County will make partial payments to Contractor for value, proportionate to amount of Contract, of all labor and material incorporated in the Work during preceding calendar month upon receipt of Application and Certificate for Payment form from Architect / Engineer and approval of Department.
- C. Contractor shall submit for approval first to Architect / Engineer, and then to Public Works Project Engineer all Application and Certificate for Payment forms. If requested, Application and Certificate for Payment shall be supported by such additional evidence as may be required, showing Contractor's right to payment claimed.

- D. Application and Certificate for Payment for preparatory work and materials delivered and suitably stored at site to be incorporated into the Work at some future period, will be given due consideration. Requesting payment for materials stored off site, may be rejected, however, if deemed essential for reasons of job progress, protection, or other sufficient cause, requests will be considered, conditional upon submission by Contractor of bills of sale, photographs and such other procedures as will adequately protect County's interest such as storage in a bonded warehouse with adequate coverage. If there is any error in a payment, Contractor is obligated to notify Department immediately, but no longer than ten (10) days from receipt of payment.
- E. Payments by County will be due within forty-five (45) days after receipt by Department of Application and Certificate for Payment.
- F. County will retain five percent (5%) of each Application and Certificate for Payment until final completion and acceptance of all the Work covered by Contract. However, anytime after fifty percent (50%) of the Work has been furnished and installed at site, County will make remaining payments in full if Architect / Engineer and Public Works Project Engineer find that progress of the Work corresponds with Construction Schedule. If Architect / Engineer and Public Works Project Engineer find that progress of the Work does not correspond with Construction Schedule, County may retain up to ten percent (10%) of each Application and Certificate for Payment for the Work completed.
- G. All material and work covered by partial payments made shall become sole property of County, but this provision shall not be construed as relieving Contractor from sole responsibility for care and protection of materials and work upon which payments have been made, or restoration of any damaged work, or as a waiver of right of County to require fulfillment of all of terms of Contract.
- H. County will make final payment within sixty (60) days after final completion of the Work, and will constitute acceptance thereof.
- I. County may make payment in full, including retained percentages and less authorized deductions, upon completion and acceptance of each Division where price is stated separately in Contract.
- J. Every contractor engaged in performance of any contract for Department of Public Works, Highway & Transportation shall submit to this Department, as requested and with final application for payment for work under said contract, affidavit(s) as required to prove that all debts and claims against this Work are paid in full or otherwise satisfied, and give final evidence of release of all liens against the Work and County. If Wisconsin Prevailing Wage Rate Determination is required for this Work, use "Prime Contractor Affidavit of Compliance With Prevailing Wage Rate Determination" and "Agent or Subcontractor Affidavit of Compliance With Prevailing Wage Rate Determination" (if applicable). If Wisconsin Prevailing Wage Rate Determination is not required for this Work, use "Dane County, Wisconsin Contractor Wage Affidavit". Forms of such affidavits are included in Supplementary Conditions.

## **26. WITHHOLDING OF PAYMENTS**

- A. County, after having served written notice on said Contractor, may either pay directly any unpaid bills of which Department has written notice, or withhold from Contractor's unpaid compensation a sum of money deemed reasonably sufficient to pay any and all such lawful claims until satisfactory evidence is furnished that all liabilities have been fully discharged; whereupon, payment to Contractor shall be resumed in accordance with terms of this Contract, but in no event shall these provisions be construed to impose any obligations upon County to either Contractor or Contractor's Surety.
- B. In paying any unpaid bills of Contractor, County shall be deemed agent of Contractor, and any payment so made by County, shall be considered as a payment made under Contract by County to Contractor and County shall not be liable to Contractor for any such payment made in good faith.
- C. Contractor shall indemnify, hold harmless and defend Dane County, its boards, commissions, agencies, officers, employees and representatives from all claims growing out of lawful demands of subcontractors, laborers, workmen, mechanics, material men, and furnishers of machinery and parts thereof, equipment, power tools, and all supplies, including commissary, incurred in performance of this Contract.
- D. At Department's request, Contractor shall furnish satisfactory evidence that all obligations of nature designated above have been paid, discharged or waived.

## **27. ACCEPTANCE OF FINAL PAYMENT AS RELEASE**

- A. Making of final payment shall constitute a waiver of all claims by County except those arising from:
  - 1. Unsettled lien;
  - 2. Faulty or defective work appearing after substantial completion;
  - 3. Failure of the Work to comply with requirements of Construction Documents; or
  - 4. Terms of any special guarantees required by Construction Documents.
- B. Acceptance of final payment shall constitute a waiver of all claims by Contractor.

## **28. PAYMENTS BY CONTRACTOR**

- A. Contractor shall pay following not later than fifth (5<sup>th</sup>) day following each payment received from County:
  - 1. All transportation and utility services rendered;
  - 2. All materials, tools, and other expendable equipment that have been delivered at site of the Work to extent of ninety percent (90%) of cost thereof, and balance of cost thereof when said balance is paid to Contractor; and
  - 3. Each subcontractor, respective amount allowed Contractor because of work performed by subcontractor to extent of subcontractor's interest therein.

## **29. CONTRACT SECURITY**

- A. Contractor shall furnish a Performance and Payment Bonds in an amount at least equal to one hundred percent (100%) of Contract price as security for faithful performance of this Contract and payment of all persons performing labor on project under this Contract and furnishing materials in connection with this Contract.

- B. Sample Performance and Payment Bonds that Contractor will be required to execute is bound into these Construction Documents. Before construction Contract is consummated, completed Performance and Payment Bonds must be approved by Department.

### **30. ASSIGNMENTS**

- A. Contractor shall not assign whole or any part of this Contract or any moneys due or to become due hereunder without written consent of Department. In case Contractor assigns all or any part of any moneys due or to become due under this Contract, instrument of assignment shall contain a clause substantially to effect that it is agreed that right of assignee in and to any moneys due or to become due to Contractor shall be subject to prior claims of all persons, firms and corporations for services rendered or materials supplied for performance of the Work called for in this Contract.

### **31. MUTUAL RESPONSIBILITY OF CONTRACTORS**

- A. If, through acts of neglect on part of Contractor or any subcontractor shall suffer loss or damage on the Work, Contractor agrees to settle with such subcontractor by agreement or arbitration if such other subcontractor will so settle. If such subcontractor shall assert any claim against County on account of any damage alleged to have been sustained, Department shall notify Contractor, who shall indemnify, hold harmless and defend Dane County, its boards, commissions, agencies, officers, employees and representatives against any such claim.

### **32. SEPARATE CONTRACTS**

- A. Department may award other contracts for the Work and all Contractors shall fully cooperate with each other and carefully adjust their work to that provided under other contracts as may be directed by Department. No Contractor shall commit or permit any act that will interfere with performance of the Work by any other Contractor.
- B. Contractor shall coordinate the Work with those of other Contractors. Cooperation will be required in arrangement for storage of materials and in detailed execution of the Work. Contractor, including subcontractors, shall keep informed of progress and detail work of others and shall notify Architect / Engineer or Department immediately of lack of progress or defective workmanship on part of others. Failure of Contractor to keep informed of the Work progressing on site and failure to give notice of lack of progress or defective workmanship by others shall be construed as acceptance by Contractor of status of the Work as being satisfactory for proper coordination with Contractor's own work.

### **33. SUBCONTRACTS**

- A. Contractor may use services of specialty subcontractors on those parts of the Work that, under normal contracting practices, are performed by specialty subcontractors.
- B. Contractor shall not award any work to any subcontractor without prior approval of Department. Qualifications of subcontractors shall be same as qualifications of Contractor. Request for subcontractor approval shall be submitted to Department fifteen (15) days before start of subcontractor's work. If subcontractors are changed or added, Contractor shall notify Department in writing.

- C. Contractor shall be as fully responsible to County for acts and omissions of subcontractors, and of persons either directly or indirectly employed by them, as Contractor is for acts and omissions of persons directly employed by Contractor.
- D. Contractor shall cause appropriate provisions to be inserted in all subcontracts relative to the Work to bind subcontractors to Contractor by terms of General Conditions of Contract and other Construction Documents insofar as applicable to work of subcontractors and to give Contractor same power as regards terminating any subcontract that Department may exercise over Contractor under any provision of Construction Documents.
- E. Nothing contained in this Contract shall create any contractual relation between any subcontractor and County.
- F. Contractor shall insert in all subcontracts, Articles 26, 33, 43 and 45, respectively entitled: "Withholding of Payments", "Subcontracts", "Affirmative Action Provision and Minority / Women / Disadvantaged Business Enterprises", and "Minimum Wages", and shall further require all subcontractors to incorporate physically these same Articles in all subcontracts.

#### **34. PUBLIC WORKS PROJECT ENGINEER'S AUTHORITY**

- A. Public Works Project Engineer shall:
  - 1. Administer and ensure compliance with Construction Documents;
  - 2. Provide responsible on-site observations of construction and have authority to request work and to stop work whenever necessary to insure proper enforcement of Construction Documents;
  - 3. Convene and chair project meetings and foreman's coordination meetings when necessary to coordinate resolution of conflicts between Contractors, Architects, Engineers, Consultants, and Department; and
  - 4. Check and inspect material, equipment and installation procedures of all trades for proper workmanship and for compliance with Drawings, Specifications and Shop Drawings, permit no material on project site that is not satisfactory and reject work not in compliance with Construction Documents.

#### **35. ARCHITECT / ENGINEER'S AUTHORITY**

- A. Architect / Engineer is retained by, and is responsible to Department acting for County.
- B. Architect / Engineer shall determine amount, quality, acceptability, and fitness of several kinds of work and materials that are provided under this Contract and shall decide all questions that may arise in relation to said work and construction thereof.
- C. Architect / Engineer shall decide meaning and intent of any portion of Specifications and of any Drawings where they may be found obscure or be in dispute.
- D. Architect / Engineer shall provide responsible observation of construction. Architect / Engineer has authority to stop the Work whenever such stoppage may be necessary to insure proper execution of Construction Documents.
- E. Architect / Engineer shall be interpreter of conditions of Construction Documents and judge of its performance.

- F. Within a reasonable time, Architect / Engineer shall make decisions on all matters relating to progress of the Work or interpretation of Construction Documents.
- G. Architect / Engineer's decisions are subject to review by Public Works Project Engineer.

### **36. STATED ALLOWANCES**

- A. Stated allowances enumerated in Instructions to Bidders shall cover net cost of materials or equipment, and all applicable taxes. Contractor's cost of delivery and unloading at site, handling costs on site, labor, installation costs, overhead, profit and any other incidental costs shall be included in Contractor's bid, but not as a part of cash allowance.
- B. Department will solicit at least two (2) bids on materials or equipment for which an allowance is stated and select on basis of lowest qualified responsible bid. Contractor will then be instructed to purchase "Allowed Materials". If actual price for purchasing "Allowed Materials", including taxes, is more or less than "Cash Allowance", Contract price shall be adjusted accordingly. Adjustment in Contract price shall not contain any cost items excluded from cash allowance.

### **37. ESTIMATES OF QUANTITIES**

- A. Whenever estimated quantities of work to be done and materials to be furnished under this Contract are shown in any of Construction Documents, they are given for use in comparing bids and right is especially reserved to increase or diminish them as they may be deemed reasonably necessary or desirable by Department to complete the Work included in this Contract, and cost for such increase or diminution shall be adjusted in manner provided for in General Conditions of Contract Article 18 entitled "Changes in the Work".

### **38. LANDS AND RIGHTS-OF-WAY**

- A. Prior to start of construction, County shall furnish all land and rights-of-way necessary for carrying out and completion of the Work to be performed under this Contract.

### **39. GENERAL GUARANTEE**

- A. Neither final certificate of payment nor any provision in Construction Documents nor partial or entire occupancy of premises by County shall constitute an acceptance of work not done in accordance with Construction Documents or relieve Contractor of liability in respect to any expressed warranties or responsibility for faulty materials or workmanship.
  - 1. In no event shall making of any payment required by Contract constitute or be construed as a waiver by County of any breach of covenants of Contract or a waiver of any default of Contractor and making of any such payment by County while any such default or breach shall exist shall in no way impair or prejudice right of County with respect to recovery of damages or other remedy as a result of such breach or default.
- B. Contractor shall remedy and make good all defective workmanship and materials and pay for any damage to other work resulting there from, which appear within a period of one (1) year from date of substantial completion, providing such defects are not clearly due to abuse or misuse by County. Department will give notice of observed defects with reasonable promptness.

- C. Guarantee on work executed after certified date of substantial completion will begin on date when such work is inspected and approved by Architect / Engineer and Public Works Project Engineer.
- D. Where guarantees or warranties are required in sections of Specifications for periods in excess of one (1) year, such longer terms shall apply; however, Contractor's Performance and Payment Bonds shall not apply to any guarantee or warranty period in excess of one (1) year.

#### **40. CONFLICTING CONDITIONS**

- A. Any provision in any of Construction Documents which may be in conflict or inconsistent with any Articles in these General Conditions of Contract or Supplementary Conditions shall be void to extent of such conflict or inconsistency.
- B. In case of ambiguity or conflict between Drawings and Specifications, Specifications shall govern.
- C. Printed dimensions shall be followed in preference to measurements by scale. Large-scale drawings take precedence over small-scale drawings. Dimensions on Drawings and details are subject to field measurements of adjacent work.

#### **41. NOTICE AND SERVICE THEREOF**

- A. Any notice to Contractor from Department relative to any part of this Contract shall be in writing and considered delivered and service thereof completed, when said notice is posted, by certified or registered mail, to Contractor at Contractor's last given address, or delivered in person to said Contractor, or Contractor's authorized representative on the Work.

#### **42. PROTECTION OF LIVES AND HEALTH**

- A. In order to protect lives and health of Contractor's employees under Contract, Contractor shall comply with all pertinent provisions of Wisconsin Administrative Code, Rules of Department of Commerce, relating to Safety and Health.
- B. Contractor alone shall be responsible for safety, efficiency and adequacy of Contractor's tools, equipment and methods, and for any damage that may result from their failure or their improper construction, maintenance or operation.

#### **43. AFFIRMATIVE ACTION PROVISION AND MINORITY / WOMEN / DISADVANTAGED BUSINESS ENTERPRISES**

- A. Affirmative Action Provisions.
  - 1. During term of their Contract, Contractor agrees not to discriminate on basis of race, religion, color, sex, handicap, age, sexual preference, marital status, physical appearance, or national origin against any person, whether a recipient of services (actual or potential), an employee, or an applicant for employment. Such equal opportunity shall include but not be limited to following: employment, upgrading, demotion, transfer, recruitment, advertising, layoff, termination, training, rates of pay, and any other form of compensation or level of service(s). Contractor agrees to post in conspicuous places, these affirmative



action standards so as to be visible to all employees, service recipients and applicants for this paragraph. Listing of prohibited bases for discrimination shall no be construed to amend in any fashion state or federal law setting forth additional bases and exceptions shall be permitted only to extent allowable in state or federal law.

2. Contractor is subject to this Article only if Contractor has ten (10) or more employees and receives \$10,000.00 or more in annual aggregate contracts with County. Contractor shall file and Affirmative Action Plan with Dane County Contract Compliance Officer in accord with Chapter 19 of Dane County Code of Ordinances. Such plan must be filed within fifteen (15) days of effective date of this Contract and failure to do so by said date shall constitute ground for immediate termination of Contract by County. Contractor shall also, during term of this Contract, provide copies of all announcements of employment opportunities to County's Contract Compliance Office, and shall report annually number of persons, by race, sex and handicap status, who apply for employment and, similarly classified, number hired and number rejected.
3. Contact Dane County Contract Compliance Officer at Dane County Contract Compliance Office, 210 Martin Luther King, Jr. Blvd., Room 421, Madison, WI 53703, 608/266-4114.
4. In all solicitations for employment placed on Contractor's behalf during term of this Contract, Contractor shall include a statement to effect Contractor is an "Equal Opportunity Employer". Contractor agrees to furnish all information and reports required by County's Contract Compliance Officer as same relate to affirmative action and nondiscrimination, which may include any books, records, or accounts deemed appropriate to determine compliance with Chapter 19, Dane County Code of Ordinances, and provision of this Contract.

B. Minority / Women / Disadvantaged / Emerging Small Business Enterprises.

1. Chapter 19.508 of Dane County Code of Ordinances is official policy of Dane County regarding utilization of, to fullest extent of, Minority Business Enterprises (MBEs), Women Business Enterprises (WBEs) Disadvantage Business Enterprises (DBEs) and Emerging Small Business Enterprises (ESBEs).
2. Contractor may utilize MBEs / WBEs / DBEs / ESBEs as subcontractors or suppliers. A list of subcontractors will be required of low bidder as stated in this Contract. List shall indicate which are MBEs / WBEs / DBEs / ESBEs and percentage of subcontract awarded, shown as a percentage of total dollar amount of bid.

#### **44. COMPLIANCE WITH FAIR LABOR STANDARDS**

- A. During term of this Contract, Contractor shall report to County Contract Compliance Officer, within ten (10) days, any allegations to, or findings by National Labor Relations Board (NLRB) or Wisconsin Employment Relations Commission (WERC) that Contractor has violated statute or regulation regarding labor standards or relations. If investigation by Contract Compliance Officer results in final determination that matter adversely affects Contractor's responsibilities under this Contract, and which recommends termination, suspension or cancellation of this Contract, County may take such action.
- B. Contractor may appeal any adverse finding by Contract Compliance Officer as set forth in Dane County Ordinance 25.015(11)(c) through (e).
- C. Contractor shall post this statement in prominent place visible to employees: "As condition of receiving and maintaining contract with Dane County, this employer shall comply with federal, state and all other applicable laws prohibiting retaliation or union organizing."

#### **44. USE AND OCCUPANCY PRIOR TO ACCEPTANCE**

- A. Contractor agrees to use and occupancy of a portion or unit of the Work before formal acceptance by Department, provided Department:
  - 1. Secures written consent of Contractor; except when in opinion of Public Works Project Engineer, Contractor is chargeable with unwarranted delay in final cleanup of punch list items or other Contract requirements.
  - 2. Secures endorsement from insurance carrier and consent of Surety permitting occupancy of building or use of the Work during remaining period of construction, or, secures consent of Surety.
  - 3. Assumes all costs and maintenance of heat, electricity and water.
  - 4. Accepts all work completed within that portion or unit of the Work to be occupied, at time of occupancy.

#### **45. MINIMUM WAGES**

- A. Contractor shall post, at appropriate conspicuous point on site of project, a schedule showing all determined minimum wage rates for various classes of laborers and mechanics to be engaged in the Work under this Contract and all deductions, if any, required by law to be made from unpaid wages actually earned by laborers and mechanics so engaged.
- B. Supplementary Conditions section in Construction Documents lists wage determinations required by State Law.
- C. If, after award of Contract, it becomes necessary to employ any person in a trade or occupation not classified in wage determinations, such person shall be paid at not less than such rate as shall be determined by Wisconsin Department of Workforce Development. Such approved minimum rate shall be retroactive to time of initial employment of such person in such trade or occupation. Contractor shall notify Department of Contractor's intention to employ persons in trades or occupations not so classified in sufficient time for Department to obtain approved rates for such trades or occupations.
- D. Specified wage rates are minimum rates only, and Department will not consider any claims for additional compensation made by Contractor because of payment by Contractor of any wage rate in excess of applicable rate contained in this Contract. Contractor shall adjust any disputes in regard to payment of wages in excess of those specified in this Contract.
- E. Submit required affidavit(s) to Department of Public Works, Highway & Transportation, as requested and with final application for payment for work under said contract. Affidavit(s) shall clearly indicate name, trade or occupation, and paid wages of every laborer, workman or mechanic employed by Contractor and all subcontractors during billing period including accurate record of number of hours worked by each employee and actual wages paid as stipulated in Wisconsin Statue 66.0903. If Wisconsin Prevailing Wage Rate Determination is required for this Work, use "Prime Contractor Affidavit of Compliance With Prevailing Wage Rate Determination" and "Agent or Subcontractor Affidavit of Compliance With Prevailing Wage Rate Determination" (if applicable). If Wisconsin Prevailing Wage Rate Determination is not required for this Work, use "Dane County, Wisconsin Contractor Wage Affidavit". Forms of such affidavits are included in Supplementary Conditions.

## **46. CLAIMS**

- A. No claim may be made until Department's Associate Public Works Director has reviewed Architect / Engineer's decision as provided for in Article 35 of General Conditions of Contract. If any claim remains unresolved after such review by Department's Associate Public Works Director, claim may be filed under Wisconsin Statute 893.80. Work shall progress during period of any dispute or claim. Unless specifically agreed between parties, venue will be in Dane County, Wisconsin.

## **47. ANTITRUST AGREEMENT**

- A. Contractor and County recognize that in actual economic practice, overcharges resulting from antitrust violations are in fact usually borne by County. Therefore, Contractor hereby assigns to County any and all claims for such overcharges as to goods and materials purchased in connection with this Contract, except as to overcharges which result from antitrust violations commencing after price is established under this Contract and any change order thereto.

## **48. INSURANCE**

- A. Contractor Carried Insurance:
  - 1. Contractor shall not commence work under this Contract until Contractor has obtained all insurance required under this Article and has provided evidence of such insurance to Risk Manager, 425 City-County Building, 210 Martin Luther King Jr. Blvd., Madison, WI 53703. Contractor shall not allow any subcontractor to commence work until insurance required of subcontractor has been so obtained and approved. Company providing insurance must be licensed to do business in Wisconsin.
  - 2. Worker's Compensation Insurance:
    - a) Contractor shall procure and shall maintain during life of this Contract, Worker's Compensation Insurance as required by statute for all of Contractor's employees engaged in work at site of project under this Contract and, in case of any such work sublet, Contractor shall require subcontractor similarly to provide Worker's Compensation Insurance for all of latter's employees to be engaged in such work unless such employees are covered by protection afforded by Contractor's Worker's Compensation Insurance.
    - b) If any claim of employees engaged in hazardous work on project under this Contract is not protected under Worker's Compensation Statute, Contractor shall provide and shall cause each subcontractor to provide adequate Employer's Liability Insurance for protection of such of Contractor's employees as are not otherwise protected.
  - 3. Contractor's Public Liability and Property Damage Insurance:
    - a) Contractor shall procure and maintain during life of this Contract, Contractor's Public Liability Insurance and Contractor's Property Damage Insurance in an amount not less than \$1,000,000 bodily injury, including accidental death, to any one person, and subject to same limit for each person, in an amount not less than \$1,000,000 on account of one accident, and Contractor's Property Damage Insurance in an amount not less than \$1,000,000 or a combined single limit of at least \$1,000,000 with excess coverage over and above general liability in an amount not less than \$5,000,000. Contractor shall add "Dane County" as an additional insured for each project.
    - b) Contractor's Public Liability and Property Damage Insurance shall include Products, Completed Operation, and Contractual Liability under Insurance Contract.  
"Contractor shall in all instances save, defend, indemnify and hold harmless County

and Architect / Engineer against all claims, demands, liabilities, damages or any other costs which may accrue in prosecution of the Work and that Contractor will save, defend, indemnify and hold harmless County and Architect / Engineer from all damages caused by or as a result of Contractor's operations" and each shall be listed as additional insured on Contractor's and sub-contractors' insurance policies.

- c) Obligations of Contractor under Article 48.A.2)b) shall not extend to liability of Architect / Engineer, agents or employees thereof, arising out of:
    - 1) Preparation or approval of maps, drawings, opinions, reports, surveys, change orders, designs or specifications; or
    - 2) giving of or failure to give directions or instructions by Architect / Engineer, agents or employees thereof provided such giving or failure to give is primary cause of injury or damage.
  - d) Contractor shall procure and shall maintain during life of this Contract, Comprehensive Automobile Liability Insurance covering owned, non-owned and hired automobiles for limits of not less than \$1,000,000 each accident single limit, bodily injury and property damage combined with excess coverage over and above general liability in an amount not less than \$5,000,000.
  - e) Contractor shall either:
    - 1) Require each subcontractor to procure and to maintain during life of subcontract, subcontractor's Public Liability Property Damage Insurance, and Comprehensive Automobile Liability Insurance of type and in same amount specified in preceding paragraphs; or
    - 2) Insure activities of subcontractors in Contractor's own policy.
4. Scope of Insurance and Special Hazards: Insurance required under Article 48.A.2 hereof shall provide adequate protection for Contractor and subcontractors, respectively, against damage claims which may arise from operations under this Contract, whether such operation be by insured or by anyone directly or indirectly employed by insured and also against any of special hazards which may be encountered in performance of this Contract as enumerated in Supplementary Conditions.
5. Proof of Carriage of Insurance: Contractor shall furnish Risk Manager with certificates showing type, amount, class of operations covered, effective dates, dates of expiration of policies and "Dane County" listed as an additional insured. Such certificates shall also contain (substantially) following statement: "Insurance covered by this certificate will not be canceled or materially altered, except after ten (10) days written notice has been received by Risk Manager."

**B. Builder's Risk:**

- 1. Contractor shall provide Builder's Risk policy when project is new construction or roofing project. Policy shall name Dane County as additional insured.

**C. Indemnification / Hold Harmless:**

- 1. Contractor shall indemnify, hold harmless and defend Dane County, its boards, commissions, agencies, officers, employees and representatives from and against all claims, damages, losses and expenses including attorneys' fees arising out of or resulting from performance of the Work, provided that any such claim, damage, loss or expense is attributable to bodily injury, sickness, disease or death, or to injury to or destruction of tangible property (other than the Work itself) including loss of use resulting therefrom, and is caused in whole or in part by any act or omission of Contractor, any subcontractor, anyone directly or indirectly employed by any of them or anyone for whose acts any of them may be liable, regardless of whether or not it is caused in part by a part indemnified hereunder.

2. In any and all claims against Dane County, its boards, commissions, agencies, officers, employees and representatives or by any employee of Contractor, any subcontractor, anyone directly or indirectly employed by any of them or anyone for whose acts any of them may be liable, indemnification obligation under this Contract shall not be limited in any way by any limitation on amount or type of damages, compensation or benefits payable by or for Contractor or any subcontractor under worker's compensation acts, disability benefits or other employee benefit acts.
3. Obligations of Contractor under this Contract shall not extend to liability of Architect / Engineer, its agents or employees arising out of:
  - a) Preparation or approval of maps, drawings, opinion, reports, surveys, change orders, designs or specifications; or
  - b) Giving of or failure to give directions or instruction by Architect / Engineer, its agents or employees provided such giving or failure to give is primary cause of injury or damage.
4. Dane County shall not be liable to Contractor for damages or delays resulting from work by third parties or by injunctions or other restraining orders obtained by third parties.

#### **49. WISCONSIN LAW CONTROLLING**

- A. It is expressly understood and agreed to by parties hereto that in event of any disagreement or controversy between parties, Wisconsin law shall be controlling.

## SUPPLEMENTARY CONDITIONS

### 1. APPLICATION & CERTIFICATE FOR PAYMENT

- A. Every contractor engaged in performance of any contract for Department of Public Works, Highway & Transportation shall submit partial and final Application & Certificate for Payment for work under said contract. Form shall provide similar information as shown on AIA G702™ and G703™ forms (samples shown below). Forms shall be submitted to project Architect / Engineer, for approval.

**AIA Document G702™ – 1992**

**Application and Certificate for Payment**

TO OWNER:	PROJECT:	APPLICATION NO.:	Distribution to:
FROM CONTRACTOR:	VIA ARCHITECT:	PERIOD TO:	OWNER <input type="checkbox"/>
		CONTRACT FOR:	ARCHITECT <input type="checkbox"/>
		CONTRACT DATE:	CONTRACTOR <input type="checkbox"/>
		PROJECT NOS:	FIELD <input type="checkbox"/>
			OTHER <input type="checkbox"/>

**CONTRACTOR'S APPLICATION FOR PAYMENT**  
Application is made for payment, as shown below, in connection with the Contract Documents. AIA Document G703, is attached.

1. ORIGINAL CONTRACT SUM \$ \_\_\_\_\_

2. Net change by Change Orders \$ \_\_\_\_\_

3. CONTRACT SUM TO DATE (Line 1 + 2) \$ \_\_\_\_\_

4. TOTAL COMPLETED & STORED TO DATE (Column G on G703) \$ \_\_\_\_\_

5. RETAINAGE

a. % of Completed Work (Column D on G703) \$ \_\_\_\_\_

b. % of Stored Material (Column F on G703) \$ \_\_\_\_\_

Total Retainage (Sum of a + b) Total in Column I of G703) \$ \_\_\_\_\_

6. TOTAL EARNED LESS RETAINAGE (Line 4 less Line 5 Total) \$ \_\_\_\_\_

7. LESS PREVIOUS CERTIFICATES FOR PAYMENT (Line 6 from prior Certificate) \$ \_\_\_\_\_

8. CURRENT PAYMENT DUE \$ \_\_\_\_\_

9. BALANCE TO FINISH, INCLUDING RETAINAGE (Line 8 less Line 6) \$ \_\_\_\_\_

The undersigned Contractor certifies that to the best of the Contractor's knowledge, information and belief the Work covered by this Application for Payment has been completed in accordance with the Contract Documents, that all amounts have been paid by the Contractor for Work for which previous Certificates for Payment were issued and payments received from the Owner, and that correct payment should appear in your statement.

CONTRACTOR: \_\_\_\_\_ Date: \_\_\_\_\_

By: \_\_\_\_\_  
Name of Contractor  
Capacity of Contractor  
Subscribed and sworn to before me this \_\_\_\_\_ day of \_\_\_\_\_  
Notary Public  
My Commission expires: \_\_\_\_\_

**CHANGE ORDER SUMMARY**

CHANGE ORDER SUMMARY	ADDITIONS	DEDUCTIONS
Total changes approved in previous months by Owner	\$	\$
Total approved this Month	\$	\$
<b>TOTALS</b>	<b>\$</b>	<b>\$</b>
NET CHANGES by Change Order	\$	\$

**ARCHITECT'S CERTIFICATE FOR PAYMENT**  
In accordance with the Contract Documents, based on on-site observations and the data comprising this application, the Architect certifies to the Owner that to the best of the Architect's knowledge, information and belief the Work has progressed as indicated, the quality of the Work is in accordance with the Contract Documents, and the Contractor is entitled to payment of the AMOUNT CERTIFIED.

AMOUNT CERTIFIED \$ \_\_\_\_\_  
(Attach explanation if amount certified differs from the amount applied. Detail all figures on this Application and on the Continuation Sheet that are changed to conform with the amount certified.)

ARCHITECT: \_\_\_\_\_ Date: \_\_\_\_\_

This Certificate is not negotiable. The AMOUNT CERTIFIED is payable only to the Contractor named herein. Issuance, payment and acceptance of payment are without prejudice to any rights of the Owner or Contractor under this Contract.

AIA Document G702™ - 1992 Copyright © 1992, 1993, 1995, 1997, 1976, 1985 and 1992 by The American Institute of Architects. All rights reserved. WARNING: This AIA™ document is protected by U.S. Copyright Law and other national laws. Unauthorized reproduction or distribution of this AIA™ document, or any portion of it, may result in severe civil and criminal penalties, and will be prosecuted to the maximum extent possible under the law. Permission is granted to reproduce this (1) copy of this document when completed. To report copyright violations of AIA Contract Documents, e-mail The American Institute of Architects legal counsel, [copyright@aia.org](mailto:copyright@aia.org)

**Continuation Sheet**

AIA Document G703, APPLICATION AND CERTIFICATION FOR PAYMENT, containing Contractor's signed certification is attached.  
 In tabulations below, amounts are stated in the nearest dollar.  
 Use Column F on Contracts where variable invoice for line items may apply.

APPLICATION NO:  
 APPLICATION DATE:  
 PERIOD TO:  
 ARCHITECT'S PROJECT NO:

A ITEM NO.	B DESCRIPTION OF WORK	C SCHEDULED VALUE	D WORK COMPLETED		F MATERIALS PRESENTLY STORED (NET-GROSS) (DATE)	G TOTAL COMPLETED AND STORED TO DATE (Date+Y)	H % (D + E)	I BALANCE TO FINISH (C - I)	J RETAINAGE (IF VARIABLE) RATE
			E FROM PREVIOUS APPLICATION (D + E)	F THIS PERIOD					

**CAUTION:** You should sign an original AIA Contract Document, in which this text appears in RED. An original assures that changes will not be obscured.  
 AIA Document G703™ – 1992 Copyright © 1992, 1993, 1999, 1997, 1970, 1976, 1982 and 1992 by The American Institute of Architects. All rights reserved. (AIA/AR/AA). This AIA® Document is protected by U.S. Copyright Law and International Treaties. Unauthorized reproduction or distribution of this AIA® Document, or any portion of it, may result in severe civil and criminal penalties, and will be prosecuted to the maximum extent possible under the law. Purchasers are permitted to reproduce for internal use only copies of this document when compared to their approved editions of AIA Contract Documents, and that The American Institute of Architects agree to assist, copyright@aia.org.

**2. PREVAILING WAGE RATE DETERMINATION**

- A. These supplements shall modify, delete, and / or add to General Conditions of Contract. Where any article, paragraph, or subparagraph in General Conditions of Contract is supplemented by one of these paragraphs, provisions of such article, paragraph, or subparagraph shall remain in effect and supplementary provisions shall be considered as added thereto. Where any article, paragraph, or subparagraph in General Conditions of Contract is amended, voided, or superseded by any of these paragraphs, provisions of such article, paragraph, or subparagraph not so amended, voided, or superseded shall remain in effect.
  - 1. General Conditions of Contract Article 45, “Minimum Wages”, paragraph B. Following Prevailing Wage Rate Determination No. 200800745 is added to General Conditions of Contract.
  
- B. These State of Wisconsin forms, hereinafter set forth in this section, shall be filled out and submitted to Department of Public Works, Highway & Transportation:
  - 1. Prime Contractor Affidavit of Compliance With Prevailing Wage Rate Determination (ERD-5724)
  - 2. Agent or Subcontractor Affidavit of Compliance With Prevailing Wage Rate Determination (ERD-10584)
  - 3. Disclosure of Ownership (ERD-7777)
  - 4. Request To Employ Sub journey person (ERD-10880)

# Prime Contractor Affidavit of Compliance With Prevailing Wage Rate Determination

**NOTICE REQUIRED UNDER Section 15.04(1)(m), Wisconsin Statutes.** Authorization for this form is provided under Sections, 66.0903(9)(b) and 103.49(4r)(9b) Wisconsin Statutes. The use of this form is mandatory. The penalty for failing to complete this form is prescribed in Section 103.005(12), Wisconsin Statutes. Personally identifiable information may be used for secondary purposes.

This form must **ONLY** be filed with the **Awarding Agency** indicated below.

State Of            )  )SS  County Of            )	Project Name		
	Project Number	Determination Number	
	Date Determination Issued	Date of Contract	
	Awarding Agency		
	Date Work Completed		

After being duly sworn, the person whose name and signature appears below hereby states under penalty of perjury that

- **I am** the duly authorized officer of the corporation, partnership, sole proprietorship or business indicated below and have recently completed all of the work required under the terms and conditions of a contract with the above-named awarding agency and make this affidavit in accordance with the requirements set forth in Section 66.0903(9)(c) or 103.49(4r)(c), Wisconsin Statutes and Chapter DWD 290 of the Wisconsin Administrative Code in order to obtain FINAL PAYMENT from such awarding agency.
- **I have** fully complied with all of the wage and hour requirements applicable to this project, including all of the requirements set forth in the prevailing wage rate determination indicated above which was issued for such project by the Department of Workforce Development on the date indicated above.
- **I have** received the required affidavit of compliance from each of my agents and subcontractors that performed work on this project and have listed each of their names and addresses on page 2 of this affidavit.
- **I have** full and accurate records that clearly indicate the name and trade or occupation of every worker(s) that I employed on this project, including an accurate record of the hours worked and actual wages paid to such worker(s).
- **I will** retain the records and affidavit(s) described above and make them available for inspection for a period of at least three (3) years from the completion date indicated above at the address indicated below and shall not remove such records or affidavit(s) without prior notification to the awarding agency indicated above.

Name of Corporation, Partnership, Sole Proprietorship or Business				
Street Address or P O Box	City	State	Zip Code	Telephone Number (    )    -
Print Name of Authorized Officer			Date Signed	
Signature of Authorized Officer				



**List of Agents and Subcontractors**

Name			Name		
Street Address			Street Address		
City	State	Zip Code	City	State	Zip Code
Telephone Number ( ) -			Telephone Number ( ) -		
Name			Name		
Street Address			Street Address		
City	State	Zip Code	City	State	Zip Code
Telephone Number ( ) -			Telephone Number ( ) -		
Name			Name		
Street Address			Street Address		
City	State	Zip Code	City	State	Zip Code
Telephone Number ( ) -			Telephone Number ( ) -		
Name			Name		
Street Address			Street Address		
City	State	Zip Code	City	State	Zip Code
Telephone Number ( ) -			Telephone Number ( ) -		
Name			Name		
Street Address			Street Address		
City	State	Zip Code	City	State	Zip Code
Telephone Number ( ) -			Telephone Number ( ) -		
Name			Name		
Street Address			Street Address		
City	State	Zip Code	City	State	Zip Code
Telephone Number ( ) -			Telephone Number ( ) -		

**If you have any questions call (608) 266-0028**

## Agent or Subcontractor Affidavit of Compliance With Prevailing Wage Rate Determination

**NOTICE REQUIRED UNDER Section 15.04(1)(m), Wisconsin Statutes.** Authorization for this form is provided under Sections, 66.0903(9)(b) and 103.49(4r)(9b) Wisconsin Statutes. The use of this form is mandatory. The penalty for failing to complete this form is prescribed in Section 103.005(12), Wisconsin Statutes. Personally identifiable information may be used for secondary purposes.

This form must **ONLY** be filed with the **Awarding Contractor** indicated below.

State Of )	Project Name		
	Project Number	Determination Number	
)SS  County Of )	Date Determination Issued	Date of Subcontract	
	Awarding Contractor		
	Date Work Completed		

After being duly sworn, the person whose name and signature appears below hereby states under penalty of perjury that

- **I am** the duly authorized officer of the corporation, partnership, sole proprietorship or business indicated below. We have recently completed all of the work required under the terms and conditions of a subcontract with the above-named awarding contractor. We make this affidavit in accordance with the requirements set forth in Section 66.0903(9)(b) or 103.49(4r)(b), Wisconsin Statutes and Chapter DWD 290 of the Wisconsin Administrative Code in order to obtain FINAL PAYMENT from such awarding contractor.
- **I have** fully complied with all of the wage and hour requirements applicable to this project, including all of the requirements set forth in the prevailing wage rate determination indicated above which was issued for such project by the Department of Workforce Development on the date indicated above.
- **I have** received the required affidavit of compliance from each of my agents and subcontractors that performed work on this project and have listed each of their names and addresses on page 2 of this affidavit.
- **I have** full and accurate records that clearly indicate the name and trade or occupation of every worker(s) that I employed on this project, including an accurate record of the hours worked and actual wages paid to such worker(s).
- **I will** retain the records and affidavit(s) described above and make them available for inspection for a period of at least three (3) years from the completion date indicated above at the address indicated below and shall not remove such records or affidavit(s) without prior notification to the awarding contractor.

Name of Corporation, Partnership, Sole Proprietorship or Business				
Street Address	City	State	Zip Code	Telephone Number ( ) -
Print Name of Authorized Officer			Date Signed	
Signature of Authorized Officer				

**List of Agents and Subcontractors**

Name			Name		
Street Address			Street Address		
City	State	Zip Code	City	State	Zip Code
Telephone Number ( ) -			Telephone Number ( ) -		
Name			Name		
Street Address			Street Address		
City	State	Zip Code	City	State	Zip Code
Telephone Number ( ) -			Telephone Number ( ) -		
Name			Name		
Street Address			Street Address		
City	State	Zip Code	City	State	Zip Code
Telephone Number ( ) -			Telephone Number ( ) -		
Name			Name		
Street Address			Street Address		
City	State	Zip Code	City	State	Zip Code
Telephone Number ( ) -			Telephone Number ( ) -		
Name			Name		
Street Address			Street Address		
City	State	Zip Code	City	State	Zip Code
Telephone Number ( ) -			Telephone Number ( ) -		
Name			Name		
Street Address			Street Address		
City	State	Zip Code	City	State	Zip Code
Telephone Number ( ) -			Telephone Number ( ) -		

**If you have any questions call (608) 266-0028**

## Disclosure of Ownership

**Notice required under Section 15.04(1)(m), Wisconsin Statutes.** The statutory authority for the use of this form is prescribed in Sections 66.0903(12)(d) and 103.49(7)(d), Wisconsin Statutes. The use of this form is mandatory. The penalty for failing to complete this form is prescribed in Section 103.005(12), Wisconsin Statutes. Personal information you provide may be used for secondary purposes.

- (1) On the date a contractor submits a bid to or completes negotiations with a state agency or local governmental unit, on a project subject to Section 66.0903 or 103.49, Wisconsin Statutes, the contractor shall disclose to such state agency or local governmental unit the name of any "other construction business", which the contractor, or a shareholder, officer or partner of the contractor, owns or has owned within the preceding three (3) years.
- (2) The term "other construction business" means any business engaged in the erection, construction, remodeling, repairing, demolition, altering or painting and decorating of buildings, structures or facilities. It also means any business engaged in supplying mineral aggregate, or hauling excavated material or spoil as provided by Sections 66.0903(3), 103.49(2) and 103.50(2), Wisconsin Statutes.
- (3) This form must **ONLY** be filed, with the state agency or local governmental unit that will be awarding the contract, if **both (A) and (B) are met.**
  - (A) The contractor, or a shareholder, officer or partner of the contractor:
    - (1) Owns at least a 25% interest in the "other construction business", indicated below, on the date the contractor submits a bid or completes negotiations.
    - (2) Or has owned at least a 25% interest in the "other construction business" at any time within the preceding three (3) years.
  - (B) The Wisconsin Department of Workforce Development (DWD) has determined that the "other construction business" has failed to pay the prevailing wage rate or time and one-half the required hourly basic rate of pay, for hours worked in excess of the prevailing hours of labor, to any employee at any time within the preceding three (3) years.

### Other Construction Business

Name of Business

Street Address or P O Box

City

State

Zip Code

Name of Business

Street Address or P O Box

City

State

Zip Code

Name of Business

Street Address or P O Box

City

State

Zip Code

Name of Business

Street Address or P O Box

City

State

Zip Code

**I hereby state under penalty of perjury that the information, contained in this document, is true and accurate according to my knowledge and belief.**

Print the Name of Authorized Officer

Signature of Authorized Officer

Date Signed

Name of Corporation, Partnership or Sole Proprietorship

Street Address or P O Box

City

State

Zip Code

**If you have any questions call (608) 266-0028**

## Request To Employ Subjourneyperson

Personal information you provide may be used for secondary purposes. [See Section 15.04(1)(m), Wisconsin Statutes for details.] The use of this form is mandatory. The authority for the use of this form is prescribed in Section DWD 290.025, Wisconsin Administrative Code. The penalty for failing to complete this form is prescribed in Section 103.005(12), Wisconsin Statutes.

The employer indicated below requests that the Department of Workforce Development (DWD) determine the prevailing wage rate(s) and related qualifications to enable such employer to utilize a subjourneyperson(s) on the following public works project, in accordance with the provisions of Section DWD 290.025, Wisconsin Administrative Code.

<b>1. Name of Public Works Project</b>	
<b>County</b>	<b>City, Village or Township</b>
<b>Determination Number</b>	<b>Project Number</b>

<b>2. Name of Employee (Last, First and Initial)</b>	<b>P.O. Box or Street Address</b>	<b>City</b>	<b>State</b>	<b>Zip Code</b>

<b>3. Name of Employer (Print)</b>	<b>Name of Person Making Request</b>
<b>P O Box or Street Address</b>	<b>City</b>
<b>Telephone Number</b> ( ) -	<b>Title of Requestor</b>

**READ CAREFULLY:** I fully understand that this request is ONLY applicable to the project and employee(s) listed above and that such employee(s) will ONLY work under the direction of and directly assist a skilled trades employee by frequently using the tools of a skilled trades employee and will NOT regularly perform the duties of a general laborer, heavy equipment operator or truck driver. If the employee(s) indicated above regularly perform(s) the work of a different trade or occupation, he/she will be compensated for such work at the applicable journeypersons prevailing wage rate. I agree not to employ any employee as a subjourneyperson on this project until I receive written confirmation from the DWD. After such confirmation is received, I will compensate the employee(s) indicated above in strict accordance with the directions received from the DWD.

Signature of Requestor \_\_\_\_\_  
 Date Signed \_\_\_\_\_

MAIL COMPLETED REQUEST TO Equal Rights Division, Labor Standards Bureau, P.  
 O. Box 8928 Madison WI 53708.

You may call (608) 266-6860 if you need assistance in completing your request  
 ERD-10880-E (R. 10/2004)

Jim Doyle  
Governor  
Roberta Gassman  
Secretary  
Jennifer A. Ortiz  
Division Administrator



EQUAL RIGHTS DIVISION  
201 East Washington Avenue, Room A30  
P.O. Box 8928  
Madison, WI 53708  
Telephone: (608) 266-6860  
Fax: (608) 267-4592  
TTY: (608) 264-8752  
<http://www.dwd.state.wi.us/>

State of Wisconsin  
Department of Workforce Development

**DEPARTMENTAL ORDER**

TOM SRACIC, PROJ MGR  
DANE CO PUBLIC WORKS  
1919 ALLIANT ENERGY CTR WAY  
MADISON, WI 53713

RE: JOB CTR ROOF REPLACEMENT  
City of Madison, Dane Co, WI  
Determination No. 200800745      Project No. 108074

The application which you filed or was filed on your behalf, by the person copied below, for a prevailing wage rate determination applicable to the above-referenced project has been received.

A survey was conducted to determine the prevailing wage rate for the trade(s) or occupation(s) needed to complete the project. The findings of the survey are set forth in the enclosed determination.

If you believe that the wage rate for any trade or occupation does not accurately reflect the prevailing wage rate in the city, village or town in which the project is located, you have the right to request the department to conduct an administrative review regarding such wage rate.

Your request must be made, in writing, within 30 days from the date indicated below and at least 10 days before the date a construction contract(s) is to be awarded or negotiated. Your request must also include wage rate information on at least three (3) similar projects located in the city, village or town where the proposed project is located on which some work was performed by the contested trade(s) or occupation(s) during the current survey period and which was previously considered by the department in issuing the enclosed determination. See s. DWD 290.10 of the Wisconsin Administrative Code and either s. 66.0903 (3)(br) or s. 103.49 (3)(c), Stats. for a complete explanation of the administrative review process.

Now, therefore, it is hereby ORDERED that the prevailing wage rates set forth in the enclosed determination shall only be applicable to the above referenced project. This ORDER shall be deemed a FINAL ORDER of this department unless a timely request for an administrative review is filed with the department or a construction contract(s) is not awarded or negotiated before the determination's expiration date.

DATED

5/07/2008

Enclosures

FOR THE DEPARTMENT

A handwritten signature in black ink, appearing to read 'Julie Eckenwalder', written over a horizontal line.

Julie Eckenwalder, Chief  
Labor Standards Bureau  
Construction Wage Standards Section  
(608) 266-3148

## PREVAILING WAGE RATE DETERMINATION

Issued by the State of Wisconsin  
 Department of Workforce Development  
 Pursuant to s. 66.0903, Stats.  
 Issued On: 5/07/2008

**DETERMINATION NUMBER:** 200800745

**EXPIRATION DATE:** Prime Contracts MUST Be Awarded Or Negotiated On Or Before 12/31/2008. If NOT, You MUST Reapply.

**DESCRIPTION OF PROJECT:** JOB CTR ROOF REPLACEMENT  
 PROJECT NO: 108074

**LOCATION OF PROJECT:** City of Madison, Dane Co, WI

**CONTRACTING AGENCY:** DANE CO PUBLIC WORKS

**CLASSIFICATION:** Contractors are required to call the Department of Workforce Development if there are any questions regarding the proper trade or classification to be used for any worker on a public works project.

**OVERTIME:** Time and one-half must be paid for all hours worked over 10 hours per day and 40 hours per calendar week and for all hours worked on Saturday, Sunday and the following six (6) holidays: January 1; the last Monday in May; July 4; the 1st Monday in September; the 4th Thursday in November; December 25; the day before if January 1, July 4 or December 25 falls on a Saturday; the day following if January 1, July 4 or December 25 falls on a Sunday.

**FUTURE INCREASE:** If indicated for a specific trade or occupation, the full amount of such increase MUST be added to the "TOTAL" indicated for such trade or occupation on the date(s) such increase(s) becomes effective.

**PREMIUM PAY:** If indicated for a specific trade or occupation, the full amount of such pay MUST be added to the "HOURLY BASIC RATE OF PAY" indicated for such trade or occupation, whenever such pay is applicable.

**SUBJOURNEY:** Wage rates may be available for some of the classifications indicated below with the exception of laborers, truck drivers and heavy equipment operators. Any employer that desires to use any subjourney classification on this project MUST request the applicable wage rate from this department PRIOR to the date such classification is used on this project. Form ERD-10880 is available for this purpose.

### BUILDING OR HEAVY CONSTRUCTION

**Includes sheltered enclosures with walk-in access for the purpose of housing persons, employees, machinery, equipment or supplies and non-sheltered work such as canals, dams, dikes, reservoirs, storage tanks, etc. A sheltered enclosure need not be "habitable" in order to be considered a building. The installation of machinery and/or equipment, both above and below grade level, does not change a project's character as a building. On-site grading, utility work and landscaping are included within this definition. Residential buildings of four (4) stories or less, agricultural buildings, parking lots and driveways are NOT included within this definition.**

**Fringe Benefits Must Be Paid On All Hours Worked**

<u>TRADE OR OCCUPATION</u>	<u>HOURLY BASIC RATE OF PAY</u>	<u>HOURLY FRINGE BENEFITS</u>	<u>TOTAL</u>
	\$	\$	\$
Acoustic Ceiling Tile Installer	25.51	12.11	37.62
Boilermaker	29.44	16.37	45.81
Bricklayer, Blocklayer or Stonemason	29.46	13.41	42.87
Cabinet Installer	48.00	0.00	48.00
Carpenter	26.11	12.86	38.97
Carpet Layer or Soft Floor Coverer	25.51	12.11	37.62
Cement Finisher	28.43	12.94	41.37
Drywall Taper or Finisher	24.30	11.60	35.90

Future Increase(s): Add \$1.55/hr on 6/1/08; Add \$1.60/hr on 6/1/09

<b>Fringe Benefits Must Be Paid On <u>All</u> Hours Worked</b>			
<b><u>TRADE OR OCCUPATION</u></b>	<b><u>HOURLY BASIC RATE OF PAY</u></b>	<b><u>HOURLY FRINGE BENEFITS</u></b>	<b><u>TOTAL</u></b>
	<b>\$</b>	<b>\$</b>	<b>\$</b>
Electrician	30.00	16.05	46.05
Elevator Constructor	40.94	18.34	59.28
Fence Erector	21.50	3.00	24.50
Fire Sprinkler Fitter	35.69	13.35	49.04
Glazier	33.68	6.47	40.15
Heat or Frost Insulator	30.63	16.60	47.23
Insulator (Batt or Blown)	21.97	10.65	32.62
Ironworker	29.30	14.71	44.01
Lather	25.51	12.11	37.62
Line Constructor (Electrical)	31.99	13.94	45.93
Marble Finisher	24.60	13.00	37.60
Marble Mason	30.75	13.00	43.75
Metal Building Erector	19.23	1.61	20.84
Millwright	27.11	12.07	39.18
Overhead Door Installer	24.60	11.99	36.59
Painter	24.00	11.60	35.60
Future Increase(s): Add \$1.55 on 6/1/08; Add \$1.60 on 6/1/09			
Premium Pay: Add \$.25/hr. sandblasting; Add \$.40/hr. paperhanging; Add \$1.00/hr. spray/structural steel.			
Pavement Marking Operator	23.46	9.45	32.91
Piledriver	26.61	12.86	39.47
Pipeline Fuser or Welder (Gas or Utility)	27.11	12.19	39.30
Plasterer	25.28	12.95	38.23
Plumber	33.50	11.84	45.34
Future Increase(s): Add \$2.20/hr on 6/1/08			
Refrigeration Mechanic	33.11	14.84	47.95
Future Increase(s): Add \$2.60 6/2/2008; Add \$2.85 6/1/2009			
Roofer or Waterproofer	26.70	3.62	30.32
Sheet Metal Worker	30.96	16.34	47.30
Future Increase(s): Add \$2.50 6/1/2008			
Steamfitter	35.25	12.11	47.36
Future Increase(s): Add \$2.60 6/02/2008; Add \$2.85 6/01/2009			
Teledata Technician or Installer	20.69	10.23	30.92
Future Increase(s): Add \$.85 on 6/1/08; Add \$.90 on 6/1/09			
Temperature Control Installer	34.10	10.89	44.99
Terrazzo Finisher	26.62	10.63	37.25
Terrazzo Mechanic	26.62	10.63	37.25
Tile Finisher	14.00	1.35	15.35
Tile Setter	26.62	10.63	37.25
Tuckpointer, Caulker or Cleaner	20.98	6.02	27.00
Underwater Diver (Except on Great Lakes)	31.90	11.44	43.34
Well Driller or Pump Installer	22.52	7.14	29.66
Siding Installer	28.56	15.24	43.80
Heavy Equipment Operator - ELECTRICAL LINE CONSTRUCTION ONLY	24.06	15.52	39.58
Light Equipment Operator -ELECTRICAL LINE CONSTRUCTION ONLY	28.12	15.40	43.52



**Fringe Benefits Must Be Paid On All Hours Worked**

<u>TRADE OR OCCUPATION</u>	<u>HOURLY BASIC RATE OF PAY</u>	<u>HOURLY FRINGE BENEFITS</u>	<u>TOTAL</u>
	\$	\$	\$
Heavy Truck Driver - ELECTRICAL LINE CONSTRUCTION ONLY	16.00	8.00	24.00
Light Truck Driver - ELECTRICAL LINE CONSTRUCTION ONLY	20.58	10.71	31.29
Groundman - ELECTRICAL LINE CONSTRUCTION ONLY	17.41	9.80	27.21

**TRUCK DRIVERS**

Single Axle or Two Axle	24.55	16.08	40.63
Three or More Axle	16.40	11.17	27.57
Articulated, Euclid, Dumptor, Off Road Material Hauler	27.87	15.40	43.27
Pavement Marking Vehicle	20.85	11.10	31.95
Truck Mechanic	12.50	0.00	12.50

**LABORERS**

General Laborer	21.69	11.15	32.84
Premium Pay: Add \$1.00/hr for certified welder; Add \$.25/hr for mason tender			
Asbestos Abatement Worker	21.06	11.13	32.19
Landscaper	12.36	14.53	26.89
Gas or Utility Pipeline Laborer (Other Than Sewer and Water)	18.25	3.33	21.58
Fiber Optic Laborer (Outside, Other Than Concrete Encased)	40.00	1.81	41.81
Railroad Track Laborer	12.00	0.00	12.00

**HEAVY EQUIPMENT OPERATORS****SITE PREPARATION, UTILITY AND LANDSCAPING WORK ONLY**

Crane; Backhoe (Track Type); Tractor or Truck Mounted Hydraulic Backhoe; Gradall (Cruz-Aire Type); Mechanic or Welder; Bulldozer or Endloader; Grader or Motor Patrol; Scraper (Self Propelled or Tractor Drawn) 5cu yards or more capacity; Power Subgrader; Asphalt Milling Machine; Boring Machine (Horizontal, Vertical or Directional); Air Track, Rotary or Percussion Drilling Machine; Trencher; Post Hole Digger or Driver; Tug or Launch (not performing work on the Great Lakes)	28.12	15.73	43.85
Farm or Industrial Type Tractor; Greaser; Compactor (Self-Propelled); Broom or Sweeper; Environmental Burner	28.59	16.00	44.59
Crusher, Screening or Wash Plant; Air Compressor (400 CFM or Over); Pump (3 Inch or Over) or Well Points; Refrigeration Plant or Freeze Machine; Skid Steer Loader (With or Without Attachments); Skid Rig; Stump Chipper; Mulcher; Vibratory Hammer or Extractor	27.59	14.88	42.47

**HEAVY EQUIPMENT OPERATORS****EXCLUDING SITE PREPARATION, UTILITY, PAVING AND LANDSCAPING WORK**

Crane, Tower Crane or Derrick, With or Without Attachments, With a Lifting Capacity of Over 100 Tons; Crane, Tower Crane or Derrick, With Boom, Leads and/or Jib Lengths Measuring 176 Feet or Over	30.62	16.00	46.62
Premium Pay: Add \$.50/hr for cranes with lifting capacity over 200 ton; Add \$1.00/hr. at 300 ton; Add \$1.50/hr at 400 ton; Add \$2.00/hr at 500 ton.			
Crane, Tower Crane or Derrick, With or Without Attachments, With a Lifting	29.62	16.00	45.62

**Fringe Benefits Must Be Paid On All Hours Worked**

<u>TRADE OR OCCUPATION</u>	<u>HOURLY BASIC RATE OF PAY</u>	<u>HOURLY FRINGE BENEFITS</u>	<u>TOTAL</u>
	\$	\$	\$
Capacity of 100 Tons or Under; Crane, Tower Crane or Derrick, With Boom, Leads and/or Jib Lengths Measuring 175 Feet or Under; Backhoe (Track Type) Having a Mfgr.'s Rated Capacity of 130,000 Lbs. or Over; Traveling Crane (Bridge Type); Caisson Rig; Pile Driver; Dredge (Not Performing Work on the Great Lakes) Future Increase(s): Premium Pay: Add \$.25/hr for cranes with lifting capacity of 45 ton or over			
Crane (Go-Devil Type) or Truck Mounted Hydraulic Crane (10 Tons or Under); Backhoe (Track Type) Having a Mfgr.'s Rated Capacity of Under 130,000 Lbs.; Tractor or Truck Mounted Hydraulic Backhoe; Gradall (Cruz-Aire Type); Mechanic or Welder; Bulldozer or Endloader; Grader or Motor Patrol; Scraper (Self Propelled or Tractor Drawn) 5 cu yards or more capacity; Concrete Pump, Grout Pump or Concrete Conveyor (Rotec or Bidwell Type); Concrete Breaker (Manual or Remote); Concrete Batch Plant; Power Subgrader; Concrete Spreader; Concrete Paver; Concrete Grinder or Planing Machine; Concrete Conveyor System; Concrete Slipform Placer; Curb and Gutter Machine; Roller (Over 5 Ton); Shouldering Machine; Boring Machine (Horizontal, Vertical or Directional); Air Track, Rotary or Percussion Drilling Machine; Straddle Carrier or Travel Lift; Forklift (Machinery Moving or Steel Erection); Manhoist or Elevator; Material or Stack Hoist; Trencher; Sideboom; Hydro-Blaster (10,000 PSI or Over); Post Hole Digger or Driver; Railroad Track Rail Leveling Machine, Tie Placer, Extractor, Tamper, Stone Leveler or Rehabilitation Equipment Future Increase(s):	29.12	16.00	45.12
Farm or Industrial Type Tractor; Greaser; Compactor (Self-Propelled); Concrete Saw (Vermeer Type); Concrete Bump Cutter or Grooving Machine; Tining or Curing Machine; Roller (5 Tons or Under); Broom or Sweeper; Hoist (Tugger); Environmental Burner	22.98	6.02	29.00
Crusher, Screening or Wash Plant; Air, Electric or Hydraulic Jacking System; Air Compressor (400 CFM or Over); Generator (150 KW or Over); Pump (3 Inch or Over) or Well Points; Refrigeration Plant or Freeze Machine; Skid Steer Loader (With or Without Attachments); Robotic Tool Carrier (With or Without Attachments); Skid Rig; Stump Chipper; Mulcher; Vibratory Hammer or Extractor	28.87	14.90	43.77
Oiler; Forklift	25.89	16.00	41.89
Gas or Utility Pipeline, Except Sewer and Water (Primary Equipment)	31.57	17.23	48.80
Gas or Utility Pipeline, Except Sewer and Water (Secondary Equipment)	28.12	15.40	43.52
Fiber Optic Cable Equipment	25.33	12.35	37.68

This document **MUST BE POSTED** by the **CONTRACTING AGENCY** in at least one conspicuous and easily accessible place **on the site of the project**. A local governmental unit may post this document at the place normally used to post public notices if there is no common site on the project. This document **MUST** remain posted during the entire time any worker is employed on the project and **MUST** be physically incorporated into the specifications and all contracts and most subcontracts. If you have any questions, please write to the Equal Rights Division, Labor Standards Bureau, P.O. Box 8928, Madison, Wisconsin 53708 or call (608) 266-3148.

**The following statutory provisions apply to local governmental unit public works projects and are set forth below pursuant to the requirements of s. 66.0903 (8), Stats.**

Each contractor, subcontractor or agent thereof performing work on a project that is subject to this section shall keep full and accurate records clearly indicating the name and trade or occupation of every person described in sub. (4) and an accurate record of the number of hours worked by each of those persons and the actual wages paid therefor.

Any contractor, subcontractor or agent thereof, who fails to pay the prevailing wage rate determined by the department under sub.(3) or who pays less than 1.5 times the hourly basic rate of pay for all hours worked in excess of the prevailing hours of labor determined under sub.(3), shall be liable to any affected employe in the amount of his or her unpaid wages or his or her unpaid overtime compensation and in an additional equal amount as liquidated damages. An action to recover the liability may be maintained in any court of competent jurisdiction by any employe for and in behalf of that employe and other employes similarly situated. No employe may be a party plaintiff to any such action unless the employe consents in writing to become such a party and the consent is filed in the court in which the action is brought. Notwithstanding s. 814.04 (1), the court shall, in addition to any judgment awarded to the plaintiff, allow reasonable attorney fees and costs to be paid by the defendant.

Consolidated List of Debarred Contractors  
Prepared and Issued By  
State of Wisconsin  
Department of Workforce Development

February 1, 2007

This list has been prepared in accordance with the provisions of s. 66.0903(12) and s. 103.49(7), Stats. and Chapter DWD 294 of the Wisconsin Administrative Code. All contractors on this list were found to have committed a "debarable offense" related to certain labor standard provisions determined or established for a state or local public works project. No state agency or local governmental unit may knowingly solicit bids from, negotiate with or award any contracts to or approve or allow any subcontractors with a debarred contractor, including all divisions, affiliates or other organizational elements of such contractor that are engaged in construction business activities, until the debarment is terminated. The name of each debarred contractor must remain on this list for a period of three (3) years from the termination date indicated below. The contractor is, however, only "debarred" from the "effective date" through the "termination date" indicated for that contractor. Questions regarding this list should be addressed to Mike Dixon, Equal Rights Division, P. O. Box 8928, Madison, WI 53708 or call (608) 266-0028. Deaf, hearing or speech-impaired callers may contact the department by calling its TDD number (608) 264-8752.

<u>Name of Contractor</u>	<u>Address</u>	<u>Effective Date</u>	<u>Termination Date</u>	<u>Cause Code</u>	<u>Date of Violation(s)</u>	<u>Limitations/Deviations</u>
Bay Asphalt, Inc.	1792 Scray Hill Road De Pere, WI 54115	1/1/03	12/31/05	1, 2 and 4	1997- 1999	None
Bechitsao, Joel	See Tri-State Traffic Services, Inc.					
B.P. Phillips Construction, Inc.	1570 Fire Lane Drive Green Bay, WI 54311	9/19/01	9/18/04	1, 2 and 4	4/7/97 to 3/7/98	None
Custom Heating & Air LLC	283 Tony Lane, Green Bay, WI 54304	12/1/06	11/30/09	1, 2 and 4	2003 to 2004	None
D. C. Nevels Trucking, Inc. or D. C. Nevels Trucking	3246 North Sherman Blvd., Milwaukee, WI 53216	6/1/05	5/31/08	1, 2 and 4	2000- 2002	None
Gibraltar Construction LLC	N60 W15080 Bobolink Ave., Menomonee Falls, WI 53051	12/1/06	4/30/07	1	2005	None
HGI Painting	P. O. Box 3481, Janesville, WI 53545	11/1/04	10/31/07	1, 2 and 4	2001, 2002 and 2003	None
Haim, James	See Haim Painting, Inc.					

<u>Name of Contractor</u>	<u>Address</u>	<u>Effective Date</u>	<u>Termination Date</u>	<u>Cause Code</u>	<u>Date of Violation(s)</u>	<u>Limitations/Deviations</u>
Haim Painting, Inc.	N15 W22120 Jerico Drive, #8 Waukesha, WI 53186	4/1/01	3/31/04	1, 2 and 4	7/6/97 to 10/30/98	None
Hedding, Matt	C/O HGI Painting, P. O. Box 3481, Janesville, WI 53545	11/1/04	10/31/07	1, 2 and 4	2001, 2002 and 2003	None
Jacobi, Sandi	See Wisconsin Detention Systems, Inc.					
Jacobi Sr., Michael A.	See Wisconsin Detention Systems, Inc.					
Joseph Stoller Company	N8426 Hwy 42	2/1/2007	1/31/2010	1, 2	2004 and 2005	None
J. R. Electric	2391 233 <sup>rd</sup> St., P. O. Box 491, Cushing, WI 54006	1/1/03	12/31/05	1 and 2	1999	None
J. R. Electric, Inc.	2391 233 <sup>rd</sup> St., P. O. Box 491, Cushing, WI 54006	1/1/03	12/31/05	1 and 2	1999	None
Keiver, David	See Custom Heating & Air LLC	12/1/06	11/30/09	1, 2 and 4	2003 and 2004	None
Kietschka, Richard	See J. R. Electric and J. R. Electric, Inc.					
Kietschka, Tristan	See J. R. Electric, Inc.					
Kruczek Construction, Inc.	3636 Kewaunee Road, Green Bay, WI 54311	6/1/05	11/30/05	1 and 2	1998 and 1999	None
Kruczek, John	See Kruczek Construction, Inc.					
LaCosse, Todd	See Midwest Contractors, Inc.					

<u>Name of Contractor</u>	<u>Address</u>	<u>Effective Date</u>	<u>Termination Date</u>	<u>Cause Code</u>	<u>Date of Violation(s)</u>	<u>Limitations/Deviations</u>
Maria, Steve	See Gibraltar Construction LLC					
Mellendez, Odillion	See Amigo Painting					
Midwest Contractors, Inc.	2100 Depot St., Holt, MI 48842	6/21/02	6/20/05	1	6/11/99 to 12/31/99	None
Nevels, Betty	See D. C. Nevels Truckng, Inc.					
Nevels, Donald	See D. C. Nevels Trucking, Inc.					
Phillips, Bruce P.	See B.P. Phillips Construction					
Rick's Painting & Drywall	P. O. Box 2316, Eagle River, WI 54521	3/1/03	2/28/06	1	5/8/00 to 4/30/01	None
Scandia Heating and Air Conditioning, Inc.	P. O. Box 7 Scandia, MN. 55703	5/1/2003	4/30/2004	1 and 2	2001	None
Stoller Enterprises LLC	N8426 Hwy 42, Algoma, WI 54201-9552	2/1/2007	1/31/2010	1 and 2	2005 to 2006	None
Stoller, Joseph	See Joseph Stoller Company					
Stoller, Patrick J.	See Stoller Enterprises LLC					
Strobel Construction, Inc..	P. O. Box 2316, Eagle River, WI 54521	3/1/03	2/28/06	1	5/8/00 to 4/30/01	None
Strobel, Diane	See Strobel Construction, Inc.					
Strobel, Rick	See Strobel Construction, Inc.					
Tri-State Traffic Services, Inc.	12555 West Burleigh Road #3, Brookfield, WI 53005	12/1/06	11/30/07	1, 2 and 4	2003- 2004	None

<u>Name of Contractor</u>	<u>Address</u>	<u>Effective Date</u>	<u>Termination Date</u>	<u>Cause Code</u>	<u>Date of Violation(s)</u>	<u>Limitations/Deviations</u>
Wanta, Daniel	See Bay Asphalt, Inc.					
Wisconsin Detention Systems, Inc	.W204 N16635 Jackson Drive Jackson, Wisconsin 53037	1/1/03	12/31/05	1	9/2000 to 3/2001	None
West, James F.	See Scandia Heating and Air Conditioning, Inc.					
Zinke, Stacy	See Talex Contractors, Inc.					

Cause Code: 1 = Failure to Pay Straight Time 2 = Failure to Pay Overtime 3 = Kickback 4 = Payroll Records.

## Disclosure of Ownership

**Notice required under Section 15.04(1)(m), Wisconsin Statutes.** The statutory authority for the use of this form is prescribed in Sections 66.0903(12)(d) and 103.49(7)(d), Wisconsin Statutes. The use of this form is mandatory. The penalty for failing to complete this form is prescribed in Section 103.005(12), Wisconsin Statutes. Personal information you provide may be used for secondary purposes

- (1) On the date a contractor submits a bid to or completes negotiations with a state agency or local governmental unit, on a project subject to Section 66.0903 or 103.49, Wisconsin Statutes, the contractor shall disclose to such state agency or local governmental unit the name of any "other construction business", which the contractor, or a shareholder, officer or partner of the contractor, owns or has owned within the preceding three (3) years.
- (2) The term "other construction business" means any business engaged in the erection, construction, remodeling, repairing, demolition, altering or painting and decorating of buildings, structures or facilities. It also means any business engaged in supplying mineral aggregate, or hauling excavated material or spoil as provided by Sections 66.0903(3), 103.49(2) and 103.50(2), Wisconsin Statutes.
- (3) This form must **ONLY** be filed, with the state agency or local governmental unit that will be awarding the contract, if **both (A) and (B) are met.**
  - (A) The contractor, or a shareholder, officer or partner of the contractor:
    - (1) Owns at least a 25% interest in the "other construction business", indicated below, on the date the contractor submits a bid or completes negotiations.
    - (2) Or has owned at least a 25% interest in the "other construction business" at any time within the preceding three (3) years.
  - (B) The Wisconsin Department of Workforce Development (DWD) has determined that the "other construction business" has failed to pay the prevailing wage rate or time and one-half the required hourly basic rate of pay, for hours worked in excess of the prevailing hours of labor, to any employee at any time within the preceding three (3) years.

### Other Construction Business

Name of Business

Street Address or P O Box

City

State

Zip Code

Name of Business

Street Address or P O Box

City

State

Zip Code

Name of Business

Street Address or P O Box

City

State

Zip Code

Name of Business

Street Address or P O Box

City

State

Zip Code

**I hereby state under penalty of perjury that the information, contained in this document, is true and accurate according to my knowledge and belief.**

Print the Name of Authorized Officer

Signature of Authorized Officer

Date Signed

Name of Corporation, Partnership or Sole Proprietorship

Street Address

City

State

Zip Code

**If you have any questions call (608) 266-0028**



## DISCLAIMER

Effective May 1, 2007 employers performing work on public works construction projects in Wisconsin for municipal government and state building projects will be required to have a written substance abuse testing program in place. The provisions of this requirement are contained in Act 181. The Department of Workforce Development is not responsible for enforcement of this law or authorized to answer questions concerning the provisions of Act 181. For legal advice on complying with Act 181 you may wish to consult with a private attorney.

2005 Assembly Bill 736

Date of enactment: March 22, 2006

Date of publication\*: April 5, 2006

# 2005 WISCONSIN ACT 181

**AN ACT** to create 103.503 of the statutes; relating to: substance abuse by employees who are required to be paid the prevailing wage rate for work performed on projects of public works, other than state highway projects.

*The people of the state of Wisconsin, represented in senate and assembly, do enact as follows:*

SECTION 1. 103.503 of the statutes is created to read:  
103.503 Substance abuse prevention on public works projects. (1) DEFINITIONS. In this section:

(a) "Accident" means an incident caused, contributed to, or otherwise involving an employee that resulted or could have resulted in death, personal injury, or property damage and that occurred while the employee was performing the work described in s. 66.0903 (4) or 103.49 (2m) on a project.

(b) "Alcohol" has the meaning given in s. 340.01 (1q).

(c) "Contracting agency" means a local governmental unit, as defined in s. 66.0903 (1) (d), or a state agency, as defined in s. 103.49 (1) (f), that has contracted for the performance of work on a project.

(d) "Drug" means any controlled substance, as defined in s. 961.01 (4), or controlled substance analog, as defined in s. 961.01 (4m), for which testing is required by an employer under its substance abuse prevention program under this section.

(e) "Employee" means a laborer, worker, mechanic, or truck driver who performs the work described in s. 66.0903 (4) or 103.49 (2m) on a project.

(f) "Employer" means a contractor, subcontractor, or agent of a contractor or subcontractor that performs work on a project.

(g) "Project" means a project of public works that is subject to s. 66.0903 or 103.49.

(2) SUBSTANCE ABUSE PROHIBITED. No employee may use, possess, attempt to possess, distribute, deliver, or be under the influence of a drug, or use or be under the influence of alcohol, while performing the work described in s. 66.0903 (4) or 103.49 (2m) on a project. An employee is considered to be under the influence of alcohol for purposes of this subsection if he or she has an alcohol concentration that is equal to or greater than the amount specified in s. 885.235 (1g) (d).

(3) SUBSTANCE ABUSE PREVENTION PROGRAMS REQUIRED. (a) Before an employer may commence work on a project, the employer shall have in place a written program for the prevention of substance abuse among its employees. At a minimum, the program shall include all of the following:

1. A prohibition against the actions or conditions specified in sub. (2).

2. A requirement that employees performing the work described in s. 66.0903 (4) or 103.49 (2m) on a project submit to random, reasonable suspicion, and post-accident drug and alcohol testing and to drug and alcohol

\* Section 991.11, WISCONSIN STATUTES 2003-04: Effective date of acts. "Every act and every portion of an act enacted by the legislature over the governor's partial veto which does not expressly prescribe the time when it takes effect shall take effect on the day after its date of publication as designated" by the secretary of state [the date of publication may not be more than 10 working days after the date of enactment].

testing before commencing work on a project, except that testing of an employee before commencing work on a project is not required if the employee has been participating in a random testing program during the 90 days preceding the date on which the employee commenced work on the project.

3. A procedure for notifying an employee who violates sub. (2), who tests positive for the presence of a drug in his or her system, or who refuses to submit to drug or alcohol testing as required under the program that the employee may not perform work on a project until he or she meets the conditions specified in sub. (4) (b) 1. and 2.

(b) Each employer shall be responsible for the cost of developing, implementing, and enforcing its substance abuse prevention program, including the cost of drug and alcohol testing of its employees under the program. The contracting agency is not responsible for that cost, for the cost of any medical review of a test result, or for any rehabilitation provided to an employee.

(4) EMPLOYEE ACCESS TO PROJECT. (a) No employer may permit an employee who violates sub. (2), who tests positive for the presence of a drug in his or her system, or who refuses to submit to drug or alcohol testing as required under the employer's substance abuse prevention program under sub. (3) to perform work on a project until he or she meets the conditions specified in par. (b) 1. and 2. An employer shall immediately remove an employee from work on a project if any of the following occurs:

1. The employee violates sub. (2), tests positive for the presence of a drug in his or her system, or refuses to submit to drug or alcohol testing as required under the employer's substance abuse prevention program.

2. An officer or employee of the contracting agency has a reasonable suspicion that the employee is in violation of sub. (2) and requests the employer to immediately remove the employee from work on the project.

(b) An employee who is barred or removed from work on a project under par. (a) may commence or return to work on the project upon his or her employer providing to the contracting agency documentation showing all of the following:

1. That the employee has tested negative for the presence of drugs in his or her system and is not under the influence of alcohol as described in sub. (2).

2. That the employee has been approved to commence or return to work on the project in accordance with the employer's substance abuse prevention program.

(c) Testing for the presence of drugs or alcohol in an employee's system and the handling of test specimens shall be conducted in accordance with guidelines for laboratory testing procedures and chain-of-custody procedures established by the substance abuse and mental health services administration of the federal department of health and human services.

(5) LOCAL ORDINANCES; STRICT CONFORMITY REQUIRED. A local governmental unit, as defined in s. 66.0903 (1) (d), may enact an ordinance regulating the conduct regulated under this section only if the ordinance strictly conforms to this section.

#### SECTION 2. Initial applicability.

(1) This act first applies to a contract to perform work on a project, as defined in section 103.503 (1) (g) of the statutes, as created by this act, for which bids are opened on the effective date of this subsection or, if bids are not solicited for the contract, to a contract to perform such work entered into on the effective date of this subsection, except that this This act first applies to an employee who is affected by a collective bargaining agreement that contains provisions inconsistent with this act on the day on which the collective bargaining agreement expires or is extended, modified, or renewed, whichever occurs first.

#### SECTION 3. Effective date.

(1) This act takes effect on the first day of the 13th month beginning after publication.

# Prime Contractor Affidavit of Compliance With Prevailing Wage Rate Determination

**NOTICE REQUIRED UNDER Section 15.04(1) (m), Wisconsin Statutes.** Authorization for this form is provided under Sections, 66.0903(9) (b) and 103.49(4r) (9b) Wisconsin Statutes. The use of this form is mandatory. The penalty for failing to complete this form is prescribed in Section 103.005(12), Wisconsin Statutes. Personally identifiable information may be used for secondary purposes.

This form must **ONLY** be filed with the **Awarding Agency** indicated below.

State Of _____ ) )SS County Of _____ )	Project Name		
	Project Number		Determination Number
	Date Determination Issued		Date of Contract
	Awarding Agency		
	Date Work Completed		

After being duly sworn, the person whose name and signature appears below hereby states under penalty of perjury that

- **I am** the duly authorized officer of the corporation, partnership, sole proprietorship or business indicated below and have recently completed all of the work required under the terms and conditions of a contract with the above-named awarding agency and make this affidavit in accordance with the requirements set forth in Section 66.0903(9)(c) or 103.49(4r)(c), Wisconsin Statutes and Chapter DWD 290 of the Wisconsin Administrative Code in order to obtain FINAL PAYMENT from such awarding agency.
- **I have** fully complied with all of the wage and hour requirements applicable to this project, including all of the requirements set forth in the prevailing wage rate determination indicated above which was issued for such project by the Department of Workforce Development on the date indicated above.
- **I have** received the required affidavit of compliance from each of my agents and subcontractors that performed work on this project and have listed each of their names and addresses on page 2 of this affidavit.
- **I have** full and accurate records that clearly indicate the name and trade or occupation of every worker(s) that I employed on this project, including an accurate record of the hours worked and actual wages paid to such worker(s).
- **I will** retain the records and affidavit(s) described above and make them available for inspection for a period of at least three (3) years from the completion date indicated above at the address indicated below and shall not remove such records or affidavit(s) without prior notification to the awarding agency indicated above.

Name of Corporation, Partnership, Sole Proprietorship or Business				
Street Address or P O Box		City	State	Zip Code (    )
Print Name of Authorized Officer			Date Signed	
Signature of Authorized Officer				

## List of Agents and Subcontractors

Name			Name		
Street Address			Street Address		
City	State	Zip Code	City	State	Zip Code
Telephone Number (    )			Telephone Number (    )		
Name			Name		
Street Address			Street Address		
City	State	Zip Code	City	State	Zip Code
Telephone Number (    )			Telephone Number (    )		
Name			Name		
Street Address			Street Address		
City	State	Zip Code	City	State	Zip Code
Telephone Number (    )			Telephone Number (    )		
Name			Name		
Street Address			Street Address		
City	State	Zip Code	City	State	Zip Code
Telephone Number (    )			Telephone Number (    )		
Name			Name		
Street Address			Street Address		
City	State	Zip Code	City	State	Zip Code
Telephone Number (    )			Telephone Number (    )		
Name			Name		
Street Address			Street Address		
City	State	Zip Code	City	State	Zip Code
Telephone Number (    )			Telephone Number (    )		
Name			Name		
Street Address			Street Address		
City	State	Zip Code	City	State	Zip Code
Telephone Number (    )			Telephone Number (    )		

**If you have any questions call (608) 266-6861**

## Agent or Subcontractor Affidavit of Compliance With Prevailing Wage Rate Determination

**NOTICE REQUIRED UNDER Section 15.04(1)(m), Wisconsin Statutes.** Authorization for this form is provided under Sections, 66.0903(9)(b) and 103.49(4r)(9b) Wisconsin Statutes. The use of this form is mandatory. The penalty for failing to complete this form is prescribed in Section 103.005(12), Wisconsin Statutes. Personally identifiable information may be used for secondary purposes.

This form must **ONLY** be filed with the **Awarding Contractor** indicated below.

State Of _____ )  )SS  County Of _____ )	Project Name	
	Project Number	Determination Number
	Date Determination Issued	Date of Subcontract
	Awarding Contractor	
	Date Work Completed	

After being duly sworn, the person whose name and signature appears below hereby states under penalty of perjury that

- **I am** the duly authorized officer of the corporation, partnership, sole proprietorship or business indicated below. We have recently completed all of the work required under the terms and conditions of a subcontract with the above-named awarding contractor. We make this affidavit in accordance with the requirements set forth in Section 66.0903(9)(b) or 103.49(4r)(b), Wisconsin Statutes and Chapter DWD 290 of the Wisconsin Administrative Code in order to obtain FINAL PAYMENT from such awarding contractor.
- **I have** fully complied with all of the wage and hour requirements applicable to this project, including all of the requirements set forth in the prevailing wage rate determination indicated above which was issued for such project by the Department of Workforce Development on the date indicated above.
- **I have** received the required affidavit of compliance from each of my agents and subcontractors that performed work on this project and have listed each of their names and addresses on page 2 of this affidavit.
- **I have** full and accurate records that clearly indicate the name and trade or occupation of every worker(s) that I employed on this project, including an accurate record of the hours worked and actual wages paid to such worker(s).
- **I will** retain the records and affidavit(s) described above and make them available for inspection for a period of at least three (3) years from the completion date indicated above at the address indicated below and shall not remove such records or affidavit(s) without prior notification to the awarding contractor.

Name of Corporation, Partnership, Sole Proprietorship or Business				
Street Address	City	State	Zip Code	Telephone Number (     )
Print Name of Authorized Officer			Date Signed	
Signature of Authorized Officer				

Name			Name		
Street Address			Street Address		
City	State	Zip Code	City	State	Zip Code
Telephone Number (    )			Telephone Number (    )		
Name			Name		
Street Address			Street Address		
City	State	Zip Code	City	State	Zip Code
Telephone Number (    )			Telephone Number (    )		
Name			Name		
Street Address			Street Address		
City	State	Zip Code	City	State	Zip Code
Telephone Number (    )			Telephone Number (    )		
Name			Name		
Street Address			Street Address		
City	State	Zip Code	City	State	Zip Code
Telephone Number (    )			Telephone Number (    )		
Name			Name		
Street Address			Street Address		
City	State	Zip Code	City	State	Zip Code
Telephone Number (    )			Telephone Number (    )		
Name			Name		
Street Address			Street Address		
City	State	Zip Code	City	State	Zip Code
Telephone Number (    )			Telephone Number (    )		

If you have any questions call (608) 266-0028

# Request To Employ Subjourneyperson

Personal information you provide may be used for secondary purposes. [See Section 15.04(1)(m), Wisconsin Statutes for details.] The use of this form is mandatory. The authority for the use of this form is prescribed in Section DWD 290.025, Wisconsin Administrative Code. The penalty for failing to complete this form is prescribed in Section 103.005(12), Wisconsin Statutes.

The employer indicated below requests that the Department of Workforce Development (DWD) determine the prevailing wage rate(s) and related qualifications to enable such employer to utilize a subjourneyperson(s) on the following public works project, in accordance with the provisions of Section DWD 290.025, Wisconsin Administrative Code.

<b>1. Name of Public Works Project</b>	
County	City, Village or Township
Determination Number	Project Number

2. Name of Employee (Last, First and Initial)	P. O. Box or Street Address	City	State	Zip Code	Date of Birth	Journey Classification

<b>3. Name of Employer (Print)</b>		
Name of Person Making Request (Print)	City	State
P O Box or Street Address	City	Zip Code
Telephone Number (     )	Title of Requestor	

**READ CAREFULLY:** I fully understand that this request is ONLY applicable to the project and employee(s) listed above and that such employee(s) will ONLY work under the direction of and directly assist a skilled trades employee by frequently using the tools of a skilled trades employee and will NOT regularly perform the duties of a general laborer, heavy equipment operator or truck driver. If the employee(s) indicated above regularly perform(s) the work of a different trade or occupation, he/she will be compensated for such work at the applicable journeypersons prevailing wage rate. I agree not to employ any employee as a subjourneyperson on this project until I receive written confirmation from the DWD. After such confirmation is received, I will compensate the employee(s) indicated above in strict accordance with the directions received from the DWD.

Signature of Requestor \_\_\_\_\_ Date Signed \_\_\_\_\_

**MAIL COMPLETED REQUEST TO Equal Rights Division, Labor Standards Bureau, P. O. Box 8928 Madison WI 53708.**

You may call (608) 266-6860 if you need assistance in completing your request

1 **SECTION 01 10 00 - BASIC REQUIREMENTS**

2  
3 PART 1 - GENERAL

4 1.1 SECTION SUMMARY

- 5 A. Section Includes:
- 6 1. Section Summary
  - 7 2. Summary of the Work
  - 8 3. Contractor Use of Premises
  - 9 4. Applications for Payment
  - 10 5. Alternates
  - 11 6. Coordination
  - 12 7. Cutting and Patching
  - 13 8. Conferences
  - 14 9. Progress Meetings
  - 15 10. Submittal Procedures
  - 16 11. Proposed Products List
  - 17 12. Shop Drawings
  - 18 13. Product Data
  - 19 14. Samples
  - 20 15. Manufacturers' Instructions
  - 21 16. Manufacturers' Certificates
  - 22 17. Quality Assurance / Quality Control of Installation
  - 23 18. References
  - 24 19. Interior Enclosures
  - 25 20. Protection of Installed Work
  - 26 21. Parking
  - 27 22. Progress Cleaning
  - 28 23. Products
  - 29 24. Transportation, Handling, Storage and Protection
  - 30 25. Product Options
  - 31 26. Substitutions
  - 32 27. Starting Systems
  - 33 28. Demonstration and Instructions
  - 34 29. Contract Closeout Procedures
  - 35 30. Final Cleaning
  - 36 31. Adjusting
  - 37 32. Operation and Maintenance Data
  - 38 33. Spare Parts and Maintenance Materials
  - 39 34. As-Built Drawings and Specifications

40 1.2 SUMMARY OF THE WORK

- 41 A. Project Description: Perform the Work as specified and detailed in Construction  
42 Documents package. Contractor to provide all labor and materials to remove  
43 approximately 80,000 sq. ft of existing EPDM roofing and insulation; and replace with 60  
44 mil EPDM and polyisocyanurate insulation.
- 45 B. Work by Owner: Not applicable.



1 C. Permits: Prior to commencement of the Work, Contractor to secure any and all  
2 necessary permits for completion of the Work and facility occupancy.

3 1.3 CONTRACTOR USE OF PREMISES

4 A. Limit use of premises to allow work by Contractors or Subcontractors and access by  
5 Owner.

6 1.4 . APPLICATIONS FOR PAYMENT

7 A. Submit two (2) copies of each application on AIA G702™ and G703™ forms or approved  
8 contractors invoice form.

9 B. Content and Format: Utilize Schedule of Values for listing items in Application for  
10 Payment.

11 C. Payment Period: Monthly.

12 1.5 ALTERNATES

13 A. Alternates quoted on Bid Form shall be reviewed and accepted or rejected at the Owner's  
14 option.

15 B. Coordinate related work and modify surrounding work as required.

16 C. Schedule of Alternates:

17 1. Alternate Bid 1 .

18 a. Substitute White Thermoplastic Polyolefin (TPO) single ply membrane in  
19 lieu of the EPDM membrane

20 2. Alternate Bid 2 .

21 a. Unit pricing to replace the parapet batt insulation and vertical parapet  
22 sheathing ( on the roof side).

23 1.6 COORDINATION

24 A. Coordinate scheduling, submittals, and work of various sections of Specifications to  
25 assure efficient and orderly sequence of installation of interdependent construction  
26 elements.

27 B. Verify utility requirement characteristics of operating equipment are compatible with  
28 building utilities.

29 C. Coordinate space requirements and installation of mechanical and electrical work that are  
30 indicated diagrammatically on Drawings.

31 1.7 CUTTING AND PATCHING

32 A. Employ a skilled and experienced installer to perform cutting and patching new work;  
33 restore work with new Products.

34 B. Submit written request in advance of cutting or altering structural or building enclosure  
35 elements.

- 1 C. Fit work tight to adjacent elements. Maintain integrity of wall, ceiling, or floor construction;  
2 completely seal voids.
- 3 D. Refinish surfaces to match adjacent finishes.
- 4 1.8 CONFERENCES
- 5 A. Dane County Department Public Works, Highway & Transportation will schedule a  
6 preconstruction conference after Award of Contract for all affected parties.
- 7 B. When required in individual Specification section, convene a pre-installation conference  
8 at project site prior to commencing work of the section.
- 9 1.9 PROGRESS MEETINGS
- 10 A. Owner shall schedule and administer meetings throughout progress of the Work at  
11 minimum of one (1) per week.
- 12 B. Owner shall preside at meetings, record minutes, and distribute copies within two (2)  
13 days to those affected by decisions made.
- 14 1.10 SUBMITTAL PROCEDURES
- 15 A. Submittal form to identify Project, Contractor, Subcontractor or supplier; and pertinent  
16 Construction Documents references.
- 17 B. Apply Contractor's stamp, signed or initialed, certifying that review, verification of  
18 Products required, field dimensions, adjacent construction work, and coordination of  
19 information is in accordance with requirements of the Work and Construction Documents.
- 20 C. Identify variations from Construction Documents and Product or system limitations that  
21 may be detrimental to successful performance of completing the Work.
- 22 D. Revise and resubmit submittals as required; identify all changes made since previous  
23 submittal.
- 24 1.11 PROPOSED PRODUCTS LIST
- 25 A. Within fifteen (15) days after date of Award of Contract, submit complete list of major  
26 Products proposed for use, with name of manufacturer, trade name, and model number  
27 of each Product.
- 28 1.12 SHOP DRAWINGS
- 29 A. Submit number of copies that Contractor requires, plus two (2) copies that shall be  
30 retained by Public Works Project Manager.
- 31 1.13 PRODUCT DATA
- 32 A. Submit number of copies that Contractor requires, plus two (2) copies that shall be  
33 retained by Public Works Project Manager.
- 34 B. Mark each copy to identify applicable products, models, options, and other data.  
35 Supplement manufacturer's standard data to provide information unique to this Project.

- 1 1.14 SAMPLES
- 2 A. Submit samples to illustrate functional and aesthetic characteristics of the Product.
- 3 B. Submit samples of finishes from the full range of manufacturers' standard colors,  
4 textures, and patterns for Public Works Project Engineer's selection.
- 5 1.15 MANUFACTURERS' INSTRUCTIONS
- 6 A. When specified in individual Specification sections, submit manufacturers' printed  
7 instructions for delivery, storage, assembly, installation, start-up, adjusting, and finishing,  
8 in quantities specified for Product Data.
- 9 1.16 MANUFACTURERS' CERTIFICATES
- 10 A. When specified in individual Specification sections, submit manufacturers' certificate to  
11 Public Works Project Engineer for review, in quantities specified for Product Data.
- 12 B. Indicate material or Product conforms to or exceeds specified requirements. Submit  
13 supporting reference data, affidavits, and certifications as appropriate.
- 14 1.17 QUALITY ASSURANCE / QUALITY CONTROL OF INSTALLATION
- 15 A. Monitor quality control over suppliers, manufacturers, Products, services, site conditions,  
16 and workmanship, to produce work of specified quality.
- 17 B. Comply fully with manufacturers' instructions.
- 18 C. Comply with specified standards as minimum quality for the Work except when more  
19 stringent tolerances, codes, or specified requirements indicate higher standards or more  
20 precise workmanship.
- 21 1.18 REFERENCES
- 22 A. Conform to reference standard by date of issue current as of date for receiving bids.
- 23 B. Should specified reference standard conflict with Construction Documents, request  
24 clarification from Public Works Project Engineer before proceeding.
- 25 1.19 INTERIOR ENCLOSURES
- 26 A. Provide temporary partitions as required to separate work areas from Owner occupied  
27 areas, to prevent distribution of dust and moisture into Owner occupied areas, and to  
28 prevent damage to existing materials and equipment.
- 29 1.20 PROTECTION OF INSTALLED WORK
- 30 A. Protect installed work and provide special protection where specified in individual  
31 Specification sections.
- 32 1.21 PARKING
- 33 A. Arrange for temporary parking areas to accommodate construction personnel. Parking  
34 shall be available at the Work site.

- 1 1.22 PROGRESS CLEANING
- 2 A. Maintain areas free of waste materials, debris, and rubbish. Maintain site in clean and  
3 orderly condition.
- 4 1.23 PRODUCTS
- 5 A. Products: Means new material, machinery, components, equipment, fixtures, and  
6 systems forming the Work, but does not include machinery and equipment used for  
7 preparation, fabrication, conveying and erection of the Work. Products may also include  
8 existing materials or components specifically identified for reuse.
- 9 B. Do not use materials and equipment removed from existing premises, except as  
10 specifically identified or allowed by Construction Documents.
- 11 1.24 TRANSPORTATION, HANDLING, STORAGE AND PROTECTION
- 12 A. Transport, handle, store and protect Products in accordance with manufacturer's  
13 instructions.
- 14 1.25 PRODUCT OPTIONS
- 15 A. Where definite material is specified, it is not intention to discriminate against "equal"  
16 product made by another manufacturer. Intention is to set definite standard of material  
17 quality. Should bidder choose to bid materials other than those specified, bidder shall  
18 submit said materials specifications to Department Public Works, Highway &  
19 Transportation for approval at least five (5) days prior to Bid Opening.
- 20 B. Products and materials that are not specified, but have been approved for use by Public  
21 Works Project Engineer shall be identified in addenda to all bidding contractors.
- 22 C. Requests for material or product substitutions submitted after Bid Opening maybe  
23 considered. Dane County reserves right to approve or reject substitutions based on  
24 Specification requirements and intended use.
- 25 1.26 SUBSTITUTIONS
- 26 A. Public Works Project Engineer shall consider requests for Substitutions only up to five(5)  
27 days prior to date of Bid Opening.
- 28 B. Document each request with complete data substantiating compliance of proposed  
29 Substitution with Construction Documents.
- 30 C. Submit three (3) copies of requests for Substitution for consideration. Limit each request  
31 to one (1) proposed Substitution.
- 32 D. Substitutions shall not change contract price established at Bid Opening.
- 33 1.27 STARTING SYSTEMS
- 34 A. Provide written notification prior to start-up of each equipment item or system.
- 35 B. Ensure that each piece of equipment or system is ready for operation.

- 1 C. Execute start-up under supervision of responsible persons in accordance with  
2 manufacturers' instructions.
- 3 D. Submit written report that equipment or system has been properly installed and is  
4 functioning correctly.
- 5 1.28 DEMONSTRATION AND INSTRUCTIONS
- 6 A. Demonstrate operation and maintenance of Products to Owner's personnel prior to date  
7 of final inspection.
- 8 B. Demonstrate start-up, operation, control, adjustment, trouble-shooting, servicing,  
9 maintenance, and shutdown of each item of equipment at agreed-upon times, at  
10 designated location.
- 11 1.29 CONTRACT CLOSEOUT PROCEDURES
- 12 A. Submit written certification that Construction Documents have been reviewed, the Work  
13 has been inspected, and the Work is complete in accordance with Construction  
14 Documents and ready for Public Works Project Engineer's inspection.
- 15 B. Submit final Application for Payment identifying total adjusted Contract Sum / Price,  
16 previous payments, and amount remaining due.
- 17 1.30 FINAL CLEANING
- 18 A. Execute final cleaning prior to final inspection.
- 19 B. Clean interior and exterior surfaces exposed to view.
- 20 C. Remove waste and surplus materials, rubbish, and construction facilities from site.
- 21 1.31 ADJUSTING
- 22 A. Adjust operating Products and equipment to ensure smooth and unhindered operation.
- 23 1.32 OPERATION AND MAINTENANCE DATA
- 24 A. Provide operation and maintenance data for all mechanical and electrical equipment  
25 supplied and installed in project.
- 26 1.33 . SPARE PARTS AND MAINTENANCE MATERIALS
- 27 A. Provide Products, spare parts, maintenance and extra materials in quantities specified in  
28 individual Specification Sections.
- 29 B. Deliver to the Work site and place in location as directed.
- 30 1.34 AS-BUILT DRAWINGS AND SPECIFICATIONS
- 31 A. Contractor-produced Drawings and Specifications shall remain property of Contractor  
32 whether Project for which they are made is executed or not. Contractor shall furnish  
33 Public Works Project Engineer with original tracings of drawings and prints of  
34 specifications in reproducible format, one set of Drawings and Specifications and one set

1 of as-builts drawings in [AutoCAD 2007 (or lower), manually drafted] format and entire  
2 specification in Word 2000 (or lower) format on CD.  
3

4  
5 **PART 2 - RODUCTS**  
6

7 Not Used.

8 **PART 3 - EXECUTION**  
9

10 Not Used.  
11

12  
13 END OF SECTION

1 **SECTION 01 50 80 - RECYCLING**

2  
3 **PART 1 - GENERAL**

4 1.1 SUMMARY

5 A. Section Includes:

- 6  
7 1. Waste Management Goals  
8 2. Waste Management Plan  
9 3. Reuse  
10 4. Recycling  
11 5. Materials Sorting and Storage On Site  
12 6. Lists of Recycling Facilities Processors and Haulers  
13 7. Waste Management Plan Form

14 B. Related Sections:

- 15  
16 1. Section 01000 - Basic Requirements

17 1.2 WASTE MANAGEMENT GOALS

18 A. Dane County requires that as many waste materials as possible produced as result of  
19 this project be salvaged, reused or recycled in order to minimize impact of construction  
20 waste on landfills and to minimize expenditure of energy and cost in fabricating new  
21 materials. Additional information may be found in The Dane County Green Building  
22 Policy, Resolution 299, 1999-2000.

23 B. Contractor shall develop, with assistance of Public Works Project Engineer and Architect  
24 / Engineer, Waste Management Plan (WMP) for this project. Outlined in RECYCLING  
25 section of this specification are examples of materials that can be recycled or reused as  
26 well as recommendations for waste sorting methods.

27 1.3 WASTE MANAGEMENT PLAN

28 A. Contractor shall complete WMP and include cost of recycling / reuse in Bid. WMP will be  
29 submitted to Public Works Project Engineer within fifteen (15) days of Notice to Proceed  
30 date. Copy of blank WMP form is in this Section. Submittal shall include cover letter and  
31 WMP form with:

- 32 1. Information on:  
33 a. Types of waste materials produced as result of work performed on site;  
34 b. Estimated quantities of waste produced;  
35 c. Identification of materials with potential to be recycled or reused;  
36 d. How materials will be recycled or reused;  
37 e. On-site storage and separation requirements (on site containers);  
38 f. Transportation methods; and  
39 g. Destinations.

1 1.4 REUSE

2 A. Contractors and subcontractors are encouraged to reuse as many waste materials as  
3 possible. Salvage should be investigated for materials not reusable on site.

4 1.5 RECYCLING

5 A. These materials can be recycled in Dane County area:

- 6 1. Wood.
- 7 2. Wood Pallets.
- 8 3. Fluorescent Lamps.
- 9 4. Foam Insulation & Packaging (extruded and expanded).
- 10 5. PVC Plastic (pipe, siding, etc.).
- 11 6. Concrete.
- 12 7. Corrugated Cardboard.
- 13 8. Metal.
- 14 9. Carpet Padding.
- 15 10. Gypsum Drywall.
- 16 11. Barrels & Drums.
- 17 12. Solvents.

18 1.6 MATERIALS SORTING AND STORAGE ON SITE

19 A. Contractor shall provide separate containers for recyclable materials. Number of  
20 containers will be dependent upon project and site conditions.

21 B. Contractor shall provide on-site locations for subcontractors supplied recycling containers  
22 to help facilitate recycling.

23 1.7 LISTS OF RECYCLING FACILITIES PROCESSORS AND HAULERS

24 A. Web site [www.countyofdane.com](http://www.countyofdane.com) has recycling symbol (link) near top of page that lists  
25 current information for Dane County Recycling Markets. Contractors can also contact  
26 Dane County's Recycling Manager at 608/267-8815, or local city, village, town recycling  
27 staff listed in above referenced web site. Statewide listings of recycling / reuse markets at  
28 available from Wisconsin Department of Natural Resources,  
29 [www.dnr.state.wi.us/org/aw/wm/markets](http://www.dnr.state.wi.us/org/aw/wm/markets).

30  
31  
32



1 1.8 WASTE MANAGEMENT PLAN FORM

2 A. Contractor Information:

3 Name: \_\_\_\_\_

4 Address: \_\_\_\_\_

5 \_\_\_\_\_

6 Phone No.: \_\_\_\_\_ Recycling Coordinator: \_\_\_\_\_

7

MATERIAL	ESTIMATED QUANTITY	DISPOSAL METHOD (CHECK ONE)		RECYCLING / REUSE COMPANY OR DISPOSAL SITE
Salvaged & reused building materials	_____ cu. yds. _____ tons	_____ Recycled	_____ Reused	Name: _____
		_____ Landfilled	_____ Other	
Glass	_____ cu. yds. _____ tons	_____ Recycled	_____ Reused	Name: _____
		_____ Landfilled	_____ Other	
Wood	_____ cu. yds. _____ tons	_____ Recycled	_____ Reused	Name: _____
		_____ Landfilled	_____ Other	
Wood Pallets	_____ units	_____ Recycled	_____ Reused	Name: _____
		_____ Landfilled	_____ Other	
Fluorescent Lamps	_____ cu. ft. _____ lbs.	_____ Recycled	_____ Reused	Name: _____
		_____ Landfilled	_____ Other	
Foam Insulation	_____ cu. ft. _____ lbs.	_____ Recycled	_____ Reused	Name: _____
		_____ Landfilled	_____ Other	
Asphalt & Concrete	_____ cu. ft. _____ lbs.	_____ Recycled	_____ Reused	Name: _____
		_____ Landfilled	_____ Other	
PVC Plastic	_____ cu. ft. _____ lbs.	_____ Recycled	_____ Reused	Name: _____
		_____ Landfilled	_____ Other	
Corrugated Cardboard	_____ cu. ft. _____ lbs.	_____ Recycled	_____ Reused	Name: _____
		_____ Landfilled	_____ Other	
Metals	_____ cu. yds. _____ tons	_____ Recycled	_____ Reused	Name: _____
		_____ Landfilled	_____ Other	
Carpet Padding	_____ cu. ft. _____ lbs.	_____ Recycled	_____ Reused	Name: _____
		_____ Landfilled	_____ Other	
Gypsum / Drywall	_____ cu. yds. _____ tons	_____ Recycled	_____ Reused	Name: _____
		_____ Landfilled	_____ Other	
Barrels & Drums	_____ units	_____ Recycled	_____ Reused	Name: _____
		_____ Landfilled	_____ Other	

Solvents	_____ gallons	_____ Recycled _____ Landfilled	_____ Reused _____ Other	Name: _____
Other	_____	_____ Recycled _____ Landfilled	_____ Reused _____ Other	Name: _____
Other	_____	_____ Recycled _____ Landfilled	_____ Reused _____ Other	Name: _____
Other	_____	_____ Recycled _____ Landfilled	_____ Reused _____ Other	Name: _____
Other	_____	_____ Recycled _____ Landfilled	_____ Reused _____ Other	Name: _____
Other	_____	_____ Recycled _____ Landfilled	_____ Reused _____ Other	Name: _____

1

2 PART 2 PRODUCTS

3 Not Used.

4 PART 3 EXECUTION

5 Not Used.

6

END OF SECTION

1 **SECTION 06 10 00 - ROUGH CARPENTRY**

2  
3 **PART 1 - GENERAL**

4  
5 1.1 RELATED DOCUMENTS:

- 6  
7 A. Applicable provisions of Division 1 shall govern work under this Section.  
8

9 1.2 DESCRIPTION OF WORK:

- 10 A. This section includes the following.

- 11  
12  
13 1. Wood grounds, nailers and blocking.  
14 2. Sheathing.

- 15  
16 B. Related Sections:

- 17  
18 1. Architectural Woodwork is specified in another Division-6 section.  
19

20 1.3 REFERENCES:

- 21  
22 A. Lumber Standards: Comply with PS 20 and with applicable rules of the respective  
23 grading and inspecting agencies for species and products indicated.  
24

- 25 B. Plywood Product Standards: Comply with PS 1 (ANSI A 199.1) or, for products not  
26 manufactured under PS 1 provisions, with applicable APA Performance Standard for type  
27 of panel indicated.  
28

29 1.4 SUBMITTALS:

- 30  
31 A. Product Data: Submit manufacturer's specifications and installation instructions for  
32 materials listed below:  
33

- 34 1. Glass mat gypsum sheathing.  
35

- 36 B. Material Certificates: Where dimensional lumber is provided to comply with minimum  
37 allowable unit stresses, submit listing of species and grade selected for each use, and  
38 submit evidence of compliance with specified requirements. Compliance may be in form  
39 of assigned copy of applicable portion of lumber producer's grading rules showing design  
40 values for selected species and grade. Design values shall be as approved by the Board  
41 of Review of American Lumber Standards Committee.  
42

- 43 C. Wood Treatment Data: Submit treatment manufacturer's instructions for proper use of  
44 each type of treated material.  
45

- 46 1. Pressure Treatment: For each type specified, include certification by treating  
47 plant stating chemicals and process used, net amount of preservative retained  
48 and conformance with applicable standards.  
49 2. For waterborne preservatives include statement that moisture content of treated  
50 materials was reduced to a maximum of 15 percent prior to shipment to project  
51 site.  
52 3. Fire-Retardant Treatment: Include certification by treating plant that treatment

1 material complies with governing ordinances and that treatment will not bleed  
2 through finished surfaces.

3  
4 1.5 PRODUCT HANDLING:

- 5  
6 A. Delivery and Storage: Keep materials dry at all times. Protect against exposure to  
7 weather and contact with damp or wet surfaces. Stack lumber and plywood and provide  
8 air circulation within stacks.  
9

10 1.6 PROJECT CONDITIONS:

- 11  
12 A. Coordination: Fit carpentry work to other work; scribe and cope as required for accurate  
13 fit. Correlate location of furring, nailers, blocking, grounds and similar supports to allow  
14 proper attachment of other work.  
15  
16 B. Provide fire treated nailers, panels, blocking, grounds and sleepers in all locations  
17 necessary to comply with code requirements for applicable class of construction.  
18  
19

20 **PART 2 - PRODUCTS**

21  
22 2.1 MATERIALS:

23  
24 A. Lumber, General:

- 25  
26 1. Factory mark each piece of lumber with type, grade, mill and grading agency,  
27 except omit marking from surfaces to be exposed with transparent finish or  
28 without finish.  
29 2. Nominal sizes are indicated, except as shown by detail dimensions. Provide  
30 actual sizes as required by PS 20, for moisture content specified for each use.  
31  
32 a. Provide dressed lumber, S4S, unless otherwise indicated.  
33 b. Provide seasoned lumber with 19 percent maximum moisture content at  
34 time of dressing.  
35 c. Provide unseasoned lumber with moisture content in excess of 19  
36 percent allowed at time of dressing.  
37

38 B. Miscellaneous Lumber:

- 39  
40 1. Provide wood for support or attachment of other work including cant strips, buck,  
41 nailers, blocking, furring, grounds, stripping and similar members. Provide lumber  
42 of sizes shown or specified, worked into shapes shown and as follows:  
43  
44 a. Moisture content: 15 percent maximum for lumber items not specified to  
45 receive wood preservative treatment.  
46  
47 2. Grade: Construction Grade light framing size lumber of any species or board size  
48 lumber as required. Provide construction grade boards (RIS or WCLB) or No. 2  
49 boards (SPIB or WWPA).  
50

51 C. Plywood:

- 52  
53 1. Trademark: Identify each plywood panel with appropriate APA trademark.  
54 2. Plywood Backing Panels: For mounting electrical or telephone equipment, or  
55 backing in walls for architectural components, provide fire-retardant treated  
56 plywood panels with grade designation, APA C-D PLUGGED INT with exterior

1 glue, in thickness indicated or, if not otherwise indicated, not less than 1/2 inch.

2  
3 D. Glass Mat Gypsum Sheathing: Provide 1/2 inch (for 16 inches on center framing ) 5/8  
4 inch (for 24 inches on center framing) thick gypsum board complying with ASTM C 1177  
5 and the following:

- 6  
7 1. Water-repellent treated core with water absorption of less than 10 percent by  
8 weight after 2 hour immersion (ASTM C 473), and fiberglass surface on face and  
9 back.  
10 2. Sizes and Edges: 4 feet wide, not less than 8 feet long, with square edges on  
11 sides.  
12 3. "Dens-Glass Gold" by Georgia Pacific Corporation or approved equal.

13  
14 E. Miscellaneous Materials:

- 15  
16 1. Fasteners and Anchorages: Provide size, type, material and finish as indicated  
17 and as recommended by applicable standards, complying with applicable  
18 Federal Specifications for nails, staples, screws, bolts, nuts, washers and  
19 anchoring devices. Provide metal hangers and framing anchors of the size and  
20 type recommended by the manufacturer for each use including recommending  
21 nails. Where rough carpentry work is exposed to weather, in ground contact,  
22 associated with roofing work, or in areas of high relative humidity provide  
23 fasteners and anchorages with a hot-dip zinc (ASTM A 153).  
24 2. Polyethylene Vapor Barrier:  
25  
26 a. ASTM D 4397, 6 mils thick, with maximum permeance rating of 0.13  
27 perm.  
28  
29 3. Vapor-Barrier Tape:  
30  
31 a. Pressure-sensitive tape of type recommended by vapor-barrier  
32 manufacturer for sealing joints and penetrations in vapor barrier.  
33  
34 4. Weather Resistive Barriers:  
35  
36 a. Building Paper: Asphalt saturated felt, nonperforated, ASTM D 226, Type  
37 I, 15 pound type.

38  
39 2.2 WOOD TREATMENT:

40  
41 A. Preservative Treatment: Where lumber or plywood is indicated as "Trt-Wd" or "Treated"  
42 or is specified herein to be treated, comply with applicable requirements of AWPA  
43 Standards C2 (Lumber) and C9 (Plywood). Mark each treated item with the Quality Mark  
44 Requirements of and inspection agency approved by ALSC's Board of Review. Do not  
45 use chemicals containing chromium or arsenic.

- 46  
47 1. Pressure-treat above ground items with waterborne preservatives to a minimum  
48 retention of 0.25 pound/cubic foot. After treatment, kiln dry lumber and plywood  
49 to a maximum moisture content of 19 percent and 15 percent respectively. Treat  
50 indicated items and the following:  
51  
52 a. Wood cants, nailers, curbs, blocking, stripping and similar members in  
53 connection with roofing, flashing, vapor barriers and waterproofing.  
54  
55 2. Pressure-treat the following with waterborne preservatives to a minimum  
56 retention of 0.40 pound/cubic foot:

- 1  
2 a. Wood members in contact with fresh water.  
3  
4 3. Complete fabrication of treated items prior to treatment, where possible. If cut  
5 after treatment, apply field treatment complying with AWPAs M4 to cut surfaces.  
6  
7 B. Fire-Retardant Treatment: Where "FR-S" lumber or plywood is specified or otherwise  
8 indicated provide materials which comply with AWPAs standards for pressure  
9 impregnation with fire-retardant chemicals and which have a flame spread rating of not  
10 more than 25 when tested in accordance with UL Test 723 or ASTM E 84 and show no  
11 increase in flame spread and significant progressive combustion upon continuation of test  
12 for additional 20 minutes.  
13  
14 1. Where treated items are exposed on exterior or to high humidities or are to have  
15 a transparent finish in form of stain or sealer, provide materials which show no  
16 change in fire-hazard classification when subjected to standard rain test (UL 790  
17 or ASTM B 2898).  
18 2. Use fire-retardant treatment which will not bleed through or adversely affect type  
19 of finish indicated and which does not require brush treatment of field made end  
20 cuts to maintain fire-hazard classification.  
21 3. Where transparent finish is indicated use type of treatment and species which  
22 permits milling of lumber after treatment without altering indicated fire-hazard  
23 classification, as determined by fire testing.  
24 4. Kiln dry treated items to maximum moisture content of 19 percent.  
25 5. Provide UL label on each piece of fire-retardant lumber or plywood.  
26  
27 C. Inspect each piece of treated lumber or plywood after drying and discard damaged or  
28 defective pieces.  
29  
30

### 31 **PART 3 - EXECUTION**

#### 32 3.1 INSTALLATION:

- 33 A. General:
- 34  
35 1. Discard units of material with defects which might impair quality of work and units  
36 which are too small to fabricate work with minimum joints or optimum joint  
37 arrangement.  
38 2. Set carpentry work accurately to required levels and lines, with members plumb  
39 and true and accurately cut and fitted.  
40 3. Securely attach carpentry work to substrate by anchoring and fastening as  
41 shown and as required by recognized standards. Countersink nail heads on  
42 exposed carpentry work and fill holes.  
43 4. Use common wire nails, except as otherwise indicated. Use finishing nails for  
44 finish work. Select fasteners of size that will not penetrate members where  
45 opposite side will be exposed to view or will receive finish materials. Make tight  
46 connections between members. Install fasteners without splitting of wood; predrill  
47 as required.  
48  
49 B. Wood Grounds, Nailers and Blocking:
- 50  
51 1. Provide wherever shown and where required for screeding or attachment of other  
52 work. Form to shapes as shown and cut as required for true line and level of  
53 work to be attached. Coordinate location with other work involved.  
54 2. Attach to substrates as required to support applied loading. Countersink bolts  
55  
56

1 and nuts flush with surfaces, unless otherwise shown. Build into masonry during  
2 installation of masonry work. Where possible, anchor to formwork before  
3 concrete placement.

- 4 3. Provide permanent grounds of dressed, preservative treated, key-beveled lumber  
5 not less than 1-1/2 inches wide and of thickness required to bring face of ground  
6 to exact thickness of finish material involved. Remove temporary grounds when  
7 no longer required.

8  
9 K. Installation of Plywood:

- 10  
11 1. General: Comply with applicable recommendations contained in Form No. E  
12 304, "APA Design/Construction Guide - Residential & Commercial," for types of  
13 plywood products and applications indicated.  
14 2. Fastening Methods: Fasten panels as indicated below:  
15  
16 a. Plywood Backing Panels: Nail or screw to supports.

17  
18 P. Glass Mat Gypsum Wall Sheathing:

- 19  
20 1. General: Provide glass mat gypsum board sheathing where shown. Fasten to  
21 exterior face of steel stud framing for exterior walls. Use manufacturers  
22 recommended fasteners not more than 4 inches on center around perimeter and  
23 8 inches on center at intermediate supports. Keep perimeter fasteners 3/8 inch  
24 from edges and ends of board units. Fit boards tightly against each other and  
25 around openings.  
26 2. Install 2 foot x 8 foot sheathing horizontally with long edges at right angles to  
27 studs with grooved edge down. Center end joints over supports and stagger in  
28 each course. Screw to each support in accordance with manufacturer's  
29 recommended spacing, but provide not less than 4 fasteners per 2 foot width per  
30 stud if framing is diagonally braced or not less than 7 fasteners per 2 foot width  
31 per stud if not braced.  
32 3. Install 4 foot x 8 foot or longer sheathing vertically with long edges parallel to and  
33 centered over studs. Provide solid wood blocking wherever end joints do not bear  
34 against framing sills or plates. Screw to each support in accordance with  
35 manufacturer's recommended spacing, but space fasteners not more than 4  
36 inches on center around perimeter at edge and end supports and 8 inches on  
37 center at intermediate supports.  
38 4. Seal all joints in glass mat gypsum wall sheathing and trowel flat. Apply sealant  
39 over every fastener to cover completely, then trowel flat.

40  
41 Q. Miscellaneous: Lap joints of vapor barrier and weather resistive barrier in direction of  
42 water flow, lapped a minimum of 2 inches with all joints taped or sealed  
43  
44

45 END SECTION 06 10 00

1 **SECTION 07 53 00 - ELASTOMERIC MEMBRANE ROOFING**

2  
3 **PART 1 - GENERAL**

4  
5 1.1 RELATED DOCUMENTS:

- 6  
7 A. Applicable provisions of Division 1 shall govern work under this Section.  
8

9 1.2 DESCRIPTION OF WORK:

- 10  
11 A. This Section includes the following:

- 12  
13 1. Adhered sheet roofing.  
14 2. Roof insulation.  
15 3. Prefabricated pipe boots.

- 16  
17 B. Related Sections:

- 18  
19 1. Division 6 Section for "Rough Carpentry" for wood nailers, curbs, and blocking.  
20 2. Division 7 Section for "Flashing and Sheet Metal" for sheet metal flashings,  
21 counterflashings, and copings.  
22 3. Division 7 Section for "Roof Accessories" for roof hatches, prefabricated curbs  
23 and supports, expansion joint systems, plastic skylight units.  
24

25 1.3 PERFORMANCE REQUIREMENTS:

- 26  
27 A. General: Install sheet membrane roofing and base flashing that are watertight; will not  
28 permit the passage of liquid water, and will withstand wind loads, thermally induced  
29 movement, and exposure to weather without failure.  
30  
31 B. Material Compatibility: Provide roofing materials that are compatible with one another  
32 under conditions of service and application required, as demonstrated by roofing system  
33 manufacturer based on testing and field experience.  
34  
35 C. FM Listing: Provide sheet membrane, base flashings, and component materials that  
36 meet requirements of FM 4450 and FM 4470 as part of a roofing system and that are  
37 listed in FM's "Approval Guide" for Class 1 or noncombustible construction, as applicable.  
38 Identify materials with FM markings.  
39  
40 1. The roofing system shall comply with the following:  
41  
42 a. Fire/Windstorm Classification: Class 1A-90.  
43 b. Hail Resistance: MH.  
44  
45 D. Roofing System Design: Provide a roofing system that complies with roofing system  
46 manufacturer's written design instructions and with the following:  
47  
48 1. SPRI's "Written Design Guide for Adhered Roofing Systems."  
49

50 1.4 SUBMITTALS:

- 51  
52 A. Product Data: Submit product data for each type of roofing product specified. Include



1 data substantiating that materials comply with requirements.  
2

3 B. Shop Drawings: Submit plans, sections and details for the following:  
4

- 5 1. Base flashings (at wall/parapets, curbs, supports) and membrane terminations  
6 (at copings, termination bars, counterflashings.).
- 7 2. Pipe flashings and pitch pockets.
- 8 3. Taper insulation layouts, including slopes.  
9

10 C. Submit manufacturer's instructions for surface preparation, elastic flashing, joint cover  
11 sheet and joint and crack sealants with temperature range for application.  
12

13 D. Samples:  
14

- 15 1. Submit samples of roof pavers.
- 16 2. Submit 3-lb. samples of aggregate surfacing material (rock ballast)  
17

18 1.5 QUALITY ASSURANCE:  
19

20 A. Manufacturer: Obtain primary elastomeric sheet roofing from a single manufacturer, to  
21 greatest extent possible. Provide secondary materials only as recommended by  
22 manufacturer or primary materials.  
23

24 B. Installer:  
25

- 26 1. A firm with not less than 3 years of successful experience in installation of roofing  
27 systems similar to those required for this project and which is acceptable to or  
28 licensed by manufacturer of primary roofing materials.
- 29 2. As applicable, assign work closely associated with elastomeric sheet roofing,  
30 including (but not limited to) vapor barriers, insulation, flashing and  
31 counterflashing, expansion joints, and joint sealers, to installer of flexible sheet  
32 roofing.  
33

34 C. Pre-roofing Conference: Prior to installation of roofing and associated work, meet at  
35 project site with Installer, roofing manufacturer, installers of related work, and other  
36 entities concerned with roofing performance, including (where applicable) Owner's  
37 insurer, test agencies, governing authorities, Architect, and Owner. Record discussions  
38 and agreements and furnish copy to each participant.  
39

- 40 1. Review methods and procedures related to roofing installation, including  
41 manufacturer's written instructions.
- 42 2. Examine deck substrate conditions and finishes for compliance with  
43 requirements, including flatness and fastening.
- 44 3. Review loading limitations of deck during and after roofing.
- 45 4. Review flashings, special roofing details, roof drainage, roof penetrations,  
46 equipment curbs, and condition of other construction that will affect roofing.
- 47 5. Review temporary protection requirements for roofing system during and after  
48 installations.  
49

50 D. Insurance Certification: Assist Owner in preparation and submittal of whatever roof  
51 installation acceptance certification may be necessary in connection with fire and  
52 extended coverage insurance on roofing and associated work.  
53

54 1.6 DELIVERY, STORAGE, AND HANDLING:  
55

56 A. Deliver roofing materials to Project site in original containers with seals unbroken and

1 labeled with manufacturer's name, product brand name and type, date of manufacture,  
2 and directions for storing and mixing with other components.

- 3  
4 B. Store liquid materials in their original undamaged containers in a clean, dry, protected  
5 location and within the temperature range required by roofing system manufacturer.  
6 Protect stored liquid materials from direct sunlight. Discard and legally dispose of liquid  
7 material that cannot be applied within its stated shelf life.  
8  
9 C. Protect roof insulation materials from physical damage and from deterioration by sunlight,  
10 moisture, soiling, and other sources. Store in a dry location. Comply with insulation  
11 manufacturer's written instructions for handling, storing, and protecting during installation.  
12  
13 D. Handle and store roofing materials and place equipment in a manner to avoid permanent  
14 deflection of deck.

15  
16 1.7 PROJECT CONDITIONS:

- 17  
18 A. Weather Limitations: Proceed with roofing work only when existing and forecasted  
19 weather conditions permit roofing to be installed according to manufacturer's written  
20 instructions and warranty requirements.  
21

22 1.8 WARRANTY:

- 23  
24 A. Provide written warranty, signed by contractor, installer and manufacturer of primary  
25 roofing materials, agreeing to replace/repair defective materials and workmanship,  
26 including significant leakage of water, abnormal aging or deterioration of materials, and  
27 other failures of sheet roofing to perform as required within warranty period. Repairs and  
28 replacements required because of acts of Nature and other events beyond  
29 Contractors/Installers/Manufacturer's control (and which exceed performance  
30 requirements) shall be completed by Contractor/Installer and paid for by Owner at  
31 prevailing rates.

- 32  
33 1. Warranty period is 20 years after date of substantial completion.  
34  
35

36 **PART 2 - PRODUCTS**

37  
38 2.1 EPDM MANUFACTURERS:

- 39 A. Subject to compliance with requirements, provide one of the following:

40 Sure Seal; Carlisle Syntec Systems  
41 Rubbergard; Firestone Building Products  
42 Versigard; Versico, Inc.  
43 Celo-1; Celotex Corporation  
44 SPM; John-Manville  
45  
46  
47

48 2.2 ELASTOMERIC SHEET MATERIALS:

- 49  
50 A. EPDM Sheet: Uniform, flexible sheet formed from a terpolymer of ethylene-propylene-  
51 diene, complying with ASTM D 4637, Type 1, of the following grade, class, thickness,  
52 backing, and exposed face color:

- 53  
54 1. Grade and class: Grade 1 and Class U, unreinforced.  
55 2. Thickness: 60 mils, nominal.  
56 3. Backing: Unbacked.

1  
2  
3  
4  
5  
6  
7  
8  
9  
10  
11  
12  
13  
14  
15  
16  
17  
18  
19  
20  
21  
22  
23  
24  
25  
26  
27  
28  
29  
30  
31  
32  
33  
34  
35  
36  
37  
38  
39  
40  
41  
42  
43  
44  
45  
46  
47  
48  
49  
50  
51  
52  
53  
54  
55  
56

4. Exposed Face Color: Black.

B. Sheet Flashing: Manufacturer's standard system, 60 mils thick EPDM, uncured or cured, according to application.

2.3 AUXILIARY MATERIALS:

A. Sheet Seaming System: Manufacturer's standard materials for sealing lapped joints, including edge sealer to cover exposed spliced edges as recommended by manufacturer.

B. Flashing Accessories: Types recommended by manufacturer of membrane material provided at locations indicated and at locations recommended by manufacturer and including adhesive tapes, flashing cements and sealants.

C. Bonding Adhesive: Manufacturer's standard bonding adhesive for adhered membrane systems.

D. Liquid Coating: Use for adhered membrane systems. Coating shall be specifically formulated for coating EPDM sheet roofing; acrylic emulsion base, in color to be selected from manufacturer's full range of colors by the Architect.

E. Miscellaneous Accessories: Provide pourable sealers, preformed cone pipe flashings, and other accessories recommended by roofing system manufacturer for intended use.

2.4 INSULATING MATERIALS:

A. General: Provide insulating materials to comply with requirements indicated for materials and compliance with referenced standards in sizes to fit applications indicated, selected from manufacturer's standard thicknesses, widths and lengths.

B. Polyisocyanurate Board (Fill) Insulation: Rigid, cellular polyisocyanurate thermal insulation with core formed by using HCFCs as blowing agents to comply with ASTM C 1289, with Type II, glass-fiber mat facers both major surfaces. Aged R value of 7.2 minimum per inch of thickness.

- 1. Provide boards with parallel faces.
- 2. Provide standard tapered boards for crickets and sloped features.

2.5 INSULATION ACCESSORIES:

A. General: Furnish roof insulation accessories recommended by insulation manufacturer for intended use and compatible with membrane roofing.

B. Fasteners: Factory-coated steel fasteners and metal or plastic plates meeting corrosion-resistance provisions in FMG 4470, designed for fastening roof insulation to substrate, and acceptable to roofing system manufacturer.

C. Cold Fluid-Applied Adhesive: Manufacturer's standard cold fluid-applied adhesive formulated to adhere roof insulation to substrate.

D. Cover Board: ASTM C 1177/C 1177M, glass-mat, water-resistant gypsum substrate, 1/4 inch thick.

- 1. Product: Subject to compliance with requirements, provided "Dens-Deck" manufactured by Georgia-Pacific Corporation.

- 1 E. Metal Securement System: Perimeter securement flashing and strapping fabricated from  
2 stainless steel, a minimum of 0.031 inch thick. Provide fasteners as recommended by  
3 mortar-faced insulation manufacturer.  
4  
5

### 6 **PART 3 - EXECUTION**

#### 7 8 3.1 EXAMINATION

- 9  
10 A. Examine substrates, areas, and conditions, with Installer present, for compliance with the  
11 following requirements and other conditions affecting performance of roofing system:  
12  
13 1. Verify that roof openings and penetrations are in place and set and braced and  
14 that roof drains are securely clamped in place.  
15 2. Verify that wood blocking, curbs, and nailers are securely anchored to roof deck  
16 at penetrations and terminations and that nailers match thicknesses of insulation.  
17 3. Proceed with installation only after unsatisfactory conditions have been  
18 corrected.  
19

#### 20 3.2 PREPARATION

- 21  
22 A. Clean substrate of dust, debris, moisture, and other substances detrimental to roofing  
23 installation according to roofing system manufacturer's written instructions. Remove  
24 sharp projections.  
25  
26 B. Prevent materials from entering and clogging roof drains and conductors and from spilling  
27 or migrating onto surfaces of other construction. Remove roof-drain plugs when no work  
28 is taking place or when rain is forecast.  
29  
30 C. Complete terminations and base flashings and provide temporary seals to prevent water  
31 from entering completed sections of roofing system at the end of the workday or when  
32 rain is forecast. Remove and discard temporary seals before beginning work on  
33 adjoining roofing.  
34

#### 35 3.3 INSULATION INSTALLATION

- 36  
37 A. Coordinate installing membrane roofing system components so insulation is not exposed  
38 to precipitation or left exposed at the end of the workday.  
39  
40 B. Comply with membrane roofing system manufacturer's written instructions for installing  
41 roof insulation.  
42  
43 C. Install parallel face or tapered insulation under area of roofing to conform to slopes  
44 indicated.  
45  
46 D. Install one or more layers of insulation under area of roofing to achieve required  
47 thickness. Where overall insulation thickness is 2 inches or greater, install 2 or more  
48 layers with joints of each succeeding layer staggered from joints of previous layer a  
49 minimum of 6 inches in each direction.  
50  
51 E. Trim surface of insulation where necessary at roof drains so completed surface is flush  
52 and does not restrict flow of water.  
53  
54 F. Install insulation with long joints of insulation in a continuous straight line with end joints  
55 staggered between rows, abutting edges and ends between boards. Fill gaps exceeding  
56 1/4 inch with insulation.

1  
2  
3  
4  
5  
6  
7  
8  
9  
10  
11  
12  
13  
14  
15  
16  
17  
18  
19  
20  
21  
22  
23  
24  
25  
26  
27  
28  
29  
30  
31  
32  
33  
34  
35  
36  
37  
38  
39  
40  
41  
42  
43  
44  
45  
46  
47  
48  
49  
50  
51  
52  
53  
54  
55

- 1. Cut and fit insulation within 1/4 inch of nailers, projections, and penetrations.
- G. Mechanically Fastened and Adhered Insulation: Install each layer of insulation and secure first layer of insulation to deck using mechanical fasteners specifically designed and sized for fastening specified board-type roof insulation to deck type.
  - 1. Fasten first layer of insulation according to requirements in FMG's "Approval Guide" for specified Windstorm Resistance Classification.
  - 2. Fasten first layer of insulation to resist uplift pressure at corners, perimeter, and field of roof.
  - 3. Install subsequent layers of insulation in a cold fluid-applied adhesive.
- H. Install cover boards over insulation with long joints in continuous straight lines with end joints staggered between rows. Loosely butt cover boards together and fasten to roof deck.
  - 1. Fasten insulation according to requirements in FMG's "Approval Guide" for specified Windstorm Resistance Classification.
  - 2. Fasten insulation to resist uplift pressure at corners, perimeter, and field of roof.

3.4 ADHERED ROOFING MEMBRANE INSTALLATION

- A. Install roofing membrane over area to receive roofing according to membrane roofing system manufacturer's written instructions. Unroll roofing membrane and allow to relax before installing.
- B. Start installation of roofing membrane in presence of membrane roofing system manufacturer's technical personnel.
- C. Accurately align roofing membrane and maintain uniform side and end laps of minimum dimensions required by manufacturer. Stagger end laps.
- D. Bonding Adhesive: Apply bonding adhesive to substrate and underside of roofing membrane at rate required by manufacturer and allow to partially dry before installing roofing membrane. Do not apply bonding adhesive to splice area of roofing membrane.
- E. Cold Fluid-Applied Adhesive: Apply cold fluid-applied adhesive to substrate at rate required by manufacturer and install fleece-backed roofing membrane.
- F. Mechanically or adhesively fasten roofing membrane securely at terminations, penetrations, and perimeter of roofing.
- G. Apply roofing membrane with side laps shingled with slope of roof deck where possible.
- H. Adhesive Seam Installation: Clean both faces of splice areas, apply splicing cement, and firmly roll side and end laps of overlapping roofing membranes according to manufacturer's written instructions to ensure a watertight seam installation. Apply lap sealant and seal exposed edges of roofing membrane terminations.
  - 1. Apply a continuous bead of in-seam sealant before closing splice if required by membrane roofing system manufacturer.
- I. Tape Seam Installation: Clean and prime both faces of splice areas, apply splice tape, and firmly roll side and end laps of overlapping roofing membranes according to

1 manufacturer's written instructions to ensure a watertight seam installation. Apply lap  
2 sealant and seal exposed edges of roofing membrane terminations.

- 3
- 4 J. Repair tears, voids, and lapped seams in roofing that does not meet requirements.
- 5
- 6 K. Spread sealant or mastic bed over deck drain flange at deck drains and securely seal  
7 roofing membrane in place with clamping ring.
- 8
- 9 L. Install roofing membrane and auxiliary materials to tie in to existing roofing.
- 10
- 11 M. Apply epichlorohydrin sheet over roofing membrane at locations indicated.
- 12

### 13 3.5 BASE FLASHING INSTALLATION

- 14
- 15 A. Install sheet flashings and preformed flashing accessories and adhere to substrates  
16 according to membrane roofing system manufacturer's written instructions.
- 17
- 18 B. Apply bonding adhesive to substrate and underside of sheet flashing at required rate and  
19 allow to partially dry. Do not apply bonding adhesive to seam area of flashing.
- 20
- 21 C. Flash penetrations and field-formed inside and outside corners with cured or uncured  
22 sheet flashing.
- 23
- 24 D. Clean splice areas, apply splicing cement, and firmly roll side and end laps of overlapping  
25 sheets to ensure a watertight seam installation. Apply lap sealant and seal exposed  
26 edges of sheet flashing terminations.
- 27
- 28 E. Terminate and seal top of sheet flashings.
- 29

### 30 3.6 FIELD QUALITY CONTROL

- 31
- 32 A. Final Roof Inspection: Arrange for roofing system manufacturer's technical personnel to  
33 inspect roofing installation on completion and submit report to Architect.
- 34
- 35 1. Notify Architect or Owner 48 hours in advance of date and time of inspection.
- 36
- 37 B. Repair or remove and replace components of membrane roofing system where test  
38 results or inspections indicate that they do not comply with specified requirements.
- 39
- 40 C. Additional testing and inspecting, at Contractor's expense, will be performed to determine  
41 compliance of replaced or additional work with specified requirements.
- 42

### 43 3.7 PROTECTING AND CLEANING

- 44
- 45 A. Protect membrane roofing system from damage and wear during remainder of  
46 construction period. When remaining construction will not affect or endanger roofing,  
47 inspect roofing for deterioration and damage, describing its nature and extent in a written  
48 report, with copies to Architect and Owner.
- 49
- 50 B. Correct deficiencies in or remove membrane roofing system that does not comply with  
51 requirements, repair substrates and repair or reinstall membrane roofing system to a  
52 condition free of damage and deterioration at time of Substantial Completion and  
53 according to warranty requirements.
- 54
- 55 C. Clean overspray and spillage from adjacent construction using cleaning agents and  
56 procedures recommended by manufacturer of affected construction.

1  
2  
3 END SECTION 07 53 00

**SECTION 07 54 00 - THERMOPLASTIC MEMBRANE ROOFING - Alternate No. 1**

**PART 1 - GENERAL**

1.1 RELATED DOCUMENTS

- A. Applicable provisions of the Agreement and Division 1 shall govern work of this section.

1.2 SUMMARY

- A. This Section includes the following:

1. Adhered membrane roofing system.
2. Roof insulation.

- B. Related Sections include the following:

1. Division 6 Section "Rough Carpentry" for wood nailers, curbs, and blocking.
2. Division 7 Section "Sheet Metal Flashing and Trim" for metal roof penetration flashings, flashings, and counterflashings.
3. Division 7 Section "Roof Accessories."

1.2 DEFINITIONS

- A. Roofing Terminology: Refer to ASTM D 1079 and glossary of NRCA's "The NRCA Roofing and Waterproofing Manual" for definition of terms related to roofing work in this Section.
- B. Design Uplift Pressure: The uplift pressure, calculated according to procedures in SPRI's "Wind Load Design Guide for Fully Adhered and Mechanically Fastened Roofing Systems," before multiplication by a safety factor.
- C. Factored Design Uplift Pressure: The uplift pressure, calculated according to procedures in SPRI's "Wind Load Design Guide for Fully Adhered and Mechanically Fastened Roofing Systems," after multiplication by a safety factor.

1.3 PERFORMANCE REQUIREMENTS

- A. General: Provide installed roofing membrane and base flashings that remain watertight; do not permit the passage of water; and resist specified uplift pressures, thermally induced movement, and exposure to weather without failure.
- B. Material Compatibility: Provide roofing materials that are compatible with one another under conditions of service and application required, as demonstrated by roofing membrane manufacturer based on testing and field experience.
- C. FMG Listing: Provide roofing membrane, base flashings, and component materials that comply with requirements in FMG 4450 and FMG 4470 as part of a membrane roofing system and that are listed in FMG's "Approval Guide" for Class 1 or noncombustible construction, as applicable. Identify materials with FMG markings.



1. Fire/Windstorm Classification: Class 1A-90.
2. Hail Resistance: MH.

#### 1.4 SUBMITTALS

- A. Product Data: For each type of product indicated.
- B. Shop Drawings: For roofing system. Include plans, elevations, sections, details, and attachments to other Work.
  1. Base flashings and membrane terminations.
  2. Insulation fastening patterns.
- C. Samples for Verification: For the following products:
  1. 12-by-12-inch square of sheet roofing, of color specified, including T-shaped side and end lap seam.
  2. 12-by-12-inch square of roof insulation.
- D. Installer Certificates: Signed by roofing system manufacturer certifying that Installer is approved, authorized, or licensed by manufacturer to install roofing system.
- E. Manufacturer Certificates: Signed by roofing manufacturer certifying that roofing system complies with requirements specified in "Performance Requirements" Article.
  1. Submit evidence of meeting performance requirements.
- F. Qualification Data: For Installer and manufacturer.
- G. Product Test Reports: Based on evaluation of comprehensive tests performed by manufacturer and witnessed by a qualified testing agency, for components of roofing system.
- H. Research/Evaluation Reports: For components of membrane roofing system.
- I. Maintenance Data: For roofing system to include in maintenance manuals.
- J. Warranties: Special warranties specified in this Section.
- K. Inspection Report: Copy of roofing system manufacturer's inspection report of completed roofing installation.

#### 1.5 QUALITY ASSURANCE

- A. Installer Qualifications: A qualified firm that is approved, authorized, or licensed by roofing system manufacturer to install manufacturer's product and that is eligible to receive manufacturer's warranty.
- B. Manufacturer Qualifications: A qualified manufacturer that has FMG approval for membrane roofing system identical to that used for this Project.
- C. Fire-Test-Response Characteristics: Provide membrane roofing materials with the fire-test-response characteristics indicated as determined by testing identical products per test method below by UL, FMG, or another testing and inspecting agency acceptable to authorities having jurisdiction. Materials shall be identified with appropriate markings of applicable testing and inspecting agency.

1  
2  
3  
4  
5  
6  
7  
8  
9  
10  
11  
12  
13  
14  
15  
16  
17  
18  
19  
20  
21  
22  
23  
24  
25  
26  
27  
28  
29  
30  
31  
32  
33  
34  
35  
36  
37  
38  
39  
40  
41  
42  
43  
44  
45  
46  
47  
48  
49  
50  
51  
52  
53  
54

1. Exterior Fire-Test Exposure: Class A ASTM E 108, for application and roof slopes indicated.
  2. Fire-Resistance Ratings: ASTM E 119, for fire-resistance-rated roof assemblies of which roofing system is a part.
- D. Preinstallation Conference: Conduct conference at Project site. Comply with requirements in Division 1 Section "Project Management and Coordination." Review methods and procedures related to roofing system including, but not limited to, the following:
1. Meet with roofing Installer, roofing system manufacturer's representative, deck Installer, and installers whose work interfaces with or affects roofing including installers of roof accessories and roof-mounted equipment.
  2. Review methods and procedures related to roofing installation, including manufacturer's written instructions.
  3. Review and finalize construction schedule and verify availability of materials, Installer's personnel, equipment, and facilities needed to make progress and avoid delays.
  4. Examine deck substrate conditions and finishes for compliance with requirements, including flatness and fastening.
  5. Review structural loading limitations of roof deck during and after roofing.
  6. Review base flashings, special roofing details, roof drainage, roof penetrations, equipment curbs, and condition of other construction that will affect roofing system.
  7. Review governing regulations and requirements for insurance and certificates if applicable.
  8. Review temporary protection requirements for roofing system during and after installation.
  9. Review roof observation and repair procedures after roofing installation.

1.6 DELIVERY, STORAGE, AND HANDLING

- A. Deliver roofing materials to Project site in original containers with seals unbroken and labeled with manufacturer's name, product brand name and type, date of manufacture, and directions for storing and mixing with other components.
- B. Store liquid materials in their original undamaged containers in a clean, dry, protected location and within the temperature range required by roofing system manufacturer. Protect stored liquid material from direct sunlight.
  1. Discard and legally dispose of liquid material that cannot be applied within its stated shelf life.
- C. Protect roof insulation materials from physical damage and from deterioration by sunlight, moisture, soiling, and other sources. Store in a dry location. Comply with insulation manufacturer's written instructions for handling, storing, and protecting during installation.
- D. Handle and store roofing materials and place equipment in a manner to avoid permanent deflection of deck.

1.7 PROJECT CONDITIONS

- 1 A. Weather Limitations: Proceed with installation only when existing and forecasted  
2 weather conditions permit roofing system to be installed according to manufacturer's  
3 written instructions and warranty requirements.  
4

5 1.8 WARRANTY  
6

- 7 A. Special Warranty: Manufacturer's standard form, without monetary limitation, in which  
8 manufacturer agrees to repair or replace components of membrane roofing system that  
9 fail in materials or workmanship within specified warranty period. Failure includes roof  
10 leaks.  
11  
12 1. Special warranty includes roofing membrane, base flashings, roofing membrane  
13 accessories, roof insulation fasteners, vapor retarder and other components of  
14 membrane roofing system.  
15 2. Warranty Period: 20 years from date of Substantial Completion.  
16  
17

18 **PART 2 - PRODUCTS**  
19

20 2.1 THERMOPLASTIC POLYOLEFIN ROOFING MEMBRANE  
21

- 22 A. Fabric-Reinforced Thermoplastic Polyolefin Sheet: ASTM D 6878, internally fabric or scrim  
23 reinforced, uniform, flexible TPO sheet.  
24  
25 1. Manufacturers: Subject to compliance with requirements, provide products by one of the  
26 following:  
27  
28 a. Carlisle SynTec Incorporated.  
29 b. Custom Seal Roofing.  
30 c. Firestone Building Products Company.  
31 d. GAF Materials Corporation.  
32 e. GenFlex Roofing Systems.  
33 f. Johns Manville.  
34 g. Mule-Hide Products Co., Inc.  
35 h. Stevens Roofing Systems; Division of JPS Elastomerics.  
36 i. Versico Incorporated.  
37  
38 2. Physical Properties:  
39  
40 a. Thickness: 60 mils thickness, nominal.  
41 b. Exposed Face Color: White.  
42 c. Physical Properties:  
43 d. Breaking Strength: 225 lbf; ASTM D 751, grab method.  
44 e. Elongation at Break: 15 percent; ASTM D 751.  
45 f. Tearing Strength: 55 lbf minimum; ASTM D 751, Procedure B.  
46 g. Brittleness Point: Minus 22 deg F.  
47 h. Ozone Resistance: No cracks after sample, wrapped around a 3-inch- diameter  
48 mandrel, is exposed for 166 hours to a temperature of 104 deg F and an ozone  
49 level of 100 pphm; ASTM D 1149.  
50

51 2.2 AUXILIARY MATERIALS  
52

- 53 A. General: Auxiliary materials recommended by roofing system manufacturer for intended  
54 use and compatible with membrane roofing.  
55

1  
2  
3  
4  
5  
6  
7  
8  
9  
10  
11  
12  
13  
14  
15  
16  
17  
18  
19  
20  
21  
22  
23  
24  
25  
26  
27  
28  
29  
30  
31  
32  
33  
34  
35  
36  
37  
38  
39  
40  
41  
42  
43  
44  
45  
46  
47  
48  
49  
50  
51  
52  
53  
54  
55  
56

- 1. Liquid-type auxiliary materials shall meet VOC limits of authorities having jurisdiction.
- B. Sheet Flashing: Manufacturer's standard unreinforced thermoplastic polyolefin sheet flashing, 55 mils thick, minimum, of same color as sheet membrane.
- C. Bonding Adhesive: Manufacturer's standard water-based bonding adhesive for membrane, and solvent-based bonding adhesive for base flashings.
- D. Slip Sheet: Manufacturer's recommended slip sheet, of type required for application.
- E. Metal Termination Bars: Manufacturer's standard predrilled stainless-steel or aluminum bars, approximately 1 by 1/8 inch thick; with anchors.
- F. Metal Battens: Manufacturer's standard aluminum-zinc-alloy-coated or zinc-coated steel sheet, approximately 1 inch wide by 0.05 inch thick, prepunched.
- G. Fasteners: Factory-coated steel fasteners and metal or plastic plates meeting corrosion-resistance provisions in FMG 4470, designed for fastening membrane to substrate, and acceptable to membrane roofing system manufacturer.
- H. Miscellaneous Accessories: Provide pourable sealers, preformed cone and vent sheet flashings, preformed inside and outside corner sheet flashings, T-joint covers, termination reglets, cover strips, and other accessories.

2.3 ROOF INSULATION

- A. General: Preformed roof insulation boards manufactured or approved by TPO membrane roofing manufacturer, selected from manufacturer's standard sizes suitable for application, of thicknesses indicated.
- B. Polyisocyanurate Board (Fill) Insulation: Rigid, cellular polyisocyanurate thermal insulation with core formed by using HCFCs as blowing agents to comply with ASTM C 1289, with Type II, glass-fiber mat facers both major surfaces. Aged R value of 7.2 minimum per inch of thickness.
  - 1. Provide boards with parallel faces.
  - 2. Provide standard tapered boards for crickets and sloped features.

2.4 INSULATION ACCESSORIES

- A. General: Furnish roof insulation accessories recommended by insulation manufacturer for intended use and compatible with membrane roofing.
- B. Fasteners: Factory-coated steel fasteners and metal or plastic plates meeting corrosion-resistance provisions in FMG 4470, designed for fastening roof insulation to substrate, and acceptable to roofing system manufacturer.
- C. Cold Fluid-Applied Adhesive: Manufacturer's standard cold fluid-applied adhesive formulated to adhere roof insulation to substrate.
- D. Cover Board: ASTM C 1177/C 1177M, glass-mat, water-resistant gypsum substrate, 1/4 inch thick.
  - 1. Product: Subject to compliance with requirements, provided "Dens-Deck" manufactured by Georgia-Pacific Corporation.

1  
2  
3 **PART 3 - EXECUTION**  
4

5 3.1 EXAMINATION  
6

- 7 A. Examine substrates, areas, and conditions, with Installer present, for compliance with the  
8 following requirements and other conditions affecting performance of roofing system:  
9
- 10 1. Verify that roof openings and penetrations are in place and set and braced and  
11 that roof drains are securely clamped in place.
  - 12 2. Verify that wood blocking, curbs, and nailers are securely anchored to roof deck  
13 at penetrations and terminations and that nailers match thicknesses of insulation.
  - 14 3. Verify that surface plane flatness and fastening of steel roof deck comply with  
15 requirements in Division 5 Section "Steel Deck."
  - 16 4. Proceed with installation only after unsatisfactory conditions have been  
17 corrected.

18  
19 3.2 PREPARATION  
20

- 21 A. Clean substrate of dust, debris, moisture, and other substances detrimental to roofing  
22 installation according to roofing system manufacturer's written instructions. Remove  
23 sharp projections.  
24
- 25 B. Complete terminations and base flashings and provide temporary seals to prevent water  
26 from entering completed sections of roofing system at the end of the workday or when  
27 rain is forecast. Remove and discard temporary seals before beginning work on  
28 adjoining roofing.  
29

30 3.3 INSULATION INSTALLATION  
31

- 32 A. Coordinate installing membrane roofing system components so insulation is not exposed  
33 to precipitation or left exposed at the end of the workday.  
34
- 35 B. Comply with membrane roofing system manufacturer's written instructions for installing  
36 roof insulation.  
37
- 38 C. Install parallel face or tapered insulation under area of roofing to conform to slopes indi-  
39 cated.  
40
- 41 D. Install one or more layers of insulation under area of roofing to achieve required thick-  
42 ness. Where overall insulation thickness is 2 inches or greater, install 2 or more layers  
43 with joints of each succeeding layer staggered from joints of previous layer a minimum of  
44 6 inches in each direction.  
45
- 46 E. Trim surface of insulation where necessary at roof drains so completed surface is flush  
47 and does not restrict flow of water.  
48
- 49 F. Install insulation with long joints of insulation in a continuous straight line with end joints  
50 staggered between rows, abutting edges and ends between boards. Fill gaps exceeding  
51 1/4 inch with insulation.  
52
- 53 1. Cut and fit insulation within 1/4 inch of nailers, projections, and penetrations.  
54
- 55 H. Adhered Insulation: Install each layer of insulation and adhere to substrate as follows:  
56

1. Prime surface of concrete deck with asphalt primer at a rate of 3/4 gallon/100 square feet and allow primer to dry.
2. Set each layer of insulation in a cold fluid-applied adhesive.

### 3.4 ADHERED ROOFING MEMBRANE INSTALLATION

- A. Install roofing membrane over area to receive roofing according to membrane roofing system manufacturer's written instructions. Unroll roofing membrane and allow to relax before installing.
  1. Install sheet according to ASTM D 5036.
- B. Start installation of roofing membrane in presence of membrane roofing system manufacturer's technical personnel.
- C. Accurately align roofing membrane and maintain uniform side and end laps of minimum dimensions required by manufacturer. Stagger end laps.
- D. Bonding Adhesive: Apply water-based bonding adhesive to substrate at rate required by manufacturer and immediately install roofing membrane. Do not apply bonding adhesive to splice area of roofing membrane.
- E. Adhesively fasten roofing membrane securely at terminations, penetrations, and perimeter of roofing.
- F. Apply roofing membrane with side laps shingled with slope of roof deck where possible.
- G. Seams: Clean seam areas, overlap roofing membrane, and hot-air weld side and end laps of roofing membrane according to manufacturer's written instructions to ensure a watertight seam installation.
  1. Test lap edges with probe to verify seam weld continuity. Apply lap sealant to seal cut edges of roofing membrane.
  2. Verify field strength of seams a minimum of twice daily and repair seam sample areas.
  3. Repair tears, voids, and lapped seams in roofing membrane that does not meet requirements.

### 3.5 BASE FLASHING INSTALLATION

- a. Install sheet flashings and preformed flashing accessories and adhere to substrates according to membrane roofing system manufacturer's written instructions.
- b. Apply water-based bonding adhesive to substrate and underside of sheet flashing at required rate and allow to partially dry. Do not apply bonding adhesive to seam area of flashing.
- c. Flash penetrations and field-formed inside and outside corners with sheet flashing.
- d. Clean seam areas and overlap and firmly roll sheet flashings into the adhesive. Weld side and end laps to ensure a watertight seam installation.
- e. Terminate and seal top of sheet flashings and mechanically anchor to substrate through termination bars.

### 3.7 PROTECTING AND CLEANING

1  
2  
3  
4  
5  
6  
7  
8  
9  
10  
11  
12  
13  
14  
15  
16

- A. Protect membrane roofing system from damage and wear during remainder of construction period. When remaining construction will not affect or endanger roofing, inspect roofing for deterioration and damage, describing its nature and extent in a written report, with copies to Architect and Owner.
- B. Correct deficiencies in or remove membrane roofing system that does not comply with requirements, repair substrates, and repair or reinstall membrane roofing system to a condition free of damage and deterioration at time of Substantial Completion and according to warranty requirements.
- C. Clean overspray and spillage from adjacent construction using cleaning agents and procedures recommended by manufacturer of affected construction.

END OF SECTION 07 54 00

1  
2 **SECTION 07 62 00 - FLASHING AND SHEET METAL**

3  
4 **PART 1 - GENERAL**

5  
6 1.1 RELATED DOCUMENTS:

- 7  
8 A. Applicable provisions of Division 1 shall govern work under this Section.  
9

10 1.2 DESCRIPTION OF WORK:

- 11 A. This section includes the following:

- 12  
13  
14 1. Metal counter flashing; and base flashing.  
15 2. Metal copings.  
16 3. Radius metal coping  
17 4. Metal expansion joints.  
18 5. Built-in metal scuppers, downspouts and conductor heads.  
19 6. Miscellaneous sheet metal accessories.  
20

- 21 B. Related sections:

- 22  
23 1. Roofing accessories (excluding roof accessories) are specified in roofing system  
24 sections as roofing work.  
25

26 1.3 SUBMITTALS:

- 27  
28 A. Product Data; Flashing, Sheet Metal, Accessories: Submit manufacturer's product  
29 specifications, installation instructions and general recommendations for each specified  
30 sheet material and fabricated product.  
31

- 32 B. Samples; Flashing, Sheet Metal, Accessories:

- 33  
34 1. Submit 2, 8 inch square samples of specified sheet materials to be exposed as  
35 finished surfaces.  
36

- 37 C. Shop Drawings; Flashing, Sheet Metal, Accessories: Submit shop drawings showing  
38 layout, joining, profiles, and anchorages of fabricated work, including major counter  
39 flashings, trim/fascia units, gutters, downspouts, scuppers and expansion joint systems;  
40 layouts at 1/4 inch scale, details at 3 inch scale.  
41

42 1.4 JOB CONDITIONS:

- 43  
44 A. Coordinate work of this section with interfacing and adjoining work for proper sequencing  
45 of each installation. Ensure best possible weather resistance and durability of the work  
46 and protection of materials and finishes.  
47  
48

49 **PART 2 - PRODUCTS**

50  
51 2.1 FLASHING AND SHEET METAL MATERIALS:

- 52  
53 A. Sheet Metal Flashing/Trim:



1  
2  
3  
4  
5  
6  
7  
8  
9  
10  
11  
12  
13  
14  
15  
16  
17  
18  
19  
20  
21  
22  
23  
24  
25  
26  
27  
28  
29  
30  
31  
32  
33  
34  
35  
36  
37  
38  
39  
40  
41  
42  
43  
44  
45  
46  
47  
48  
49  
50  
51  
52  
53  
54  
55  
56  
57

1. Paint coated sheet steel: Shop formed, 0.028 inches thick prior to painting, hot-dipped galvanized steel, commercial quality AISI G90 extra smooth. Primed and finished on one side with Duranar 200 fluoropolymer coating system. Wash coat applied to back. Mask painted side with strippable plastic film. Colorklad by Vincent Brass and Aluminum Company and PAC-CLAD by Peterson Aluminum Corporation are approved. Custom champagne metallic color as selected by the Architect.
2. Miscellaneous Materials and Accessories: (As required by flashing manufacturer).
  - a. Solder: For use with steel or copper, provide 50 - 50 tin/lead solder (ASTM B 32), with rosin flux.
  - b. Fasteners: Same metal as flashing/sheet metal or, other noncorrosive metal as recommended by sheet manufacturer. Match finish of exposed heads with material being fastened.
  - c. Bituminous Coating: FS TT-C-494 or SSPC - Paint 12, solvent type bituminous mastic, nominally free of sulfur, compounded for 15-mil dry film thickness per coat.
  - d. Mastic Sealant: Polyisobutylene; nonhardening, nonskinning, nondrying, nonmigrating sealant.
  - e. Elastomeric Sealant: Generic type recommended by manufacturer of metal and fabricator of components being sealed; comply with FS TT-S-0027, TT-S-00230, or TT-S-001543.
  - f. Epoxy Seam Sealer: 2-part noncorrosive metal seam cementing compound, recommended by manufacturer for exterior/interior nonmoving joints including riveted joints.
  - g. Adhesives: Type recommended by flashing sheet manufacturer for waterproof/weather-resistant seaming and adhesive application of flashing sheet.
  - h. Paper Slip Sheet: 5-lb rosin-sized building paper.
  - i. Polyethylene Underlayment: 6-mil carbonated polyethylene film; FS L-P-512.
  - j. Reglets: Metal or plastic units of the type and profile indicated, compatible with flashing indicated, noncorrosive.
  - k. Metal Accessories: Provide sheet metal clips, straps, anchoring devices and similar accessory units as required for installation of work, matching or compatible with material being installed, noncorrosive, size and gage required for performance.
  - l. Elastic Flashing Filler: Closed-cell polyethylene or other soft closed-cell material recommended by elastic flashing manufacturer as filler under flashing loops to ensure movement with minimum stress on flashing sheet.
  - m. Roofing Cement: ASTM D 4586, Type I, asbestos free, asphaltic based.

2.2 FABRICATED UNITS:

- A. General Metal Fabrication: Shop fabricate work to greatest extent possible. Comply with details shown, and with applicable requirements of SMACNA "Architectural Sheet Metal Manual" and other recognized industry practices. Fabricate for waterproof and weather resistant performance; with expansion provisions for running work, sufficient to permanently prevent leakage, damage or deterioration of the work. Form work to fit substrates. Comply with material manufacturer instructions and recommendations. Form exposed sheet metal work without excessive oil-canning, buckling and tool marks, true to line and levels as indicated, with exposed edges folded back to form hems.
- B. Seams: Fabricate nonmoving seams in sheet metal with flat-lock seams. For metal

1 other than aluminum, tin edges to be seamed, form seams, and solder. Form aluminum  
2 seams with epoxy seam sealer; rivet joints for additional strength where required.

- 3  
4 C. Expansion Provisions: Where lapped or bayonet type expansion provisions in work  
5 cannot be used, or would not be sufficiently water/weatherproof, form expansion joints of  
6 intermeshing hooked flanges, not less than 1 inch deep, filled with mastic sealant  
7 (concealed within joints).  
8  
9 D. Sealant Joints: Where movable, nonexpansion type joints are indicated or required for  
10 proper performance of work, form metal to provide for proper installation of elastomeric  
11 sealant, in compliance with industry standards.  
12  
13 E. Separations: Provide for separation of metal from noncompatible metal or corrosive  
14 substrates by coating concealed surfaces at locations of contact, with bituminous coating  
15 or other permanent separation as recommended by manufacturer/fabricator.  
16  
17 F. Flashing reglets: Extruded aluminum, alloy 6063-T5, standard mill finish. Approved  
18 products are as follows:  
19  
20 1. Cushion Lock B-2; Superior Concrete Accessories, Inc.  
21 2. Temline; Tremco  
22  
23 G. Scuppers, Downspouts and Conductor Heads:  
24  
25 1. Shop fabricate metal scuppers, downspouts, conductor heads, metal flashing  
26 and similar items to comply with profiles and sizes indicated and to comply with  
27 standard industry details shown in the SMACNA "Architectural Sheet Metal  
28 Manual." Unless otherwise indicated, provide soldered flat-lock seams and fold  
29 back metal to form a hem on concealed side of exposed edges. Fabricate work  
30 from paint coated sheet steel.  
31  
32

### 33 **PART 3 - EXECUTION**

#### 34 35 3.1 **INSTALLATION REQUIREMENTS:**

- 36  
37 A. General: Except as otherwise indicated, comply with manufacturer's installation  
38 instructions and recommendations, and with SMACNA "Architectural Sheet Metal  
39 Manual." Anchor units of work securely in place by methods indicated, providing for  
40 thermal expansion of metal units; conceal fasteners where possible, and set units true to  
41 line and level as indicated. Install work with laps, joints and seams which will be  
42 permanently watertight and weatherproof.  
43  
44 B. Underlayment: Where stainless steel or aluminum is to be installed directly on  
45 cementitious or wood substrates, install a course of paper slip sheet and a course of  
46 polyethylene underlayment.  
47  
48 C. Bed flanges of work in a thick coat of bituminous roofing cement where required for  
49 waterproof performance.  
50  
51 D. Install reglets to receive counter flashing in manner and by methods indicated. Where  
52 shown in concrete, furnish reglets to trades of concrete work for installation as work of  
53 Division 3 sections. Where shown in masonry, furnish reglets to trades of masonry work,  
54 for installation as work of Division 4 sections.  
55  
56 E. Install counterflashing in reglets, either by snap-in seal arrangement, or by wedging in  
57 place for anchorage and filling reglet with mastic or elastomeric sealant, as indicated and

1 depending on degree of sealant exposure.  
2

3 F. Install elastic flashing without stretching. Install elastic flashing filler strips to provide for  
4 movement by forming loops or bellows in width of flashing. Locate filler strips to facilitate  
5 complete drainage of water from flashing. Seam flashing sheets with adhesive, and  
6 anchor edges in manner indicated.  
7

8 G. Nail flanges of expansion joint units to curb nailers, at maximum spacing of 6 inches.  
9 Complete seams at joints between units, to form a continuous waterproof system.  
10

11 H. Install continuous gutter guards on gutters, arranged as hinged units to swing open for  
12 cleaning gutters. Install beehive type strainer-guard at conductor heads, removable for  
13 cleaning downspouts.  
14

15 3.2 CLEANING AND PROTECTION:  
16

17 A. Clean exposed metal surfaces, removing substances which might cause corrosion of  
18 metal or deterioration of finishes.  
19

20 B. Protection: Installer shall advise Contractor of required procedures for surveillance and  
21 protection of flashings and sheet metal work during construction, to ensure that work will  
22 be without damage or deterioration, other than natural weathering, at time of substantial  
23 completion.  
24

25  
26 END SECTION 07 62 00

1 **SECTION 07 72 00 - ROOF ACCESSORIES**  
2

3 **PART 1 - GENERAL**  
4

5 1.1 RELATED DOCUMENTS:  
6

- 7 A. Applicable provisions of Division 1 shall govern work under this Section.  
8

9 1.2 DESCRIPTION OF WORK:  
10

- 11 A. The extent and locations of roof accessories is indicated on the drawings and by  
12 provisions of this section.  
13

- 14 B. The types of units specified in this section include the following:  
15

- 16 1. Prefabricated curb and support units.  
17

- 18 C. Related sections:  
19

- 20 1. Refer to roofing system section of these specifications for roofing accessories  
21 (not work of this section).  
22

23 1.3 QUALITY ASSURANCE:  
24

- 25 A. Standards: Except as otherwise indicated, comply with applicable provisions of SMACNA  
26 "Architectural Sheet Metal Manual".  
27

28 1.4 SUBMITTALS:  
29

- 30 A. Product Data; Roof Accessories: Submit manufacturer's product specifications, rough-in  
31 diagrams, details, installation instructions and general product recommendations.  
32

- 33 B. Samples; Roof Accessories: Submit two 8 inch square samples of each exposed metal,  
34 color and finish as selected by Architect from manufacturer's standard offerings.  
35  
36

37 **PART 2 - PRODUCTS**  
38

39 2.1 GENERAL PRODUCT REQUIREMENTS:  
40

- 41 A. Provide manufacturers' standard units, modified as necessary to comply with  
42 requirements. Shop fabricate each unit to greatest extent possible.  
43

44 2.2 MATERIALS, GENERAL:  
45

- 46 A. Zinc-Coated Steel: Commercial quality with 0.20 percent copper, ASTM A 525, G90  
47 hot-dip galvanized, mill phosphatized.  
48

- 49 B. Insulation: manufacturer's standard rigid or semirigid board of glass fiber of thicknesses  
50 indicated.  
51

- 52 C. Wood Nailers: Softwood lumber, pressure treated with waterborne preservatives for

1 above ground use, complying with AWPB LP-2; not less than 1-1/2 inch thick.

2  
3 D. Fasteners:

4  
5 1. Same metal as metals being fastened, or nonmagnetic stainless steel or other  
6 noncorrosive metal as recommended by manufacturer. Match finish of exposed  
7 fasteners with finish of material being fastened.

8  
9 E. Gaskets: Tubular or fingered design of neoprene or polyvinyl chloride or block design of  
10 sponge neoprene.

11  
12 F. Bituminous Coating: FS TT-C-494 or SSPC-Paint 12, solvent type bituminous mastic,  
13 nominally free of sulfur, compounded for 15 mil dry film thickness per coating.

14  
15 G. Mastic Sealant: Polyisobutylene; nonhardening, nonskinning, nondrying, nonmigrating  
16 sealant.

17  
18 H. Elastomeric Sealant: Generic type recommended by unit manufacturer, which is  
19 compatible with joint surfaces; comply with FS TT-S-0027, TT-S-00230, or TT-S-001543.

20  
21 I. Roofing Cement: ASTM D 4586, Type I, asbestos free, asphalt based.

22  
23 2.3 UNIT MATERIALS, FABRICATION:

24  
25 A. Prefabricated Curbs/Equipment Supports:

- 26  
27 1. General: Comply with loading and strength requirements as indicated where  
28 units support other work. Coordinate dimensions with rough-in sheets or shop  
29 drawings of equipment to be supported. Fabricate of structural quality sheet steel  
30 (ASTM A 570, Grade as required) which has been prepared for painting and  
31 factory primed and painted with 2 mil thickness of baked-on synthetic enamel,  
32 after fabrication. Fabricate with welded or sealed mechanical corner joints, and  
33 with cant strips and base profile coordinated with roof insulation thickness.  
34 Provide treated wood nailers at tops of curbs, coordinate with thickness of  
35 insulation and roof flashing as indicated, and tapered where necessary to  
36 compensate for roof deck slopes of 1/4 inch per foot and less. Except as  
37 otherwise indicated or required for strength, fabricate units of minimum 14 gage  
38 (0.0747 inches) metal and to minimum height of 12 inches.
- 39 2. Sloping Roofs: Where slope of roof deck exceeds 1/4 inch per foot, fabricate  
40 curb/support units with height tapered to match slope, to result in level installation  
41 of tops of units.  
42  
43

44 **PART 3 - EXECUTION**

45  
46 3.1 INSTALLATION:

47  
48 A. General: Comply with manufacturer's instructions and recommendations. Coordinate with  
49 installation of roof deck and other substrates to receive accessory units, and with roof  
50 insulation, roofing and flashing; as required to ensure that each element of the work  
51 performs properly, and that combined elements are waterproof and weather tight. Anchor  
52 units securely to supporting structural substrates, adequate to withstand lateral and  
53 thermal stresses as well as inward and outward loading pressures.

54  
55 B. Isolation: Where metal surfaces of units are to be installed in contact with noncompatible  
56 metal or corrosive substrates, including wood, apply bituminous coating on concealed

1 metal surfaces, or provide other permanent separation.

2  
3 C. Flange Seals: Except as otherwise indicated, set flanges of accessory units in a thick bed  
4 of roofing cement to form a seal.

5  
6 D. Cap Flashing: Where cap flashing is required as component of accessory, install to  
7 provide adequate waterproof overlap with roofing or roof flashing (as counter flashing).  
8 Seal with thick bead of mastic sealant, except where overlap is indicated to be left open  
9 for ventilation.

10  
11 3.2 CLEANING AND PROTECTION:

12  
13 A. Clean exposed metal and plastic surfaces in accordance with manufacturer's instructions.  
14 Touch up damaged metal coatings.

15  
16 B. Installer shall advise Contractor of required procedures for surveillance and protection of  
17 roof accessories; so that units will be without damage or deterioration, other than normal  
18 weathering, at time of substantial completion.

19  
20 C. Clean and polish plastic skylight units, inside and out, not more than 5 days prior to date  
21 of substantial completion.

22  
23  
24 END SECTION 07 72 00



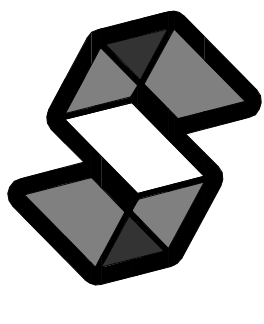

**STRANG**

ARCHITECTURE  
ENGINEERING  
INTERIOR DESIGN

STRANG INC.  
6411 MINERAL POINT ROAD  
MADISON, WI 53705-4393  
T/ 608 278 8202  
F/ 608 278 8204

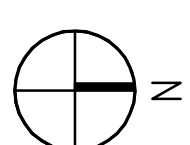
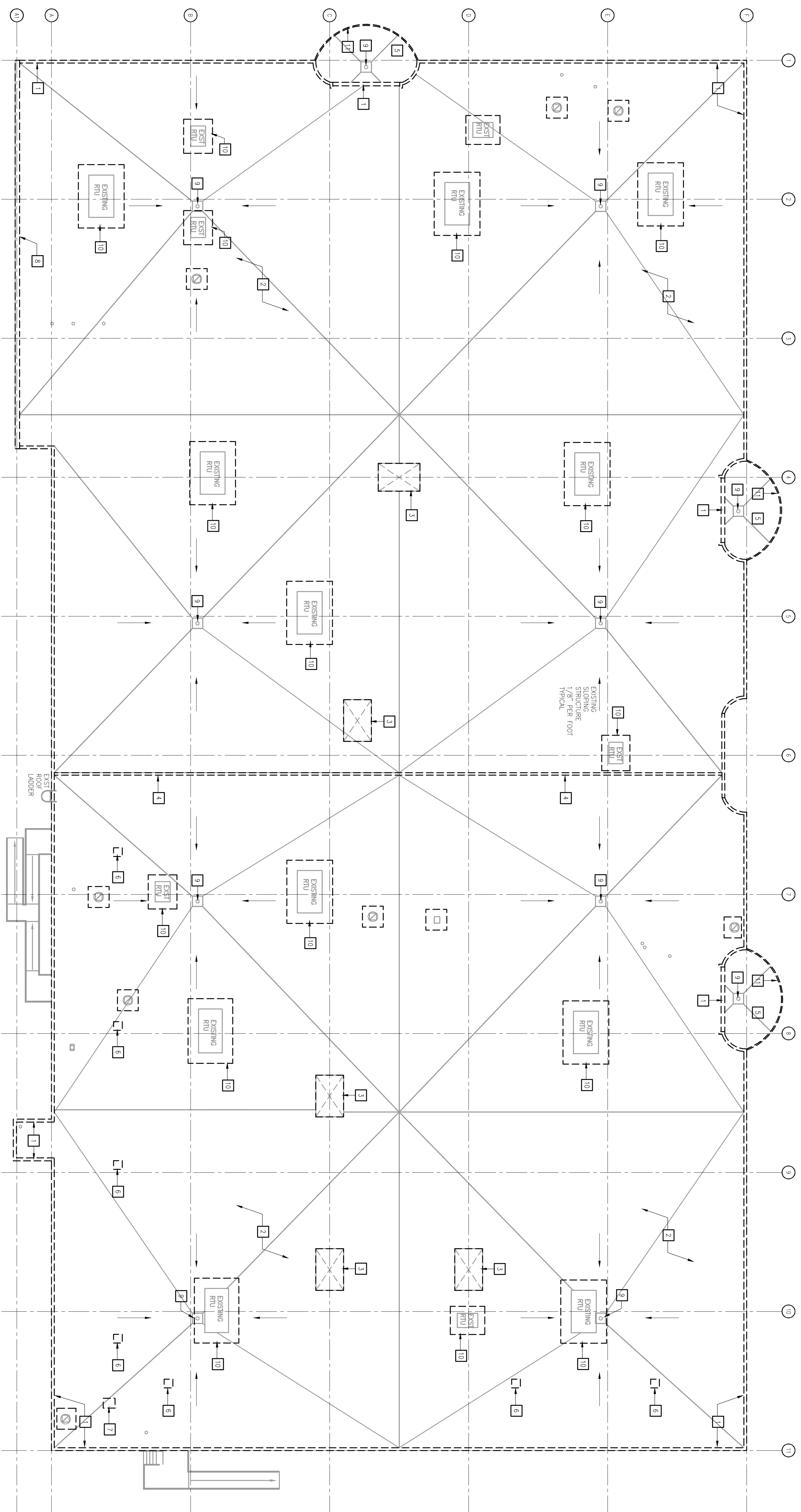

A103

ROOF DEMOLITION PLAN  
SCALE: 1/16" = 1'-0"

**GENERAL ROOF PLAN DEMOLITION NOTES:**

1. CONTRACTOR SHALL COORDINATE ROOF DEMOLITION WITH COUNTY PROJECT MANAGER TO MINIMIZE NOISE ASSUMPTION.
2. EITHER BID PACKAGE WORK SHALL INCLUDE SUPPLY, RISE AS THE REPLACEMENT OF THE EXISTING ROOF TOP UNITS AND CURBS AND THE INSTALLATION OF OVERFLOW ROOF DRAINS.
3. CONTRACTOR SHALL ATTEND PRE-BID TOUR AS NOTED WITHIN THE CONDITIONS.

**SPECIFIC ROOF PLAN DEMOLITION NOTES:**

- 1 REMOVE EXISTING PERIMETER SHEET METAL COPING AND WOOD BLOCKING.
- 2 REMOVE EXISTING ADHERED EPDM ROOFING MEMBRANE AND HARD ROOF INSULATION FROM THE EXISTING ROOF WITH THE EXCEPTION OF DEMOLITION KEY NOTE #10 FOR ADDITIONAL INFORMATION.
- 3 TEMPORARILY REMOVE EXISTING DOME SPLITLIGHT COVER AND EXISTING CURB. REFER TO SHEET A022 FOR ADDITIONAL INFORMATION.
- 4 REMOVE EXISTING EXPANSION JOINT CURB. REFER TO SHEET A022 FOR ADDITIONAL INFORMATION.
- 5 REMOVE EXISTING ADHERED EPDM ROOFING MEMBRANE AT LOW CANOPY.
- 6 REMOVE EXISTING ROOF HATCH AND LADDER BELOW.
- 7 REMOVE SHEET METAL COUNTERFLASHING.
- 8 VERIFY CONDITION OF EXISTING ROOF ISMN AND CLAMPING RING OF THE ROOFING MEMBRANE.
- 9 CUT AND SALVAGE IN PLACE THE ROOF MEMBRANE A MINIMUM OF 36" FROM THE EXISTING PERIMETER AND 18" FROM THE EXISTING CURB WHERE THE EXISTING MEMBRANE RINGS UP AND UNDER THE EXISTING NEW CURBS. REFER TO SHEET A022 FOR ADDITIONAL INFORMATION.
- 10 REMOVE SHEET METAL CANOPY COPING.

ISSUED FOR:  
**BID PACKAGE #1**  
RE-ROOFING  
BID #108074  
04-28-08

DRAWING SET	BP# #1
COPYRIGHT	2008
STRANG, INC.	
FILE NAME	2007070_A103.DWG
REVISIONS	
DRAWN	JMC
CHECKED	LLB
DATE	04-28-08
PROJECT NO.	2007070
PROJECT TITLE	DANE COUNTY JOB CENTER REMODEL REROOFING BID# 108074
1819 ABERG AVENUE MADISON, WISCONSIN	

SHEET TITLE  
**ROOF DEMOLITION PLAN**

SHEET NO.  
**A103**



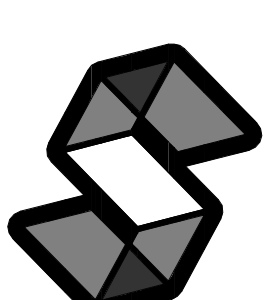

STRANG

ARCHITECTURE  
ENGINEERING  
INTERIOR DESIGN

STRANG INC.  
6411 WINTERL POND ROAD  
MADISON, WI 53705-4398  
P: 608.278.8202  
F: 608.278.8234

- GENERAL ROOF PLAN NOTES:**
1. CONTRACTOR SHALL COORDINATE ROOF INSTALLATION WITH COUNTY PRODUCT NUMBERS TO AVOID DISCREPANCY.
  2. ALTERNATE #1 - PROVIDE TYP ROOFING MEMBRANE IN LIEU OF BASE BID ROOFING MEMBRANE PER SPECIFICATIONS.
  3. CONTRACTOR SHALL INCLUDE IN BID PACKAGE #11 PRICE TAG COST OF ALL ROOFING MATERIALS AND SUPPLIES TO BE INSTALLED OVER NEW MECHANICAL ROOFTOP CURB WHICH WILL BE THE RESPONSIBILITY OF THE ROOFING CONTRACTOR. THE INSTALLED ROOFING SHALL BE IDENTIFIED AS TO THE SPECIFICATION FEET FROM THE EXISTING ROOF FINISH. ALL ROOFING WORKER WORKMAN SHALL BE IDENTIFIED AS TO THE ROOFING MEMBRANE WITHOUT.
  4. CONTRACTOR SHALL ATTEND PRE-BID TOUR AS NOTED WITHIN THE SPECIFICATIONS.

**SPECIFIC ROOF PLAN NOTES:**

1. ADHERED EPDM ROOFING MEMBRANE OVER BASE BID INSULATION AT EXISTING CANOPY. MATCH EXISTING INSULATION THICKNESS AT EXISTING ROOF DRAIN AND PENETRATOR.
2. SHEET METAL CORNING AND TREATED WOOD BLOCKING, SHEET METAL COLOR TO MATCH EXISTING. REFER TO DETAIL 2/A202.
3. REPLACE EXISTING SKYLIGHT PENETRATOR CURB AND FRAMEWORK WITH NEW SKYLIGHT PENETRATOR CURB AND FRAMEWORK. PROVIDE ROOF EXPANSION JOINT PER DETAIL 3/A202 AT EXISTING EXPANSION JOINT LOCATION.
4. REMOVE ROOF PANEL COVER AT THE REAR LOCATION (4, 17, 18). REFER TO DETAIL 4/A202 FOR TYPICAL ROOFING DETAIL AT ROOF PANEL. VERIFY CONDITION OF CLAMPING RING AND REPLACE AS NECESSARY UP TO CONTRACTOR. REFER TO DETAIL 7.2/A202 FOR TYPICAL ROOFING DETAILS.
5. MIN. EXISTING ROOF OPENING WITH 22 GAUGE CORRUGATED METAL ROOF DECK TO MATCH EXISTING PROFILE OVERLAP DECK FIELD WELD PENETRATOR.
6. PROVIDE ADDITIONAL TREATED WOOD BLOCKING AT EXISTING LOW OF LOW PARAPET SHOWN SHADDED.
7. 3 PCE SHEET METAL CORNING. REFER TO DETAIL 6/A202.
8. PRE-FINISHED SHEET METAL SCUPPER. REFER TO DETAIL 11/A202 FOR TYPICAL DETAIL.
9. RAIN ROOFING MEMBRANE UP AND OVER EXISTING EQUIPMENT CURB. PROVIDE ADDITIONAL TREATED WOOD BLOCKING ON TOP OF CURB. CONTRACTOR SHALL FIELD VERIFY EXISTING CONDITIONS.
10. INSULATION CORNER AT EXISTING ROOFTOP SKYLIGHT.
11. BID PACKAGE #2 INSULATION CORNER AT EXISTING SKYLIGHT EQUIPMENT CURB FOR COORDINATION OF ROOFING STRIKE LOCATIONS.

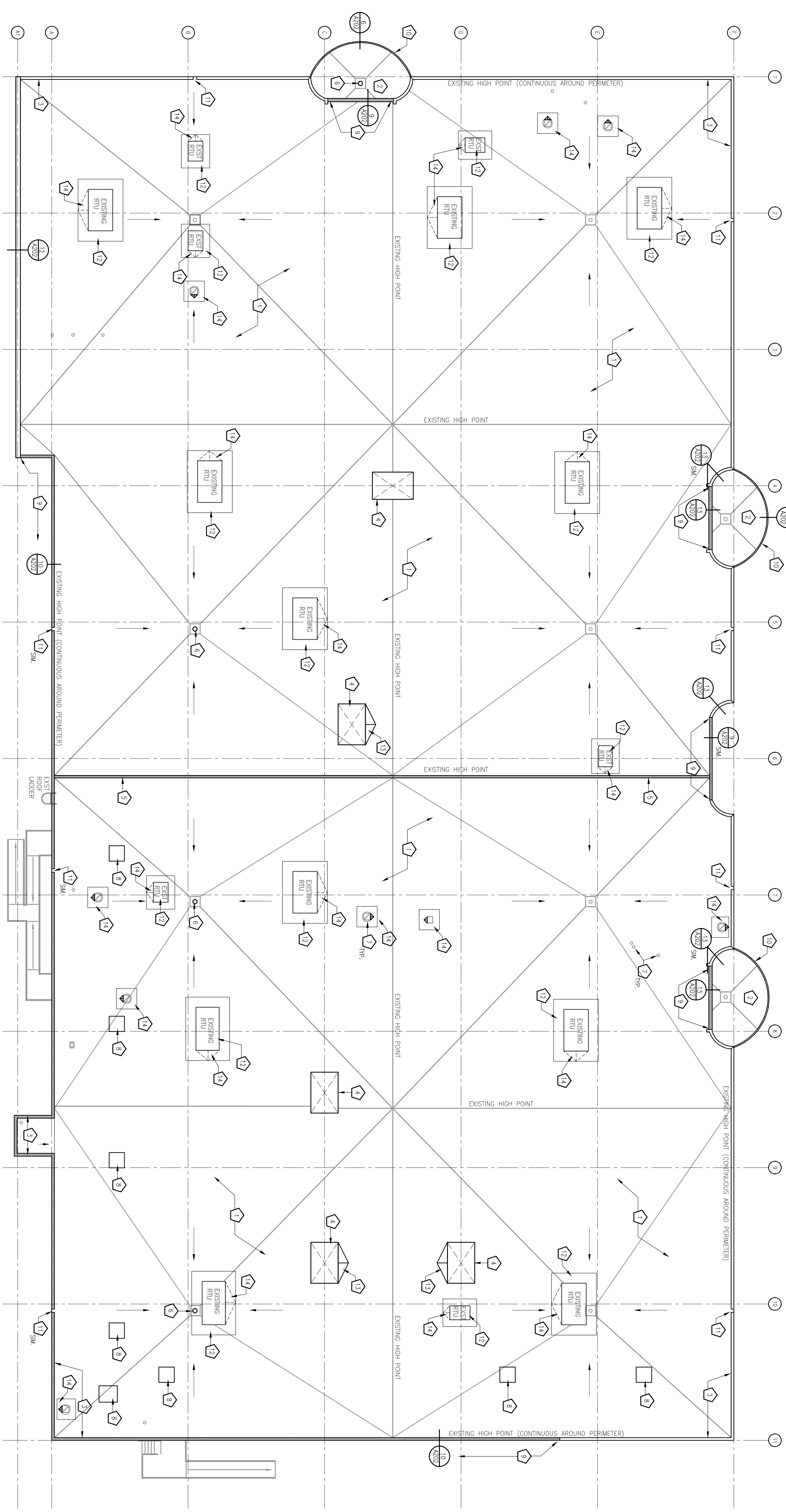

1 ROOF PLAN  
SCALE: 1/16" = 1'-0"

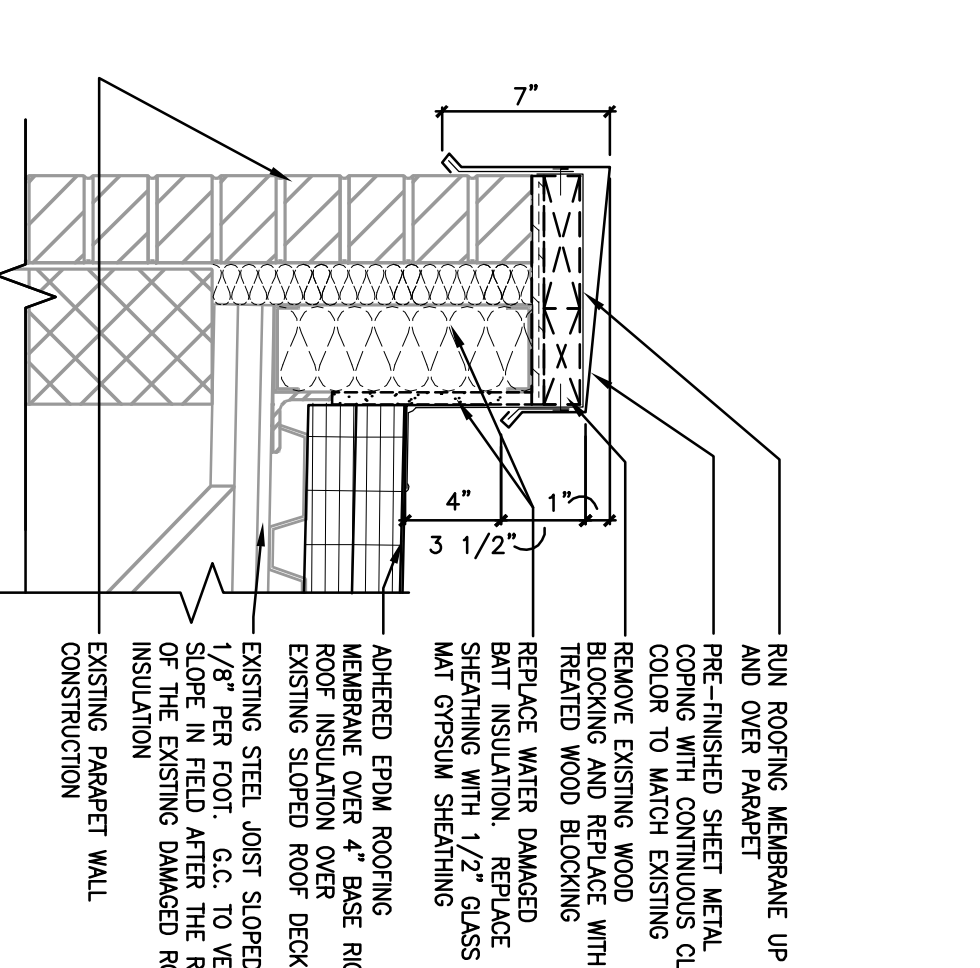

2 TYPICAL ROOF EDGE DETAIL  
SCALE: 1 1/2" = 1'-0"

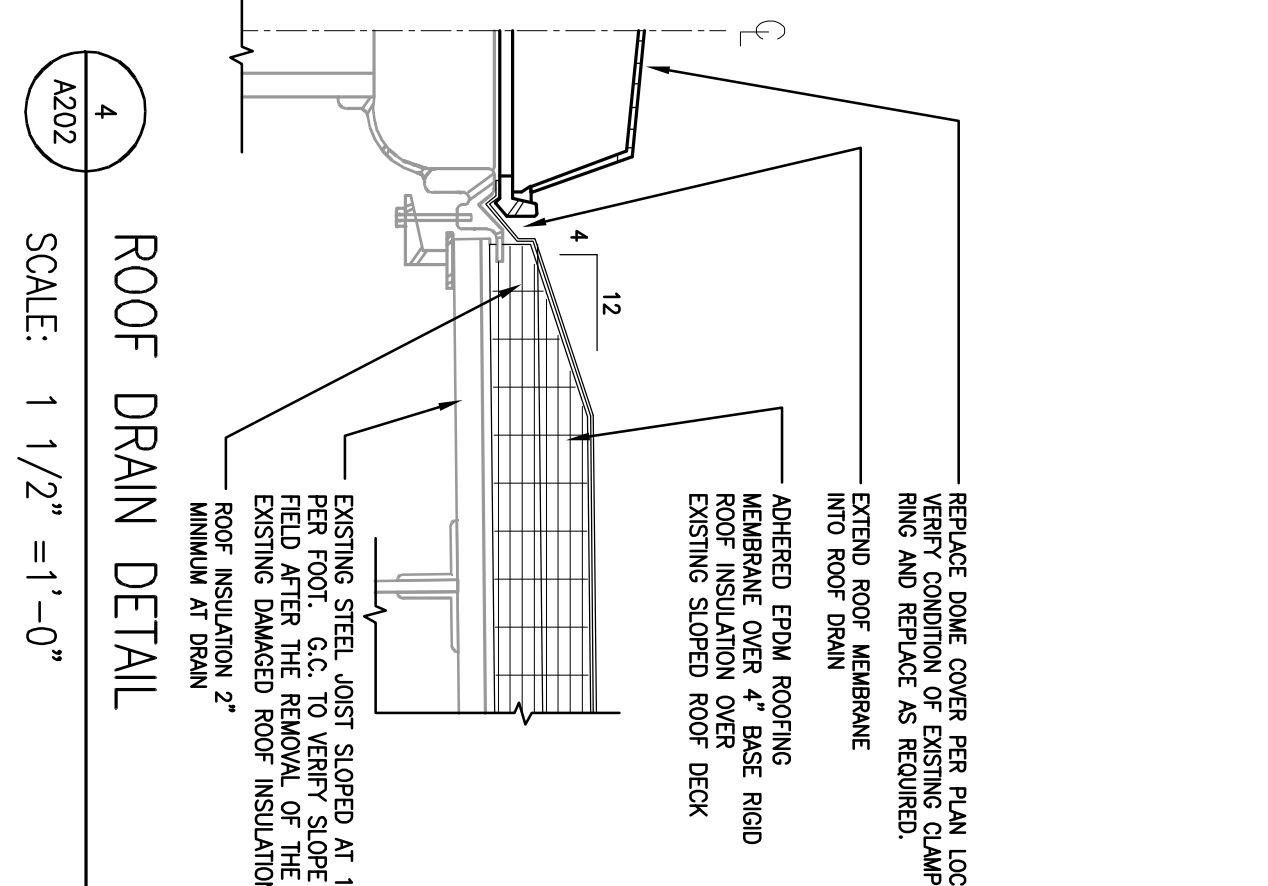

4 ROOF DRAIN DETAIL  
SCALE: 1 1/2" = 1'-0"

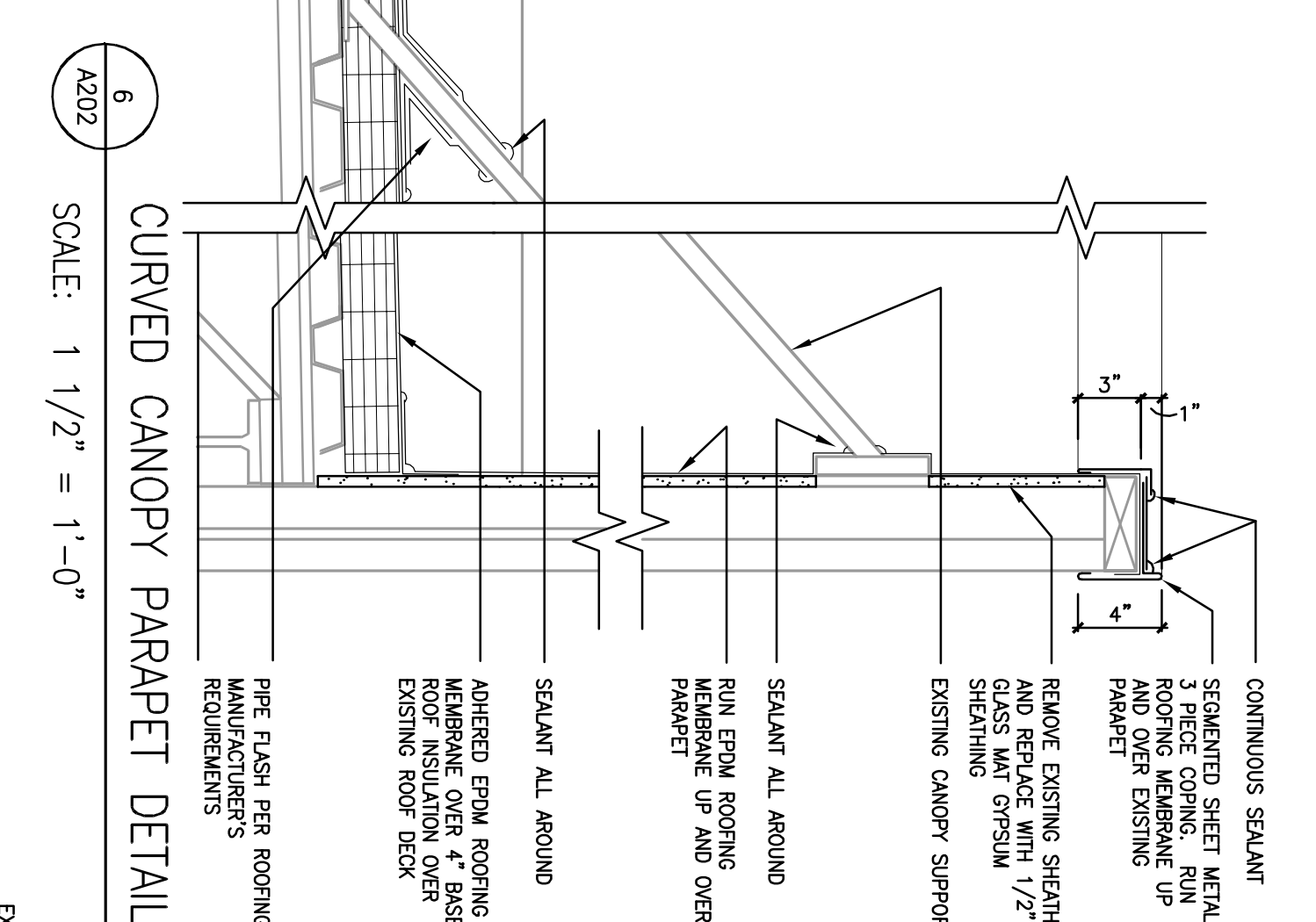

6 CURVED CANOPY PARAPET DETAIL  
SCALE: 1 1/2" = 1'-0"

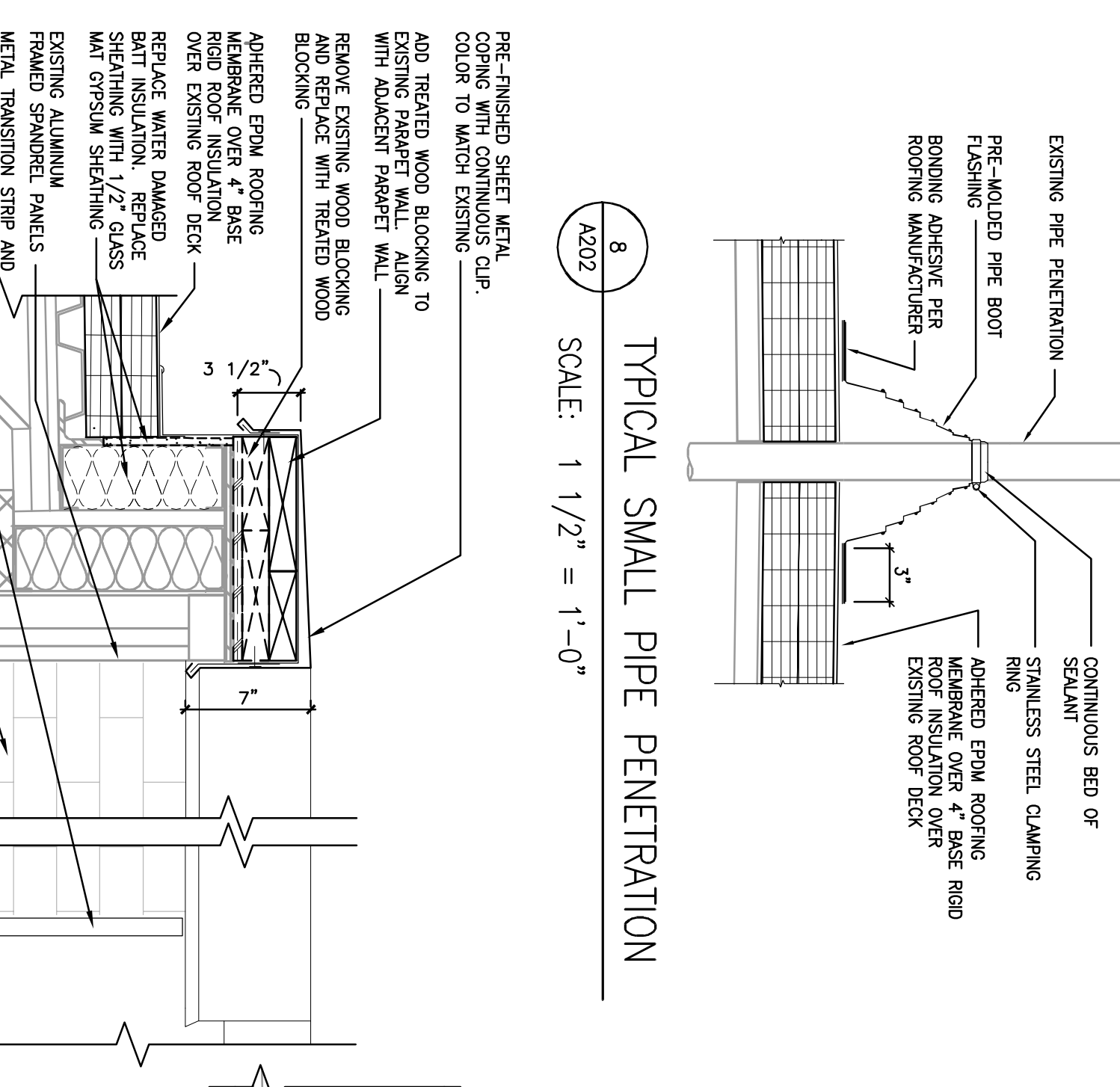

8 TYPICAL SMALL PIPE PENETRATION  
SCALE: 1 1/2" = 1'-0"

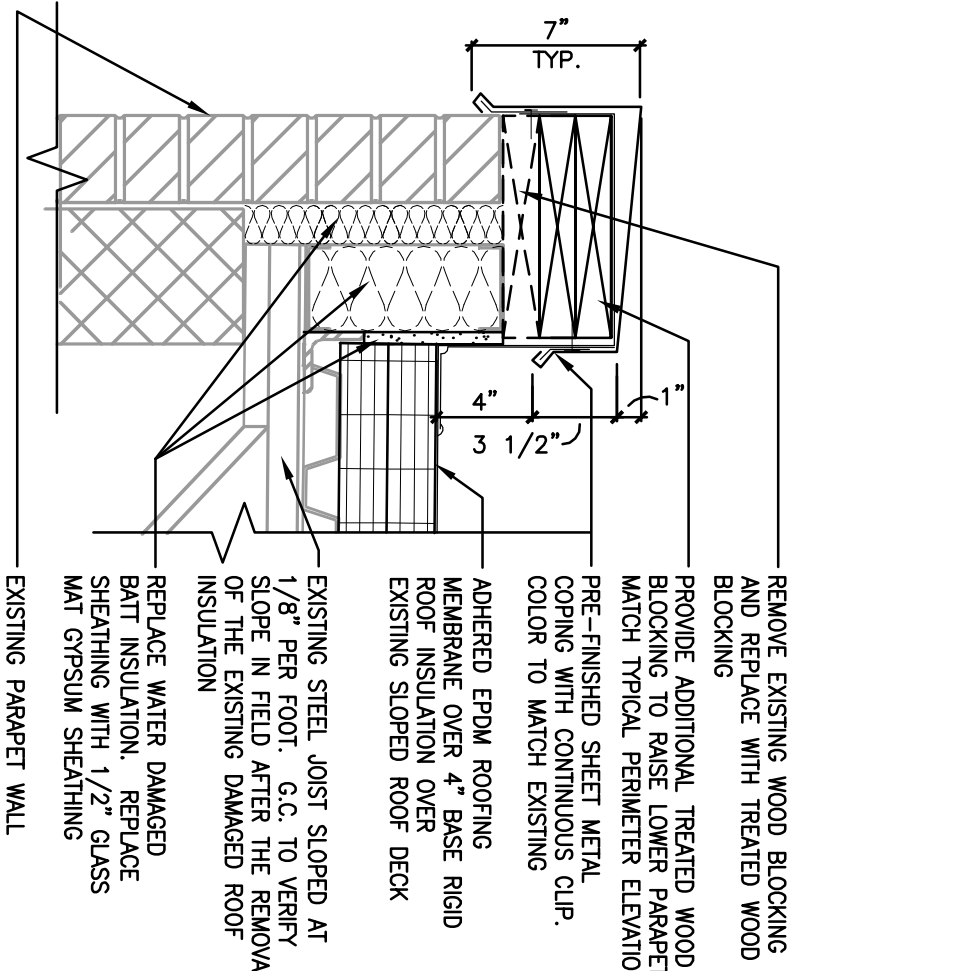

10 LOW ROOF EDGE INFILL DETAIL  
SCALE: 1 1/2" = 1'-0"

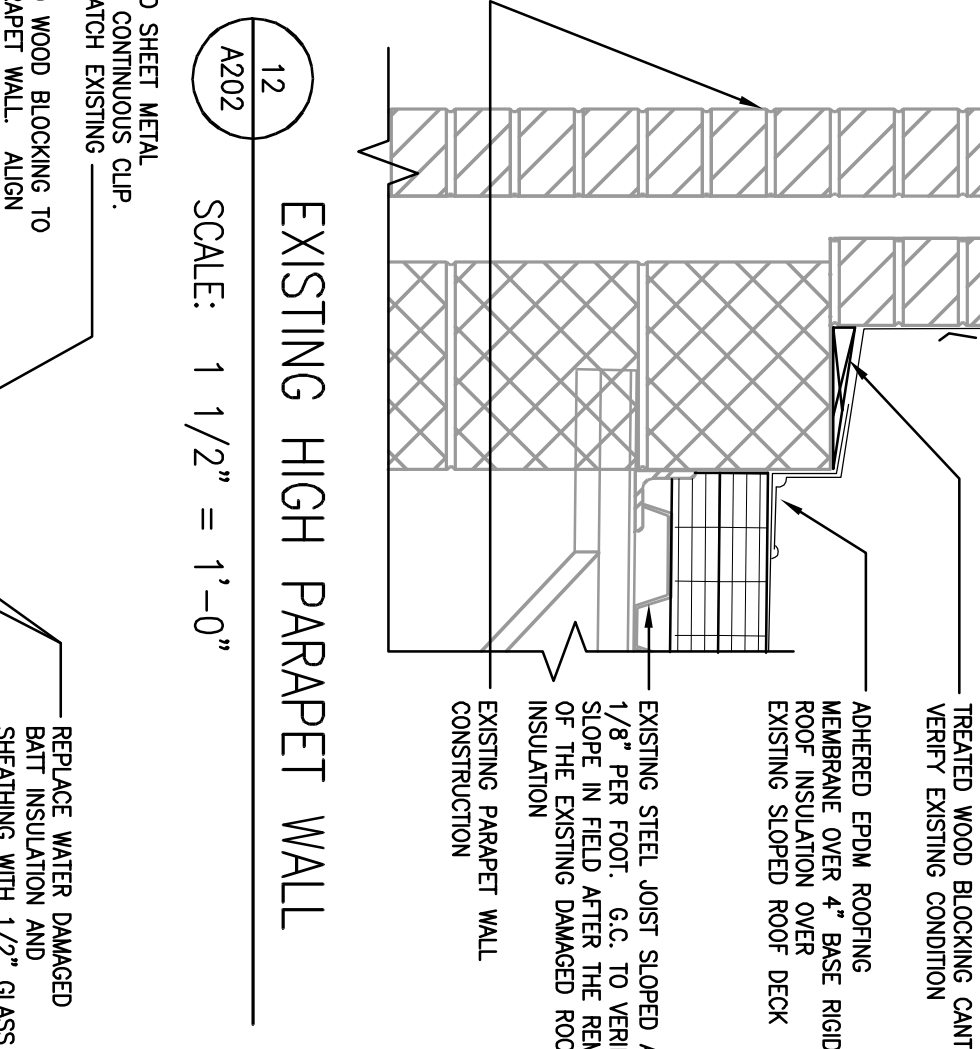

12 EXISTING HIGH PARAPET WALL  
SCALE: 1 1/2" = 1'-0"

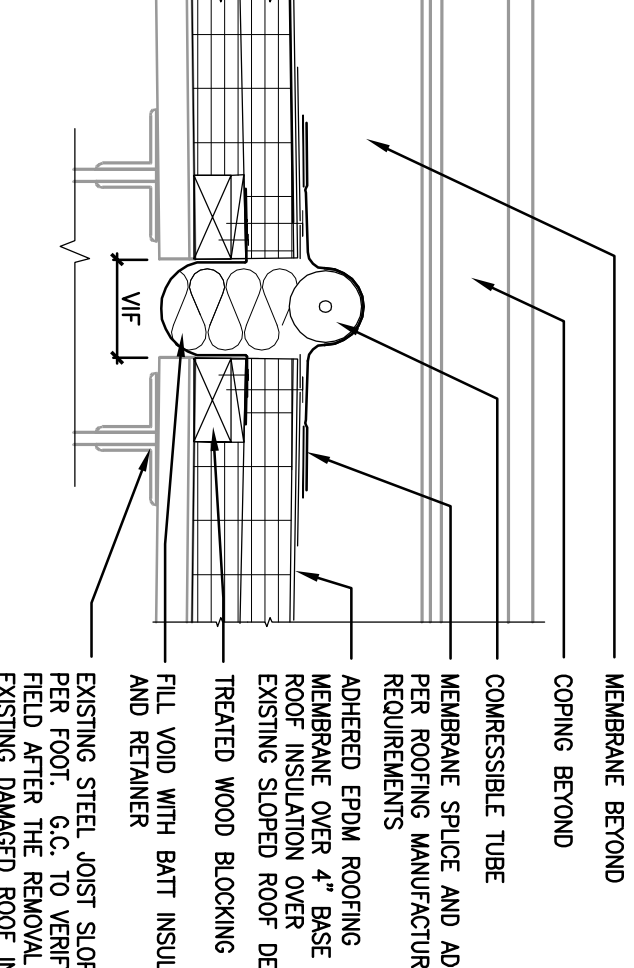

3 EXPANSION JOINT DETAIL  
SCALE: 1 1/2" = 1'-0"

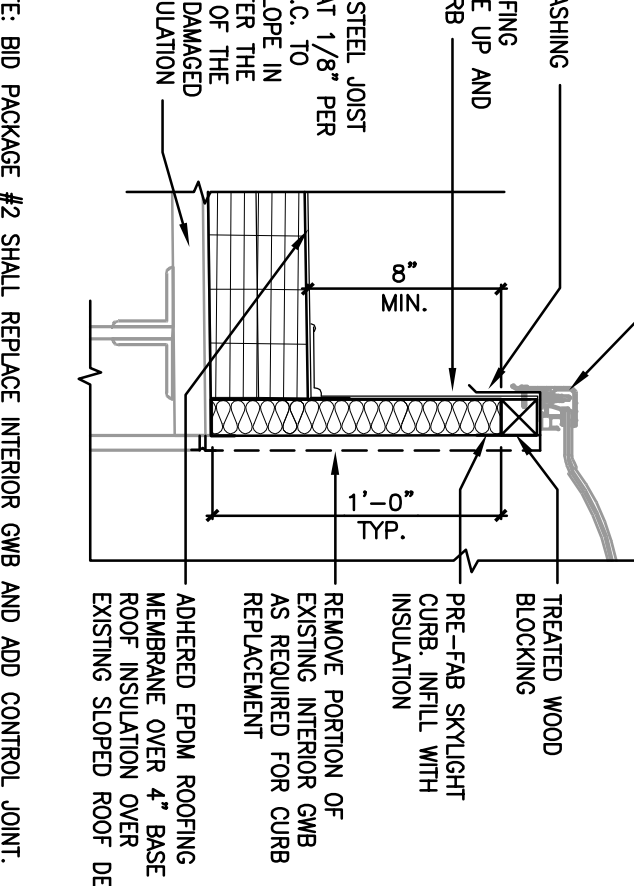

5 SKYLIGHT CURB DETAIL  
SCALE: 1 1/2" = 1'-0"

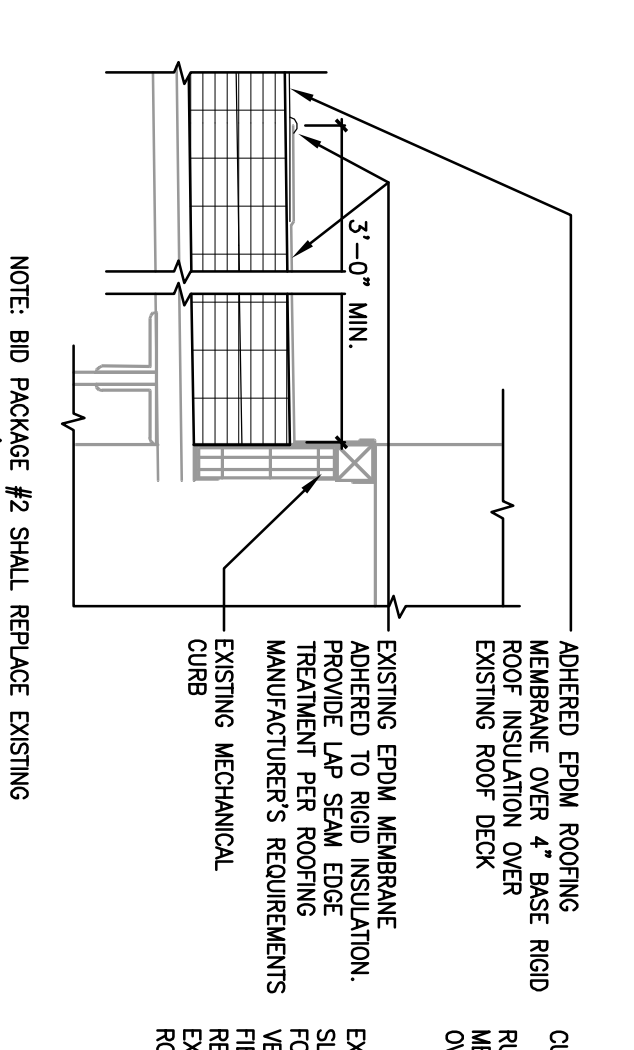

7 MECHANICAL CURB DETAIL  
SCALE: 1 1/2" = 1'-0"

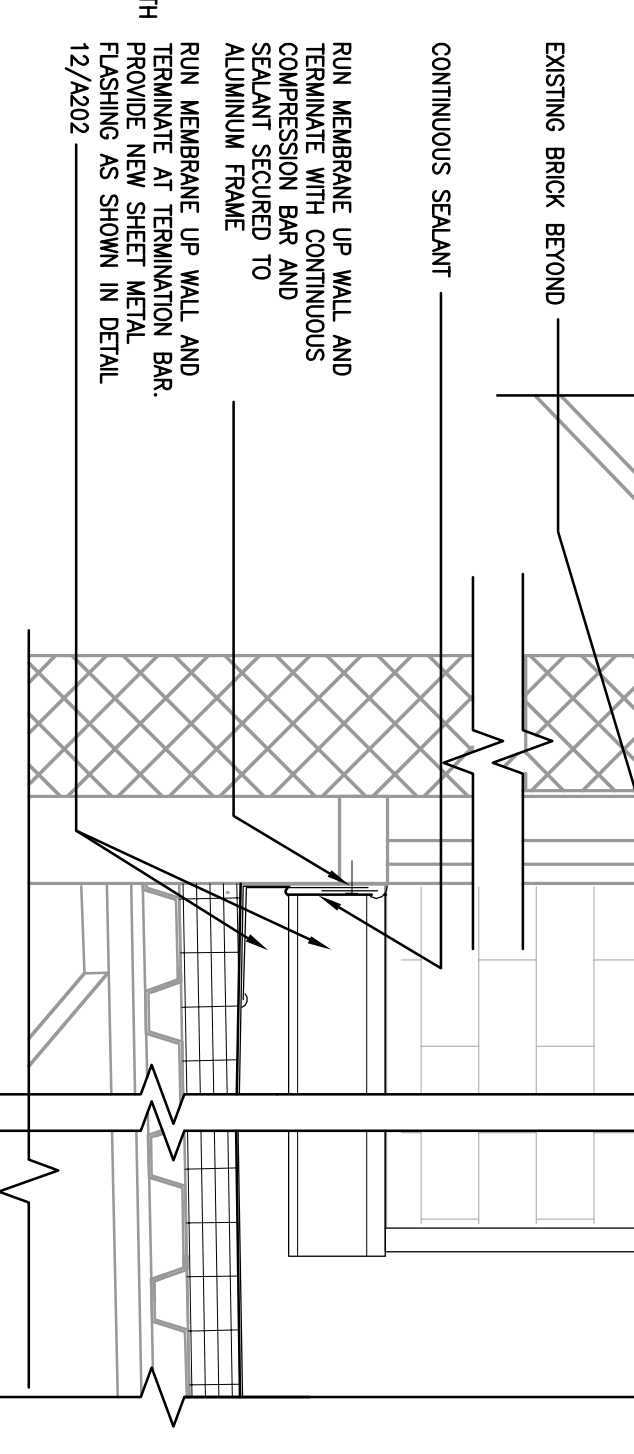

9 REAR CANOPY ROOF EDGE  
SCALE: 1 1/2" = 1'-0"

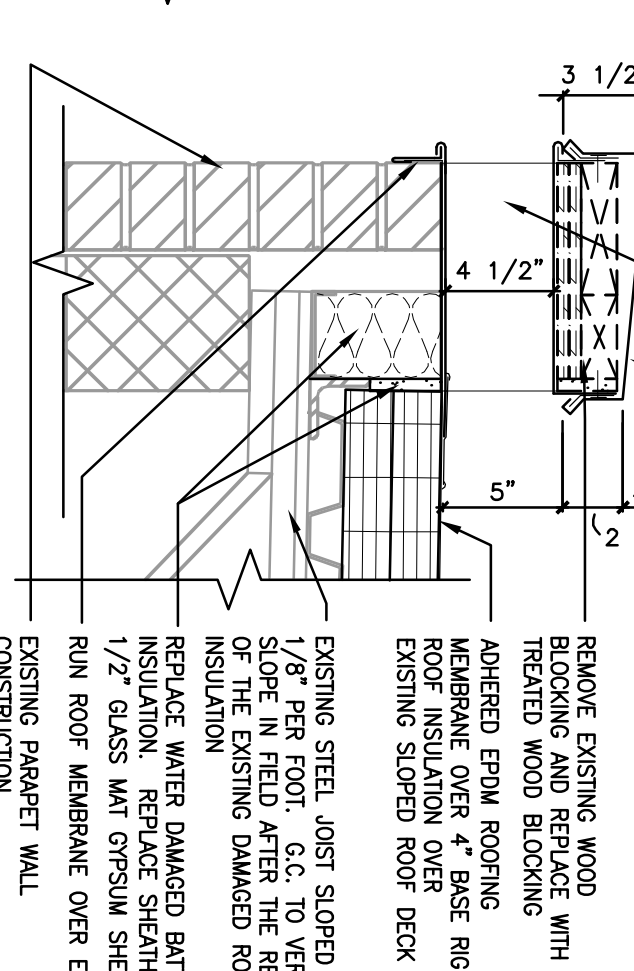

11 OVERFLOW SCUPPER DETAIL  
SCALE: 1 1/2" = 1'-0"

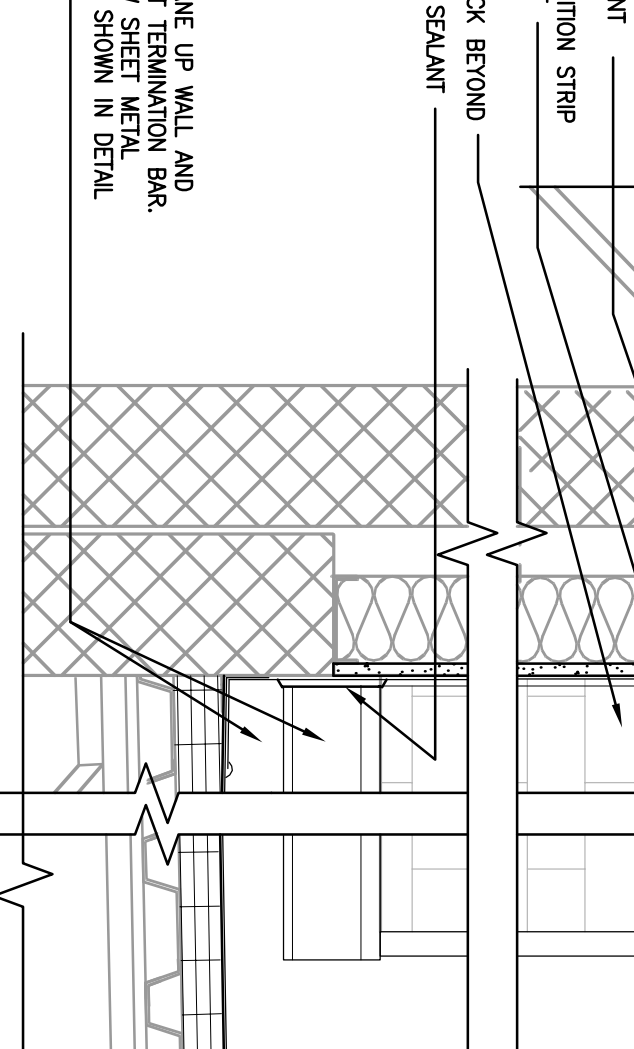

13 REAR CANOPY ROOF EDGE  
SCALE: 1 1/2" = 1'-0"

ISSUED FOR:  
**BID PACKAGE #1**  
**RE-ROOFING**  
**BID #108074**  
**04-28-08**

DRAWING SET  
CONTRACT NO. 2008  
FILE NAME 2007070\_A202.DWG  
REVISIONS

DRAWN JMC  
CHECKED LLB  
DATE 04-28-08  
PROJECT NO. 2007070  
PROJECT TITLE  
DANE COUNTY JOB CENTER REMODEL REROOFING  
BID# 108074

1819 ABERG AVENUE  
MADISON, WISCONSIN  
SHEET TITLE  
**ROOF PLAN & ROOF DETAILS**  
SHEET NO.  
**A202**