

RFP NO. 315033

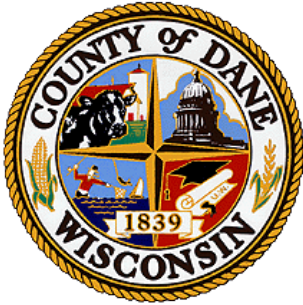

DANE COUNTY DEPARTMENT OF PUBLIC WORKS,
HIGHWAY AND TRANSPORTATION

PUBLIC WORKS SOLID WASTE DIVISION
1919 ALLIANT ENERGY CENTER WAY
MADISON, WISCONSIN 53713

**REQUEST FOR PROPOSALS NO. 315033
RE-BID C&D MATERIALS RECOVERY FACILITY EQUIPMENT
DANE COUNTY SANITARY LANDFILL SITE #2
7102 U.S. HIGHWAY 12 & 18
MADISON, WISCONSIN**

Due Date / Time: **THURSDAY, JUNE 25, 2015 / 2:00 P.M.**

Location: **PUBLIC WORKS OFFICE**

Performance / Payment Bond: **50% OF CONTRACT AMOUNT**

Bid Deposit: **5% OF BID AMOUNT**

FOR INFORMATION ON THIS REQUEST FOR PROPOSALS, PLEASE CONTACT:

MIKE RUIPER, SPECIAL PROJECTS MANAGER
TELEPHONE NO.: 608/266-4990
FAX NO.: 608/267-1533
E-MAIL: RUPIPER.MICHAEL@COUNTYOFDANE.COM



County Executive
Joseph T. Parisi

DANE COUNTY DEPARTMENT of PUBLIC WORKS, HIGHWAY and TRANSPORTATION

1919 Alliant Energy Center Way ♦ Madison, Wisconsin 53713
Phone: (608) 266-4018 ♦ Fax: (608) 267-1533

Commissioner / Director
Gerald J. Mandli

June 4, 2015

INVITATION FOR PROPOSALS

You are invited to submit a Proposal for RFP No. 315033 to provide professional design and construction services for a C&D Material Recovery Facility sorting system at the Dane County Landfill Site #2 in Madison, WI. The Proposals are due on or before **2:00 p.m., Thursday, June 25, 2015**. A 5% bid deposit and a 50% performance bond are required for this project. This is a re-bid of a previously issued Request for Proposals.

SPECIAL INSTRUCTIONS

Please be sure to complete one unbound original and four bound copies of the entire proposal package. To return your proposal, please follow these instructions:

1. Place the signed Signature Page on top as page 1.
2. Place the signed Fair Labor Practices Certification after the Signature Page as page 2.
2. Place the Proposal information after Fair Labor Practices Certification.
3. Clearly label your envelope containing your proposal in the lower left-hand corner as follows:
“Proposal No. 315033
Re-Bid C&D Material Recovery Facility Equipment
2:00 p.m., Thursday, June 25, 2015”
4. Mail to:
Mike Rupiper, Special Projects Manager
Dane County Department of Public Works, Highway & Transportation
1919 Alliant Energy Center Way
Madison, Wisconsin 53713

If any additional information about this Request for Proposals is needed, please call Mike Rupiper at (608) 266-4990 or send email to rupiper.michael@countyofdane.com.

Sincerely,

Mike Rupiper

Special Projects Manager

Encl.: Request for Proposals No. 315033 Package

DOCUMENT INDEX FOR RFP NO. 315033

PROPOSAL REQUIREMENTS

- RFP Cover
- RFP Cover Letter
- Documents Index
- Invitation to Propose (Legal Notice)
- Signature Page and Additional Dane County Requirements
- Proposal Form
- Fair Labor Practices Certification
- Equal Benefits Compliance Payment Certification
- Requested Services and Business Information

APPENDICES

| | |
|------------|-------------------------------|
| Appendix A | Specifications |
| Appendix B | Plans |
| Appendix C | Standard Terms and Conditions |

LEGAL NOTICE

INVITATION TO PROPOSE

Dane County Public Works, Highway & Transportation Dept., 1919 Alliant Energy Center Way, Madison, WI 53713, will receive sealed Proposals until:

2:00 P.M., THURSDAY, JUNE 25, 2015

REQUEST FOR PROPOSALS NO. 315033

RE-BID C&D MATERIAL RECOVERY FACILITY EQUIPMENT

DANE COUNTY SANITARY LANDFILL SITE #2

7102 U.S. HIGHWAY 12 & 18

MADISON, WISCONSIN 53718

Dane County is inviting Proposals for the provision of professional design and construction services for a C&D Material Recovery Facility sorting system. This is a re-bid of a previously issued Request for Proposals. Work includes equipment system final design, provision, installation, and start-up of the equipment, and training on the equipment. C&D recycling equipment to be provided generally includes vibratory equipment (screens and destoner), conveyance equipment (slider bed conveyors, troughing idler conveyors, sorting platform with picking lines, and overhead magnets), dust control equipment, and an equipment control system.

Request for Proposals document may be obtained after **2:00 p.m. on Thursday, June 4, 2015** by downloading it from countyofdane.com/pwbids. Please call Mike Rupiper, Special Projects Manager, at 608/266-4990 for any questions or additional information.

All Proposers must be a registered vendor with Dane County & pay an annual registration fee before award of Contract. Complete Vendor Registration Form at danepurchasing.com/registration or obtain one by calling 608/266-4131.

PUBLISH: JUNE 4 & JUNE 11, 2015 – WISCONSIN STATE JOURNAL



SIGNATURE PAGE

County of Dane
 DEPARTMENT OF ADMINISTRATION
PURCHASING DIVISION
 Room 425, City-County Building
 210 Martin Luther King, Jr. Blvd.
 Madison, Wisconsin 53703
 (608) 266-4131

| | | | |
|--|--------------------------------|--------------------------------|--------------------------|
| COMMODITY / SERVICE: RE-BID C&D MATERIALS RECOVERY FACILITY EQUIPMENT | | | |
| REQUEST FOR PROPOSAL NO.: 315033 | PROPOSAL DUE DATE: 06/25/15 | BID BOND: 5% | PERFORMANCE BOND: 50% |
| PROPOSAL INVALID WITHOUT SIGNATURE THE UNDERSIGNED, SUBMITTING THIS PROPOSAL, HEREBY AGREES WITH ALL TERMS, CONDITIONS AND REQUIREMENTS OF THE ABOVE REFERENCED REQUEST FOR PROPOSAL, AND DECLARES THAT THE ATTACHED PROPOSAL AND PRICING ARE IN CONFORMITY THEREWITH. | | | |
| SIGNATURE OF PROPOSER REQUIRED: (Do Not Type or Print) | | DATE: | |
| SUBMITTED BY: (Typed Name) | | TELEPHONE: (Include Area Code) | |
| COMPANY NAME: | | | |
| ADDRESS: (Street, City, State, Zip Code) | | | |

CONTRACT COMPLIANCE PROGRAM WORKSHEET

- A. Dane County has an established Contract Compliance Program that encourages targeted groups identified below to do business with Dane County, and requires Dane County to actively solicit bids from these businesses.
- B. Information from your response to this worksheet will be entered in the Purchasing Division's Advanced Procurement Systems database to provide data that will be valuable to Dane County's Contract Compliance Program as well as establishing computerized bidder lists for future solicitations. All vendors will be added to the database whether or not they qualify as a targeted business.
- C. **Contract Compliance Program:** Following are abbreviated definitions of ethnic and group codes used by Contract Compliance Program. See reverse side for full definitions:
 - 1. DBE Disadvantaged Business Enterprise
 - 2. MBE Minority Business Enterprise
 - 3. WBE Women Business Enterprise
 - 4. ESB Emerging Small Business
- D. Please select category / categories that best describe your business by marking letter for each column in box provided at bottom of column:

| | | | | | | | |
|----------------------------|-----|----------------------------|-----------------------------------|----------------------------|--------|----------------------------|-----|
| <input type="checkbox"/> D | DBE | <input type="checkbox"/> B | African American | <input type="checkbox"/> L | Male | <input type="checkbox"/> E | ESB |
| <input type="checkbox"/> M | MBE | <input type="checkbox"/> H | Hispanic American | <input type="checkbox"/> F | Female | | |
| <input type="checkbox"/> W | WBE | <input type="checkbox"/> N | Native American / American Indian | | | | |
| | | <input type="checkbox"/> A | Asian Pacific American | | | | |
| | | <input type="checkbox"/> I | Asian-Indian American | | | | |
| ↓ | | ↓ | | ↓ | | ↓ | |
| <input type="checkbox"/> | | <input type="checkbox"/> | | <input type="checkbox"/> | | <input type="checkbox"/> | |

- E. I hereby certify that all of the above information given is true. If no category / categories are marked, I do not meet the requirements for any of the targeted groups.

Signature: _____ Date: _____

(over)

DANE COUNTY CONTRACT COMPLIANCE PROGRAM DEFINITIONS

- A. **Disadvantaged Business Enterprise (DBE):** A small business concern:
1. Which is at least fifty-one percent (51%) owned by one or more socially and economically disadvantaged individuals, or in the case of any publicly owned business, at least fifty-one percent (51%) of the stock of which is owned by one or more socially and economically disadvantaged individuals; and
 2. Whose management and daily business operations are controlled by one or more of the socially and economically disadvantaged individuals who own it.
 3. Socially and Economically Disadvantaged Individuals:
 - a) Any person having a current Section 8 (a) Certification from the Small Business Administration is considered socially and economically disadvantaged.
 - b) Individuals who are citizens of the United States (of lawfully permanent residents) are socially and economically disadvantaged:
 - 1) Women;
 - 2) Black Americans, which includes persons having origins in any of the black racial groups of Africa;
 - 3) Hispanic Americans, which includes persons of Mexican, Puerto Rican, Cuban, Central, or South American, or other Spanish or Portuguese culture or origin, regardless of race;
 - 4) Native Americans, which includes persons who are American Indians, Eskimos, Aleuts, or Native Hawaiians;
 - 5) Asian-Pacific Americans, which includes persons whose origins are from Burma, Thailand, Malaysian, Indonesia, Singapore, Brunei, Japan, China, Taiwan, Laos, Cambodia, the Philippines, Samoa, Guam, the U.S. Trust territories of the Pacific Islands (Republic of Palau), Republic of the Marshall Islands, Federated States of Micronesia, or the Commonwealth of the Northern Mariana Islands; and
 - 6) Asian-Indian Americans, which includes persons whose origins are from India, Pakistan, Bangladesh, Sri Lanka, Bhutan, the Maldives Islands, or Nepal.
- B. **Minority Business Enterprise (MBE):** A minority person(s) owned and controlled independent and valid business concern. A minority person(s) must own fifty-one percent (51%) of the business and must control the management daily operation of the business.
- C. **Women Owned Enterprise (WBE):** A woman or women owned and controlled independent and valid business concern. A woman or women must own fifty-one percent (51%) of the business and must control the management daily operation of the business.
- D. **Emerging Small Business (ESB):**
1. An independent business concern that has been in business for at least one (1) year.
 2. Business is located in the State of Wisconsin.
 3. Business is comprised of less than twenty-five (25) employees.
 4. Business must not have gross sales in excess of three million over the past three (3) years.
 5. Business does not have a history of failing to complete projects.

THIS PAGE IS FOR PROPOSERS' REFERENCE AND NEED NOT BE SUBMITTED WITH PROPOSAL.

PROPOSERS SHOULD BE AWARE OF THE FOLLOWING:

DANE COUNTY VENDOR REGISTRATION PROGRAM

Any person proposing on any County contract must be registered with the Dane County Purchasing Division & pay an annual registration fee. A contract will not be awarded to an unregistered vendor. Complete a Vendor Registration Form at:
www.danepurchasing.com/registration
or obtain one by calling 608/266-4131.

EQUAL BENEFITS REQUIREMENT

By submitting a Proposal, the contractor / consultant acknowledges that a condition of this contract is to provide equal benefits as required by Dane County Code of Ordinances Chapter 25.016. Contractor / Consultant shall provide equal benefits as required by that Ordinance to all required employees during the term of the contract. For more information: www.danepurchasing.com/partner_benefit.aspx

PROPOSAL FORM

PROPOSAL NO. 315033

**PROJECT: RE-BID C&D MATERIALS RECOVERY FACILITY EQUIPMENT
DANE COUNTY LANDFILL SITE #2**

**TO: DANE COUNTY DEPARTMENT OF PUBLIC WORKS, HIGHWAY &
TRANSPORTATION PROJECT MANAGER
1919 ALLIANT ENERGY CENTER WAY
MADISON, WISCONSIN 53713**

EQUIPMENT SCHEDULE:

Include a complete list of the individual equipment components with manufacturer and model number (if applicable). Any used, but properly reconditioned "like new" piece of equipment must be indicated. The specifications describe an acceptable unit. Any deviation from the minimum specifications must be identified in detail in the proposal including a description of how the proposed item/s differ from the bid requirements, along with detailed justification for such deviation.

EQUIPMENT SCHEDULE

| ITEM | DESCRIPTION | MANUFACTURER | PRICE | COMPLIES WITH SPECS |
|------|--|--------------|-------|---------------------|
| 1 | Primary Finger Screen | | \$ | Yes / No |
| 2 | Slider Bed Conveyor (Primary Finger Screen Overs) | | \$ | Yes / No |
| 3 | Slider Bed Conveyor (Picking A-Line) | | \$ | Yes / No |
| 4 | Ferrous Magnet | | \$ | Yes / No |
| 5 | Slider Bed Conveyor (Secondary Finger Screen Infeed) | | \$ | Yes / No |
| 6 | Secondary Finger Screen | | \$ | Yes / No |
| 7 | De-stoner / Air Knife (Single Knife) | | \$ | Yes / No |
| 8 | Slider Bed Conveyor (De-stoner/Air Knife Outfeed) | | \$ | Yes / No |
| 9 | Slider Bed Conveyor (Picking B-Line) | | \$ | Yes / No |
| 10 | Troughing Idler Conveyor (Small Residuals Bunker) | | \$ | Yes / No |
| 11 | Troughing Idler Conveyor (Primary Finger Screen Unders) | | \$ | Yes / No |
| 12 | Slider Bed Conveyor (Fines Bunker Infeed) | | \$ | Yes / No |
| 13 | Dust Collector / Filter | | \$ | Yes / No |

| ITEM | DESCRIPTION | MANUFACTURER | PRICE | COMPLIES WITH SPECS |
|------|--|--------------|-------|---------------------|
| 14 | Aggregate Conveyor | | \$ | Yes / No |
| 15 | Slider Bed Conveyor (Aggregate on Platform) | | \$ | Yes / No |
| 16 | Tilting Hoppers (4) | | \$ | Yes / No |
| 17 | Elevated Picking Line Platform and Drop Chutes | | \$ | Yes / No |
| 18 | Integrated Electrical Controls, and Safety /Shut-down Features | | \$ | Yes / No |
| 19 | Other: | | | |
| 20 | Other: | | | |
| 21 | Other: | | | |
| 22 | Other: | | | |
| 23 | Other: | | | |
| | TOTAL PROPOSED COST | | \$ | |

_____ and _____/100 Dollars
 Written Price

ADDENDA:

Receipt of the following addenda and inclusion of their provisions in this Proposal is hereby acknowledged:

Addendum No(s). _____ through _____

Dated _____

COMPLETION:

Dane County Department of Public Works, Highways, & Transportation / Solid Waste Division must have this project completed no later than December 31, 2015. Assuming this Work can be started by June 30, 2015, what dates can you commence and complete this job?

Commencement Date: _____ Completion Date: _____
 (final, not substantial)

I hereby certify that all statements herein are made on behalf of:

(Name of Corporation, Partnership or Person submitting Bid)

Select one of the following:

1. A corporation organized and existing under the laws of the State of _____, or
2. A partnership consisting of _____, or
3. A person conducting business as _____;

Of the City, Village, or Town of _____ of the State of _____.

I have examined and carefully prepared this Proposal from the associated documents and have checked the same in detail before submitting this Proposal; that I have full authority to make such statements and submit this Proposal in (its) (their) (my) behalf; and that the said statements are true and correct. In signing this Proposal, we also certify that we have not, either directly or indirectly, entered into any agreement or participated in any collusion or otherwise taken any action in restraint of free competition; that no attempt has been made to induce any other person or firm to submit or not to submit a Proposal; that this Proposal has been independently arrived at without collusion with any other proposer, competitor, or potential competitor; that this Proposal has not been knowingly disclosed prior to the Proposal Due Date to another proposal or competitor; that the above statement is accurate under penalty of perjury.

The undersigned further agrees to honor the Proposal for ninety (90) days following the proposal due date.

SIGNATURE: _____
(Bid is invalid without signature)

Print Name: _____ Date: _____

Title: _____

Address: _____

Telephone No.: _____ Fax No.: _____

Email Address: _____

Contact Person: _____

FAIR LABOR PRACTICES CERTIFICATION

The undersigned, for and on behalf of the BIDDER, APPLICANT or PROPOSER named herein, certifies as follows:

- A. That he or she is an officer or duly authorized agent of the above-referenced BIDDER, APPLICANT or PROPOSER, which has submitted a bid, application or proposal for a contract or agreement with the county of Dane.

- B. That BIDDER, APPLICANT or PROPOSER has (check one):

_____ not been found by the National Labor Relations Board (“NLRB”) or the Wisconsin Employment Relations Commission (“WERC”) to have violated any statute or regulation regarding labor standards or relations in the seven years prior to the signature date of this Certification.

_____ been found by the National Labor Relations Board (“NLRB”) or the Wisconsin Employment Relations Commission (“WERC”) to have violated any statute or regulation regarding labor standards or relations in the seven years prior to the signature date of this Certification.

Officer or Authorized Agent Signature Date

Printed or Typed Name and Title

Printed or Typed Business Name

NOTE: You can find information regarding the violations described above at: www.nlrb.gov and werc.wi.gov.

For reference, Dane County Ordinance 25.11(28)(a) is as follows:
(28) BIDDER RESPONSIBILITY. (a) Any bid, application or proposal for any contract with the county, including public works contracts regulated under chapter 40, shall include a certification indicating whether the bidder has been found by the National Labor Relations Board (NLRB) or the Wisconsin Employment Relations Committee (WERC) to have violated any statute or regulation regarding labor standards or relations within the last seven years. The purchasing manager shall investigate any such finding and make a recommendation to the committee, which shall determine whether the conduct resulting in the finding affects the bidder’s responsibility to perform the contract.

If you indicated that the NLRB or WERC have found you to have such a violation, you must include copies of any relevant information regarding such violation with your proposal, bid or application.

Include this completed Certification with your bid, application or proposal.

EQUAL BENEFITS COMPLIANCE PAYMENT CERTIFICATION

PURPOSE

25.016(8) of the Dane County Ordinance requires that each contractor receiving payment for contracted services must certify that he or she has complied fully with the requirements of Chapter 25.016 “Equal Benefits Requirement” of the Dane County Ordinances. Such certification must be submitted prior to the final payment on the contract.

This form should be included with a copy of the final contract invoice forwarded to your contract representative at Dane County.

CERTIFICATION

I, _____ certify that
Printed or Typed Name and Title

Printed or Typed Name of Contractor

has complied fully with the requirements of Chapter 25.016 of the Dane County Ordinances “Equal Benefits Requirements”.

Signed _____

Date _____

For questions on this form, please contact Chuck Hicklin at 608-266-4109 or your contract representative at Dane County.

REQUESTED SERVICES AND BUSINESS INFORMATION

1. GENERAL BACKGROUND INFORMATION

- A. Dane County is inviting proposals for design and construction services for a construction and demolition (C&D) Material Recovery Facility sorting system at the Dane County Landfill Site #2 in Madison, WI.
- 1) The C&D waste processing system shall be a pre-engineered system comprised of proven, integrated components and controls, including structures and machinery that are specifically designed to handle typical urban and commercial C&D wastes.
 - 2) The minimum capacity of the system, at the initial in-feed equipment, shall be approximately 25 to 30 tons per hour.
 - 3) A single, qualified vendor shall be responsible for providing the complete C&D processing system, however, the system itself may be composed of equipment and structures provided or manufactured by multiple qualified vendors. The meaning of the word “providing” shall be understood to include overall responsibility to the Owner for: final design, construction layout, shop drawings, component fabrication, shipping, assembly/installation, quality assurance, start-up/shake-down, system warranty, O&M Manual, and operator training.
- B. The Dane County Waste Transfer Station accepted a total of about 27,000 tons of construction and demolition waste in 2013 and 32,400 tons in 2014. The peak monthly acceptance was 3,725 tons. This material is currently transported off-site to a construction and demolition waste recycling facility. The average composition of the material in 2013 and in 2014 is shown in Table 1.

Table 1: Average Material Composition

| Material | 2013 | 2014 |
|---------------------------------|----------------|----------------|
| Unrecyclables | 31.36% | 27.28% |
| Fines - Alternative Daily Cover | 26.30% | 30.91% |
| Clean Wood | 25.18% | 24.56% |
| Mixed Aggregate | 7.12% | 8.86% |
| Drywall | 1.12% | 1.29% |
| Metals | 3.09% | 3.61% |
| Vinyl Siding | 0.29% | 0.30% |
| Cardboard | 1.00% | 1.85% |
| Shingles | 3.98% | 1.32% |
| Misc. | 0.19% | 0.03% |
| Carpet | 0.37% | 0.00% |
| Total | 100.00% | 100.00% |

- C. Dane County is expanding and modifying the existing 20,850 square foot waste transfer station building to create a construction and demolition waste recycling facility at the site under a separate contract. Complete plans and specifications for the planned building modifications may be obtained by downloading the following Archived Documents from countyofdane.com/pwbids:

REQUEST FOR BIDS NO. 315011:
CONSTRUCT C&D MATERIALS RECOVERY FACILITY
DANE COUNTY LANDFILL SITE #2

2. SCOPE OF WORK

- A. The scope of work for the project shall include all of the final design, construction layout, shop drawings, component fabrication, shipping, assembly/installation, quality assurance, start-up/shake-down, system warranty, O&M Manual, and operator training necessary to provide a complete C&D processing system.
- B. Design
1. The C&D system shall be designed to provide maximum opportunity to separate the waste stream into several specific material types, as indicated on the Drawings, using automated and manually-assisted equipment and work stations, integrated with proven personnel safety features in accordance with OSHA regulations, the City of Madison, Wisconsin Building Code, and applicable ANSI Standards for Facility Safety.
 2. The Proposer shall provide all electrical circuit protection and shut-off/alarm devices, control panels, and power and instrumentation wiring circuitry necessary to operate the entire system in an integrated manner and to interface with the power supply. The operation of the system shall be provided by a central computerized screen that will allow automatic and manual over-ride of the system. Owner will provide the primary electrical feed and electrical conduit for the processing system as part of the building modifications project.
 3. The C&D processing system shall be essentially composed of two main processing lines (Line A and Line B) and the major components as shown on the Drawings.
 4. All equipment sizing and design criteria noted are estimated. The Proposer shall be responsible, if they are awarded the contract, for the exact sizing and design capacity of all equipment, to be based on the design throughput at the head of the system provided by Owner, including any adjustment or re-design to electrical wire sizing and control devices for their processing equipment.
 5. All equipment weights are approximate. The process line vendor is responsible for confirming the fully loaded weight of the equipment they will provide, providing adequate load supports, structural support and bracing, and verifying that their system will not overload the concrete floor.
 6. The Drawings represent the overall intent of the Owner for this system, however, they may not indicate every detail necessary or required of the waste processing system. The vendor shall include all hardware, devices, and equipment either necessary or required, whether indicated on the plans or not, so that the system as provided is complete, adequate in capacity, and will be fully operational before turning it over to the Owner.

7. Creative alternatives that would result in cost savings to Dane County are encouraged, provided that the changes are consistent with all of the proposed building facility modifications and the required system capacity.

C. Equipment Purchase and Installation

1. The selected Proposer will be responsible for the purchase, delivery, and installation of all equipment and instrumentation necessary for the project. Except, wood grinding equipment and cardboard baler will be provided and installed by Owner under separate contracts.
2. All equipment sold to Dane County must meet Federal, State and local government standards. A proposal will not be considered if the proposer has failed to show, without a doubt, that the proposal is for regularly manufactured equipment, tried, proven and in current use.

D. Operation & Maintenance Manual

1. Prepare an operation and maintenance manual for the system consisting of text, drawings, manufacturer's equipment specifications, and other documents that describe the steps for operating the system and maintenance requirements of the system.

E. Start-up Testing, Training, and Troubleshooting

1. Field Quality Control: An authorized field representative shall inspect, test, and adjust field assembled components and equipment installation including connections and control system programming modifications, as necessary, and supervise field test performance. The manufacturer's representative shall issue an installation certificate to Dane County confirming that all equipment has been installed in accordance with manufacturer's recommendations.
2. Field Testing: When the system is complete and ready for operation, an authorized field representative shall perform a full load test of the entire system for compliance to the contract documents. Test of equipment shall be made by the Contractor in the presence of the Engineer and the Owner. Owner will supply representative waste for the duration of the test, which shall be a minimum of 2 hours of continuous run time with no stoppages due to a system malfunction or material jam. The equipment tests shall include, but will not be limited to the following:
 - a) The screens and conveyors shall be tested to operate at design capacity.
 - b) Electrical: Readings shall be made of the voltage and amperage draw and recorded on the manufacturer's start-up form.
 - c) Controls: Control primary elements shall be tested to determine satisfactory performance and alarm functions, and emergency stop functions will also be tested.
 - d) Inspection: An inspection of all mechanical and electrical equipment, controls, brackets mountings, seals, conduit, and component features shall be made while the system is being tested to determine performance and compliance with design requirements and the specification.
 - e) Repairs, adjustments and replacement: The Contractor shall make any and all necessary repairs, adjustments and replace any component parts until performance has been demonstrated to the satisfaction of the Owner and Engineer. The Contractor shall bear the cost of any repair, adjustment and replacement.

F. Project Acceptance and Warranty

1. The supplier of the C&D sorting system will provide all warranty services against defects in materials and workmanship for a minimum of one year length from the date of written acceptance of the system by the Owner to the effect that any defective or damaged equipment shall be repaired or replaced without extra cost or obligation to the Owner.

3. PROPOSAL CONTENT

A. Proposers are requested to submit the following information in their proposal, in six distinct sections or divisions:

1. Proposer's cover letter, Signature Page and Fair Labor Practices Certification.
2. Description of Proposer's qualifications, related experience, organization and resources. This description must pay specific attention to the design, installation, and start-up of C&D waste processing systems.
3. Listing of three to five projects completed by the Proposer that are similar to the one being proposed. Listing shall include for each project:
 - a. Brief description of the project including equipment and services provided
 - b. Project references (name of the organization, contact person or responsible official, address, telephone and fax numbers, e-mail address)
4. Description of the approach to the design, installation, and start-up of the project. Include a complete list of the individual equipment components with manufacturer and model number (if applicable) for each component on the Proposal Form. Any used, but properly reconditioned "like new" piece of equipment must be indicated. The specifications describe an acceptable unit. Whenever equipment or materials are identified on Drawings or in Specifications by reference to manufacturer's or vendor's name, trade name, catalog number, and other identifying information, it is intended to establish standards; and any equipment or material of other manufacturers and vendors which will perform adequately duties imposed by general design will be considered equally accepted provided equipment or material so proposed is, in opinion of Owner / Engineer, of equal substance and function. Any deviation from the minimum specifications stated herein must be identified in detail in the proposal including a description of how the proposed item/s differ from the bid requirements, along with detailed justification for such deviation. Bidder shall include photos and schematics as necessary, for complete clarification. Minor variations in specification may be accepted if, in the opinion of County staff, they do not adversely affect the quality, maintenance or performance of the equipment. Product literature may also be included.
5. Proposed schedule with all project tasks for the project, including the final design, equipment delivery, installation, and start-up phases.
6. Complete system costs including all of the design, equipment purchase and installation, start-up testing and troubleshooting, etc., necessary to successfully implement the project on the Proposal Form. The pricing listed in the proposal shall include a detailed breakdown by each major piece of equipment shown on the drawings and specifications for the project.

4. EVALUATION CRITERIA

A. Proposals will be evaluated, scored, and ranked according to the following criteria:

| | |
|--|------------|
| Pricing / Cost Proposal | 70% |
| Approach to Project (Proposed Equipment) | 20% |
| <u>Past Project References</u> | <u>10%</u> |
| Total | 100% |

5. OWNER’S RESPONSIBILITY

- A. Dane County will provide all necessary and available site information to the selected proposer.
- B. Dane County will be responsible for obtaining any permits required for the project.

6. TIMETABLE

A. Listed below are specific and estimated dates and times of events related to this RFP. The events with specific dates must be completed as indicated unless otherwise changed by Dane County. In the event that Dane County finds it necessary to change any of the specific dates and times in the calendar of events listed below, it will do so by issuing an addendum to this RFP. There may or may not be a formal notification issued for changes in the estimated dates and times.

| <u>DATE</u> | <u>EVENT</u> |
|---------------------------|---------------------------------------|
| June 4, 2015 | RFP issued |
| June 16, 2015 | Written inquiries due |
| June 19, 2015 | Last Addendum (if necessary) |
| June 25, 2015 - 2:00 p.m. | Proposals due |
| June 30, 2015 (estimated) | Contract and terms of sale negotiated |
| June 30, 2015 (estimated) | Contract start date |

7. BID / PERFORMANCE GUARANTEES

- A. A bank certified check, cashier’s check or Bid Bond, payable to Dane County equal to five percent (5%) of maximum bid, shall accompany each Proposal as guarantee that if Proposal is accepted, Proposer will execute and submit Performance and Payment Bonds within ten (10) days after being notified of acceptance of Proposal.
- B. Any Proposal, which is not accompanied by bid guarantee, will not be considered.
- C. The selected Proposer will be required to post Performance and Payment Bonds equal to 50% of the total value of the equipment, installation, and startup costs as security for faithful performance of this contract and payment of all persons performing labor on project under this contract and furnishing materials in connection with this contract.
- D. If successful Proposer delivers Certificate of Insurance, and Performance and Payment Bond, bid guarantee check will be returned to Proposer. In case Proposer fails to deliver such insurance and bonds, amount of bid guarantee will be forfeited to County as liquidated damages.

- E. All checks tendered as bid guarantee, except those of three (3) lowest qualified, responsible proposers, will be returned to their makers within three (3) days after Bid Due Date. All such retained checks will be returned immediately upon receipt of Performance and Payment Bond by successful Proposer.

8. ADDITIONAL INFORMATION

- A. Dane County Department of Public Works, Highway & Transportation, 1919 Alliant Energy Center Way, Madison, Wisconsin 53713, will receive your Proposal.
- B. To obtain additional information regarding this project, submit all questions in writing by June 16, 2015 to Mike Rupiper, Special Projects Manager, at rupiper.michael@countyofdane.com. All responses to questions will be posted on the Dane County web site, www.countyofdane.com/pwht/bid/logon.aspx, in the form of Addenda.
- C. Since RFP documents are obtained from the Dane County web site, www.countyofdane.com/pwht/bid/logon.aspx, proposing company is responsible to check back there regularly for Addenda.
- D. All Proposals must be submitted by 2:00 p.m., Thursday, June 25, 2015.
- E. Dane County reserves the right to accept or reject any Proposal submitted. Those who submit proposals agree to do so without recourse against Dane County for either rejection or failure to execute a contract for any reason.
- F. To be considered for this project, the Proposer must meet or exceed the following criteria:
 - 1. Have been in business for a period of not less than three (3) years.
 - 2. Must have successfully completed the design and installation of at least three (3) projects of similar scope and size.
 - 3. Consideration will be given to joint ventures consisting of two or more firms organized for the purpose of furnishing professional services as a single entity, providing the assignment of and provisions for continuity of the various responsibilities within the joint venture are approved by the County, and further providing that either of the individual firms constituting the joint venture meets the eligibility requirements listed above.
- G. Dane County reserves the right to negotiate an Agreement after the successful firm is selected. Selection will be based only on the proposal submitted and any additional information requested. Therefore, the proposals must be complete. Submission of a proposal shall constitute a valid offer, which may be accepted by the County for a period of ninety (90) days following the proposal due date.
- H. Dane County is an Equal Opportunity Employer.
- I. Proposals should not include Federal Excise and Wisconsin Sales Taxes, as Dane County is exempt from payment of such taxes. Sec. State Statute No. 77.54(9a). Wis. Stats. Dane County's CES number is ES 41279.
- J. A purchase order will be used to procure equipment from this RFP. Dane County's Standard Terms and Conditions for Request For Bids/Proposals/Contracts are included in Appendix C for the Proposers information.

Appendix A

Equipment Specifications

SECTION 01 00 00
BASIC REQUIREMENTS

PART 1 GENERAL

1.01 RELATED DOCUMENTS

- A. Conditions of the Contract and portions of Division One of this Project Manual apply to this Section as though repeated herein.

1.02 SECTION SUMMARY

- A. Section Includes:

1. Section Summary
2. Summary of the Work
3. Contractor Use of Premises
4. Applications for Payment
5. Alternates
6. Informational Bids
7. Unit Prices
8. Coordination
9. Cutting and Patching
10. Conferences
11. Progress Meetings
12. Submittal Procedures
13. Proposed Products List
14. Mock-Ups
15. Manufacturers' Instructions
16. Manufacturers' Certificates
17. Quality Assurance / Quality Control of Installation
18. Progress Cleaning
19. Temporary Facilities and Controls
20. Cold Weather Protection
21. Protection of Installed Work
22. Products
23. Transportation, Handling, Storage and Protection
24. Equals and Substitutions
25. Starting Systems
26. Demonstration and Instructions
27. Contract Closeout Procedures
28. Adjusting
29. Operation and Maintenance Data
30. Spare Parts and Maintenance Materials
31. As-Built Drawings and Specifications

1.03 SUMMARY OF THE WORK

- A. Description: Perform the Work as specified and detailed in the Construction Documents. Contractor is to provide construction services for construction and demolition waste recycling equipment for a facility in Madison, Wisconsin.
- B. Work by Owner: Refer to Scope of Work in RFP.

1. Cardboard Baler
 2. Primary electrical feed and electric conduit for processing system.
- C. Permits: Prior to commencement of the Work, Contractor to secure any and all necessary permits for completion of the Work and facility occupancy except those noted to be provided by Owner in Article 5 of the Requested Services and Business Information in RFP.
- D. Examination of Plans, Specification and Site: If in the opinion of the Contractor there are omissions or errors in the plans or specifications, the Contractor shall request clarification from the Dane County special projects manager. In lieu of written clarification by addendum, resolve all conflicts in favor of the greater quantity or better quality.
- 1.04 CONTRACTOR USE OF PREMISES
- A. Limit use of premises to allow work by Contractors or Subcontractors, work by Owner, and access by Owner.
- B. Construction activities with significant noise or temporary disruption of services will be required to be coordinated and scheduled with Owner.
- C. Protect Work from theft, vandalism and unauthorized entry.
- 1.05 APPLICATIONS FOR PAYMENT
- A. Submit two (2) copies of each application on approved Contractors invoice form.
- B. Content and Format: Utilize Schedule of Values for listing items in Application for Payment.
- C. Payment Period: Monthly.
- 1.06 ALTERNATES
- A. Not Applicable.
- 1.07 INFORMATIONAL BIDS
- A. Not applicable.
- 1.08 UNIT PRICES
- A. Not Applicable.
- 1.09 COORDINATION
- A. Coordinate scheduling, submittals, and work of various sections of Specifications to assure efficient and orderly sequence of installation of interdependent construction elements.
- B. Verify utility requirement characteristics of operating equipment are compatible with building utilities.
- C. Coordinate space requirements and installation of mechanical and electrical work that are indicated diagrammatically on Drawings.
- D. Coordinate work by Owner.

- E. The Contractor shall immediately upon entering the site for purpose of beginning work, locate general reference points and take such action as necessary to prevent their destruction. Contractor shall lay out its work and be responsible for all lines, elevations and measurements of the equipment and other work executed under its Contract. Contractor must exercise proper precaution to verify dimensions on the drawings before laying out work and will be held responsible for any error resulting from failure to exercise such precaution.

If property line stakes, benchmarks or datum point are lost, displaced or disturbed through neglect of the Contractor, the Contractor responsible shall pay the cost of restoration.

Contractor shall verify grades, lines, level, locations and dimensions as shown on drawings and report any errors or inconsistencies to the Public Works Project Manager and the Architect/Engineer before commencing work. Starting of work shall imply acceptance of existing conditions.

1.10 CUTTING AND PATCHING

- A. Employ a skilled and experienced installer to perform cutting and patching new work; restore work with new Products.
- B. Submit written request in advance of cutting or altering structural or building enclosure elements.
- C. Fit work tight to adjacent elements. Maintain integrity of wall, ceiling, or floor construction; completely seal voids.
- D. Refinish surfaces to match adjacent finishes.

1.11 CONFERENCES

- A. Dane County Department Public Works, Highway & Transportation will schedule a preconstruction conference after Award of Contract for all affected parties.
- B. When required in individual Specification section, convene a pre-installation conference at project site prior to commencing work of the section.

1.12 PROGRESS MEETINGS

- A. Engineer shall schedule and administer meetings throughout progress of the Work at minimum of two (2) per month.
- B. Engineer shall preside at meetings, record minutes, and distribute copies within three (3) days to those affected by decisions made.

1.13 SUBMITTAL PROCEDURES

- A. Contractor to electronically submit shop drawings for each submission. Printed copies to be submitted upon request.
- B. The Contractor shall submit at the pre-construction meeting a list of all known submittals required for the project.
- C. Submittal form to identify Project, Contractor, Subcontractor or supplier; pertinent Construction Documents references, and submittal number. Submittals shall be organized by specification section, combined submittals will not be accepted. Contractor shall coordinate submittals for

related parts of the Work so processing will not be delayed because of need to review submittals concurrently for coordination.

- D. Identify variations from Construction Documents and Product or system limitations that may be detrimental to successful performance of completing the Work.
- E. Include written warranties in all submittals per technical specification section. Include written warranties in Operation and Maintenance manual.
- F. Product Data to identify applicable products, models, options, and other data. Supplement manufacturer's standard data to provide information unique to this Project.
- G. Revise and resubmit submittals as required until receiving final approval; identify all changes made since previous submittal.

1.14 PROPOSED PRODUCTS LIST

- A. Within fifteen (15) days after date of Award of Contract, submit complete list of major Products proposed for use, with name of manufacturer, trade name, and model number of each Product.

1.15 MOCK-UP

- A. Notify Engineer 7 days in advance of the dates and times when mock-up will be prepared. Incorporate only previously submitted and approved materials.
- B. Refer to individual specification sections for additional mock-up requirements. Mock-up to reflect details within the Contract Documents.
- C. Approval of mock-ups does not constitute approval of deviations from the Contract Documents contained in the mock-ups unless Engineer specifically approves such deviations in writing.

1.16 MANUFACTURERS' INSTRUCTIONS

- A. When specified in individual Specification sections, submit manufacturers' printed instructions for delivery, storage, assembly, installation, start-up, adjusting, and finishing, in quantities specified for Product Data.

1.17 MANUFACTURERS' CERTIFICATES

- A. When specified in individual Specification sections, submit manufacturers' certificate to Public Works Project Engineer and Engineer for review, in quantities specified for Product Data.
- B. Indicate material or Product conforms to or exceeds specified requirements. Submit supporting reference data, affidavits, and certifications as appropriate.

1.18 QUALITY ASSURANCE / QUALITY CONTROL OF INSTALLATION

- A. Monitor quality control over suppliers, manufacturers, Products, services, site conditions, and workmanship, to produce work of specified quality.
- B. Comply fully with manufacturers' instructions.

- C. Comply with specified standards as minimum quality for the Work except when more stringent tolerances, codes, or specified requirements indicate higher standards or more precise workmanship.

1.19 PROGRESS CLEANING

- A. Maintain areas free of waste materials, debris, and rubbish. Maintain site in clean and orderly condition.
- B. Remove debris and rubbish from pipe chases, crawl spaces and other remote or close spaces prior to enclosing spaces.
- C. Broom and vacuum clean interior areas prior to start of surface finishing, and continue cleaning to eliminate dust, debris and protect finished surfaces.

1.20 TEMPORARY FACILITIES AND CONTROLS

- A. Temporary facilities and controls including temporary office, toilets, water service, electricity, and lighting will be provided by C&D building general contractor.
- B. Traffic Regulation: Post signage and provide traffic, cones, drums, flares, lights and trained flag persons as approved by authority having jurisdiction.

Consult with Dane County Public Works Project Manager and authority having jurisdiction to establish public thoroughfares to be used for haul routes and site access. Remove equipment at Substantial Completion and restore site.

- C. Pollution Control: Provide methods, means and facilities to prevent contamination of soil, water, and atmosphere from discharge of noxious, toxic substances, and pollutants produced by construction operations. Comply with pollution and environmental control requirements of authorities having jurisdiction.

1.21 COLD WEATHER PROTECTION

- A. All heating and protective covering, required to protect the work from injury due to freezing and moisture during the construction period and prior to enclosure of the building, shall be classed as COLD WEATHER PROTECTION. Such protection shall be provided and paid for by the Contractor.
- B. Provide and pay for heating devices and heat as need to maintain specified conditions for construction operations. Heat required to protect materials from injury due to freezing during the construction period prior to enclosure, shall be provided by means of portable heating units intended for this purpose. All heating units must be approved types. Proper ventilation must be provided. The use of temporary units whose product of combustion will damage fresh concrete, mortar or other building materials, will not be allowed. Use of coke or oil salamanders is prohibited. Heating units and the area surrounding the units shall be kept in a clean and safe condition.
- C. Equipment installed as a part of this project is not allowed to be used for building conditioning prior to Commissioning or Substantial Completion as determined by the Public Works Project Manager.

1.22 PROTECTION OF INSTALLED WORK

- A. Protect installed work and provide special protection where specified in individual Specification sections.

1.23 PRODUCTS

- A. Products: Means new material, machinery, components, equipment, fixtures, and systems forming the Work, but does not include machinery and equipment used for preparation, fabrication, conveying and erection of the Work. Products may also include existing materials or components specifically identified for reuse.
- B. Do not use materials and equipment removed from existing premises, except as specifically identified or allowed by Construction Documents.

1.24 TRANSPORTATION, HANDLING, STORAGE AND PROTECTION

- A. Transport, handle, store and protect Products in accordance with manufacturer's instructions.

1.25 EQUALS AND SUBSTITUTIONS

- A. Where definite material is specified, it is not intention to discriminate against "equal" product made by another manufacturer. Intention is to set definite standard of material quality. Material, equipment, or processes offered for use as an 'Equal' or 'Substitution' may be proposed by the Contractor in writing. Contractor shall submit said materials specifications electronically for Architect/Engineer and Public Works Project Manager approval prior to Bid Opening. Public Works Project Manager will provide decision on requested equal or substitution request prior to Bid Opening for submittals received at least ten (10) days prior to Bid Opening. Decisions on submittals made later than (10) days prior to Bid Opening may not be made prior to Bid Opening.
- B. Products and materials that are not specified, but have been approved for use by the Architect/Engineer and Public Works Project Manager shall be identified in addenda to all bidding contractors.
- C. Document each request with complete data substantiating compliance of proposed Substitution with Construction Documents.

1.26 STARTING SYSTEMS

- A. Provide written notification to Architect/Engineer and Public Works Project Manager prior to start-up of each equipment item or system.
- B. Ensure that each piece of equipment or system is ready for operation.
- C. Execute start-up under supervision of responsible persons in accordance with manufacturers' instructions.
- D. Submit written report that equipment or system has been properly installed and is functioning correctly.

1.27 DEMONSTRATION AND INSTRUCTIONS

- A. Demonstrate operation and maintenance of Products to Owner's personnel prior to date of final inspection.

- B. Demonstrate start-up, operation, control, adjustment, trouble-shooting, servicing, maintenance, and shutdown of each item of equipment at agreed-upon times, at designated location.

1.28 CONTRACT CLOSEOUT PROCEDURES

- A. Submit written certification that Construction Documents have been reviewed, the Work has been inspected, and the Work is complete in accordance with Construction Documents and ready for Architect/Engineer observation and Public Works Project Manager's inspection. Submit a list of any items that are not complete for Architect/Engineer review prior to scheduling substantial and final completion site visits.
- B. Execute final cleaning prior to final inspection.
- C. Submit final Application for Payment identifying total adjusted Contract Sum / Price, previous payments, and amount remaining due.

1.29 ADJUSTING

- A. Adjust operating Products and equipment to ensure smooth and unhindered operation.

1.30 OPERATION AND MAINTENANCE DATA

- A. Assemble a complete set of operation and maintenance data and warranties for all products and mechanical and electrical equipment supplied and installed in project. Submit (2) printed copies organized in 3 ring binders by specification section and electronically in PDF format with bookmarks by specification section. Identify with project name and 'Operation and Maintenance Manual'.

1.31 SPARE PARTS AND MAINTENANCE MATERIALS

- A. Provide Products, spare parts, maintenance and extra materials in quantities specified in individual Specification Sections.
- B. Deliver to the Work site and place in location as directed.

1.32 AS-BUILT DRAWINGS AND SPECIFICATIONS

- A. Contractor-produced Drawings and Specifications shall remain property of Contractor whether Project for which they are made is executed or not. Contractor shall furnish Public Works Project Manager with original tracings of drawings and prints of specifications in reproducible format, one set of Drawings and Specifications and one set of as-builts drawings in AutoCAD 2010 (or lower) format on CD.

PART 2 PRODUCTS

2.01 Not Used.

PART 3 EXECUTION

3.01 Not Used.

END OF SECTION

SECTION 11 90 00

C&D WASTE PROCESSING SYSTEM

PART 1 GENERAL

1.01 RELATED DOCUMENTS

Conditions of the Contract and portions of Division One of this Project Manual apply to this Section as though repeated herein.

1.02 DESCRIPTION OF THE WORK

The construction and demolition (C&D) waste processing system shall be a new, pre-engineered system comprised of proven, integrated components and controls, including structures and machinery that are specifically designed to handle typical urban and commercial C&D wastes.

The minimum capacity of the system, at the initial in-feed equipment, shall be approximately 350 tons per day using an average waste weight of 400 pounds per cubic yard, over a 10-hour operating day (i.e., 175 cubic yards per hour).

A single, qualified Contractor shall be responsible for providing the complete C&D processing system, however, the system itself may be composed of equipment and structures provided or manufactured by multiple qualified vendors. The meaning of the word "providing" shall be understood to include overall responsibility to the Owner for: final design, construction layout, shop drawings, component fabrication, shipping, assembly/installation, quality assurance, start-up/shake-down, system warranty, O&M Manual, and operator training.

1.03 SYSTEM REQUIREMENTS

The C&D waste processing system shall be designed to provide maximum opportunity to separate the waste stream into several specific material types, as indicated on the Drawings, using automated and manually-assisted equipment and work stations, integrated with proven personnel safety features in accordance with OSHA regulations, the City of Madison, Wisconsin Building Code, and applicable ANSI Standards for Facility Safety.

The Contractor shall provide all electrical circuit protection and shut-off/alarm devices, control panels, and power and instrumentation wiring circuitry necessary to operate the entire system in an integrated manner and to interface with the power supply. The operation of the system shall be provided by a central computerized screen that will allow automatic and manual over-ride of the system. Owner will provide the primary electrical feed for the processing system.

The C&D waste processing system shall be essentially composed of two main processing lines (A-Line and B-Line) and the following major components that include, but are not limited to (Drawing Equipment No. noted in parentheses):

A-Line

- Primary Finger Screen (1)
- Slider Bed Conveyor (Primary Finger Screen Overs) (2)
- Troughing Idler Conveyor (Primary Finger Screen Unders) (11)
- Slider Bed Conveyor (Picking A-Line) (3)

B-Line

- Ferrous Magnet (4)
- Slider Bed Conveyor (Secondary Finger Screen Infeed) (5)

- Secondary Finger Screen (6)
- Destoner / Air Knife (7)
- Slider Bed Conveyors (De-stoner/Air Knife Outfeed) (8)
- Slider Bed Conveyor Picking B-Line (9)
- Troughing Idler Conveyor (Small Residuals Bunker) (10)

Other

- Aggregate Conveyor (14)
- Slider Bed Conveyor (Aggregate on Platform) (15)
- Slider Bed Conveyor (Fines Bunker Infeed) (12)
- De-stoner/Air Knife Dust Collector/Filter (13)
- Cardboard Baler (19) (Provided and Installed by Owner)
- Elevated Picking Line Platform and Drop Chutes
- Access Ladders to various pieces of equipment at common material jam points
- Conveyor Transition Chutes/Guards, as needed
- Integrated Electrical Controls with HMI screen for graphics-based visualization of the control and monitoring system
- Safety /vibration, thermal and current overload Alarms/Shut-down Features

All equipment sizing and design criteria noted are estimated and subject to change. The Contractor shall be responsible for the exact equipment sizing, mechanical and electrical design capacity of all equipment. Equipment sizing and design to be based on the design throughput at the head of the system provided by Owner, including any adjustment or re-design to electrical wire sizing and control devices for their processing equipment.

The Contractor is responsible for confirming the fully loaded weight of the equipment, providing adequate load supports, structural support and bracing, and verifying that the system will not overload the concrete floors.

The Drawings represent the overall intent of the Owner for this system, however, they may not indicate every detail necessary or required of the waste processing system. The Contractor shall include all hardware, devices, and equipment either necessary or required, whether indicated on the plans or not, so that the system is complete, adequate in capacity, meets the aforementioned Codes and standards, and is fully operational before turning it over to the Owner.

The Owner may entertain modifications to the system in a Contractor's proposal that may result in minor changes in alignment, location, and/or orientation of the system components or changes in equipment size to meet required capacity, however, these changes must be consistent with all of the other proposed building facility modifications.

1.04 WORK INCLUDED

- A. The work included under this section consists of furnishing and installing a new C&D waste processing system. The system shall include modifications to the existing facility, including electrical power connection, and furnishing and installation of the C&D infrastructure, sorting equipment and other related equipment, which should be fully tested and in operating condition as shown in the Contract Documents.
- B. It is the Owner's intent to obtain a complete system. The Contractor shall provide any item at no extra cost that is necessary to provide a complete and operable system as intended by the Drawings, whether or not that item, equipment or feature is shown on the Drawings or described in the Specifications.

1.05 QUALITY ASSURANCE

- A. Equipment Responsibility: The conveyors and primary sorting equipment shall be supplied by the Contractor. The Contractor shall have experience in providing equipment for C&D waste processing facilities.
- B. Factory tests: An operational test shall be conducted and all equipment shall be calibrated and tested to assure proper operation. Documentation of tests shall be provided to the Engineer and Owner.
- C. Each submittal for equipment and system components shall be accompanied by an "Equipment Warranty and Certification Form". The form shall be duly executed by an authorized principal of the manufacturer warranting and certifying that the equipment and system components proposed meets or exceeds the specifications, is suitable for its intended purpose and will provide satisfactory performance at the design criteria/capacity specified. In the event that the manufacturer is not the supplier, an authorized principal of the supplier shall also execute the equipment warranty and certification form.
- D. All electrical or electronic devices shall be U.L. listed or Factory Mutual listed.

1.06 SUBMITTALS

- A. Contractor shall provide shop drawings prepared by the manufacturer and submitted to the Engineer for review prior to the manufacture of the proposed equipment. A copy of the manufacturer's warranty shall be included with each submittal. The Contractor shall provide the required number of submittals at no extra cost to the Owner. In addition, the shop drawings shall include the following:
 - 1. Comprehensive two dimensional CAD drawing of the equipment exterior as viewed from the front and side. Include complete control layout showing location of component parts as well as full electrical schematic of control operation.
- B. Operating Instruction: For the equipment, conveyors, and controls under this section, Contractor shall submit operation and maintenance manuals. At a minimum these manuals shall include:
 - 1. General equipment function, description, normal and limiting operating characteristics.
 - 2. Installation instructions.
 - 3. Operation instructions, start up procedure, emergency and normal shutdown, and restart procedures.
 - 4. Troubleshooting guide.
 - 5. Assembly and wiring diagrams.
 - 6. List of spare parts on-hand.
- C. Factory Performance Test Data: A qualified technician from the factory shall be provided for three continuous days to instruct representatives of the Owner and the Engineer on proper operation and maintenance. With the permission of the Owner, this work may be conducted in conjunction with the inspection of the installation and system start-up. If during start-up there is an equipment failure due to the manufacturer's design or fabrication of the equipment, additional services shall be provided at no additional cost to the Owner. System start-up shall be completed by a factory technician. This technician should be a direct employee of the manufacturer who has had first hand dealings with the equipment through its production at the factory.

Certifications: Contractor shall furnish the Owner and Engineer with a written certification signed by the manufacturer that the equipment has been properly installed. The form should indicate that all equipment has been operated without fault and that satisfactory operation and design capacity has been obtained.

- D. Approved Equal: For alternative equipment to be approved equal the Contractor must submit any alternative equipment to the Engineer prior to the bid. To be considered equal the Contractor must demonstrate that; they have a successful track record of use of this piece of equipment in a similar setting and waste type, the alternative equipment has equivalent operating capacity, similar proposed dimensions and is compatible with existing and proposed equipment and conveyors at the facility.

1.07 DELIVERY, STORAGE, AND HANDLING

- A. Deliver a complete system to include all parts listed in submittal approved by Engineer.
- B. Store in a weather-tight building or suitable covering to protect against damage of any nature.
- C. Handle during delivery, storage and installation in a manner to prevent damage of any nature.

1.08 WARRANTY AND GUARANTEES

- A. The Contractor shall provide all warranty services against defects in materials and workmanship for a minimum of one year from the date of written acceptance of the system by the Owner to the effect that any defective or damaged equipment shall be repaired or replaced without extra cost or obligation to the Owner.

PART 2 PRODUCTS

2.01 PRIMARY FINGER SCREEN

- A. The proposed primary finger screen shall have a minimum design capacity of 175 cubic yards per hour.
- B. Provide deflector plates to facilitate top loading and containment of C&D waste.
- C. The primary finger screen shall be manufactured by General Kinematics or approved equal.

2.02 SECONDARY FINGER SCREEN

- A. The proposed secondary finger screen shall have a minimum design capacity of 100 cubic yards per hour.
- B. The secondary finger screen shall be manufactured by General Kinematics or approved equal.

2.03 FERROUS MAGNET

- A. Overhead Magnetic Separator Requirements
 - 1. Overhead magnetic separator shall be DINGS Model 55T or approved equal.
 - 2. TEFC 5 HP, 230/460-3-60 AC motor.
- B. Rectifier Requirements
 - 1. The rectifier shall be a DINGS 8KW silicon diode rectifier or approved equal.
 - 2. The Rectifier for the magnetic separator shall be provided in a NEMA 12 enclosure.
 - 3. AC input 460 volts, 3PH, 60HZ.
 - 4. DC output 115 volts, 5000 watts.
 - 5. Three phase maintenance free solid state rectifier bridge.

2.04 DESTONER/AIR KNIFE

- A. General Kinematics Model DS-F 60 X 19.5 Vibratory Single Knife De-Stoner / Classifier or approved equal.
- B. Inlet Air Plenum
 - 1. Include required air distribution boxes, complete with slide gate type dampers and flexible connections with band clamps, blower, and blower motor.

2.05 COLLECTOR AND FILTER

- A. The destoner/ air knife shall be equipped with an integrated dust capture and filter system, minimum flow rate of 12,000 CFM, including the centrifugal fan, with an impeller designed to work in the heavy dust and debris environment expected from the air knife discharge with design to minimize entanglement with strings and fibrous material, access clean-out panels, filter panels and filters, TEFC motor, belt-drive motor to fan arrangement, all ductwork, capture hood with removable panels for cleaning and access, return air manifold, and metal framed support structure, manufactured by General-Kinematics, Inc. Provide four spare air filter elements.

2.06 CONVEYORS

- A. This equipment has the following characteristics:
 - 1. Design: Slider Bed
 - 2. Materials: Commercial mixed C&D materials and products, including; small and large stones up to approximately 12 inches, concrete pieces, rubber, brick, sand, glass, fiberglass, asphalt, metals, wood, gypsum, plastics, paper, vinyl, ceramic, etc. Typical feedstock products include, but are not limited to; pipe, dimensional lumber, consumer products, boxes, hose, pallets, shrink wrap, buckets, conduit and wiring, wallboard, tiles, mastic/glues, shingles, carpeting, rebar, furniture, insulation, electrical devices, ductwork, metal studs, hardware, doors, windows, and lighting.
 - 3. Speed: Variable speed control suited to the specific equipment, capacity, location, and if paired with manual picking stations.
 - 4. Length: Varies
 - 5. Width: Varies
 - 6. Motor shall be Emerson or Baldor Severe Duty Motor, 1800 RPM, 230/460V, 60Hz, 3PH, TEFC, or approved equal.
 - 7. Reducer shall be Dodge Shaft Mount Speed Reducer or approved equal.
 - 8. Shafting shall be C-1045 cold rolled precision.
 - 9. Bearings shall be Dodge, Sealmaster or SKF – IP Pillow Block or approved equal.
 - 10. Belting shall be black heavy duty belting 3Ply-220PIW, 2/16” x BB or approved equal.
 - 11. Fastener System shall be FLEXCO R5 Megaloy Fasteners or approved equal.
 - 12. Pulleys: Head shall be heavy duty drum pulley crown faced and lagged 3/8” thick diamond pattern complete with XT hubs and bushings. Tail shall be heavy duty wing pulley complete with XT hubs and bushings.
 - 13. 1/4” sides and frame.
 - 14. Return Idlers shall be CEMS D-5” to 7” diameter channel inset return steel disc idler or approved equal.
 - 15. Wide slot adjustable screw type take up frames.
 - 16. Safety Guards: all rotating parts guarded in accordance with OSHA regulations.
 - 17. Supports shall be bolted structural steel members braced and mechanically anchored to concrete floor or bolted on steel structure.
 - 18. Provide chevrons or equivalent slip prevention on all inclined conveyor belts.

PART 3 EXECUTION

3.01 GENERAL

- A. All materials and equipment shall be installed as shown on the Drawings and as recommended by the manufacturer.

3.02 INSPECTION AND TESTING

- A. Field supervisor: A factory-trained representative shall inspect the completed installation, make necessary adjustments and instruct Owner and Engineer in the proper care and operation of the equipment, prior to the final acceptance of the C&D sorting system.
- B. Field Test: When the system is complete and ready for operation, then the system shall be inspected and tested for compliance to the contract documents. Test of equipment shall be made by the Contractor in the presence of the Engineer and the Owner. Owner will supply representative waste for the duration of the test, which shall be a minimum of 2 hours of continuous run time with no stoppages due to a system malfunction or material jam. The equipment tests shall include, but will not be limited to the following:
 - 1. The screens and conveyors shall be tested to operate at design capacity.
 - 2. Electrical: Readings shall be made of the voltage and amperage draw and recorded on the manufacturer's start-up form.
 - 3. Controls: Control primary elements shall be tested to determine satisfactory performance and alarm functions, and emergency stop functions will also be tested.
 - 4. Inspection: An inspection of all mechanical and electrical equipment, controls, brackets, mountings, seals, conduit, and component features shall be made while the system is being tested to determine performance and compliance with design requirements and the specification.
 - 5. Repairs, adjustments and replacement: The Contractor shall make any and all necessary repairs, adjustments and replace any component parts until performance has been demonstrated to the satisfaction of the Owner and Engineer. The Contractor shall bear the cost of any repair, adjustment and replacement.

END OF SECTION

SECTION 11 90 01

REQUIREMENTS FOR PROPOSING USED EQUIPMENT OR SYSTEM (C&D WASTE PROCESSING SYSTEM)

PART 1 GENERAL

1.01 DESCRIPTION OF THE WORK

A used, not new, but properly reconditioned piece of equipment or an entire system may be acceptable in the Contractor's bid. Any piece of equipment, whether it is electrical, mechanical, or structural, is required to be reconditioned to a condition that is "like new". The minimum requirements to be considered "like new" status include:

- A. Must be less than 3 years old, with this age starting from when the equipment was delivered to the original owner.
- B. Have only one prior owner.
- C. The original manufacturer shall have a permanent service representative in the U.S. or Canada and have a U.S. or Canadian- based parts depot, or can demonstrate that parts outside the U.S. can be delivered to the site within 72 hours.
- D. Equipment originally delivered, but possibly never operated or not taken out of original packaging, shall be considered used, and shall meet the reconditioning requirements.
- E. All equipment must have the original (or a copy of) bill of purchase, and a written record of any maintenance.
- F. The Contractor must identify and list in their bid all reconditioned equipment, whether mechanical, electrical or structural.
- G. Any piece of electrical equipment or equipment with electrical wiring shall have been used indoors only.
- H. No known operational problems, including fire, explosion, lightning strike, over- current, over-heating, or rain, snow or sleet damage or flooding.
- I. The equipment must be considered by the Owner as "or equal" to any of the new equipment named in the project bid documents.

PART 2 PRODUCTS

2.01 NOT USED

PART 3 EXECUTION

3.01 GENERAL

- A. The following elements must be addressed and conducted:
 - 1. All electrical wiring and conduit and junction boxes replaced with new.

2. All electrical controls replaced with new, including cabinets, starters, relays, wiring, switches, terminal blocks, grounding lugs, bus bars, alarm, telecommunication devices, signal, operating, and warning lights. If more than 25% of the box surface has rust or corrosion, it must be replaced
3. Electrical control boxes shall meet NEMA 4 requirements minimum.
4. All electrical controls must meet the National Electric Code.
5. All electrical devices must have the UL label or the Factory Mutual label.
6. All conveyor belts and bushings replaced with new, tensioned and aligned.
7. All broken pieces repaired or replaced.
8. All motor / pulley belts replaced and aligned.
9. All bent, out of level or out of plumb pieces shall be straightened and made level or plumb.
10. All visible rust or corrosion removed, and metal polished, primed and painted if this was the original finish, or otherwise sealed against further corrosion.
11. All bearings removed, cleaned and re-greased, or replaced if any signs of overheating, pitting or corrosion.
12. All exterior metal have all dents removed and all cracked metals re welded.
13. All broken welds re-welded.
14. All grease and lubrication points replenished with new fluids and materials.
15. Strength of magnets proof tested and replaced if it does not meet manufacturer's original specification. Corroded magnets will not be acceptable.
16. All exterior metal, blast cleaned, re-primed and repainted with one coat each of compatible polyurethane paint.
17. All chain drives removed including axles, disassembled, cleaned, re-greased and realigned. Any damaged or corroded chains or pins shall be replaced with new.
18. All motors disassembled, cleaned, any broken wiring and defective soldering and wiring terminals replaced. Motor casings repainted inside and out. Motor must be load tested and a certificate attesting to passing this test provided. Tests must include full load amps, short circuit amps, speed, frequency, voltage and meet manufacturer's original specification.

3.02 SUBMITTALS AND WARRANTIES

- A. The reconditioned equipment and system shall meet all inspections and start-up and shakedown tests specified in the project specifications for the new equipment and system.
- B. Before delivering equipment, provide proof that the reconditioning was completed, including:
 1. A valid invoice for materials, labor and testing in the reconditioning of each piece of electrical, structural, and mechanical equipment

2. A warranty signed by the Contractor for each piece of equipment, mechanical and electrical, that covers replacement of defective or broken materials and equipment for one year from acceptance by the Owner. The equipment shall be repaired or replaced at no extra cost to the Owner.
 3. The cost of reconditioning and/ or to fit any equipment into the process or the building, including disassembly at a remote site, all transport costs and license, all permit fees, and reassembly at the project site shall be included in the bid.
- C. No scheduling extensions will be allowed for reconditioning equipment. Equipment shall be installed within the agreed-to schedule or the schedule in the project specifications.

END OF SECTION

SECTION 26 05 00

COMMON WORK RESULTS FOR ELECTRICAL

PART 1 GENERAL

1.01 RELATED DOCUMENTS

- A. Conditions of the Contract and portions of Division One of this Project Manual apply to this Section as though repeated herein.
- B. Refer to C&D Materials Recovery Facility Division 26 bid documents (Bid No. 315011) for general wiring product and installation method requirements. All applicable requirements of that project apply to this section.

1.02 DESCRIPTION

- A. Section includes providing, installing electric and appurtenances from the electrical room to the proposed equipment, as well as system controls and program logic as shown on the Drawings.
- B. Main motor control center to be provided by this contractor and installed by Electrical Contractor for the Bid No. 315011 contract. All wiring from the motor control center to proposed equipment shall be included in the Bid No. 315010 contract.

1.03 SUBMITTALS

- A. Submit in accord with the General Conditions of the Contract.
- B. Submit shop drawings of all electric equipment.

PART 2 PRODUCTS

2.01 MOTOR CONTROL CENTER

- A. All electrical motor control centers must be wired by UL Rated shop and provide a self-certification sticker. Main motor control center must maintain a minimum Interrupting Capacity of 65,000 AIC. The main electrical panel is to accept 460VAC, 3Ph/60Hz.

2.02 PRIMARY DISCONNECT

- A. Primary disconnect to be mounted in Sequestr® box or a wall mounted fused disconnect may be provided. Mechanical or electrical door locks are to be integrated into main panel to prevent opening electrical cabinet door(s) when main disconnect is on.

2.03 LOCAL DISCONNECTS

- A. To be provided and installed as required by NEC 430.102.

2.04 ELECTRICAL ENCLOSURES

- A. All electrical enclosures to be Rittal, Hoffman, or Similar in RAL7035 (light grey) finish with NEMA12 Rating (dust tight). Main Electrical panel to have foot or Plinth height of no less than 8".

2.05 FUSING

- A. Primary Fuses to be Class J. Transformer Primary and Secondary to be fused. 24V Power Supply, 120VAC Programming Outlet to be fused. Contractor to provide a minimum of one complete set of spare fuses. Programming port to be fused or breaker.

2.06 CONTROL – PLC

- A. Allen Bradley – Compact Logix or approved equal.

2.07 OPERATOR TOWER – HMI / CONTROL

- A. HMI to be Allen Bradley 15” PanelView or approved equal. HMI to be mounted in console style enclosure for remote mounting in operator tower. Other push buttons on console to include Estop, Start, Stop, Reset Push buttons, (3) Potentiometers, and maintained pushbutton. Console incoming power to be 120VAC Single Phase (fused) with 24VDC Power supply located inside the console. Communications to PLC (remotely mounted in Main Electrical Panel) to be Ethernet IP.

2.08 VARIABLE FREQUENCY DRIVES (VFDs)

- A. Variable Frequency Drives shall be provided for (4) Conveyors. All VFDs to be “Heavy Duty” rated for specified horse power. All VFDs to be ABB ACS355 or approved equal w/ Advanced Keypad. Keypads are to be remote mounted on front door of main electrical enclosure.
- B. Preliminary Conveyor HP Sizes (Drawing equipment numbers in parentheses):
 - 1. 15 HP Slider Bed Conveyor (Primary Finger Screen Overs) (2)
 - 2. 15 HP Slider Bed Conveyor Picking A-Line (3)
 - 3. 10 HP Slider Conveyor Picking B-Line (9)
 - 4. 7.5 HP Slider Bed Conveyor (Aggregate on Platform) (15)
- C. All VFD’s to have drive fault contact to be wired and programmed to PLC for fault identification status on HMI. All VFDs to be speed controlled through analog and/or Ethernet IP. Speeds are to be set through two options: HMI control panel OR A and B Line potentiometers located on console. Drive enable to be hardwired to PLC through 24VDC I/O.

2.09 MANUAL MOTOR STARTERS

- A. Preliminary Manual Motor starter (Drawing equipment numbers in parentheses):
 - 1. 50 HP Primary Finger Screen (1)
 - 2. 10 HP Slider Bed Conveyor (Secondary Finger Screen Infeed) (5)
 - 3. 50 HP Secondary Finger Screen (6)
 - 4. 5 HP Troughing Idler Conveyor (Small Residuals Bunker) (10)
 - 5. 7.5 HP Troughing Idler Conveyor (Primary Finger Screen Unders) (11)
 - 6. 10 HP Slider Bed Conveyor (De-stoner / Air Knife Outfeed) (8)
 - 7. 10 HP Slider Bed Conveyor Fines Bunker Infeed (12)
 - 8. 5 HP Ferrous Magnet (4)
 - 9. 15 HP De-stoner / Air Knife (7)
 - 10. 10 HP Aggregate Conveyor (14)
- D. All motor starters to be wired and programmed to PLC for fault identification status on HMI.

2.010 SOFTSTARTER

- A. A softstart or VFD with fault indication shall be provided for the 30 HP De-stoner Blower (Drawing equipment number 13).

2.011 SAFETY CIRCUIT

- A. An Estop safety controller and associated circuit shall be provided to isolate power among all VFDs and starters. Contractor shall provide (2) Rope Pull Switches, (5) Enclosed Estop Switches, and (1) Estop button for the console. All safety rated devices should have a status circuit to indicate fault location. Each safety switch fault circuit shall be independently monitored to provide notification on HMI if signaled. Rope pulls and enclosed Estop switches to be wired and installed by others.

2.012 AUDIBLE ALARMS

- A. Contractor to provide a PLC alarm output to indicate machine stops, starts, and faults. Three unique sounds or pulses shall be outputted to differentiate between the three conditions. Four (4) sets of field wiring points shall be provided and (4) Rotating Beacon + Alarm shall be provided. Selected Alarm shall have a rotating red light and a minimum of 105 dB at 1 Meter audible alarm with minimum of an IP55 rating. Wall mounting brackets shall be included with all alarms.

2.013 MISCELLANEOUS HARDWARE

- A. A 120VAC receptacle and Ethernet programming port to be mounted on the exterior of the main electrical panel.

2.014 DOCUMENTATION

- A. Contractor to supply full wiring diagrams.

2.015 SOFTWARE

- A. A Dell 5000 Series 15" laptop or approved equal loaded with a licensed copy of all applicable software, associated PLC / HMI programs (unrestricted access), and associated programming cables must be provided. Owner will retain full ownership of the program written.

2.016 PROGRAM OVERVIEW

A. Normal Operation

1. Operator in operator tower presses start button.
2. Rotating red beacon and start audible alarms sound.
3. Conveyors start in reverse order with slight delay between conveyors.
4. Stop button is pushed and all equipment stops.
5. Rotating red beacon and stop audible alarms sound.

B. Settings (Drawing equipment numbers in parentheses)

1. Primary Finger Screen (1) speed set on 1st potentiometer setting.
2. Slider Bed Conveyor (Primary Finger Screen Overs) (2) and Slider Bed Conveyor Picking A-Line (3) set on 2nd potentiometer setting.
3. Slider Bed Conveyor Picking B-Line (9) speed set on 3rd potentiometer setting.
4. When maintained push button is enabled, the Slider Bed Conveyor (Primary Finger Screen Overs) (2) goes to zero speed when "Dead man" switch is disabled.

5. When maintained push button is disabled, the Slider Bed Conveyor (Primary Finger Screen Overs) (2) runs at 2nd potentiometer speed with the “dead man” switch disabled.

C. Maintenance Features

1. All motors shall have a jog feature on HMI to allow to independently control each motor (ON / OFF only).
2. HMI to indicate which Estop is pressed through 3rd channel on switch.
3. HMI to indicate specific VFD fault or Manual Motor Starter Trip.
4. HMI to display hour meter to track total machine processing hours.

PART 3 EXECUTION

3.01 COORDINATION

- A. Coordinate all electrical requirements with the Bid No. 315012 Electrical Contractor prior to equipment delivery. Provide approved shop drawings at appropriate times to facilitate construction schedule.

3.02 PROGRAMMING / STARTUP

- A. Provide a fully debugged program for control system and (2) days of onsite initial startup assistance and (1) additional day onsite for small program modifications.

END OF SECTION

Appendix B

Equipment Plans

Plot drawings on 30" x 42" (ARCH E1) paper for correct scale.

CONSTRUCTION & DEMOLITION WASTE RECYCLING FACILITY EQUIPMENT BID DOCUMENTS - BID NO. 315033 7102 U.S. HIGHWAY 12/18 MADISON, WISCONSIN

SCS ENGINEERS
 2830 DAIRY DRIVE MADISON, WI 53718-6751
 PHONE: (608) 224-2830

**CONSTRUCTION AND
 DEMOLITION WASTE
 RECYCLING FACILITY
 7102 US HWY 12/18
 MADISON, WISCONSIN**

DANE COUNTY DEPARTMENT OF
 PUBLIC WORKS
 SOLID WASTE DIVISION
 1919 ALLIANT ENERGY CENTER WAY
 MADISON, WI 53713

PROCESS AND CIVIL ENGINEER:
 SCS ENGINEERS
 2830 DAIRY DRIVE
 MADISON, WI 53718-6751
 (608) 224-2830

ARCHITECT:
 DORSCHNER ASSOCIATES, INC.
 849 E. WASHINGTON AVE., SUITE 112
 MADISON, WI 53703

STRUCTURAL ENGINEER:
 PIERCE ENGINEERS, INC.
 10 WEST MIFFLIN ST., SUITE 205
 MADISON, WI 53703

**MECHANICAL, ELECTRIC, PLUMBING
 DESIGN:**
 JDR ENGINEERING, INC.
 5525 NOBEL DRIVE, SUITE 110
 MADISON, WI 53711

PREPARED FOR: DANE COUNTY DEPARTMENT OF PUBLIC WORKS, HIGHWAY AND TRANSPORTATION
 PUBLIC WORKS SOLID WASTE DIVISION
 1919 ALLIANT ENERGY CENTER WAY
 MADISON, WISCONSIN

PREPARED BY: SCS ENGINEERS
 MADISON, WISCONSIN

DATE: JUNE 2015

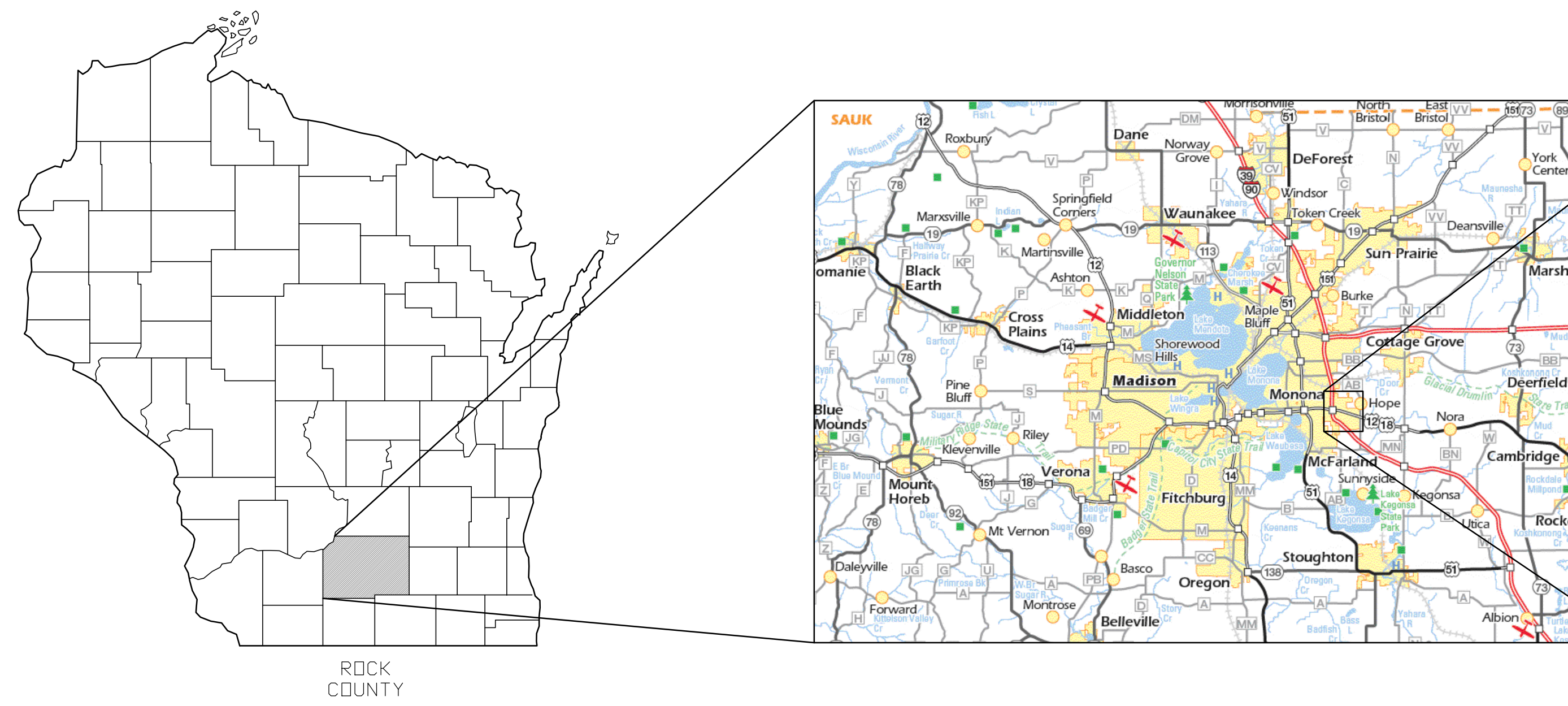

WISCONSIN

VICINITY
 LOCATOR MAP

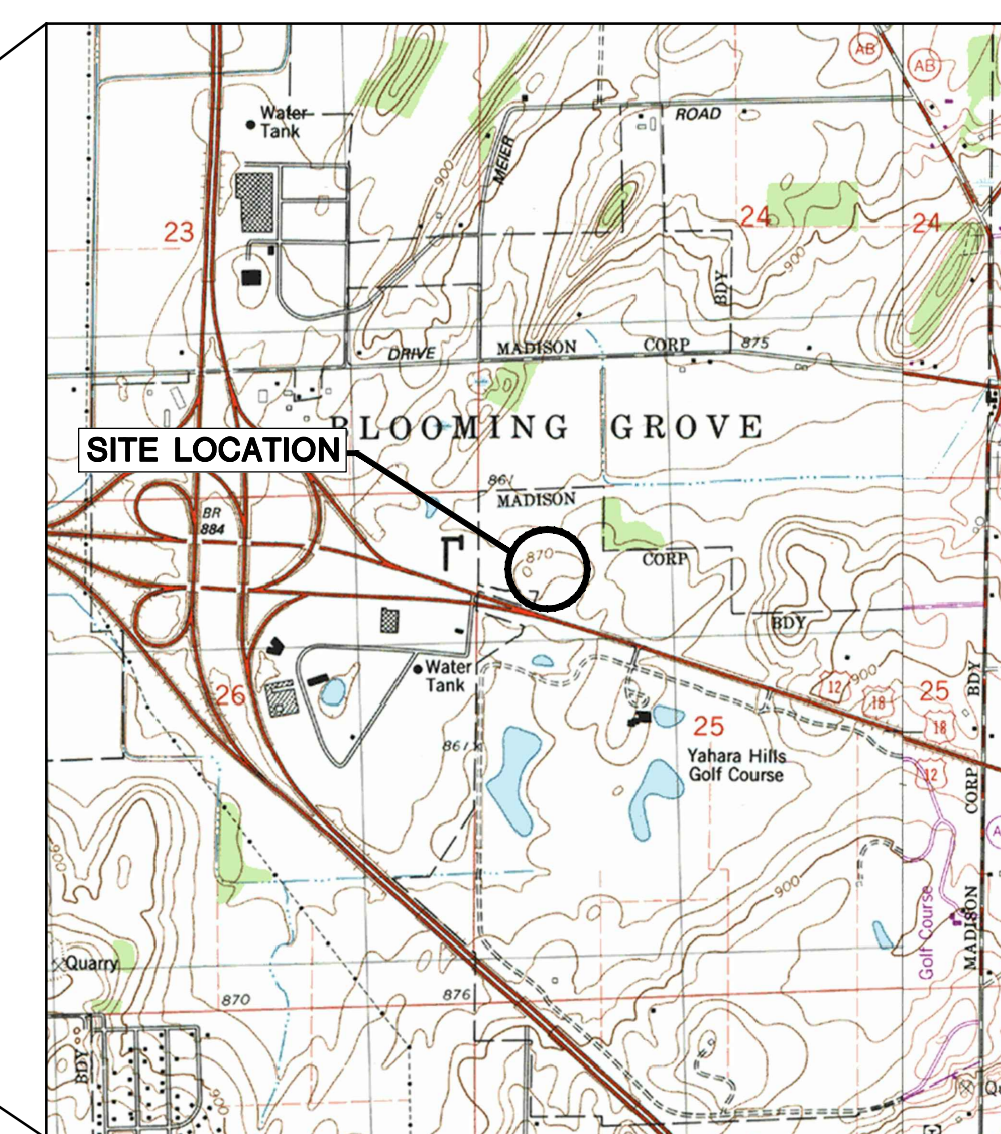

SITE
 LOCATOR MAP

APPROXIMATE SCALE: 1"=2,000'

INDEX

| | |
|---|---|
| <p>GENERAL G100 CIVIL C100 PROCESS Q100 Q200 Q201</p> | <p>TITLE SHEET EXISTING CONDITIONS GENERAL ARRANGEMENT EQUIPMENT ELEVATIONS - A-C EQUIPMENT ELEVATIONS - D-H</p> |
|---|---|



| REVISION | DATE | BY | TITLE |
|----------|------|----|-------|
| | | | |
| | | | |
| | | | |
| | | | |
| | | | |
| | | | |
| | | | |
| | | | |
| | | | |
| | | | |

PROJECT NO: 25214236.00
 DRAWN: 02/13/15
 REVISED: 06/02/15
 DRAWN BY: AHB
 CHECKED BY: MH
 APPROVED BY:

**BID DOCUMENTS
 BID NO. 315033
 ISSUED 06/03/15**

TITLE SHEET

SHEET NUMBER
G100

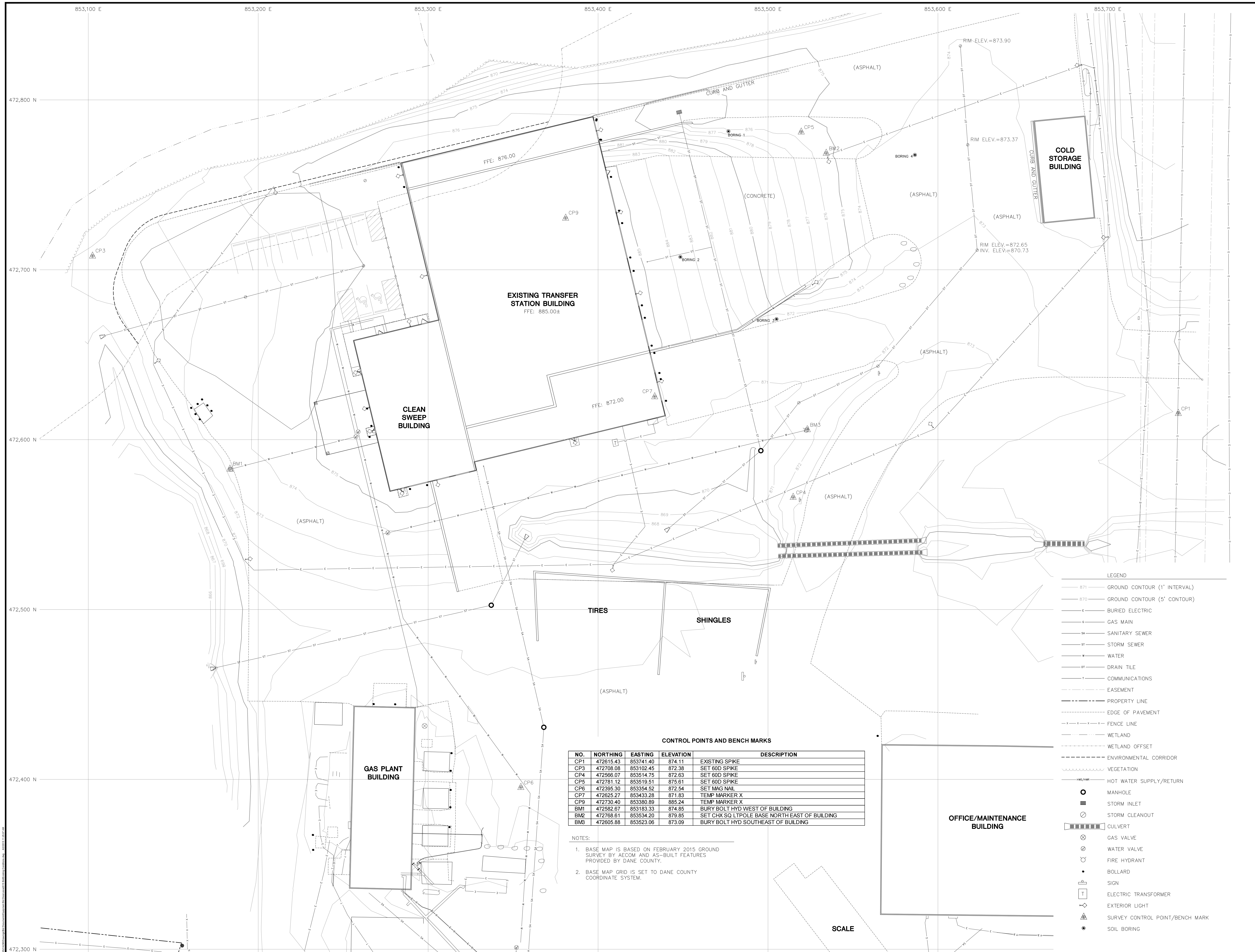

- LEGEND**
- 871 GROUND CONTOUR (1' INTERVAL)
 - 870 GROUND CONTOUR (5' CONTOUR)
 - BURIED ELECTRIC
 - GAS MAIN
 - SA SANITARY SEWER
 - SS STORM SEWER
 - WATER
 - DT DRAIN TILE
 - C COMMUNICATIONS
 - E EASEMENT
 - P PROPERTY LINE
 - EP EDGE OF PAVEMENT
 - FL FENCE LINE
 - W WETLAND
 - WO WETLAND OFFSET
 - EC ENVIRONMENTAL CORRIDOR
 - V VEGETATION
 - HW HOT WATER SUPPLY/RETURN
 - MH MANHOLE
 - SI STORM INLET
 - SC STORM CLEANOUT
 - CULVULT CULVERT
 - GV GAS VALVE
 - WV WATER VALVE
 - FH FIRE HYDRANT
 - B BOLLARD
 - S SIGN
 - ET ELECTRIC TRANSFORMER
 - EL EXTERIOR LIGHT
 - SCP SURVEY CONTROL POINT/BENCH MARK
 - SB SOIL BORING

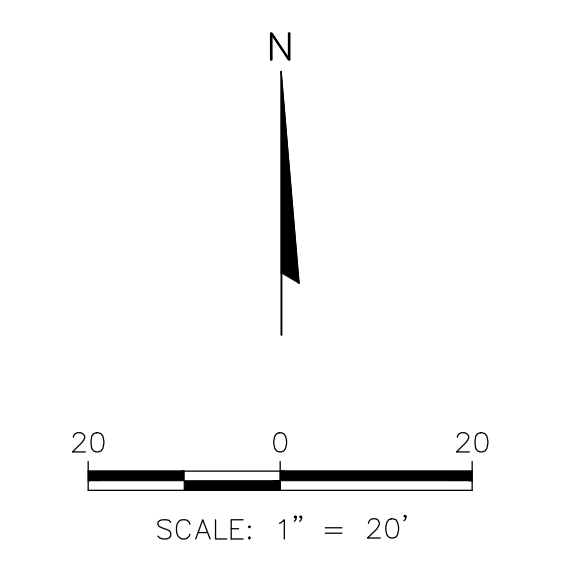

CONTROL POINTS AND BENCH MARKS

| NO. | NORTHING | EASTING | ELEVATION | DESCRIPTION |
|-----|-----------|-----------|-----------|---|
| CP1 | 472615.43 | 853741.40 | 874.11 | EXISTING SPIKE |
| CP3 | 472708.08 | 853102.45 | 872.38 | SET 60D SPIKE |
| CP4 | 472566.07 | 853514.75 | 872.63 | SET 60D SPIKE |
| CP5 | 472781.12 | 853519.51 | 875.61 | SET 60D SPIKE |
| CP6 | 472395.30 | 853354.52 | 872.54 | SET MAG NAIL |
| CP7 | 472625.27 | 853433.28 | 874.83 | TEMP MARKER X |
| CP9 | 472730.40 | 853380.89 | 865.24 | TEMP MARKER X |
| BM1 | 472582.67 | 853183.33 | 874.85 | BURY BOLT HYD WEST OF BUILDING |
| BM2 | 472768.61 | 853534.20 | 879.85 | SET CHX SQ LTPOLE BASE NORTH EAST OF BUILDING |
| BM3 | 472605.88 | 853523.06 | 873.09 | BURY BOLT HYD SOUTHEAST OF BUILDING |

- NOTES:**
- BASE MAP IS BASED ON FEBRUARY 2015 GROUND SURVEY BY AECOM AND AS-BUILT FEATURES PROVIDED BY DANE COUNTY.
 - BASE MAP GRID IS SET TO DANE COUNTY COORDINATE SYSTEM.

| REVISION | DATE | BY | TITLE |
|----------|------|----|-------|
| | | | |
| | | | |
| | | | |
| | | | |
| | | | |
| | | | |
| | | | |
| | | | |
| | | | |
| | | | |

PROJECT NO: 25214236.00
 DRAWN: 02/16/15
 REVISED: 06/02/15
 DRAWN BY: AHB
 CHECKED BY: MH
 APPROVED BY:

BID DOCUMENTS
BID NO. 315033
ISSUED 06/03/15

EXISTING CONDITIONS
 SHEET NUMBER
C100

| LEGEND | | |
|--------|-----|---|
| NO | QTY | DESCRIPTION |
| 1 | 1 | PRIMARY FINGER SCREEN |
| 2 | 1 | SLIDER BED CONVEYOR (PRIMARY FINGER SCREEN OVERS) |
| 3 | 1 | SLIDER BED CONVEYOR (PICKING A-LINE) |
| 4 | 1 | FERROUS MAGNET |
| 5 | 1 | SLIDER BED CONVEYOR (SECONDARY FINGER SCREEN INFEEED) |
| 6 | 1 | SECONDARY FINGER SCREEN |
| 7 | 1 | DE-STONER / AIR KNIFE |
| 8 | 1 | SLIDER BED CONVEYOR (DESTONER/AIR KNIFE OUTFEED) |
| 9 | 1 | SLIDER BED CONVEYOR (PICKING B-LINE) |
| 10 | 1 | TROUGHING IDLER CONVEYOR (SMALL RESIDUALS BUNKER) |
| 11 | 1 | TROUGHING IDLER CONVEYOR (PRIMARY FINGER SCREEN UNDERS) |
| 12 | 1 | SLIDER BED CONVEYOR (FINES BUNKER INFEEED) |
| 13 | 1 | DUST COLLECTOR / FILTER |
| 14 | 1 | AGGREGATE CONVEYOR |
| 15 | 1 | SLIDER BED CONVEYOR (AGGREGATE ON PLATFORM) |
| 16 | 1 | TILTING HOPPER |
| 17 | 1 | WOOD GRINDER (BY OTHERS SEE BID NO. 315029) |
| 18 | 1 | WOOD CONVEYOR (BY OTHERS SEE BID NO. 315029) |
| 19 | 1 | CARDBOARD BALER (PROVIDED AND INSTALLED BY OWNER) |

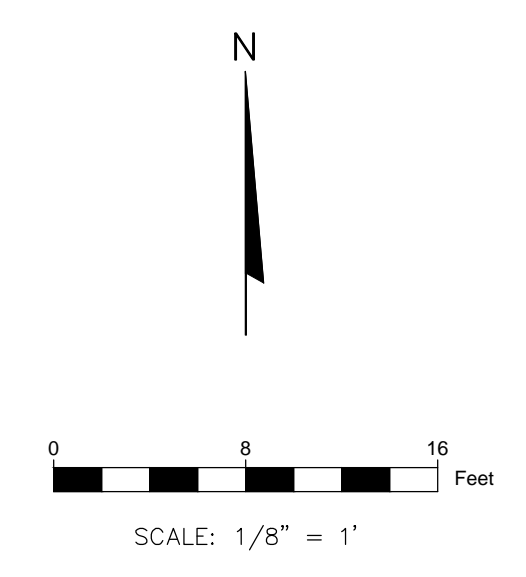
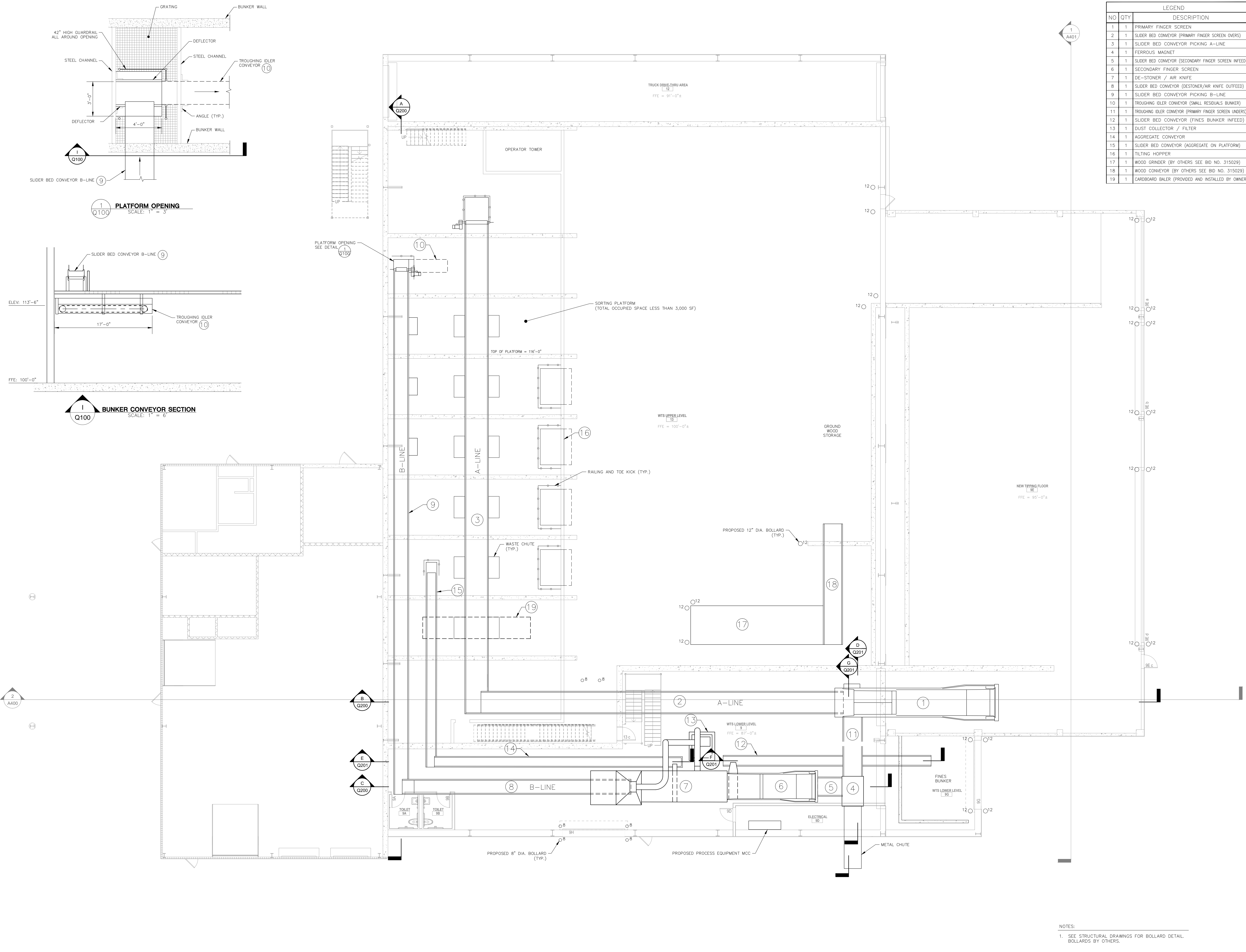
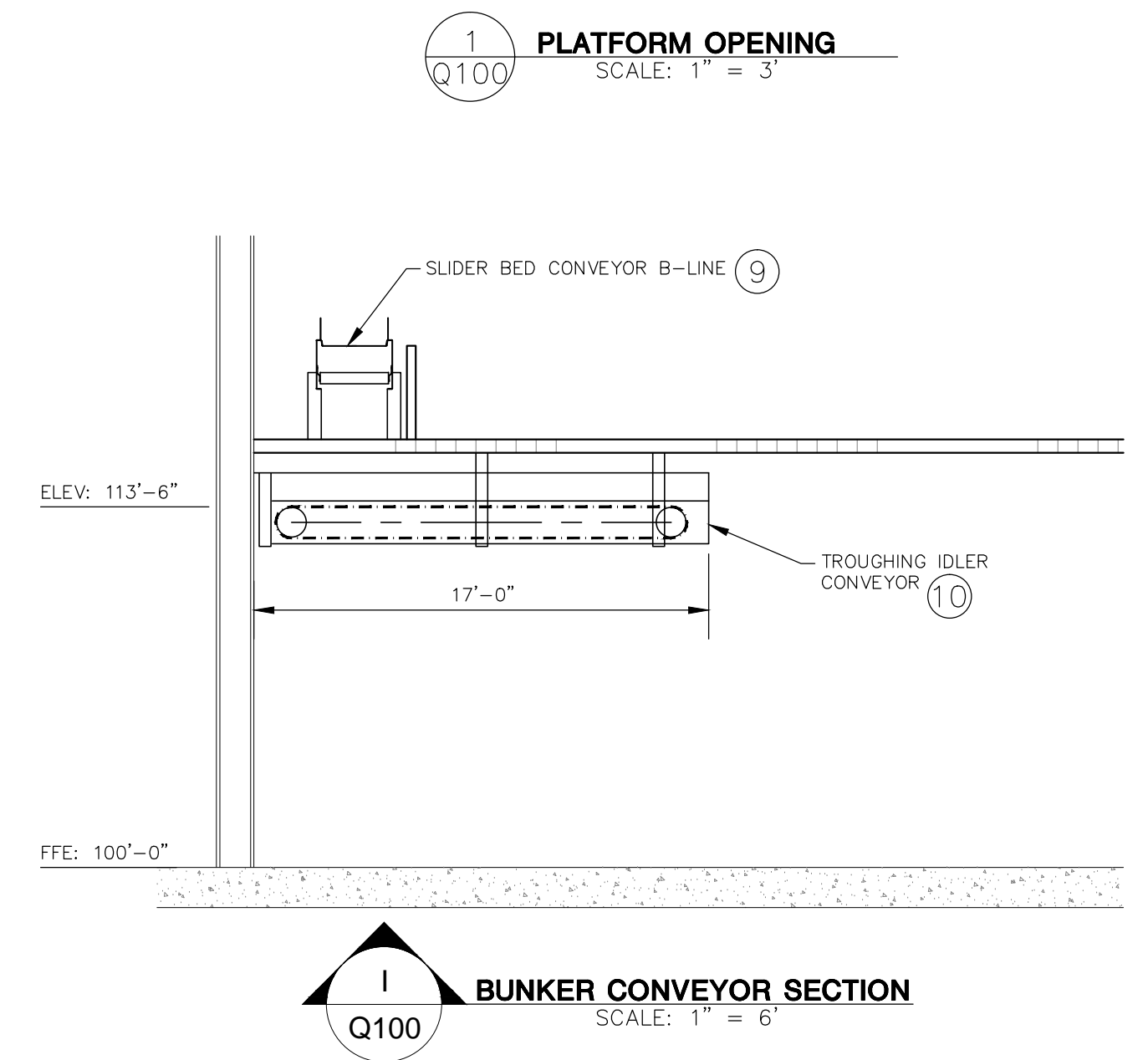
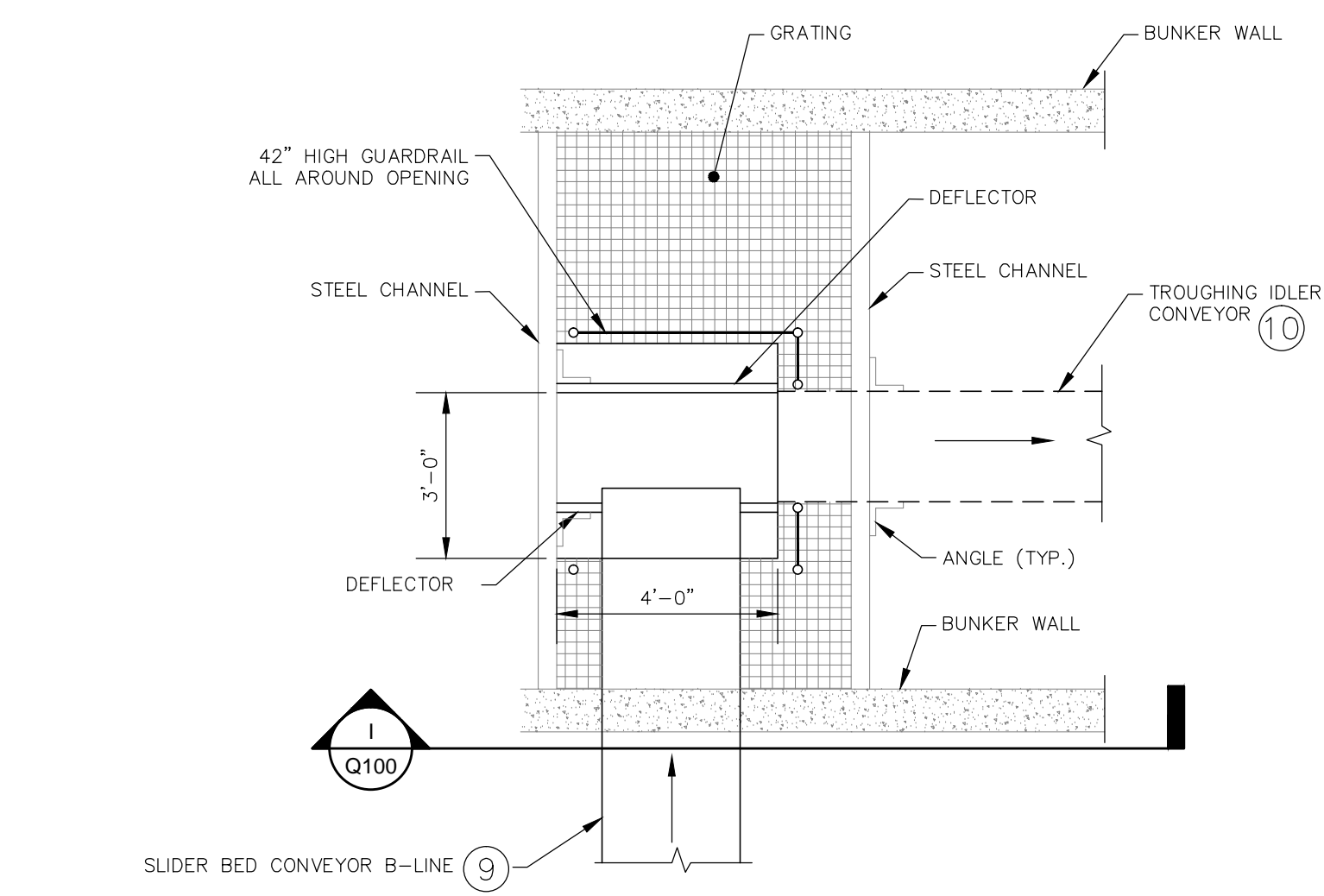

| REVISION | DATE | BY | TITLE |
|----------|------|----|-------|
| | | | |
| | | | |
| | | | |
| | | | |

| | |
|--------------|-------------|
| PROJECT NO. | 25214236.00 |
| DRAWN: | 01/22/15 |
| REVISED: | 05/28/15 |
| DRAWN BY: | KP |
| CHECKED BY: | BC/MH |
| APPROVED BY: | |

BID DOCUMENTS
BID NO. 315033
ISSUED 06/03/15

GENERAL ARRANGEMENT

SHEET NUMBER
Q100

NOTES:
 1. SEE STRUCTURAL DRAWINGS FOR BOLLARD DETAIL. BOLLARDS BY OTHERS.

| LEGEND | | |
|--------|-----|---|
| NO | QTY | DESCRIPTION |
| 1 | 1 | PRIMARY FINGER SCREEN |
| 2 | 1 | SLIDER BED CONVEYOR (PRIMARY FINGER SCREEN OVERS) |
| 3 | 1 | SLIDER BED CONVEYOR PICKING A-LINE |
| 4 | 1 | FERROUS MAGNET |
| 5 | 1 | SLIDER BED CONVEYOR (SECONDARY FINGER SCREEN INFED) |
| 6 | 1 | SECONDARY FINGER SCREEN |
| 7 | 1 | DE-STONER / AIR KNIFE |
| 8 | 1 | SLIDER BED CONVEYOR (DESTONER/AIR KNIFE OUTFEED) |
| 9 | 1 | SLIDER BED CONVEYOR PICKING B-LINE |
| 10 | 1 | TROUGHING IDLER CONVEYOR (SMALL RESIDUALS BUNKER) |
| 11 | 1 | TROUGHING IDLER CONVEYOR (PRIMARY FINGER SCREEN UNDERS) |
| 12 | 1 | SLIDER BED CONVEYOR (FINES BUNKER INFED) |
| 13 | 1 | DUST COLLECTOR / FILTER |
| 14 | 1 | AGGREGATE CONVEYOR |
| 15 | 1 | SLIDER BED CONVEYOR (AGGREGATE ON PLATFORM) |
| 16 | 1 | TILTING HOPPER |
| 17 | 1 | WOOD GRINDER (BY OTHERS SEE BID NO. 315029) |
| 18 | 1 | WOOD CONVEYOR (BY OTHERS SEE BID NO. 315029) |
| 19 | 1 | CARDBOARD BALER (PROVIDED AND INSTALLED BY OWNER) |

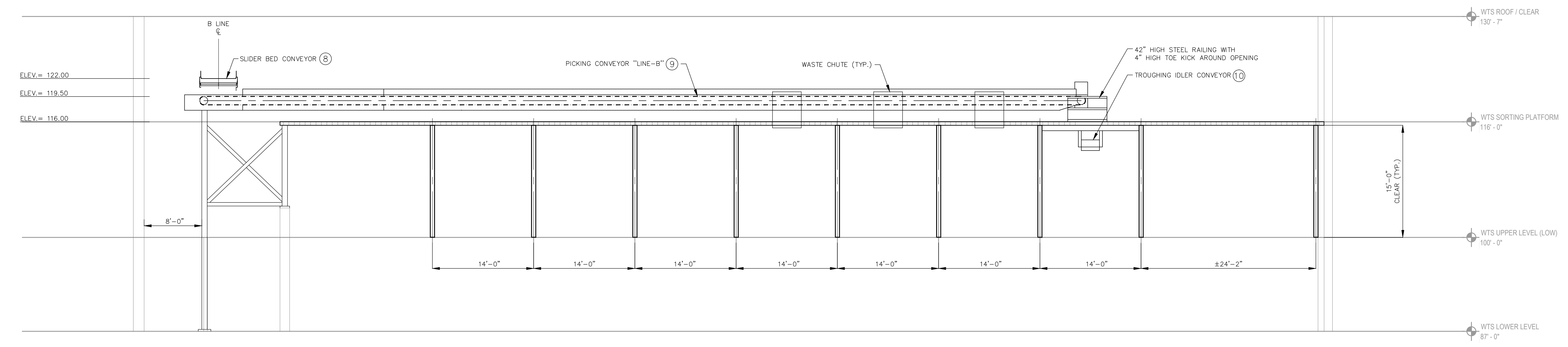

A
 B-LINE PICKING CONVEYOR ELEVATION
 Q200
 1/8" = 1'-0"

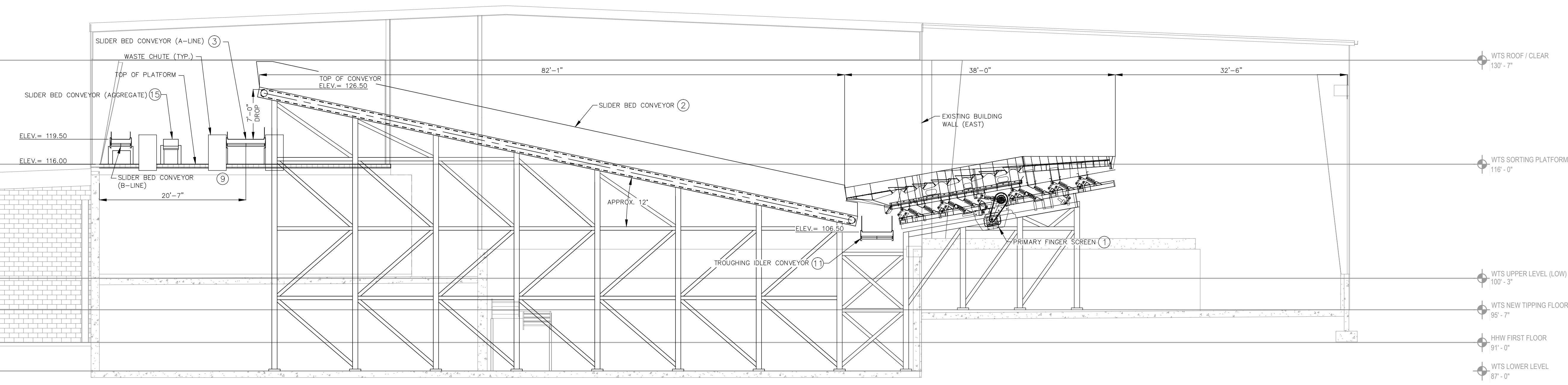

B
 A-LINE ELEVATION
 (BUILDING SECTION 2/A400 PROJECTED AS BACKGROUND)
 Q200
 1/8" = 1'-0"

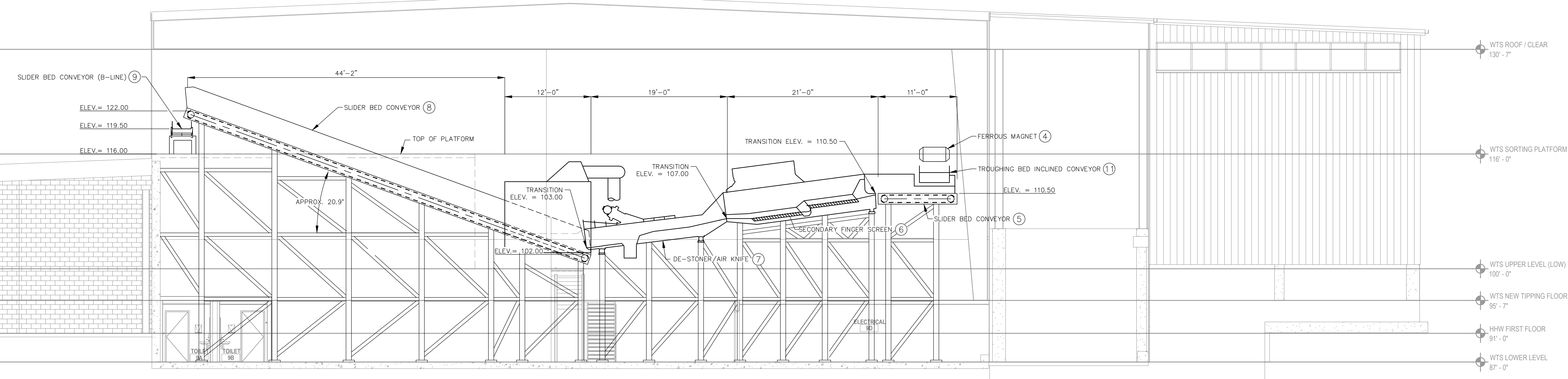

C
 B-LINE ELEVATION
 (BUILDING SECTION 1/A400 PROJECTED AS BACKGROUND)
 Q200
 1/8" = 1'-0"

| REVISION | DATE | BY | TITLE |
|----------|------|----|-------|
| | | | |
| | | | |
| | | | |
| | | | |

| | |
|--------------|-------------|
| PROJECT NO. | 25214236.00 |
| DRAWN: | 01/22/15 |
| REVISED: | 05/28/15 |
| DRAWN BY: | KP |
| CHECKED BY: | BC/MH |
| APPROVED BY: | |

BID DOCUMENTS
BID NO. 315033
ISSUED 06/03/15

EQUIPMENT ELEVATIONS
A-C

SHEET NUMBER
Q200

CONSTRUCTION AND DEMOLITION WASTE RECYCLING FACILITY
 7102 US HWY 12/18
 MADISON, WISCONSIN

DANE COUNTY DEPARTMENT OF PUBLIC WORKS
 SOLID WASTE DIVISION
 1919 ALLIANT ENERGY CENTER WAY
 MADISON, WI 53713

PROCESS AND CIVIL ENGINEER:
 SCS ENGINEERS
 2830 DAIRY DRIVE
 MADISON, WI 53718-6751
 (608) 224-2830

ARCHITECT:
 DORSCHNER ASSOCIATES, INC.
 849 E. WASHINGTON AVE., SUITE 112
 MADISON, WI 53703

STRUCTURAL ENGINEER:
 PIERCE ENGINEERS, INC.
 10 WEST MIFFLIN ST., SUITE 205
 MADISON, WI 53703

MECHANICAL, ELECTRIC, PLUMBING DESIGN:
 JDR ENGINEERING, INC.
 5525 NOBEL DRIVE, SUITE 110
 MADISON, WI 53711

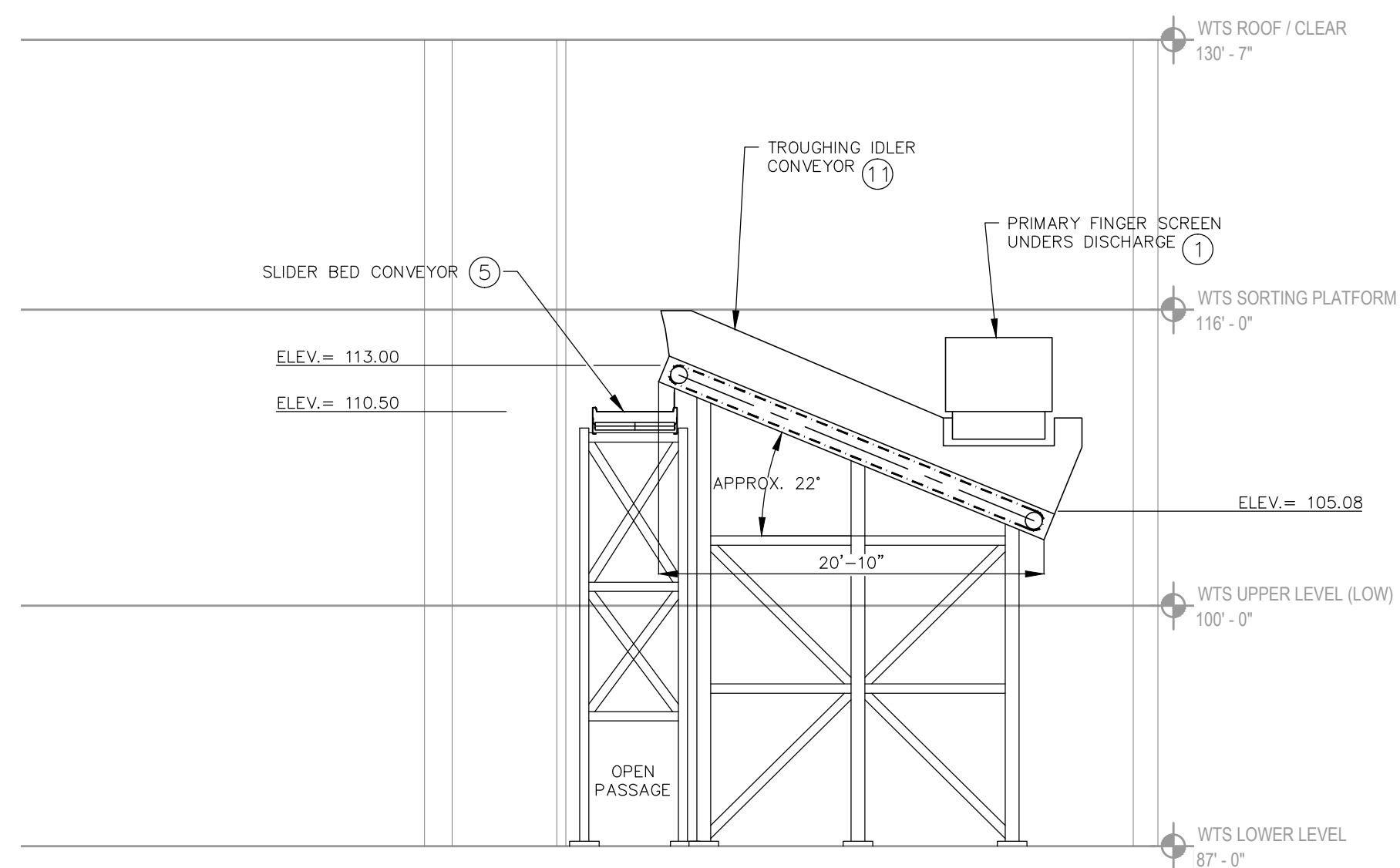

D
 Q201
 PRIMARY FINGER SCREEN UNDERS ELEVATION
 1/8" = 1'-0"

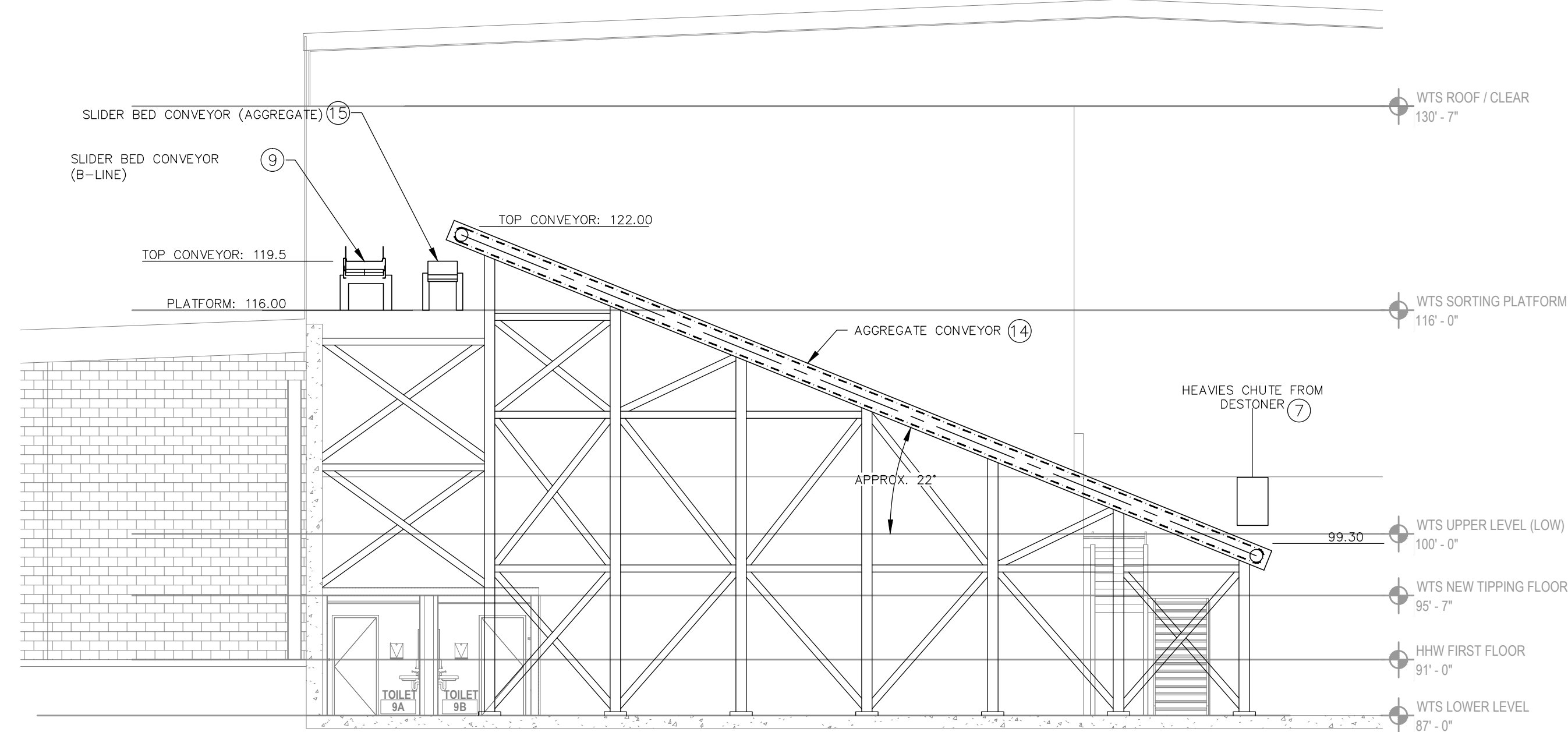

E
 Q201
 DESTONER HEAVIES CONVEYOR ELEVATION
 (BUILDING SECTION 1/A400 PROJECTED AS BACKGROUND)
 1/8" = 1'-0"

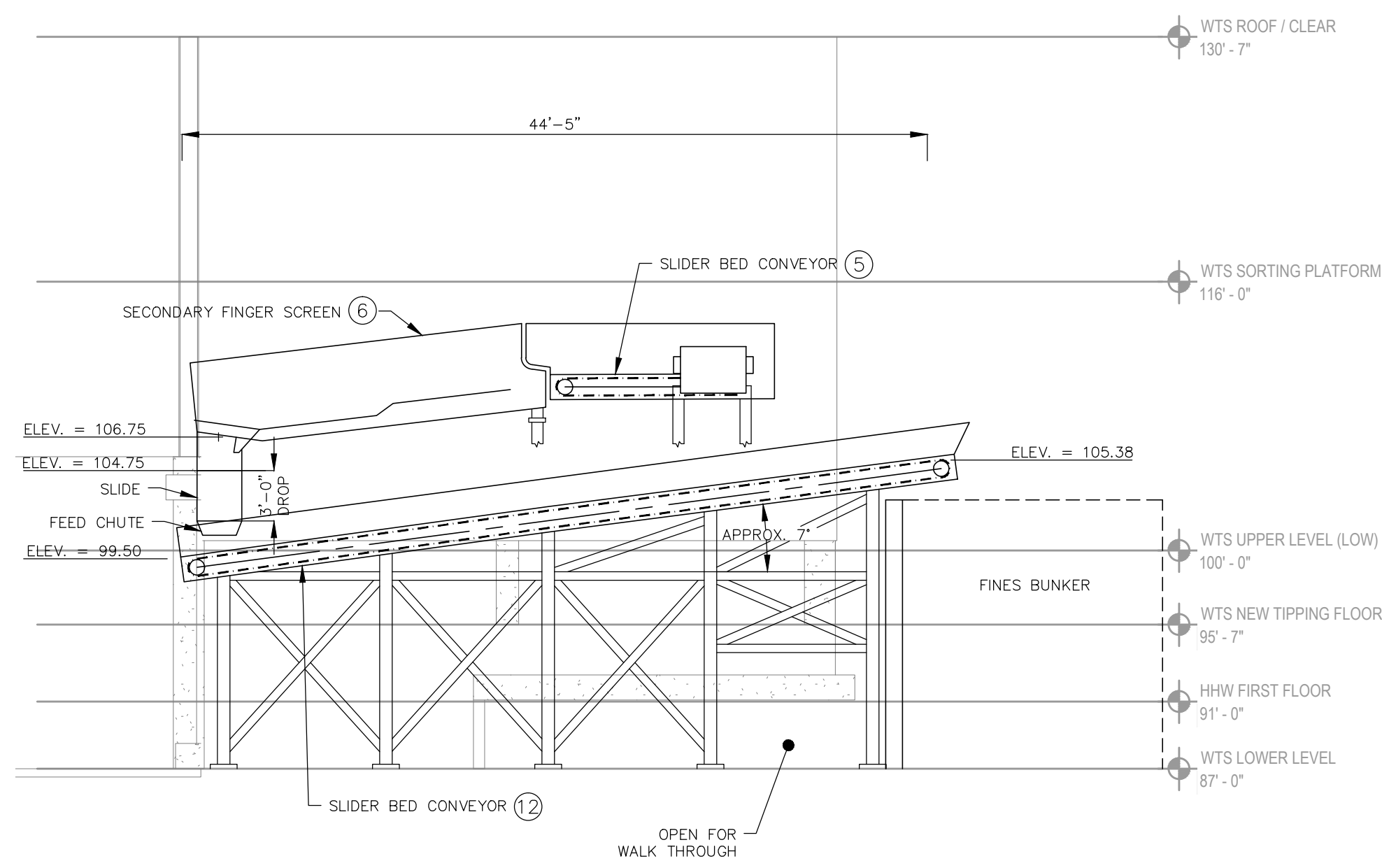

F
 Q201
 UNDERS CONVEYOR FROM B-LINE ELEVATION
 (BUILDING SECTION 1/A400 PROJECTED AS BACKGROUND)
 1/8" = 1'-0"

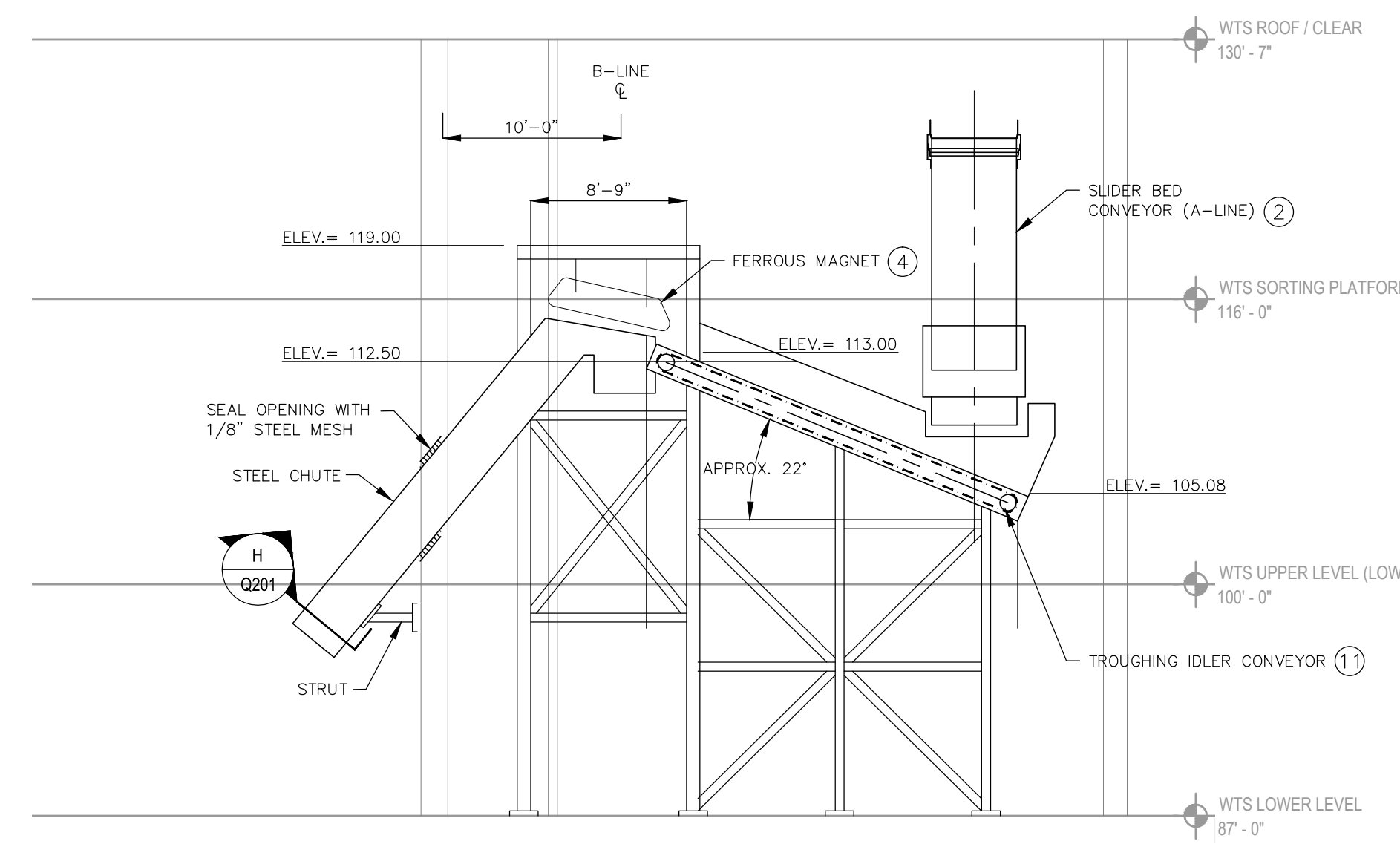

G
 Q201
 FERROUS MAGNET ELEVATION
 1/8" = 1'-0"

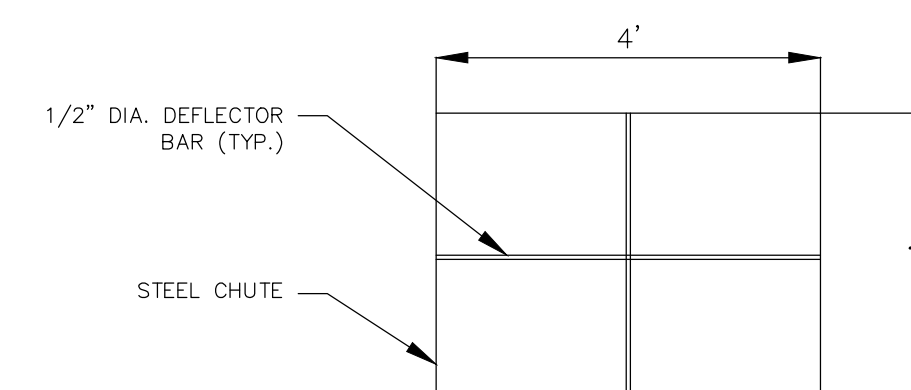

H
 Q201
 STEEL CHUTE SECTION
 1/2" = 1'-0"

| NO | | QTY | DESCRIPTION |
|----|---|-----|---|
| 1 | 1 | | PRIMARY FINGER SCREEN |
| 2 | 1 | | SLIDER BED CONVEYOR (PRIMARY FINGER SCREEN OVERS) |
| 3 | 1 | | SLIDER BED CONVEYOR (PICKING A-LINE) |
| 4 | 1 | | FERRROUS MAGNET |
| 5 | 1 | | SLIDER BED CONVEYOR (SECONDARY FINGER SCREEN INFEEED) |
| 6 | 1 | | SECONDARY FINGER SCREEN |
| 7 | 1 | | DE-STONER / AIR KNIFE |
| 8 | 1 | | SLIDER BED CONVEYOR (DESTONER/AIR KNIFE OUTFEED) |
| 9 | 1 | | SLIDER BED CONVEYOR (PICKING B-LINE) |
| 10 | 1 | | TROUGHING IDLER CONVEYOR (SMALL RESIDUALS BUNKER) |
| 11 | 1 | | TROUGHING IDLER CONVEYOR (PRIMARY FINGER SCREEN UNDERS) |
| 12 | 1 | | SLIDER BED CONVEYOR (FINES BUNKER INFEEED) |
| 13 | 1 | | DUST COLLECTOR / FILTER |
| 14 | 1 | | AGGREGATE CONVEYOR |
| 15 | 1 | | SLIDER BED CONVEYOR (AGGREGATE ON PLATFORM) |
| 16 | 1 | | TILTING HOPPER |
| 17 | 1 | | WOOD GRINDER (BY OTHERS SEE BID NO. 315029) |
| 18 | 1 | | WOOD CONVEYOR (BY OTHERS SEE BID NO. 315029) |
| 19 | 1 | | CARDBOARD BALER (PROVIDED AND INSTALLED BY OWNER) |

| REVISION | DATE | BY | TITLE |
|----------|------|----|-------|
| | | | |
| | | | |
| | | | |
| | | | |
| | | | |
| | | | |
| | | | |
| | | | |
| | | | |
| | | | |

| | |
|--------------|-------------|
| PROJECT NO. | 25214236.00 |
| DRAWN: | 01/22/15 |
| REVISED: | 05/28/15 |
| DRAWN BY: | KP |
| CHECKED BY: | BC/MH |
| APPROVED BY: | |

BID DOCUMENTS
BID NO. 315033
ISSUED 06/03/15

EQUIPMENT ELEVATIONS
D-H
 SHEET NUMBER
Q201

Appendix C

Standard Terms and Conditions

STANDARD TERMS AND CONDITIONS
(Request For Bids/Proposals/Contracts)
Dane County Solid Waste Division
Rev. 11/13

1.0 **APPLICABILITY:** The terms and conditions set forth in this document apply to Requests for Proposals (RFP), Bids and all other transactions whereby the County of Dane acquires goods or services, or both.

1.1 **ENTIRE AGREEMENT:** These Standard Terms and Conditions shall apply to any contract, including any purchase order, awarded as a result of this request. Special requirements of a resulting contract may also apply. Said written contract with referenced parts and attachments shall constitute the entire agreement, and no other terms and conditions in any document, acceptance, or acknowledgment shall be effective or binding unless expressly agreed to in writing by the County. Unless otherwise stated in the agreement, these standard terms conditions supersede any other terms and/or conditions applicable to this agreement.

1.2 **DEFINITIONS:** As used herein, "vendor" includes a provider of goods or services, or both, who is responding to an RFP or a bid, and "bid" includes a response to either an RFP or a bid.

2.0 **SPECIFICATIONS:** The specifications herein are the minimum acceptable. When specific manufacturer and model numbers are used, they are to establish a design, type of construction, quality, functional capability or performance level, or any combination thereof, desired. When alternates are proposed, they must be identified by manufacturer, stock number, and such other information necessary to establish equivalency. Dane County shall be the sole judge of equivalency. Vendors are cautioned to avoid proposing alternates to the specifications that may result in rejection of their bid.

3.0 **DEVIATIONS AND EXCEPTIONS:** Deviations and exceptions from terms, conditions, or specifications shall be described fully on the vendor's letterhead, signed, and attached to the bid. In the absence of such statement, the bid shall be accepted as in strict compliance with all terms, conditions, and specifications and vendor shall be held liable for injury resulting from any deviation.

4.0 **QUALITY:** Unless otherwise indicated in the request, all material shall be first quality. No pre-owned, obsolete, discontinued or defective materials may be used.

5.0 **QUANTITIES:** The quantities shown herein are based on estimated needs. The County reserves the right to increase or decrease quantities to meet actual needs.

6.0 **DELIVERY:** Deliveries shall be FOB destination freight prepaid and included unless otherwise specified. County will reject shipments sent C.O.D. or freight collect.

7.0 **PRICING:** Unit prices shown on the bid shall be the price per unit of sale as stated on the request or contract. For any given item, the quantity multiplied by the unit price shall establish the extended price, the unit price shall govern in the bid evaluation and contract administration.

7.1 Prices established in continuing agreements and term contracts may be lowered due to market conditions, but prices shall not be subject to increase for the term specified in the award. Vendor shall submit proposed increases to the contracting department thirty (30) calendar days before the proposed effective date of the price increase. Proposed increases shall be limited to fully documented cost increases to the vendor that are demonstrated to be industry wide. Price increases may not be granted unless they are expressed in bid documents and contracts or agreements.

7.2 Submission of a bid constitutes bidder's certification that no financial or personal relationship exists between the bidder and any county official or employee except as specially set forth in writing attached to and made a part of the bid. The successful bidder shall disclose any such relationship which develops during the term of the contract.

8.0 **ACCEPTANCE-REJECTION:** Dane County reserves the right to accept or reject any or all bids, to waive any technicality in any bid submitted and to accept any part of a bid as deemed to be in the best interests of the County. Submission of a proposal or a bid constitutes the making of an offer to contract and gives the County an option valid for 60 days after the date of submission to the County.

8.1 Bids **MUST** be dated and time stamped by the Dane County Solid Waste Division Office on or before the date and time that the bid is due. Bids deposited or time stamped in another office will be rejected. Actual receipt in the office of the Solid Waste Division is necessary; timely deposit in the mail system is not sufficient. **THERE WILL BE NO EXCEPTIONS TO THIS POLICY.**

9.0 **METHOD OF AWARD:** Award shall be made to the lowest responsible responsive vendor conforming to specifications, terms, and conditions, or to the most advantageous bid submitted to the County on a quality versus price basis.

10.0 **ORDERING/ACCEPTANCE:** Written notice of award to a vendor in the form of a purchase order or other document, mailed or delivered to the address shown on the bid will be considered sufficient notice of acceptance of bid. A formal contract containing all provisions of the contract signed by both parties shall be used when required by the Dane County Purchasing Division.

11.0 **PAYMENT TERMS AND INVOICING:** Unless otherwise agreed, Dane County will pay properly submitted vendor invoices within thirty (30) days of receipt of goods and services. Payment will not be made until goods or services are delivered, installed (if required), and accepted as specified. Invoices presented for payment must be submitted in accordance with instructions contained on the purchase order.

11.1 **NO WAIVER OF DEFAULT:** In no event shall the making of any payment or acceptance of any service or product required by this Agreement constitute or be construed

as a waiver by County of any breach of the covenants of the Agreement or a waiver of any default of the successful vendor, and the making of any such payment or acceptance of any such service or product by County while any such default or breach shall exist shall in no way impair or prejudice the right of County with respect to recovery of damages or other remedy as a result of such breach or default.

12.0 TAXES: The County and its departments are exempt from payment of all federal tax and Wisconsin state and local taxes on its purchases except Wisconsin excise taxes as described below. The State of Wisconsin Department of Revenue has issued tax exempt number ES41279 to Dane County.

12.1 The County is required to pay the Wisconsin excise or occupation tax on its purchase of beer, liquor, wine, cigarettes, tobacco products, motor vehicle fuel and general aviation fuel. The County is exempt from Wisconsin sales or use tax on these purchases. The County may be subject to other states' taxes on its purchases in that state depending on the laws of that state. Vendors performing construction activities are required to pay state use tax on the cost of materials.

13.0 GUARANTEED DELIVERY: Failure of the vendor to adhere to delivery schedules as specified or to promptly replace rejected materials shall render the vendor liable for all costs in excess of the contract price when alternate procurement is necessary. Excess costs shall include administrative costs.

14.0 APPLICABLE LAW AND VENUE: This contract shall be governed under the laws of the State of Wisconsin, and venue for any legal action between the parties shall be in Dane County Circuit Court. The vendor shall at all times comply with and observe all federal and state laws, local laws, ordinances, and regulations which are in effect during the period of this contract and which in any manner affect the work or its conduct.

15.0 ASSIGNMENT: No right or duty in whole or in part of the vendor under this contract may be assigned or delegated without the prior written consent of Dane County.

16.0 NONDISCRIMINATION/AFFIRMATIVE ACTION: During the term of this Agreement the vendor agrees, in accordance with sec. 111.321, Wis. Stats., and Chapter 19 of the Dane County Code of Ordinances, not to discriminate against any person, whether an applicant or recipient of services, an employee or applicant for employment, on the basis of age, race, ethnicity, religion, color, gender, disability, marital status, sexual orientation, national origin, cultural differences, ancestry, physical appearance, arrest record or conviction record, military participation or membership in the national guard, state defense force or any other reserve component of the military forces of the United States, or political beliefs. The vendor shall provide a harassment-free work environment. These provisions shall include, but not be limited to, the following: employment, upgrading, demotion, transfer, recruitment, advertising, layoff, termination, training, including apprenticeships, rates of pay or other forms of compensation.

16.1 Vendors who have twenty (20) or more employees and a contract of twenty thousand dollars (\$20,000) or more must submit a written affirmative action plan to the County's Contract Compliance Officer within fifteen (15) working days of the effective date of the contract. The County may elect to

accept a copy of the current affirmative action plan filed with and approved by a federal, state or local government unit.

16.2 The vendor agrees to post in conspicuous places, available for employees and applicants for employment, notices setting forth the provisions of this Agreement as they relate to affirmative action and nondiscrimination.

16.3 Failure to comply with these Terms and Conditions may result in the vendor being debarred, termination of the contract and/or withholding of payment.

16.4 The vendor agrees to furnish all information and reports required by Dane County's Contract Compliance Officer as the same relate to affirmative action and nondiscrimination, which may include any books, records, or accounts deemed appropriate to determine compliance with Chapter 19, D.C. Ords. and the provisions of this Agreement.

16.5 *Americans with Disabilities Act*: The vendor agrees to the requirements of the ADA, providing for physical and programmatic access to service delivery and treatment in all programs and activities.

17.0 PATENT, COPYRIGHT AND TRADEMARK INFRINGEMENT: The vendor guarantees goods sold to the County were manufactured or produced in accordance with applicable federal labor laws, and that the sale or use of the articles described herein do not infringe any patent, copyright or trademark. The vendor covenants that it will, at its own expense, defend every suit which shall be brought against the County (provided that such vendor is promptly notified of such suit, and all papers therein are delivered to it) for any alleged infringement of any patent, copyright or trademark by reason of the sale or use of such articles, and agrees that it will pay all costs, damages, and profits recoverable in any such suit.

18.0 SAFETY REQUIREMENTS: All materials, equipment, and supplies provided to the County must fully comply with all safety requirements as set forth by the Wisconsin Department of Commerce and all applicable OSHA Standards.

18.1 MATERIAL SAFETY DATA SHEET: If any item(s) on an order(s) resulting from this award(s) is a hazardous chemical, as defined under 29 CFR 1910.1200, provide one (1) copy of the Material Safety Data Sheet for each item with the shipped container(s) and one (1) copy with the invoice(s).

19.0 WARRANTY: Unless specifically expressed otherwise in writing, goods and equipment purchased as a result of this request shall be warranted against defects by the vendor for one (1) year from date of receipt. An equipment manufacturer's standard warranty shall apply as a minimum and must be honored by the vendor. The time limitation in this paragraph does not apply to the warranty provided in paragraph 27.0.

20.0 INDEMNIFICATION & INSURANCE.

20.1 PROVIDER shall indemnify, hold harmless and defend COUNTY, its boards, commissions, agencies, officers, employees and representatives against any and all liability, loss (including, but not limited to, property damage, bodily injury and loss of life), damages, costs or expenses which COUNTY, its officers, employees, agencies, boards, commissions and representatives may sustain, incur or be required to pay by reason of PROVIDER furnishing the services or goods required to be provided under this

Agreement, provided, however, that the provisions of this paragraph shall not apply to liabilities, losses, charges, costs, or expenses caused by or resulting from the acts or omissions of COUNTY, its agencies, boards, commissions, officers, employees or representatives. The obligations of PROVIDER under this paragraph shall survive the expiration or termination of this Agreement.

20.2. In order to protect itself and COUNTY, its officers, boards, commissions, agencies, agents, volunteers, employees and representatives under the indemnity provisions of the subparagraph above, PROVIDER shall, at PROVIDER's own expense, obtain and at all times during the term of this Agreement keep in full force and effect the insurance coverages, limits, and endorsements listed below. When obtaining required insurance under this Agreement and otherwise, PROVIDER agrees to preserve COUNTY's subrogation rights in all such matters that may arise that are covered by PROVIDER's insurance. Neither these requirements nor the COUNTY's review or acceptance of PROVIDER's certificates of insurance is intended to limit or qualify the liabilities or obligations assumed by the PROVIDER under this Agreement. The County expressly reserves the right to require higher or lower insurance limits where County deems necessary.

20.2.1. Commercial General Liability. PROVIDER agrees to maintain Commercial General Liability insurance at a limit of not less than \$1,000,000 per occurrence. Coverage shall include, but not be limited to, Bodily Injury and Property Damage to Third Parties, Contractual Liability, Personal Injury and Advertising Injury Liability, Premises-Operations, Independent PROVIDERs and Subcontractors, and Fire Legal Liability. The policy shall not exclude Explosion, Collapse, and Underground Property Damage Liability Coverage. The policy shall list DANE COUNTY as an Additional Insured.

20.2.2. Commercial/Business Automobile Liability. PROVIDER agrees to maintain Commercial/Business Automobile Liability insurance at a limit of not less than \$1,000,000 Each Occurrence. PROVIDER further agrees coverage shall include liability for Owned, Non-Owned & Hired automobiles. In the event PROVIDER does not own automobiles, PROVIDER agrees to maintain coverage for Hired & Non-Owned Auto Liability, which may be satisfied by way of endorsement to the Commercial General Liability policy or separate Business Auto Liability policy.

20.2.3. Environmental Impairment (Pollution) Liability. PROVIDER agrees to maintain Environmental Impairment (Pollution) Liability insurance at a limit of not less than \$1,000,000 per occurrence for bodily injury, property damage, and environmental cleanup costs caused by pollution conditions, both sudden and non-sudden. This requirement can be satisfied by either a separate environmental liability policy or through a modification to the Commercial General Liability policy. Evidence of either must be provided.

20.2.4. Workers' Compensation. PROVIDER agrees to maintain Workers Compensation insurance at Wisconsin statutory limits.

20.2.5. Umbrella or Excess Liability. PROVIDER may satisfy the minimum liability limits required above for Commercial General Liability and Business Auto Liability under an Umbrella or Excess Liability policy. There is no minimum Per Occurrence limit of liability under the Umbrella or Excess Liability; however, the Annual Aggregate limit shall

not be less than the highest "Each Occurrence" limit for the Commercial General Liability and Business Auto Liability. PROVIDER agrees to list DANE COUNTY as an "Additional Insured" on its Umbrella or Excess Liability policy.

20.3. Upon execution of this Agreement, PROVIDER shall furnish COUNTY with a Certificate of Insurance listing COUNTY as an additional insured and, upon request, certified copies of the required insurance policies. If PROVIDER's insurance is underwritten on a Claims-Made basis, the Retroactive Date shall be prior to or coincide with the date of this Agreement, the Certificate of Insurance shall state that professional malpractice or errors and omissions coverage, if the services being provided are professional services coverage is Claims-Made and indicate the Retroactive Date, PROVIDER shall maintain coverage for the duration of this Agreement and for six (6) years following the completion of this Agreement. PROVIDER shall furnish COUNTY, annually on the policy renewal date, a Certificate of Insurance as evidence of coverage. It is further agreed that PROVIDER shall furnish the COUNTY with a 30-day notice of aggregate erosion, in advance of the Retroactive Date, cancellation, or renewal. It is also agreed that on Claims-Made policies, either PROVIDER or COUNTY may invoke the tail option on behalf of the other party and that the Extended Reporting Period premium shall be paid by PROVIDER. In the event any action, suit or other proceeding is brought against COUNTY upon any matter herein indemnified against, COUNTY shall give reasonable notice thereof to PROVIDER and shall cooperate with PROVIDER's attorneys in the defense of the action, suit or other proceeding. PROVIDER shall furnish evidence of adequate Worker's Compensation Insurance. In case of any sublet of work under this Agreement, PROVIDER shall furnish evidence that each and every subcontractor has in force and effect insurance policies providing coverage identical to that required of PROVIDER. In case of any sublet of work under this Agreement, PROVIDER shall furnish evidence that each and every subcontractor has in force and effect insurance policies providing coverage identical to that required of PROVIDER.

20.4. The parties do hereby expressly agree that COUNTY, acting at its sole option and through its Risk Manager, may waive any and all requirements contained in this Agreement, such waiver to be in writing only. Such waiver may include or be limited to a reduction in the amount of coverage required above. The extent of waiver shall be determined solely by COUNTY's Risk Manager taking into account the nature of the work and other factors relevant to COUNTY's exposure, if any, under this Agreement.

21.0 CANCELLATION: County reserves the right to terminate any Agreement due to non-appropriation of funds or failure of performance by the vendor. This paragraph shall not relieve County of its responsibility to pay for services or goods provided or furnished to County prior to the effective date of termination.

22.0 PUBLIC RECORDS ACCESS: It is the intention of the County to maintain an open and public process in the solicitation, submission, review, and approval of procurement activities. Bid openings are public unless otherwise specified. Records are not available for public inspection prior to issuance of the notice of intent to award or the award of the contract. Bid results may be obtained by visiting the Dane County Purchasing Office Monday – Friday, between 8:00 a.m. and 4:00 p.m. Prior appointment is advisable.

22.1 PROPRIETARY INFORMATION: If the vendor asserts any of its books and records of its business practices and other matters collectively constitute a trade secret as that term is defined in s. 134.90(1)(c), Wis. Stats., County will not release such records to the public without first notifying the vendor of the request for the records and affording the vendor an opportunity to challenge in a court of competent jurisdiction the requester's right to access such records. The entire burden of maintaining and defending the trade secret designation shall be upon the vendor. The vendor acknowledges and agrees that if the vendor shall fail, in a timely manner, to initiate legal action to defend the trade secret designation or be unsuccessful in its defense of that designation, County shall be obligated to and will release the records.

22.2 Any material submitted by the vendor in response to this request that the vendor considers confidential and proprietary information and which vendor believes qualifies as a trade secret, as provided in section 19.36(5), Wis. Stats., must be identified on a designation of Confidential and Proprietary Information form. Pricing will not be held confidential after award of contract.

22.3 Data contained in a bid, all documentation provided therein, and innovations developed as a result of the contracted commodities or services cannot be copyrighted or patented. All data, documentation, and innovations shall be the property of the County.

23.0 RECYCLED MATERIALS: Dane County is required to purchase products incorporating recycled materials whenever technically and economically feasible. Vendors are encouraged to bid products with recycled content which meet specifications.

24.0 PROMOTIONAL ADVERTISING: Reference to or use of Dane County, any of its departments or sub-units, or any county official or employee for commercial promotion is prohibited.

25.0 ANTITRUST ASSIGNMENT: The vendor and the County of Dane recognize that in actual economic practice, overcharges resulting from antitrust violation are in fact usually borne by the Purchaser. Therefore, the successful vendor hereby assigns to the County of Dane any and all claims for such overcharges as to goods, materials or services purchased in connection with this contract.

26.0 RECORDKEEPING AND RECORD RETENTION-PUBLIC WORKS CONTRACTS: The successful bidder on a public works contract shall comply with the State of Wisconsin prevailing wage scale and shall establish and maintain adequate payroll records for all labor utilized as well as records for expenditures relating to all subcontracts, materialmen and suppliers. All records must be kept in accordance with generally accepted accounting procedures. The County shall have the right to audit, review, examine, copy, and transcribe any such records or documents. The vendor will retain all documents applicable to the contract for a period of not less than three (3) years after final payment is made.

26.1 RECORDKEEPING AND RECORD RETENTION-COST REIMBURSEMENT CONTRACTS: Where payment to the vendor is based on the vendor's costs, vendor shall establish and maintain adequate records of all expenditures incurred under the contract. All records must be kept in accordance with generally accepted accounting procedures. The County contracting agency shall have the right to audit,

review, examine, copy, and transcribe any pertinent records or documents relating to any contract resulting from this bid/proposal held by the vendor. The vendor will retain all documents applicable to the contract for a period of not less than three (3) years after final payment is made.

27.0 LIVING WAGE REQUIREMENT: The vendor shall, where appropriate, comply with the County's Living Wage requirements as set forth in section 25.015, Dane County Ordinances.

27.01 In the event its payroll records contain any false, misleading or fraudulent information, or if the vendor fails to comply with the provisions of s. 25.015, D.C. Ords., the County may withhold payments on the contract, terminate, cancel or suspend the contract in whole or in part, or, after a due process hearing, deny the vendor the right to participate in bidding on future County contracts for a period of one (1) year after the first violation is found and for a period of three (3) years after a second violation is found.

27.02 Bidders are exempt from the requirement of this section if:

- The maximum value of services to be provided is less than \$5,000;
- The bid involves only the sale of goods to the County;
- The bid is for professional services;
- The bid is for a public works contract where wages are regulated under s. 62.293, Wis. Stats.;
- The bidder is a school district, a municipality, or other unit of government;
- The service to be provided is residential services at an established per bed rate;
- The bidder's employees are persons with disabilities working in employment programs and the successful bidder holds a current sub-minimum wage certificate issued by the U.S. Department of Labor or where such a certificate could be issued but for the fact that the employer is paying a wage higher than the minimum wage;
- The bidder is an individual providing services to a family member; or
- The bidder's employees are student interns.

27.03 COMPLIANCE WITH FAIR LABOR STANDARDS. During the term of this Agreement, PROVIDER shall report to the County Contract Compliance Officer, within ten (10) days, any allegations to, or findings by the National Labor Relations Board (NLRB) or Wisconsin Employment Relations Commission (WERC) that PROVIDER has violated a statute or regulation regarding labor standards or relations within the seven years prior to entering this Agreement. If an investigation by the Contract Compliance Officer results in a final determination that the matter adversely affects PROVIDER'S responsibilities under this Agreement, and which recommends termination, suspension or cancellation of this agreement, the County may take such action.

27.04 PROVIDER may appeal any adverse finding by the Contract Compliance Officer as set forth in sec. 25.015(11)(c) through (e).

27.05 PROVIDER shall post the following statement in a prominent place visible to employees: "As a condition of receiving and maintaining a contract with Dane County, this employer shall comply with federal, state and all other applicable laws prohibiting retaliation for union organizing."