

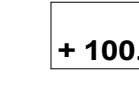







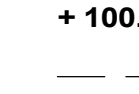

DRAWING LEGEND

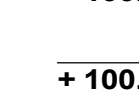
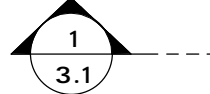
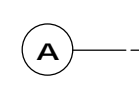
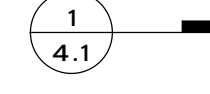
	+ 100.0 New or Required Point Elevation		Detail Number
	+ 100.0 Existing Point Elevation		Page Number
	+ 100.0 Existing Contours		Building Section
	+ 100.0 New or Required Contours		Wall Section
	Grid Lines		Detail Section
	Room 1 Room/Space Number		Interior Elevation
	Door Number		Exterior Elevation
	Wall Tag		

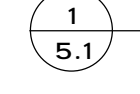
CONSULTANTS

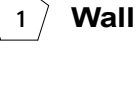
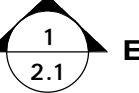
CIVIL	Snyder & Associates (608) 838-0444 Project Manager - Brett D. Biver	5010 Voges Road Madison, WI 53718
ARCHITECT	Kueny Architects, LLC (262) 857-8101 Architect of Record - Jon Wallenkamp	10505 Corporate Drive, Suite 100 Pleasant Prairie, Wisconsin 53158
PLUMBING	Southport Engineered Systems (262) 854-6630 Project Manager - Robert F. Novak	205 N. Dewey Street Eau Claire, Wisconsin 54703
H.V.A.C.	Southport Engineered Systems (262) 854-6630 Project Manager - Tim Pann	6919 51st Street Kenosha, Wisconsin 53144
ELECTRICAL	Hanson and Associates (262) 654-2012 Project Manager - David L. Hanson	6402 32nd Avenue Kenosha, Wisconsin 53142



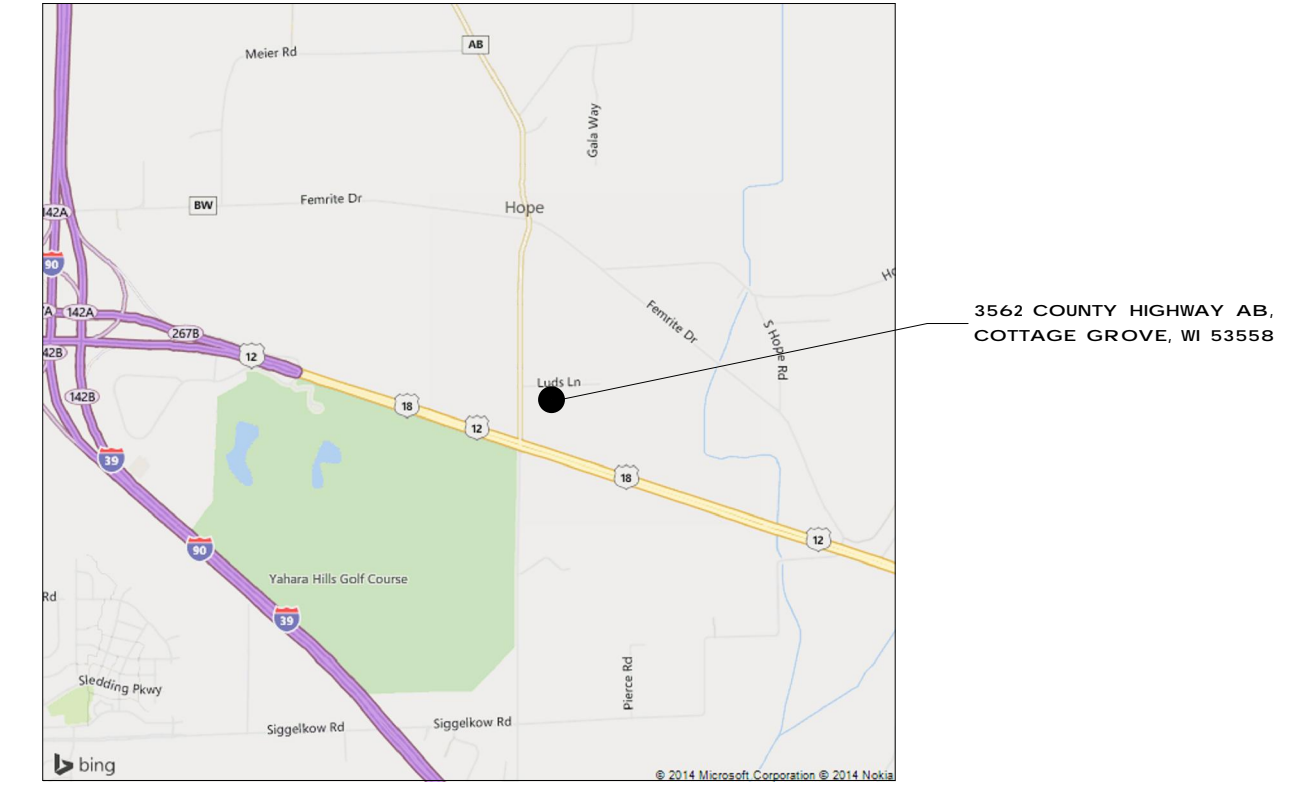







SITE MAP

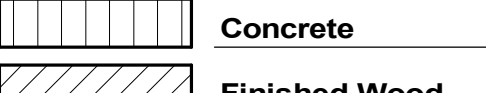
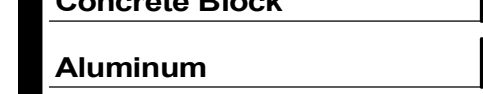

GENERAL NOTES

- All concrete to test 4000 psi in 28 days.
- Verify all dimensions, access, utilities and working conditions in the field.
- Conform to all applicable codes, ordinances and safety standards.
- Obtain and pay for all required permits and fees.
- Notify Architect immediately if work cannot proceed as shown on Drawings or as described in the Specifications.
- No concrete to be poured without Architect's prior review.
- All Contractor's to co-operate with all trades, Owner's and Architect's representatives.
- Leave site clean, neat and free of debris at all times.
- Each Prime and Sub-contractor is responsible for having read each page of the Specifications, Drawings, Addenda and Change Orders.
- Guard against interfering with Owner's operations.
- These Drawings contain no provisions or procedures for on-site safety. Each Contractor and their employees are responsible to follow all laws and ordinances and provide their own engineering to provide a safe work place.
- The locations of existing underground utilities, shown on these Drawings, are shown in an approximate way only and have not been independently verified by the Owner or its representatives. The Contractor shall determine the exact location of all existing utilities before commencing work, and agrees to be fully responsible for any and all damages which might be occasioned by the Contractor's failure to exactly locate and preserve any and all underground utilities.
- Services performed for this project have been conducted in a manner consistent with the level of care and skill ordinarily exercised by members of the profession currently practicing in this area under similar budget and time constraints. No warranty, expressed or implied, is made.

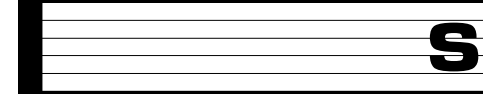
MATERIAL INDICATIONS

	Earth Backfill		Sand Fill
	Rigid Insulation		Concrete
	Concrete Block		Finished Wood
	Aluminum		Stone Fill
	Lumber (Rough)		Plywood
	Steel		Batt Insulation

SHEET INDEX

1.0 Title Sheet	FIRE PROTECTION
CIVIL	FP200 Fire Protection Overall Plan
C-101 Existing Site, Demo and Erosion Control	FP201 Fire Protection Office and Details
C-102 Phase 1 Site Plan	PLUMBING
C-103 Phase 1 Grading, Erosion Control/Drainage	P-001 Plumbing Site Plan
C-104 Phase 1 Utilities	P-200 Plumbing Overall Underground Plan
C-105 Phase 1 Paving Plan	P-201 Plumbing Overall Above Ground Plan
C-106 Phase 1 Grading (East)	P-202 Plumbing Mezzanine and Fire Pump Plan
C-107 Phase 1 Grading (West)	P-203 Plumbing Office Plan
C-108 Phase 1 & 2 Site Plan	P-204 Plumbing Plan and Schedules
ARCHITECTURAL	P-300 Plumbing Domestic Water Isometrics
A-101 Master Coordination Site Plan	P-301 Plumbing Domestic Water Isometrics, Schedules, and Details
A-102 Site Plan - Phase 1	P-302 Plumbing Waste and Vent Isometrics
A-103 Landscape Plan - Phase 1	P-303 Plumbing Locker Room Waste and Vent Isometrics
A-110 Satellite Building - Site Plan	P-304 Plumbing Compressed Air Isometrics and Details
A-200 Master Floor and Code Plan	P-305 Car Wash Supplemental Drawing
A-201 First Floor Plan	P-306 Storm Isometric
A-202 Mezzanine Floor Plan	MECHANICAL
A-203 Roof Plan	M-001 Mechanical Site Plan
A-204 Enlarged Plans	M-200 Mechanical Office Plan
A-205 Stair Plans	M-201 Mechanical First Floor Plan
A-206 Exterior Elevations	M-202 Mechanical Mezzanine Floor Plan
A-207 Exterior Elevations	M-203 Mechanical Roof Plan
A-208 Salt Building Plans	M-204 Alt Radiant Floor Plan - Storage
A-209 Salt Building Elevations & Sections	M-205 Alt Radiant Floor Plan - Office
A-210 Satellite Building - Floor Plan and Roof Plan	M-206 Mech Detail Plans and Sections
A-211 Satellite Building - Exterior Elevations	M-207 Salt Shed Mech Plan
A-212 Pump House - Floor Plans, Sections, & Details	M-208 Mechanical Plan and Schedules
A-213 Fuel Island Plans	M-300 Mechanical Schedules
A-223 Roof Plan Iso	M-301 Mechanical Details
A-301 Building Sections	M-302 Mechanical Details
A-302 Building Sections	ELECTRICAL
A-401 Wall Sections	E-101 Electrical Site Plan
A-402 Wall Sections	E-201 Office and Small Vehicle Storage Lighting Plan
A-403 Wall Sections	E-202 Large Vehicle Storage Lighting Plan
A-404 Wall Sections	E-203 Weld Shop, Large Vehicle Storage Lighting Plan
A-405 Wall Sections	E-204 Mezzanine Lighting Plan
A-406 Wall Sections	E-205 Office and Small Vehicle Storage Power and Systems Plan
A-407 Wall Sections	E-206 Large Vehicle Storage Power and Systems Plan
A-408 Wall Sections	E-207 Weld Bay, Large Vehicle Storage Power and Systems Plan
A-409 Entrance Details	E-208 Mezzanine Power and Systems Plan
A-410 Salt Building Sections and Details	E-209 Salt Building Electrical Plan
A-411 Salt Building Details	E-210 Fire Pump Building Plan, Emergency Generator
A-412 Satellite Building Wall Sections	E-211 Satellite Building Electrical Plans
A-413 Satellite Building Wall Sections	E-501 Schedules, Details
A-501 Building Details	E-502 Schedules, Details
A-502 Building Details	E-503 Schedules, Details
A-601 Door Schedule	E-504 Schedules, Details
A-602 Room Finish Schedule	E-505 Schedules, Details
A-701 Interior Elevations	E-506 Schedules, Details
A-702 Interior Elevations, Floor Finish & Details	E-507 Schedules, Details
STRUCTURAL	DATA & COMMUNICATION
S-901 Foundation Plan	IT-200 Data Plans
S-902 Mezzanine Framing Plan	
S-903 Roof Framing Plan	
S-904 Structural Details	
S-905 Special Joists and Girders	
S-906 Special Joists	
S-907 Special Joists	
S-908 Special Joists	
S-909 Special Joists	
S-910 Satellite Building - Foundation Plan	

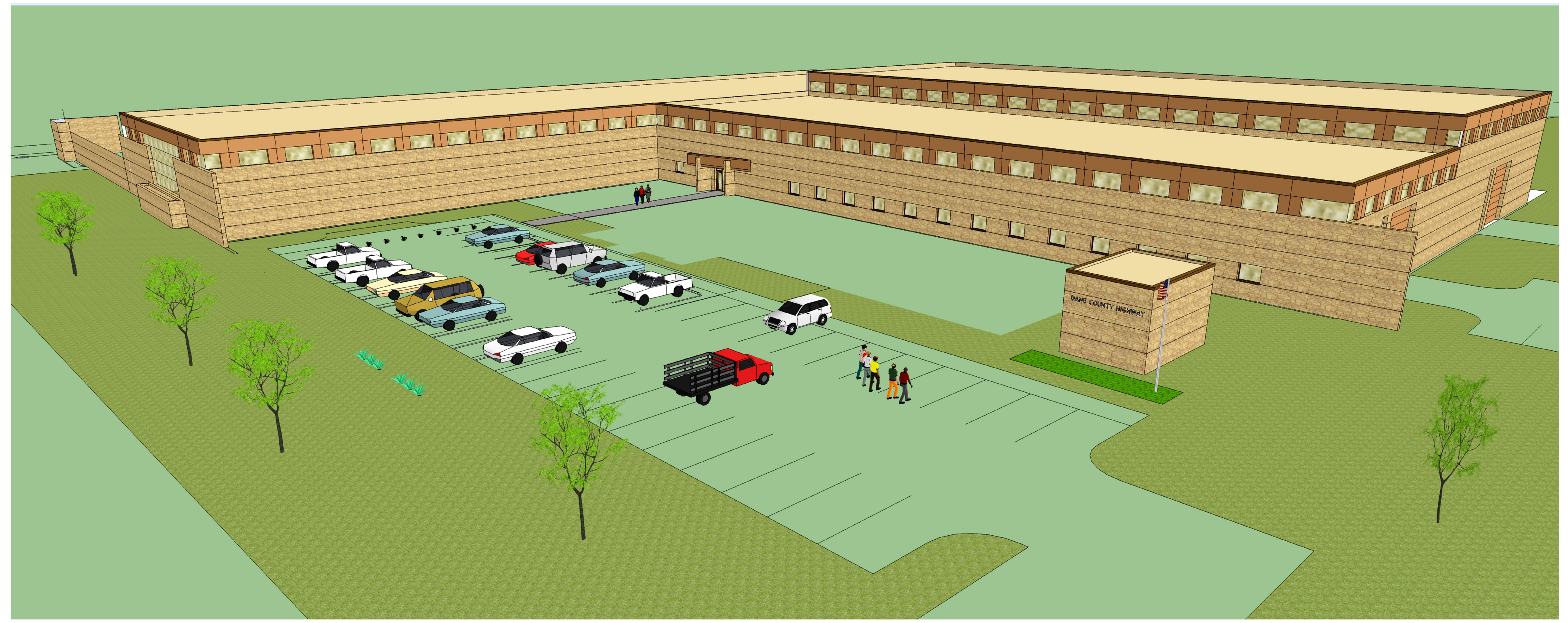

Dane County Highway Facility
Dane County

3562 County Highway AB,
Cottage Grove, WI 53558

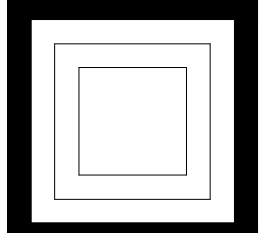

KUENY ARCHITECTS, LLC
10505 CORPORATE DRIVE - SUITE 100 PLEASANT PRAIRIE, WI 53158

PHONE (262) 857-8101 FAX (262) 857 8103

Dane County
Dane County Highway Facility
January 12, 2015

1.0

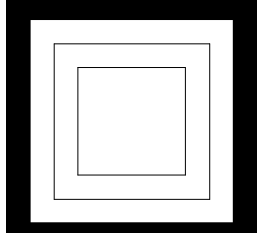

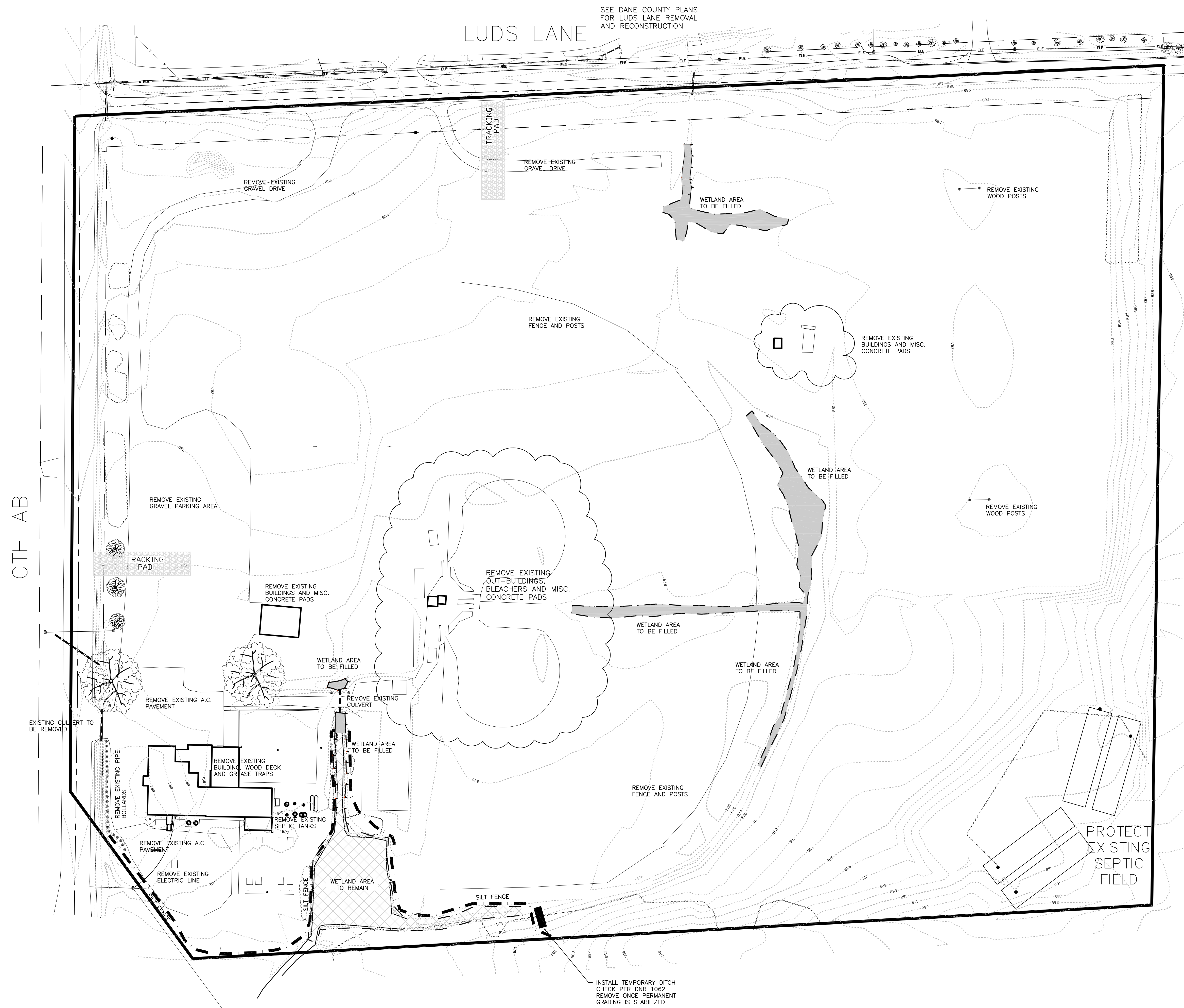

GENERAL NOTES:

STONE CONSTRUCTION ENTRANCE SHALL BE INSTALLED PRIOR TO ANY GRADING OPERATIONS AND MAINTAINED UNTIL GRAVEL BASE COURSE IS PLACED.

SILT FENCE SHALL BE INSTALLED PRIOR TO ANY GRADING OPERATIONS AND MAINTAINED THROUGHOUT THE CONSTRUCTION PHASE OF THIS PROJECT.

ALL DISTURBED AREAS, OTHER THAN PAVED OR BUILDING AREAS, SHALL RECEIVE SEED MIXTURE 40 IN ACCORDANCE WITH SECTION 630 OF D.O.T. SPECIFICATIONS AND SHALL BE APPLIED AT A RATE OF THREE POUNDS PER 1,000 SQUARE FEET. FERTILIZER SHALL MEET THE REQUIREMENTS THAT FOLLOW: NITROGEN, NOT LESS THAN 16%; PHOSPHORIC ACID, NOT LESS THAN 8%; POTASH, NOT LESS THAN 8%. FERTILIZER SHALL BE APPLIED AT THE RATE OF SEVEN POUNDS PER 1,000 SQUARE FEET. MULCHING APPLICATION SHALL CONSIST OF STRAW AT A RATE OF 1.5 TONS PER ACRE.

TRACKED MATERIAL TO ADJACENT STREETS SHALL BE COLLECTED AT THE END OF EACH WORK DAY OR AS REQUIRED BY THE TOWN.

EROSION AND SEDIMENT CONTROL MEASURES SHALL BE INSPECTED AND REPAIRED BY THE CONTRACTOR, IF NECESSARY, EVERY 7 DAYS AND WITHIN 24 HOURS AFTER A PRECIPITATION EVENT OF 0.5" OR GREATER. ALL NECESSARY MAINTENANCE SHOULD FOLLOW THE INSPECTIONS WITHIN 24 HOURS.

ALL EROSION CONTROL MEASURES ARE TO REMAIN IN PLACE UNTIL UPSTREAM AREAS HAVE BEEN STABILIZED. ONCE UPSTREAM AREAS ARE STABILIZED TEMPORARY EROSION CONTROL DEVICES ARE TO BE REMOVED.

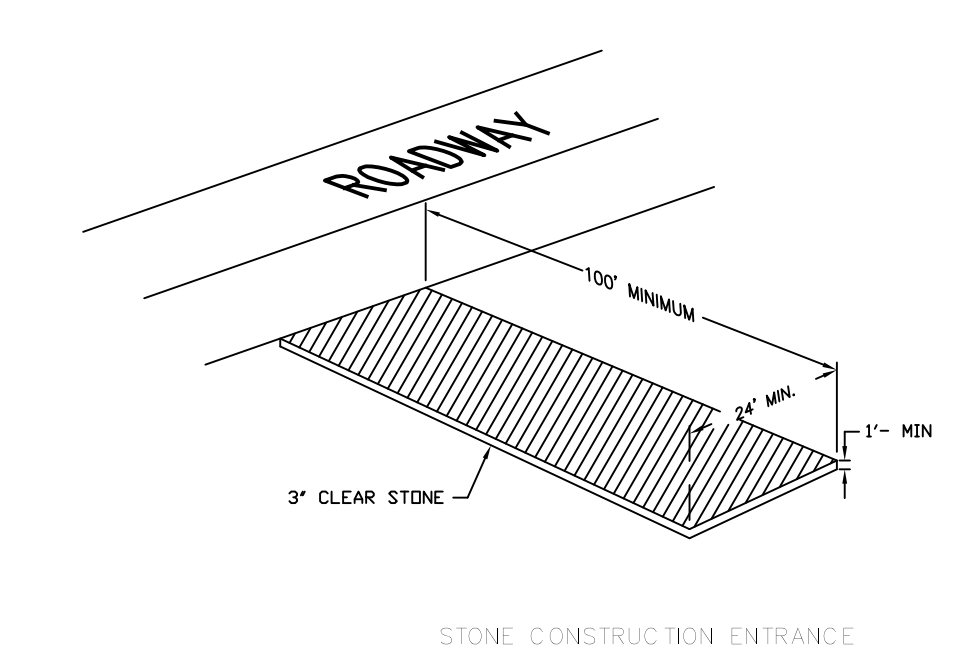
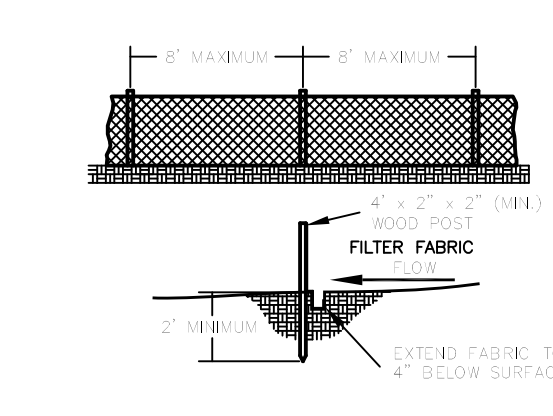

APPROXIMATE PROJECT SCHEDULE:

EROSION CONTROL MEASURES INSTALLED:	15 NOVEMBER 2014
BEGIN GRADING:	16 NOVEMBER 2014
INSTALL STORM SEWER PIPING AND UTILITIES:	7 JANUARY 2015
GRAVEL BASE COURSE INSTALLED:	1 FEBRUARY 2015
SITE PAVING:	1 MAY 2015
FERTILIZE, SEED, & MULCH SITE:	1 JUNE 2015
SITE ESTABLISHED:	1 AUGUST 2015



LUDS LANE (DESIGN BY DANE COUNTY)

CTH AB (DESIGN BY DANE COUNTY)

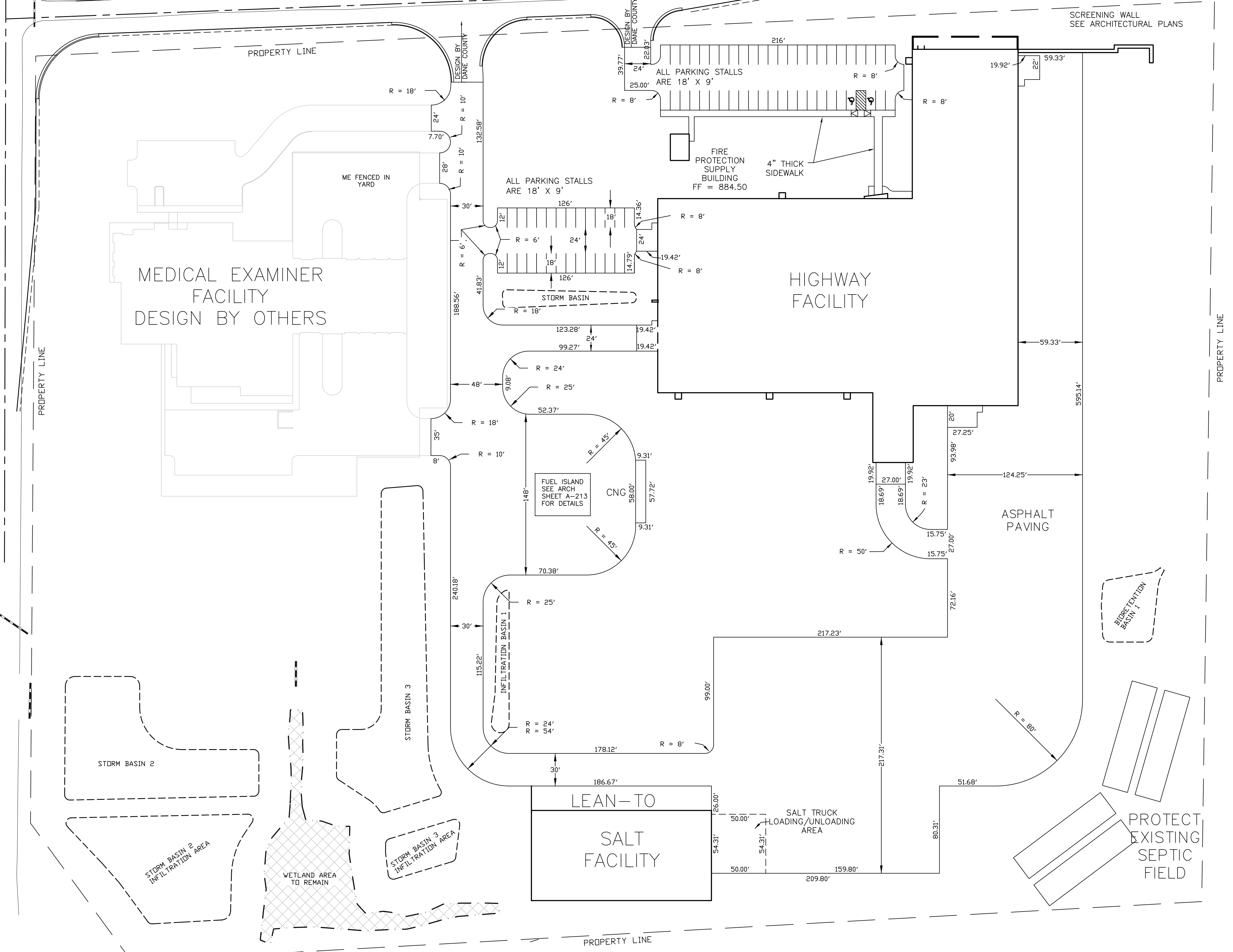

MEDICAL EXAMINER FACILITY
DESIGN BY OTHERS

HIGHWAY FACILITY

LEAN-TO
SALT FACILITY

ASPHALT PAVING

PROTECT
EXISTING
SEPTIC FIELD

SCREENING WALL
SEE ARCHITECTURAL PLANS

PROPERTY LINE

PROPERTY LINE

PROPERTY LINE

PROPERTY LINE

ME FENCED IN
YARD

ALL PARKING STALLS
ARE 18' X 9'

ALL PARKING STALLS
ARE 18' X 9'

FIRE PROTECTION
SUPPLY
BUILDING
FF = 884.50

ALL PARKING STALLS
ARE 18' X 9'

STORM BASIN

FUEL ISLAND
SEE ARCH SHEET A-213
FOR DETAILS

CNG

STORM BASIN 2

STORM BASIN 3

STORM BASIN 2
INFILTRATION AREA

STORM BASIN 3
INFILTRATION AREA

WETLAND AREA
TO REMAIN

BIURETIVITY
BASIN 1

SALT TRUCK
LOADING/UNLOADING
AREA

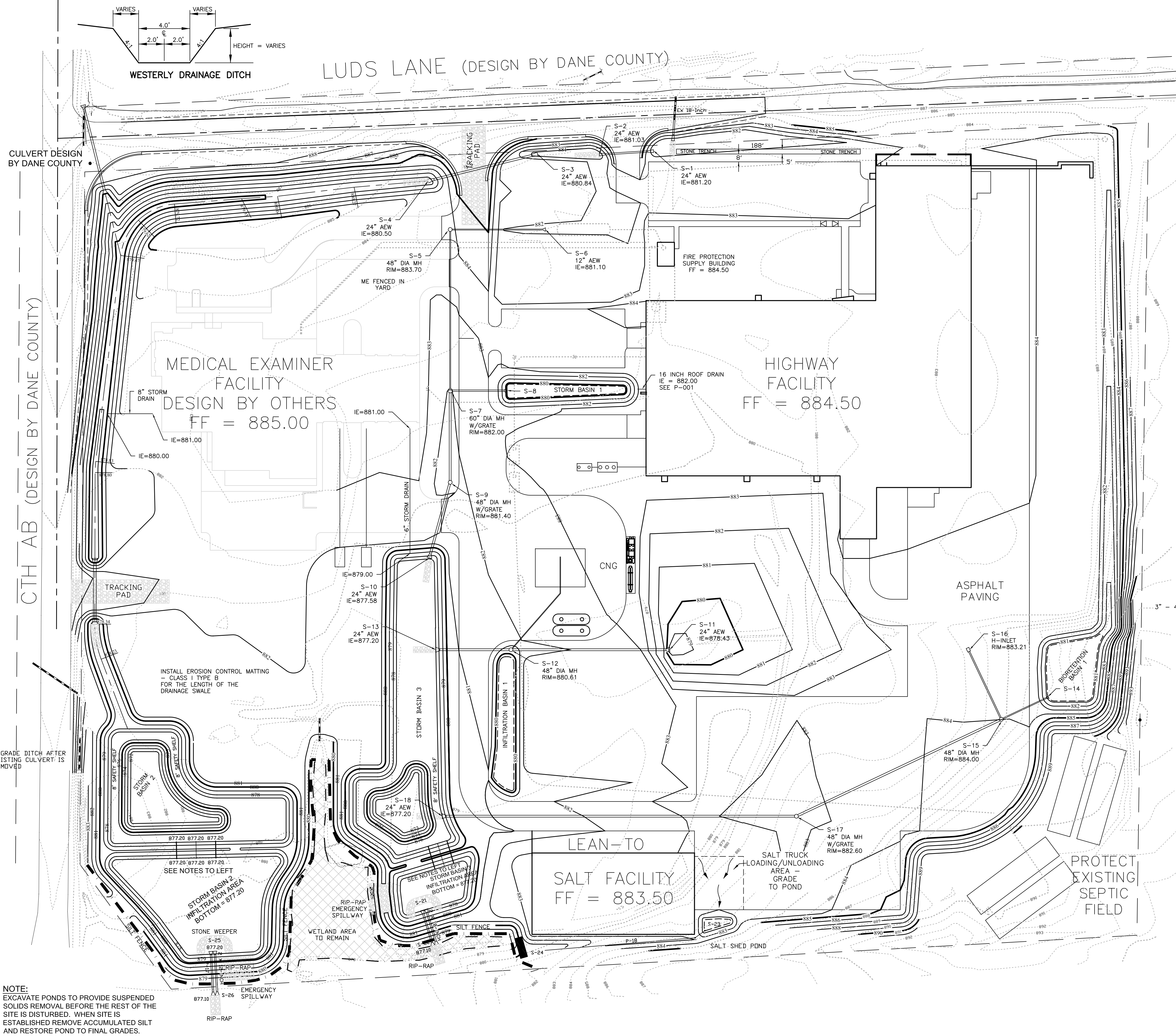

NOTE:
EXCAVATE PONDS TO PROVIDE SUSPENDED SOLIDS REMOVAL BEFORE THE REST OF THE SITE IS DISTURBED. WHEN SITE IS ESTABLISHED REMOVE ACCUMULATED SILT AND RESTORE POND TO FINAL GRADES.

NOTES:
INSTALL TWO (2) 12" x 20" HDPE PIPES. COVER NORTH END WITH 3" CLEAR STONE AND INSTALL A REMOVABLE CAP AT SOUTH END.
INSTALL A 6" x 20" HDPE PIPE COVER BOTH ENDS WITH 3" CLEAR STONE

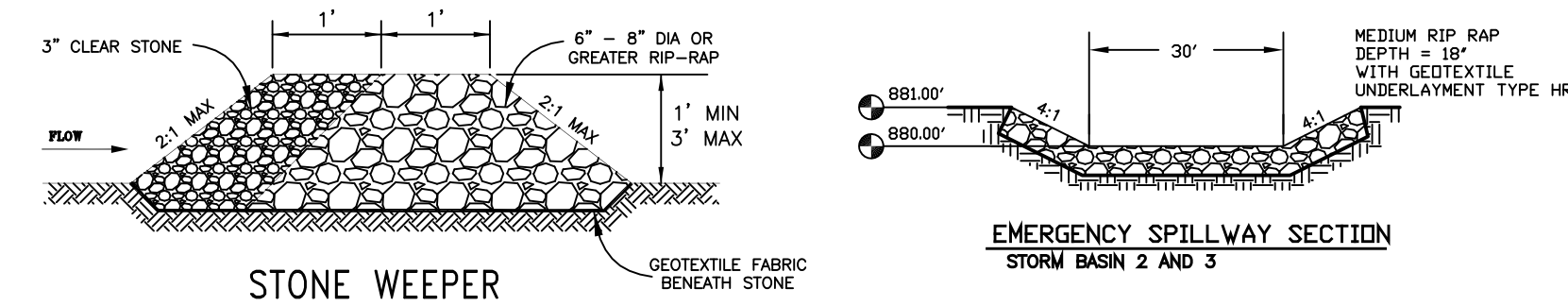

RIP-RAP OUTLET PROTECTION DIMENSIONS				
STRUCTURE NUMBER	PIPE DIAMETER INCHES	D ₅₀ CUBICAL INCHES	LENGTH (L) FEET	WIDTH (W) FEET
EXISTING 15"	18	6	21	5
S-2	24	6	21	5
S-4	24	6	21	5
S-10	24	6	25	6
S-13	24	6	23	6
S-18	24	6	21	6
S-20	36	6	21	6
S-22	2 x 18	6	28	12
S-26	2 x 12	6	20	10

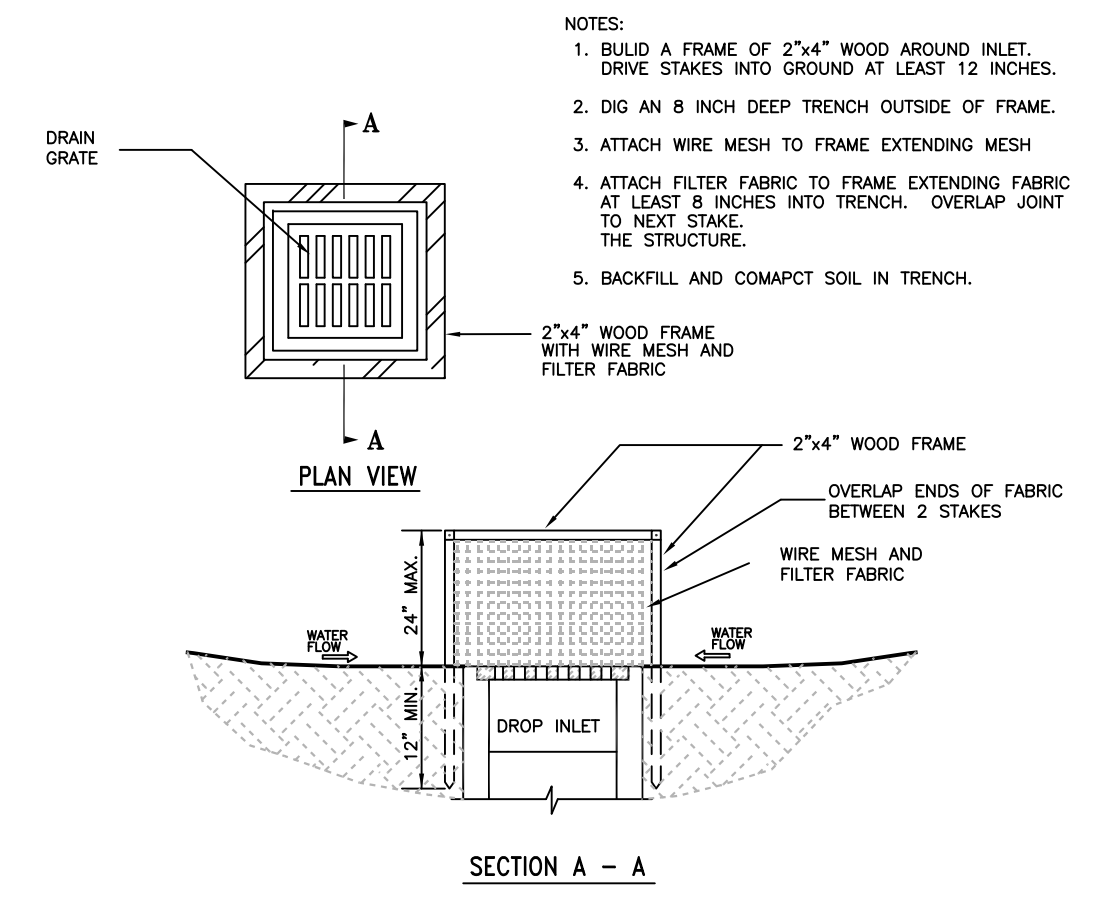
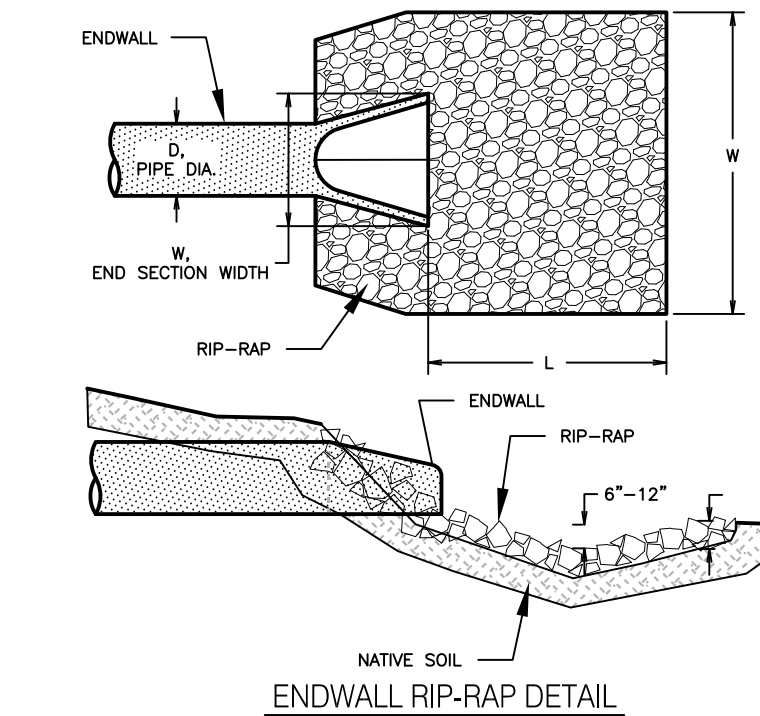

INLET PROTECTION TYPE "A"
FOR STRUCTURES S-5, S-7, S-9, AND S-12
FOR STRUCTURES S-16, AND S-17 UNTIL AREA IS PAVED

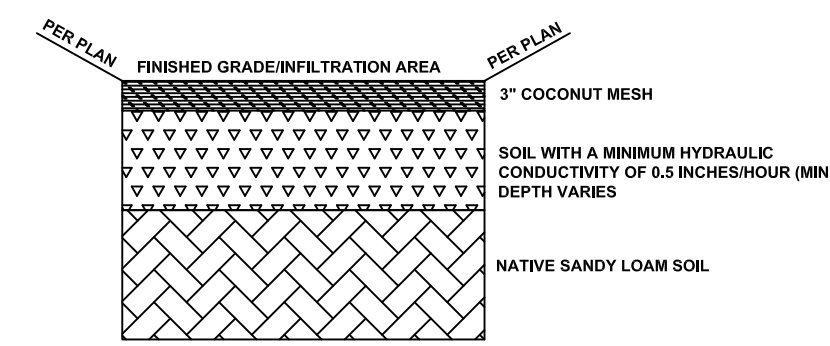

GENERAL NOTES:
1) CONTRACTOR TO EXCAVATE INFILTRATION BASIN AREAS UNTIL REACHING THE NATIVE SANDY LOAM LAYER. AREA OF CUT SHALL BE BACKFILLED WITH SANDY LOAM OR EQUIVALENT MATERIAL HAVING A HYDRAULIC CONDUCTIVITY RATE OF 0.5 IN/HR OR BETTER.
2) INFILTRATION AREA SHALL BE GRADED AND INSTALLED AFTER SITE DRAINING TO THE BASIN IS SECEDED AND VEGETATION IS ESTABLISHED.

INFILTRATION BASIN SOIL STRUCTURE DETAIL
FOR INFILTRATION BASINS 1 AND STORM BASIN 2 AND 3 INFILTRATION AREA

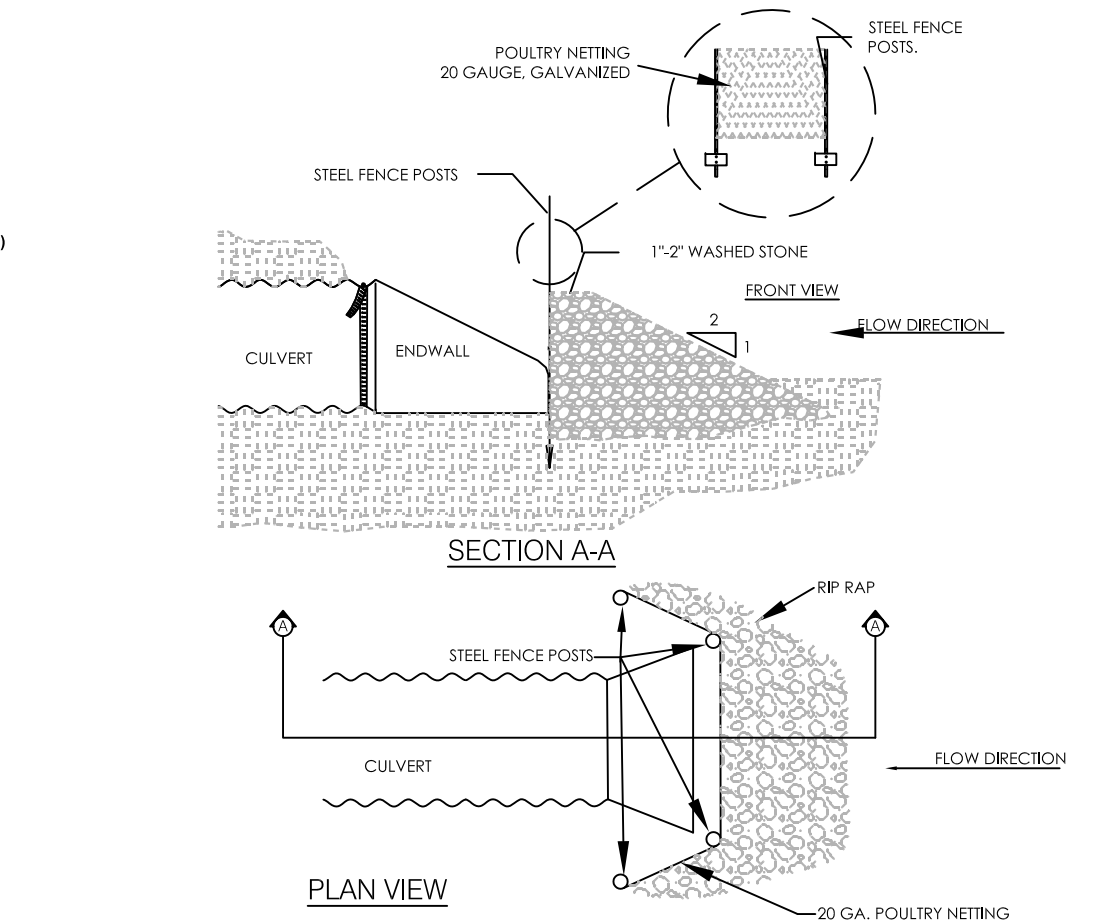

TEMPORARY STONE CULVERT PROTECTION
FOR STRUCTURES S-1, S-3, S-6, AND S-11
TO BE REMOVED ONCE UPSTREAM AREAS ARE STABILIZED AND GRASS IS ESTABLISHED

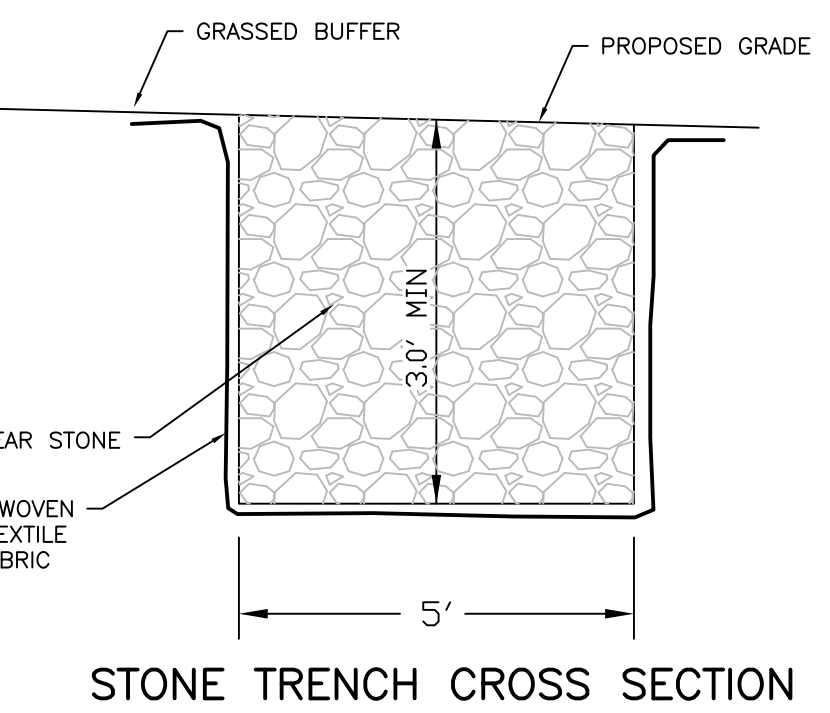

STONE TRENCH CROSS SECTION

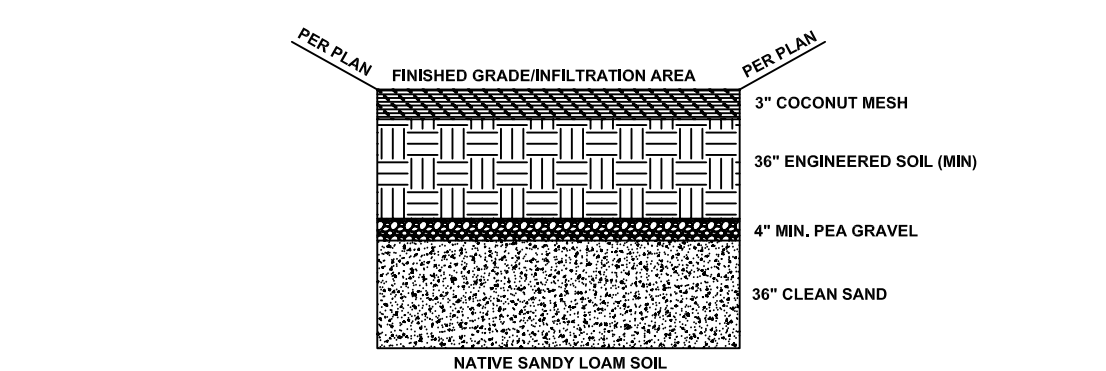

GENERAL NOTES:
1) ENGINEERED SOIL SHALL CONSIST OF 75-85% SAND AND 15-25% COMPOST BY VOLUME. SOILS BENEATH THE ABOVE SOIL STRUCTURE SHALL BE UNDERCUT AS NEEDED TO REACH A PERMEABLE LAYER.
2) INFILTRATION AREA SHALL BE GRADED AND INSTALLED AFTER SITE DRAINING TO THE BASIN IS SECEDED AND VEGETATION IS ESTABLISHED.
3) CONTRACTOR MUST EXCAVATE BASINS UNTIL REACHING THE SANDY LOAM SOIL LAYER. BACKFILL TO THE PEAS GRAVEL LAYER SHALL CONSIST OF CLEAN SAND.
4) MOISTURE TOLERANT PLANTS SHALL BE PLANTED IN THE BOTTOM OF BASIN SPACED ONE FOOT ON CENTER. PLUGS SHALL BE AGRI-CULT VET PRAIRIE SHORT STATURE MIX OR APPROVED EQUIVALENT.

BIORETENTION BASIN SOIL STRUCTURE DETAIL
FOR STORM BASIN 1 and BIORETENTION BASIN 1

NOTES:
SEE PLUMBING PLANS FOR SANITARY SEWER AND WATER MAIN DETAILS AND ELEVATIONS.

ALL STORM SEWER PIPING SHALL BE ADS, N-12 OR APPROVED EQUAL

LUDS LANE (DESIGN BY DANE COUNTY)

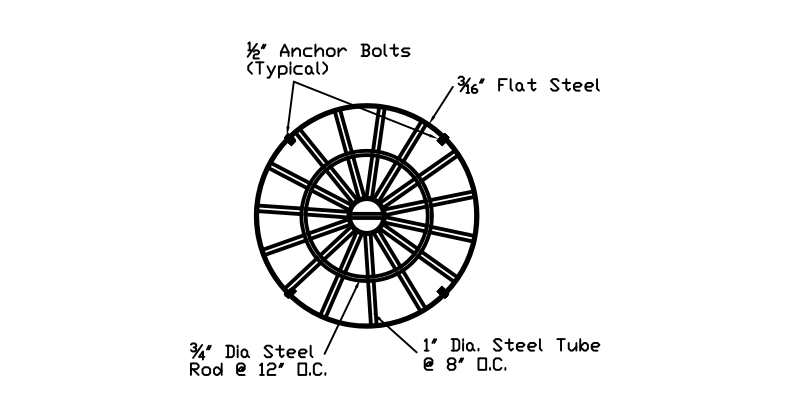
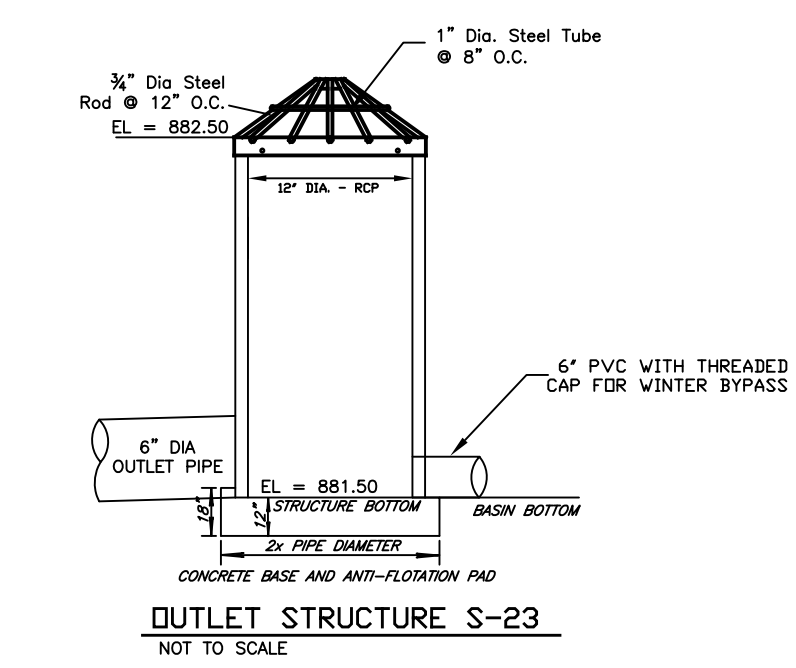
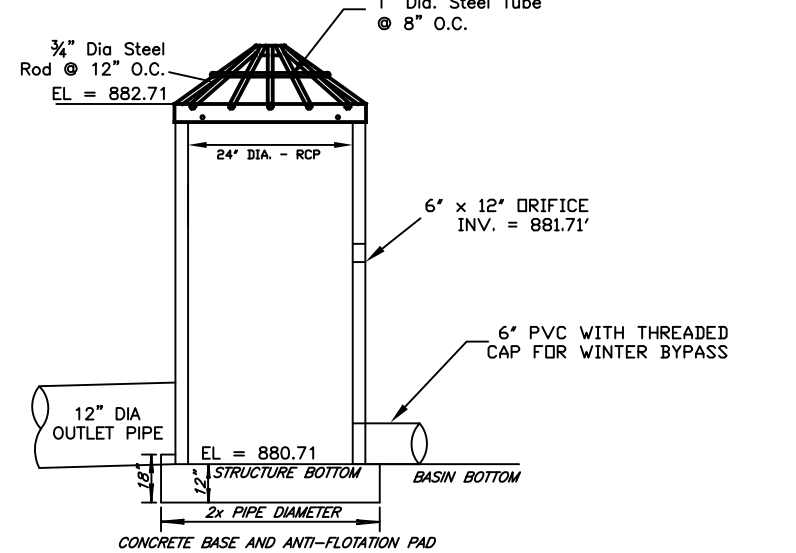
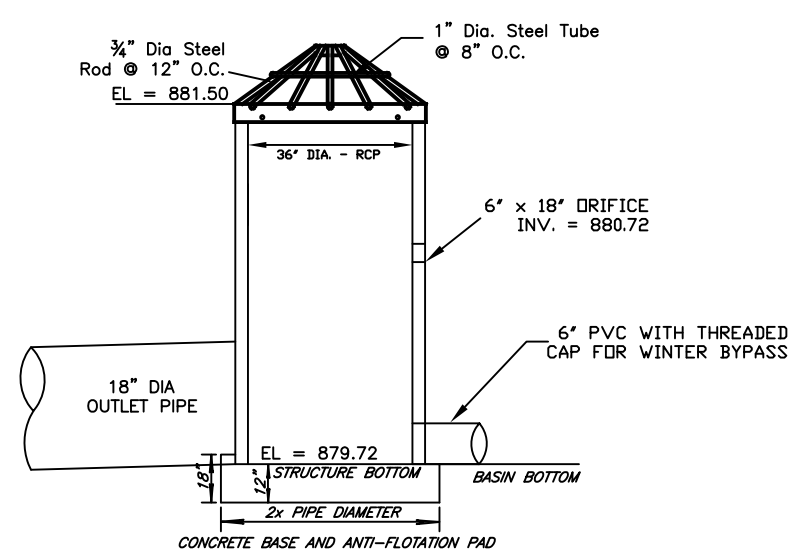
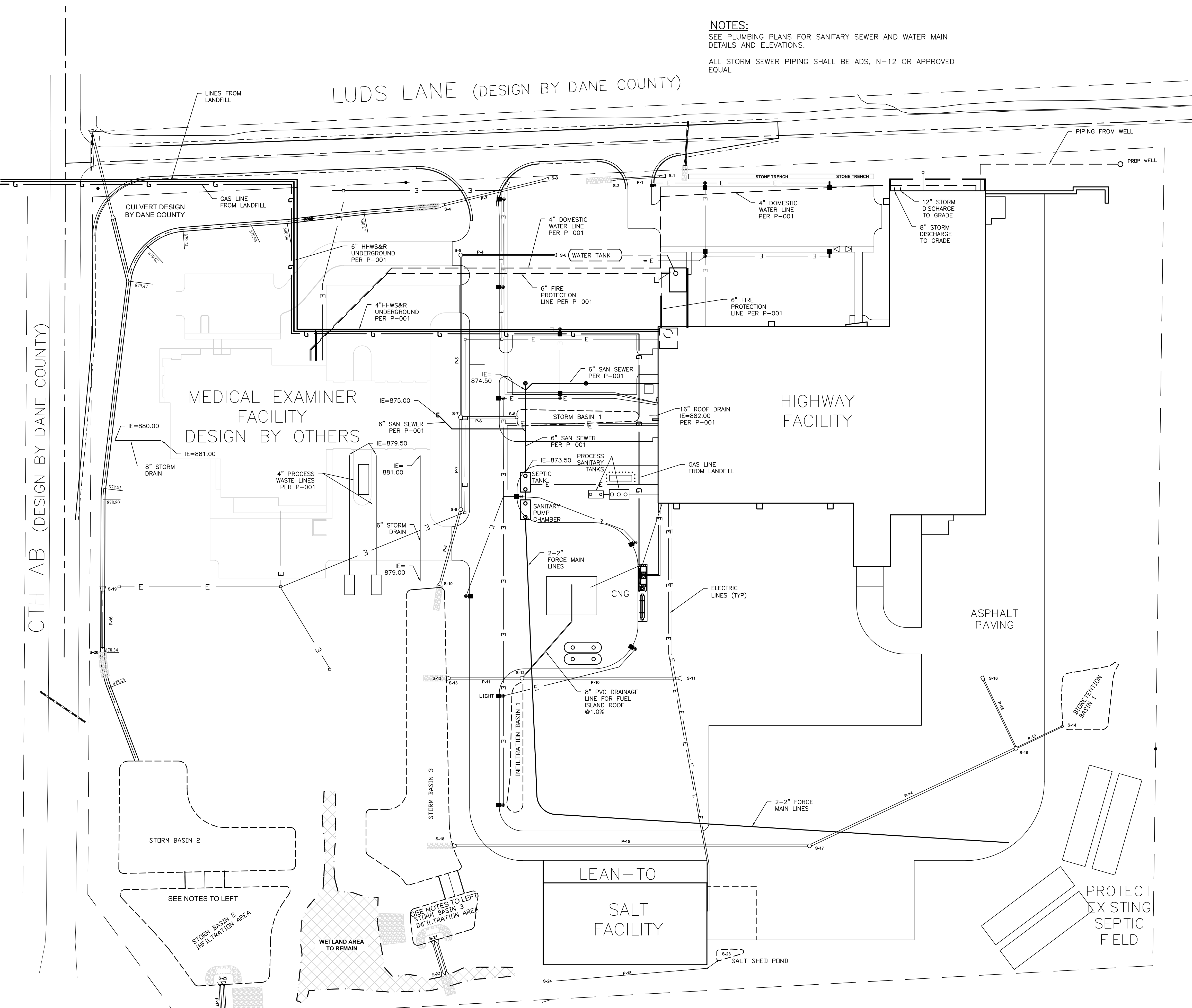

NOTES:

- EACH GRATE IS WIRE BRUSHED AND CLEANED THOROUGHLY PRIOR TO PAINTING
- EACH COAT IS AN OVERALL COAT EACH COAT IS ALLOWED TO DRY FOR 24 HOURS MIN.
- FIRST COAT: RUST-OLEUM X-60 RED BARE METAL PRIMER OR EQUAL
- SECOND COAT: RUST-OLEUM 960 ZINC CHROMATE PRIMER OR EQUAL
- THIRD COAT: RUST-OLEUM 1288 HIGH GLOSS AND METALLIC FINISH OR EQUAL
- GALVANIZED AND EPDY COATED GRATES ALSO AVAILABLE AS SPECIFIED

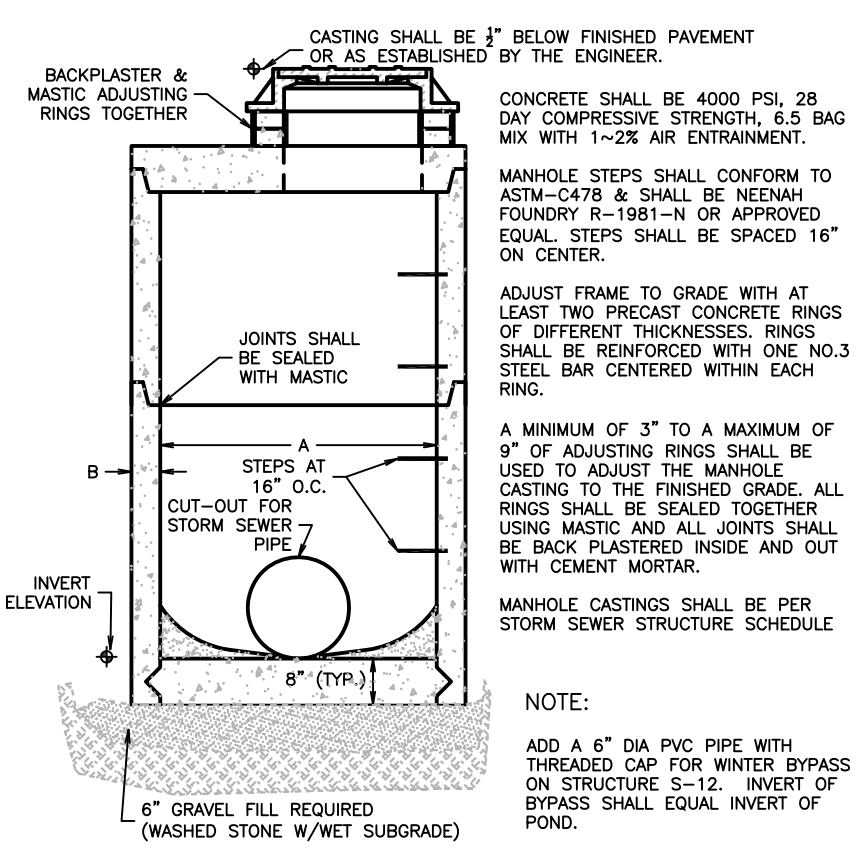

STORM MANHOLE DIMENSIONS

MANHOLE SIZE	A (MIN.)	B (MIN.)
48"	54"	54"
60"	66"	66"
72"	78"	78"
84"	90"	90"
96"	102"	102"

STORM SEWER STRUCTURE SCHEDULE

STRUCTURE NUMBER	TYPE	GRATE/LID TYPES	TOP OF CASTING	INVERT	DEPTH (FT)
S-1	24" APRON END WALL	N/A	881.20	N/A	N/A
S-2	24" APRON END WALL	N/A	881.03	N/A	N/A
S-3	24" APRON END WALL	N/A	880.84	N/A	N/A
S-4	24" APRON END WALL	N/A	880.50	N/A	N/A
S-5	48" DIA MANHOLE W/GRATE	R-1792-EG	883.70	879.32	4.38
S-6	12" APRON END WALL	N/A	881.10	N/A	N/A
S-7	60" DIA MANHOLE W/GRATE	R-1792-EG	882.00	878.47	3.53
S-8	STORM BASIN 1 OUTFALL	N/A	879.72	N/A	N/A
S-9	48" DIA MANHOLE W/GRATE	R-1792-EG	881.40	877.98	3.42
S-10	24" APRON END WALL	N/A	877.59	N/A	N/A
S-11	24" APRON END WALL	N/A	876.43	N/A	N/A
S-12	48" DIA MANHOLE W/GRATE	R-1792-EG	889.61	877.61	3.80
S-13	24" APRON END WALL	N/A	877.20	N/A	N/A
S-14	INFILTRATION BASIN 1 OUTFALL	N/A	880.71	880.71	N/A
S-15	48" DIA MANHOLE	R-1689	884.00	880.28	3.72
S-16	2" x 3" H/LET W/GRATE	R-3403-F	883.21	880.69	2.52
S-17	48" DIA MANHOLE W/GRATE	R-1792-EG	882.60	879.08	3.52
S-18	24" APRON END WALL	N/A	877.20	N/A	N/A
S-19	36" APRON END WALL	N/A	876.54	N/A	N/A
S-20	36" APRON END WALL	N/A	876.34	N/A	N/A
S-21	2 x 18" APRON END WALLS	N/A	877.20	N/A	N/A
S-22	2 x 18" APRON END WALLS	N/A	877.10	N/A	N/A
S-23	SALT SHED POND OUTFALL	N/A	882.80	881.50	N/A
S-24	SALT SHED POND OUTFALL	N/A	880.64	N/A	N/A
S-25	2 x 12" APRON END WALLS	N/A	877.20	N/A	N/A
S-26	2 x 12" APRON END WALLS	N/A	877.10	N/A	N/A

STORM SEWER PIPE SCHEDULE

PIPE NUMBER	FROM (UPSTREAM)	TO (DOWNSTREAM)	LENGTH (FT)	INLET INVERT (FT)	DISCHARGE INVERT (FT)	SLOPE (%)	DIAMETER OF PIPE (IN)
P-1	S-1	S-2	55.27	881.20	881.03	0.30	24
P-2	S-3	S-4	114.82	880.84	880.50	0.30	24
P-3	N/A	N/A	N/A	N/A	N/A	N/A	N/A
P-4	S-6	S-5	97.14	881.10	879.32	1.83	12
P-5	S-5	S-7	164.26	879.32	878.47	0.52	12
P-6	S-8	S-7	56.53	879.72	878.47	2.21	18
P-7	S-7	S-9	93.50	878.47	877.98	0.52	24
P-8	S-9	S-10	79.84	877.98	877.59	0.49	24
P-9	S-11	S-12	162.00	876.43	877.61	0.52	24
P-10	S-12	S-13	76.61	877.61	877.20	0.54	24
P-11	S-14	S-15	51.85	880.71	880.28	0.83	12
P-12	S-16	S-15	78.52	880.69	880.28	0.52	12
P-13	S-15	S-17	231.15	880.28	879.08	0.52	24
P-14	S-17	S-18	361.10	879.08	877.20	0.52	24
P-15	S-19	S-20	67.00	878.54	878.34	0.30	36
P-16	S-19	S-20	45.00	877.20	877.10	0.22	2 x 12
P-17	S-23	S-24	166.10	881.50	880.64	0.52	6

ALL DISTANCES ARE FROM CENTERLINE TO CENTERLINE OF STRUCTURES OR FROM CENTERLINE OF STRUCTURE TO END OF APRON ENDWALL

NOTES:

INSTALL TWO (2) 12" x 20" HDPE PIPES. COVER NORTH END WITH 1" CLEAR STONE AND INSTALL A REMOVABLE CAP AT SOUTH END.

INSTALL A 6" x 20" HDPE PIPE COVER BOTH ENDS WITH 3" CLEAR STONE

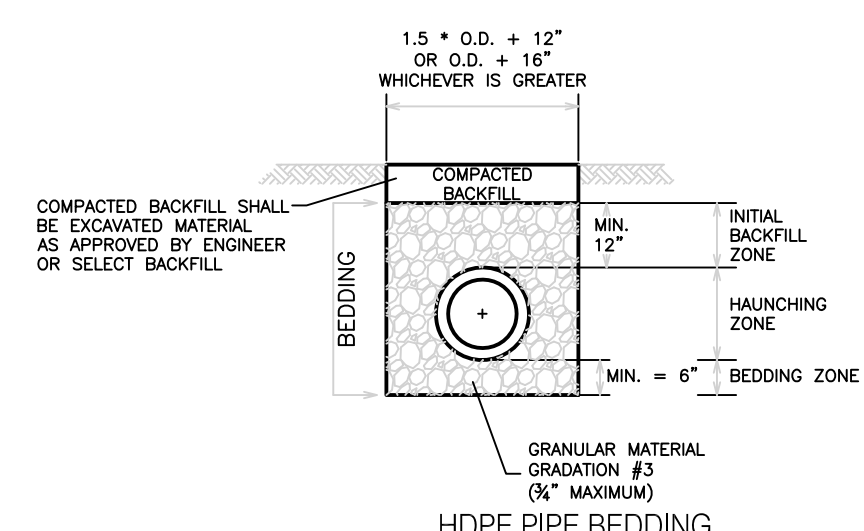

NOTES:

UNLESS OTHERWISE SPECIFIED, ALL HDPE SEWER PIPES, INCLUDING LATERALS AND LEADS, SHALL BE INSTALLED WITH THE TYPE OF BEDDING SHOWN FOR THE TYPE AND SIZE OF PIPE INSTALLED.

ALL TRENCHES SHALL BE HAND BACKFILLED TO A POINT 12" ABOVE THE TOP OF THE PIPE. ALL BEDDING SHALL BE MECHANICALLY COMPACTED.

THE MAXIMUM ALLOWABLE TRENCH WIDTH SHALL BE THE MIN. SPECIFIED PLUS 12". AND SHALL APPLY FROM THE BOTTOM OF THE TRENCH TO A POINT 12" ABOVE THE TOP OF PIPE. WHERE THIS WIDTH IS EXCEEDED, THE CONTRACTOR SHALL FURNISH AND INSTALL A HIGHER TYPE OF BEDDING AT NO EXTRA COST. THE TYPE OF BEDDING SHALL BE DETERMINED BY THE ENGINEER.

O.D. EQUALS THE OUTSIDE DIAMETER OF THE PIPE.

LUDS LANE (DESIGN BY DANE COUNTY)

CTH AB (DESIGN BY DANE COUNTY)

MEDICAL EXAMINER FACILITY
DESIGN BY OTHERS

HIGHWAY FACILITY

FUEL ISLAND
54"x42"
CONCRETE PAD

CNG

ASPHALT PAVING

CONCRETE PAD
SALT FACILITY FLOOR SHALL BE PAVED WITH ASPHALT

LEAN-TO
SALT FACILITY

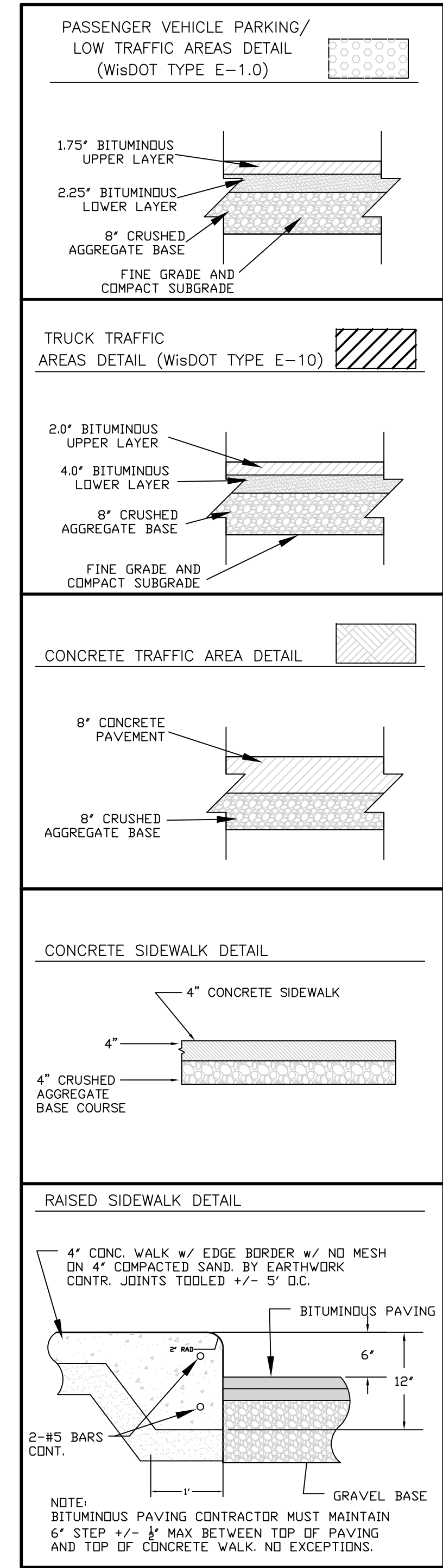

LUDS LANE (DESIGN BY DANE COUNTY)

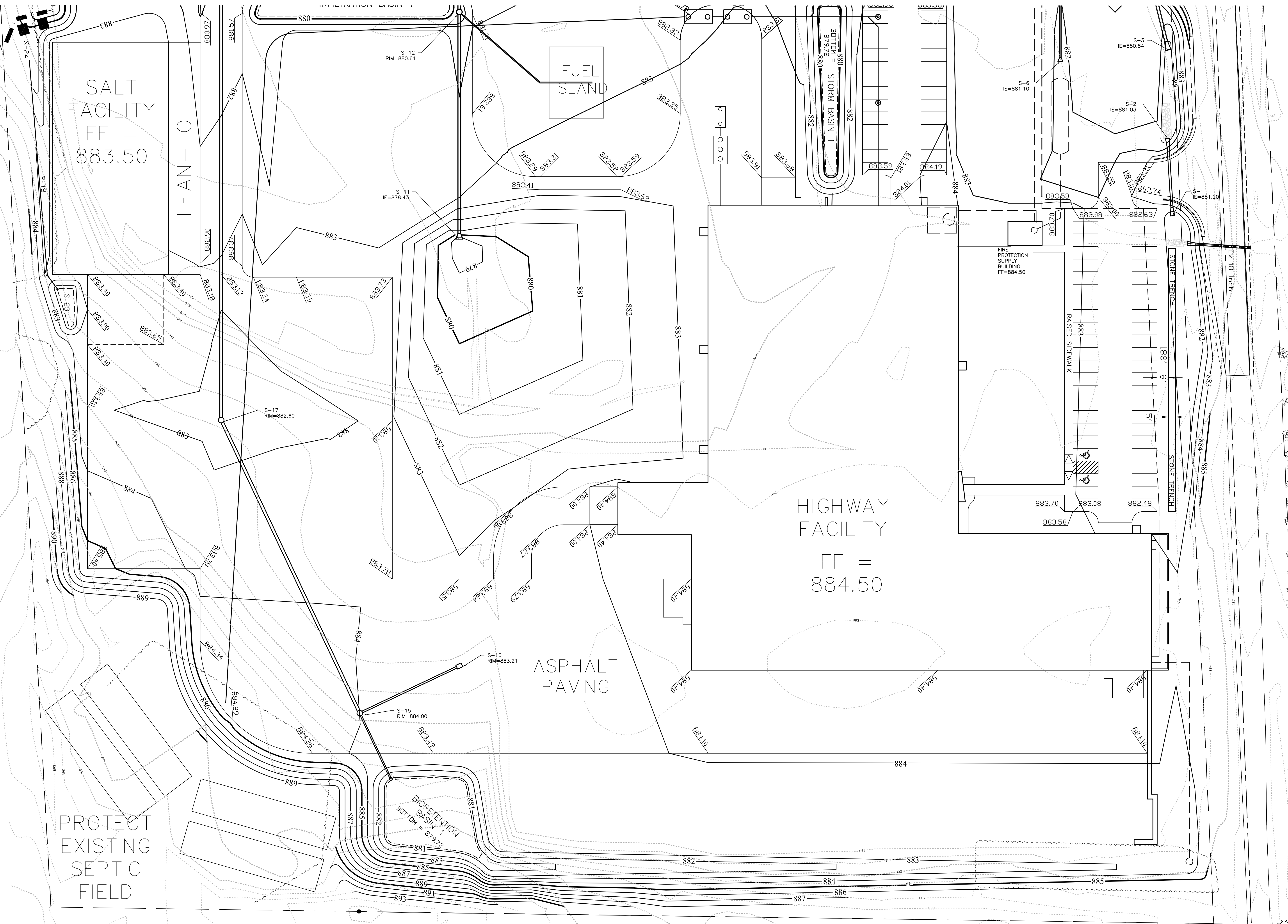

PLAN NORTH
SCALE: 1"=30'

Phase 1 Grading Plan
 kuenyarch.com ©2013 Kueny Architects L.L.C. - All Rights Reserved
 Dane County - Dane County Highway Facility
 3562 County Highway AB, Cottage Grove, WI 53558
 JANUARY 12, 2015

S SNYDER & ASSOCIATES, INC.
 5010 VOIGES ROAD
 MADISON, WISCONSIN 53718
 608-838-0444 | www.snyder-associates.com

C-106

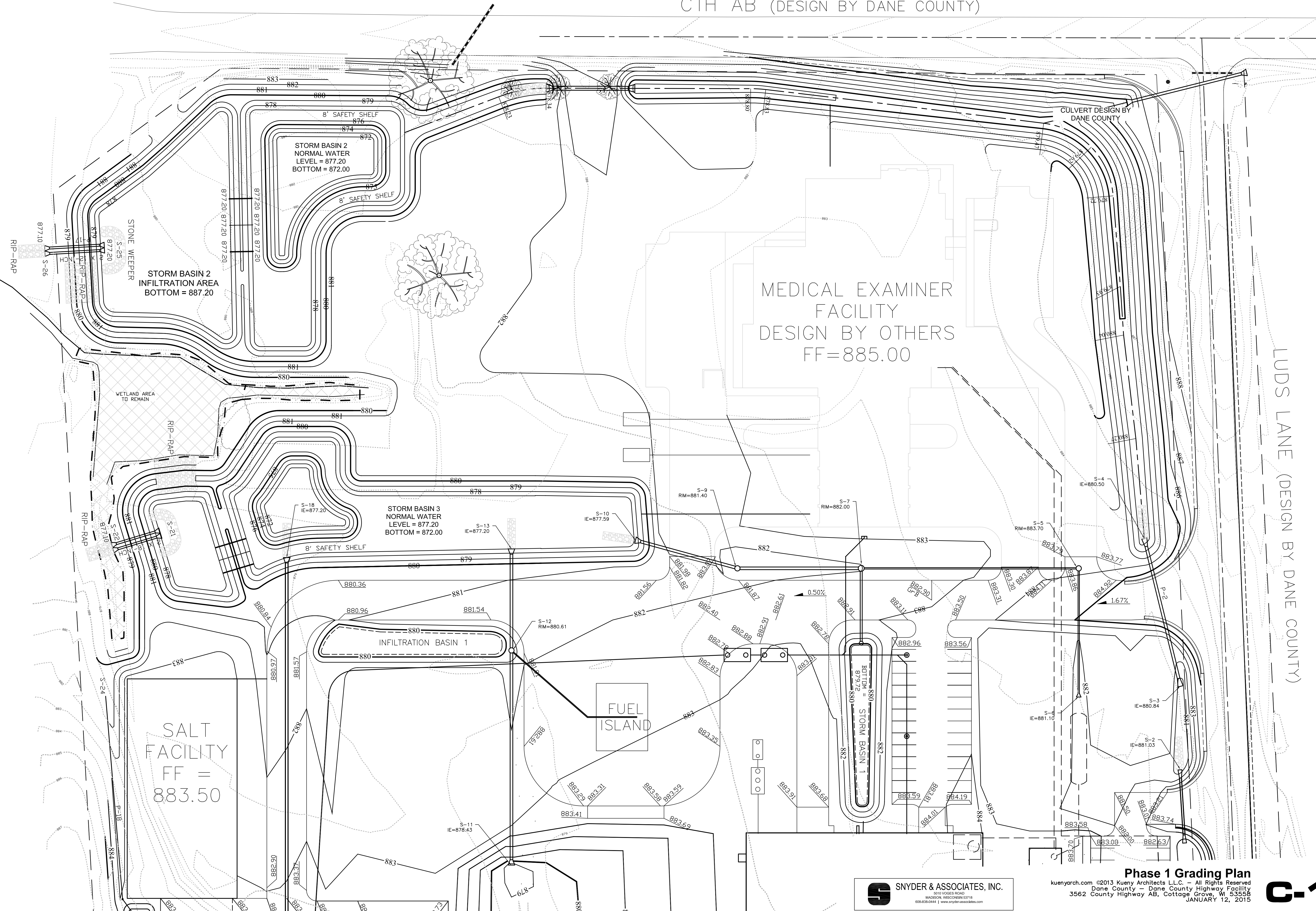

LUDS LANE (DESIGN BY DANE COUNTY)

PLAN NORTH
SCALE: 1"=30'

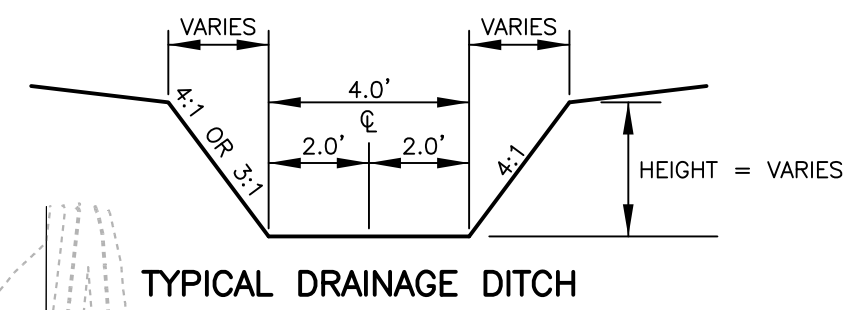

LUDS LANE (DESIGN BY DANE COUNTY)

CTH AB (DESIGN BY DANE COUNTY)

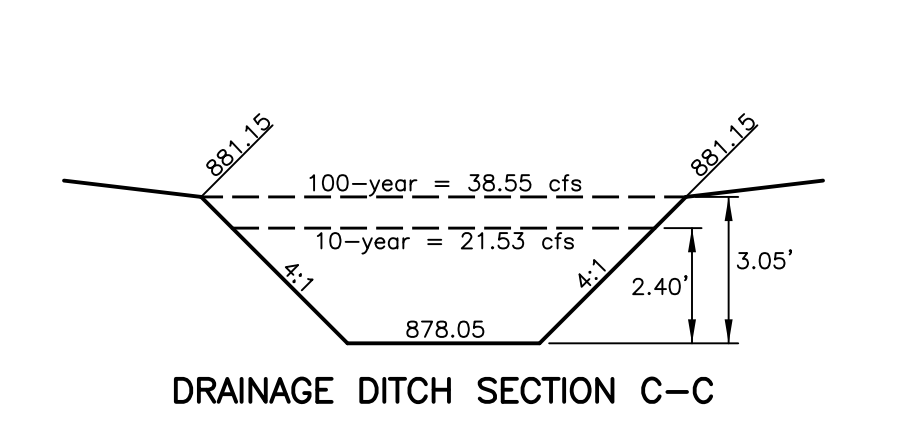
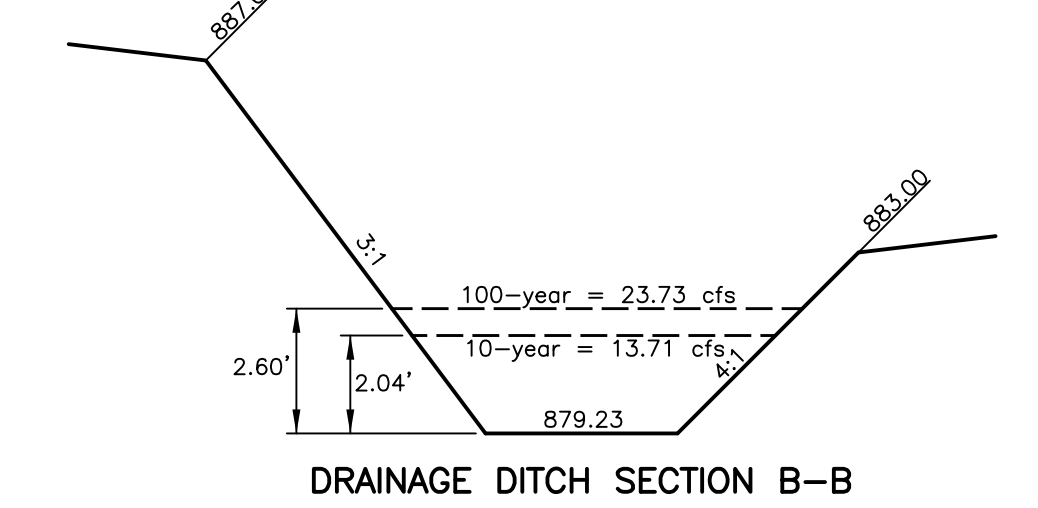
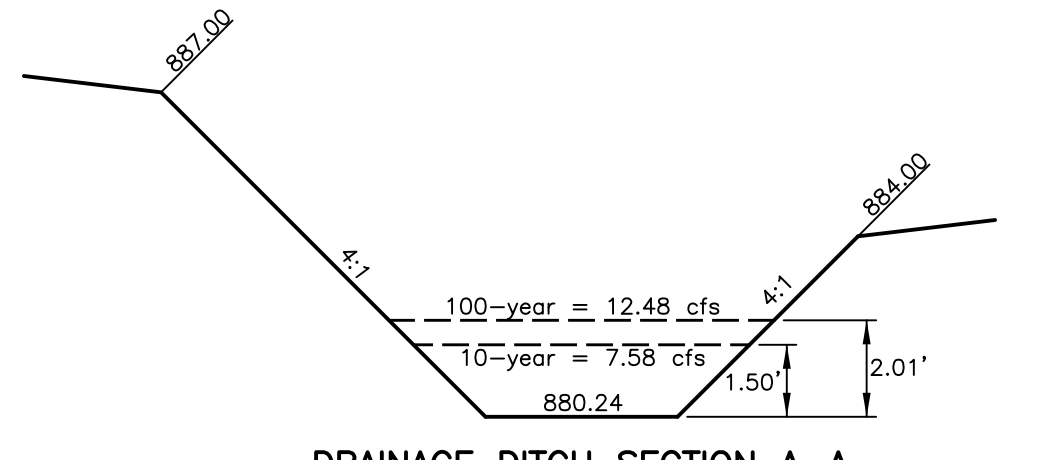
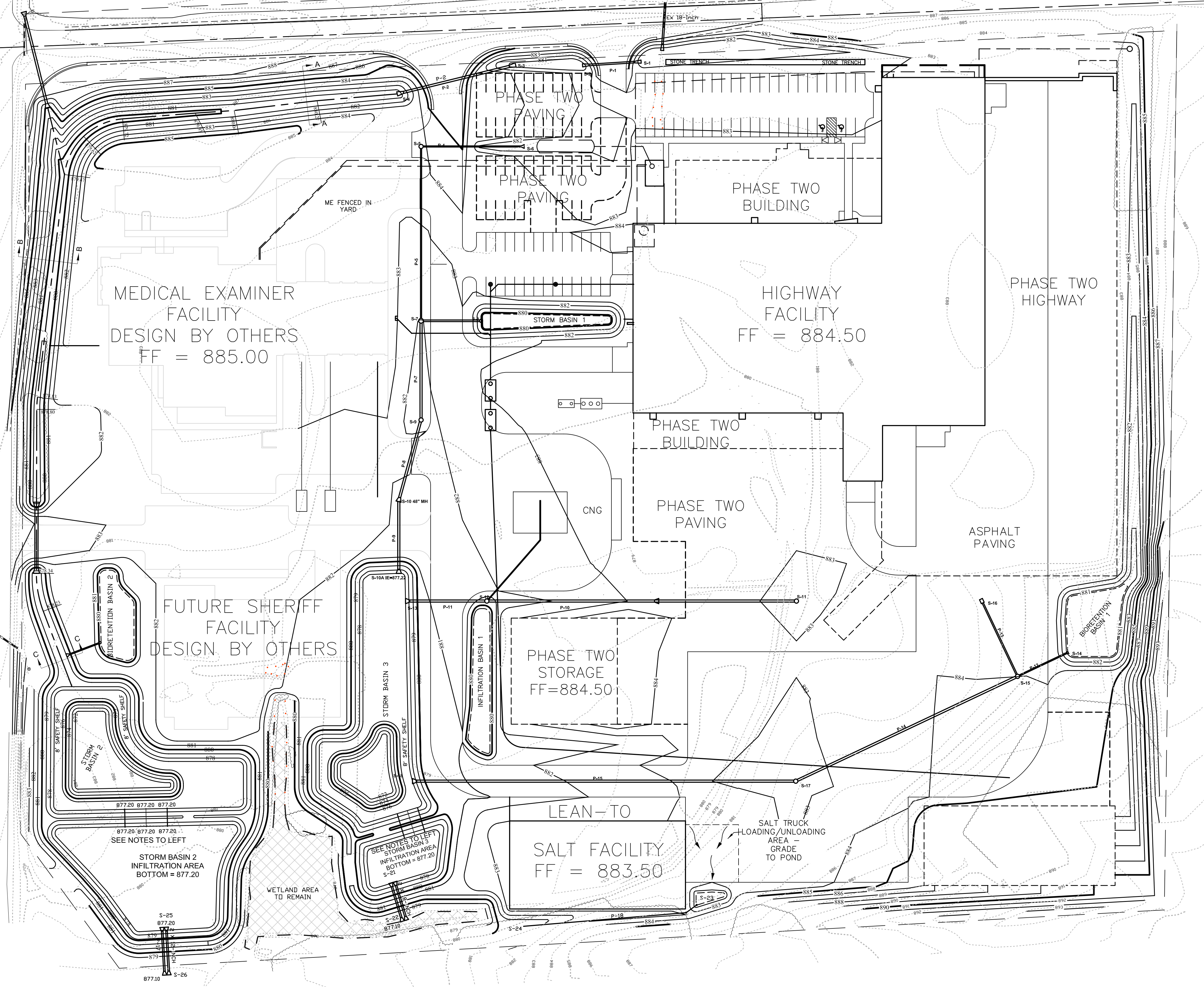

NOTES:
 1) INSTALL TWO (2) 12" x 20' HDPE PIPES. COVER NORTH END WITH 3" CLEAR STONE AND INSTALL A REMOVABLE CAP AT SOUTH END.
 2) INSTALL A 6" x 20' HDPE PIPE COVER BOTH ENDS WITH 3" CLEAR STONE.

SEE NOTES TO LEFT

SEE NOTES TO LEFT

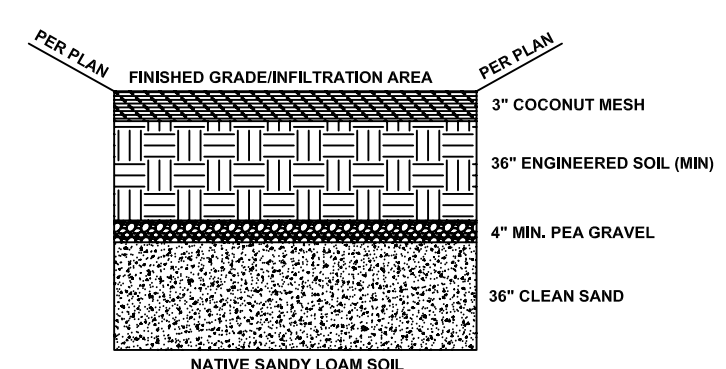

GENERAL NOTES:
 1) ENGINEERED SOIL SHALL CONSIST OF 75-85% SAND AND 15-25% COMPOST BY VOLUME. SOILS BENEATH THE ABOVE SOIL STRUCTURE SHALL BE UNDERCUT AS NEEDED TO REACH A PERMEABLE LAYER.
 2) INFILTRATION AREA SHALL BE GRADED AND INSTALLED AFTER SITE DRAINING TO THE BASIN IS SEEDING AND VEGETATION IS ESTABLISHED.
 3) CONTRACTOR MUST EXCAVATE BASINS UNTIL REACHING THE SANDY LOAM SOIL LAYER. BACKFILL TO THE PEA GRAVEL LAYER SHALL CONSIST OF CLEAN SAND.
 4) MOISTURE TOLERANT PLANTS SHALL BE PLANTED IN THE BOTTOM OF BASIN SPACED ONE FOOT ON CENTER. PLUGS SHALL BE AGRICULTURAL VET PRAIRIE SHORT STATURE MIX OR APPROVED EQUIVALENT.



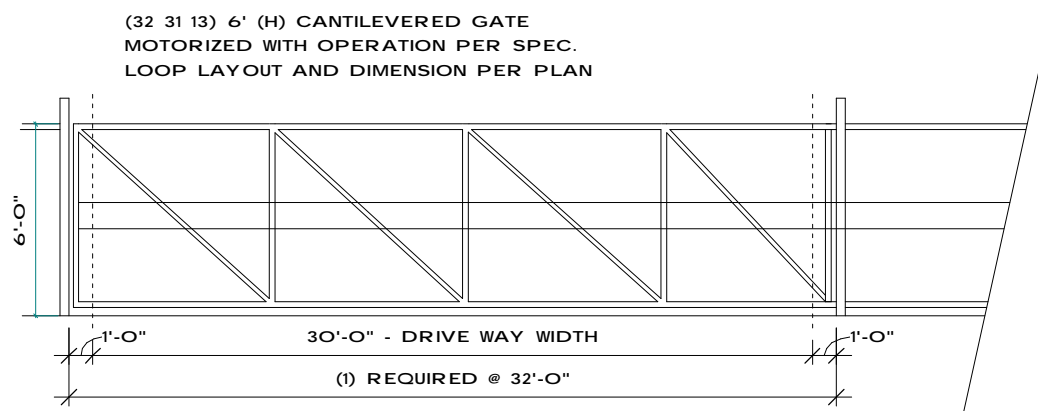

2 Cantilever Gate Detail
1/8" = 1'-0"

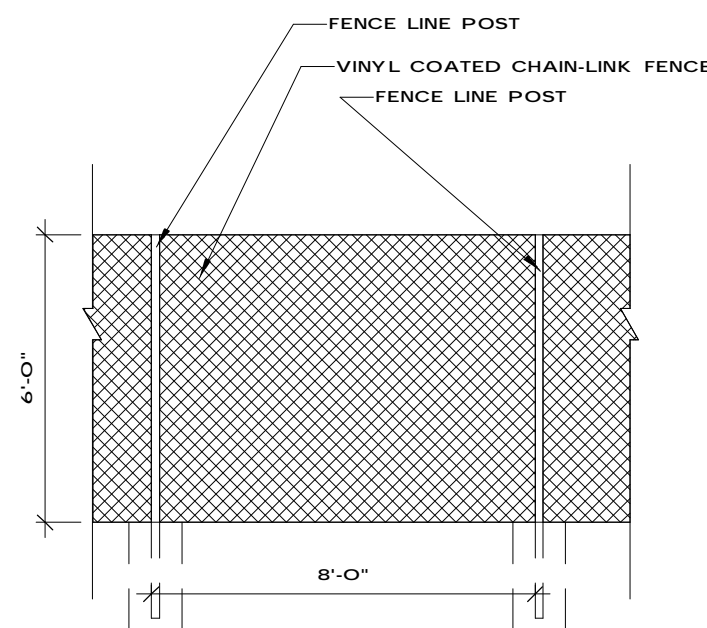

3 Typ. Fence Section - Elevation
1/4" = 1'-0"

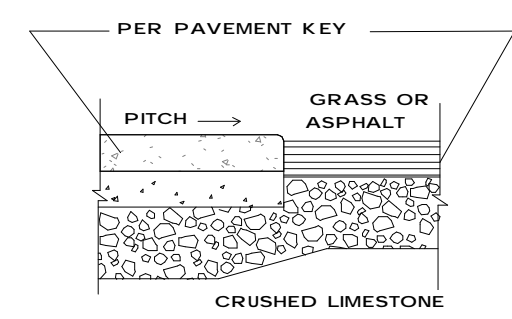

Asphalt @ Concrete

4 Typical Site Edges - Asphalt @ Concrete
3/4" = 1'-0"

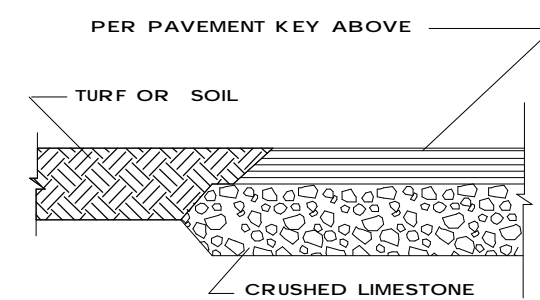

Asphalt @ Topsoil

5 Typical Site Edges - Asphalt @ Topsoil
3/4" = 1'-0"

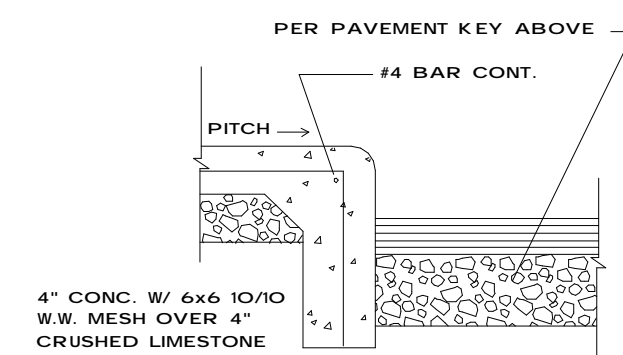

Walk @ Asphalt

6 Typical Site Edges - Walk @ Asphalt
3/4" = 1'-0"

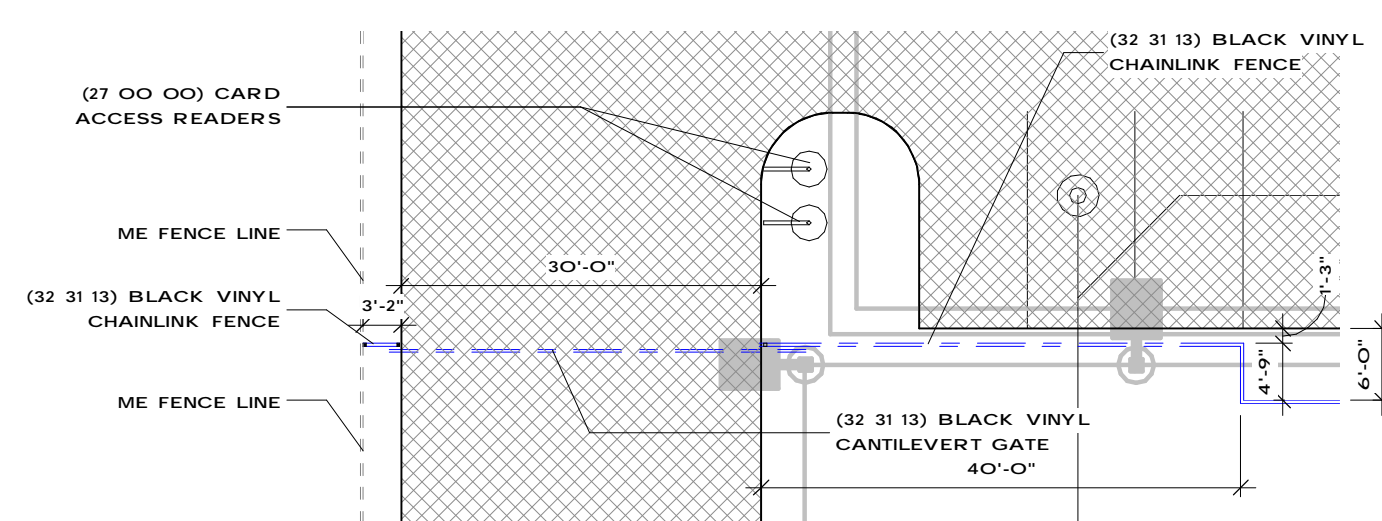

7 Gate Enlarged Plan
1/16" = 1'-0"

1 Master Site Plan - Phases 1
1" = 50'-0"

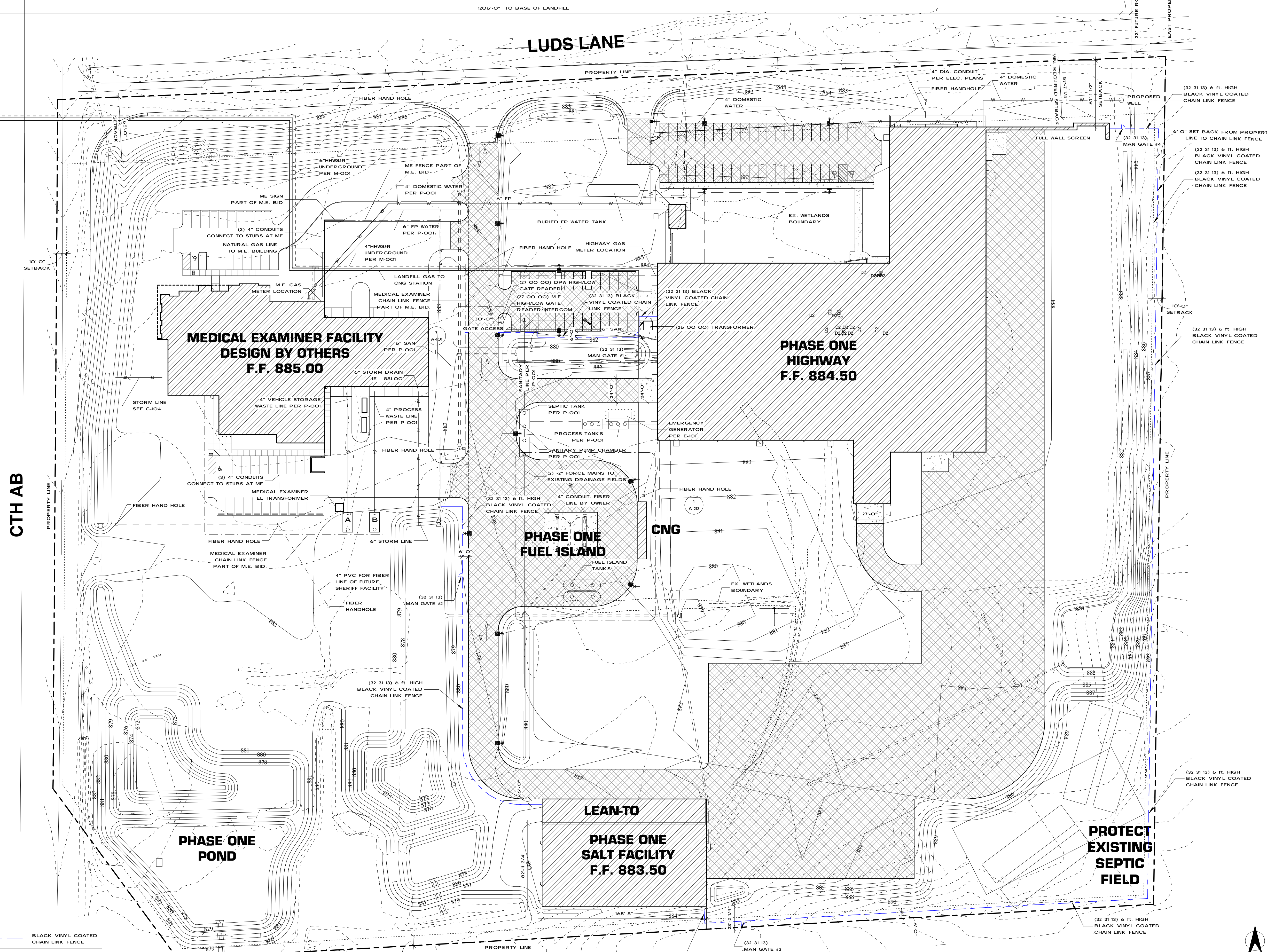

--- BLACK VINYL COATED CHAIN LINK FENCE

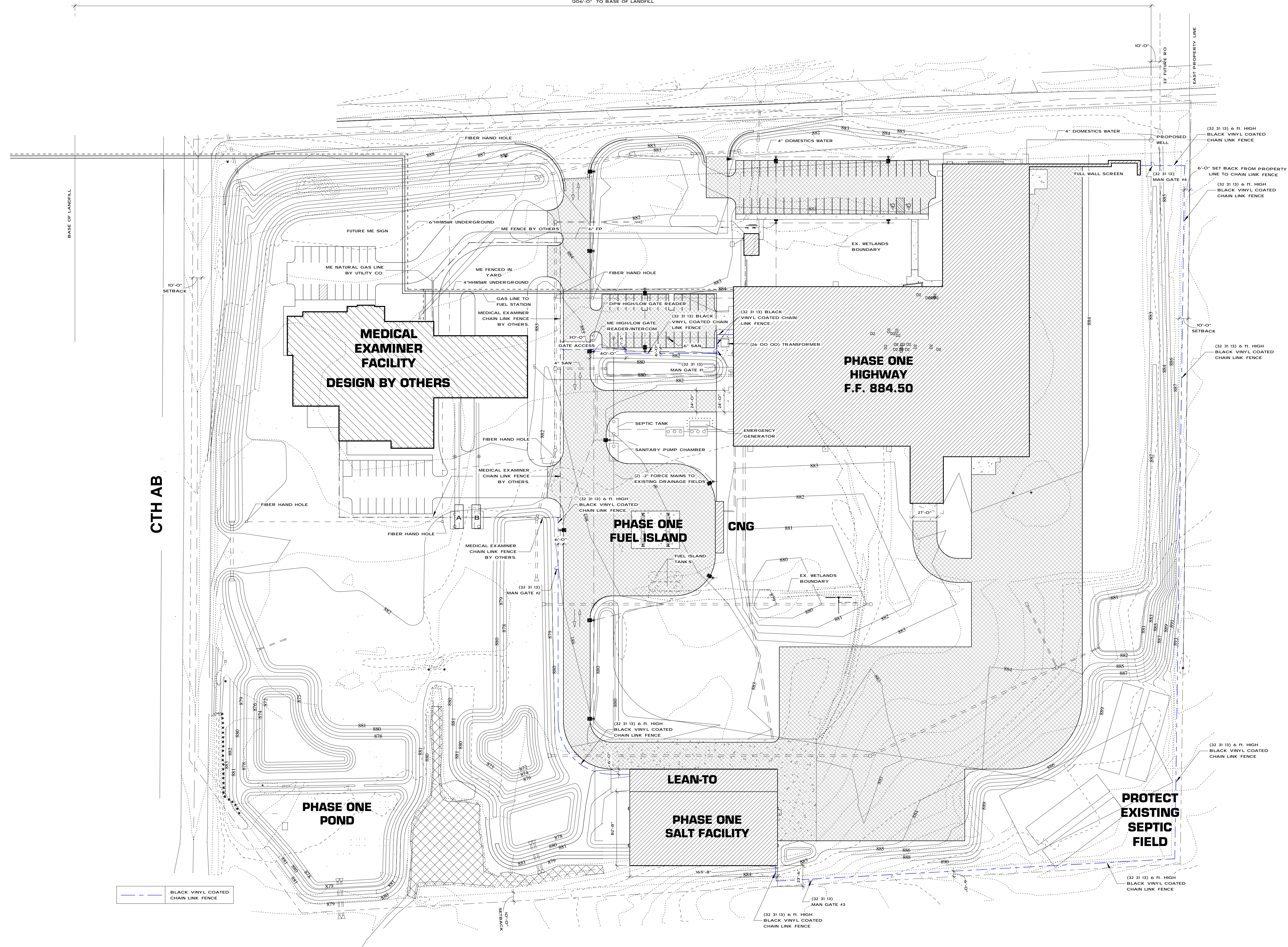

CTH AB

 32 31 13 6 ft. HIGH BLACK VINYL COATED CHAIN LINK FENCE
 10'-0" SETBACK

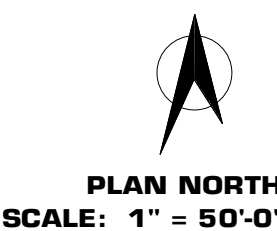

CTH AB

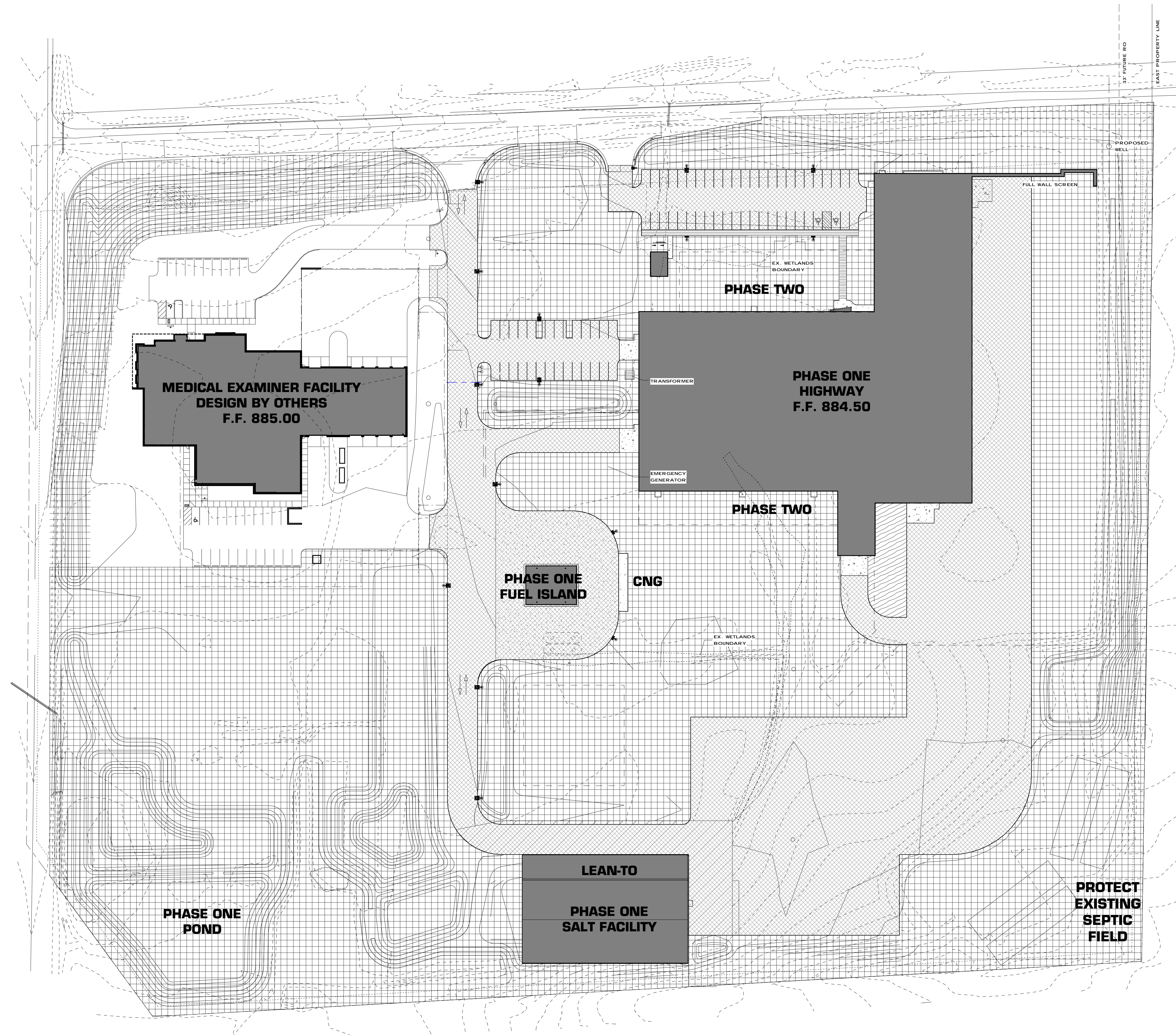

SYMBOLOLOGY	
	SEEDED/ LANDSCAPE AREA
	NEW BUILDINGS
	PAVED AREA
	CONCRETE AREA
	NEW STONE AREA
	SITE WORK BY OTHERS

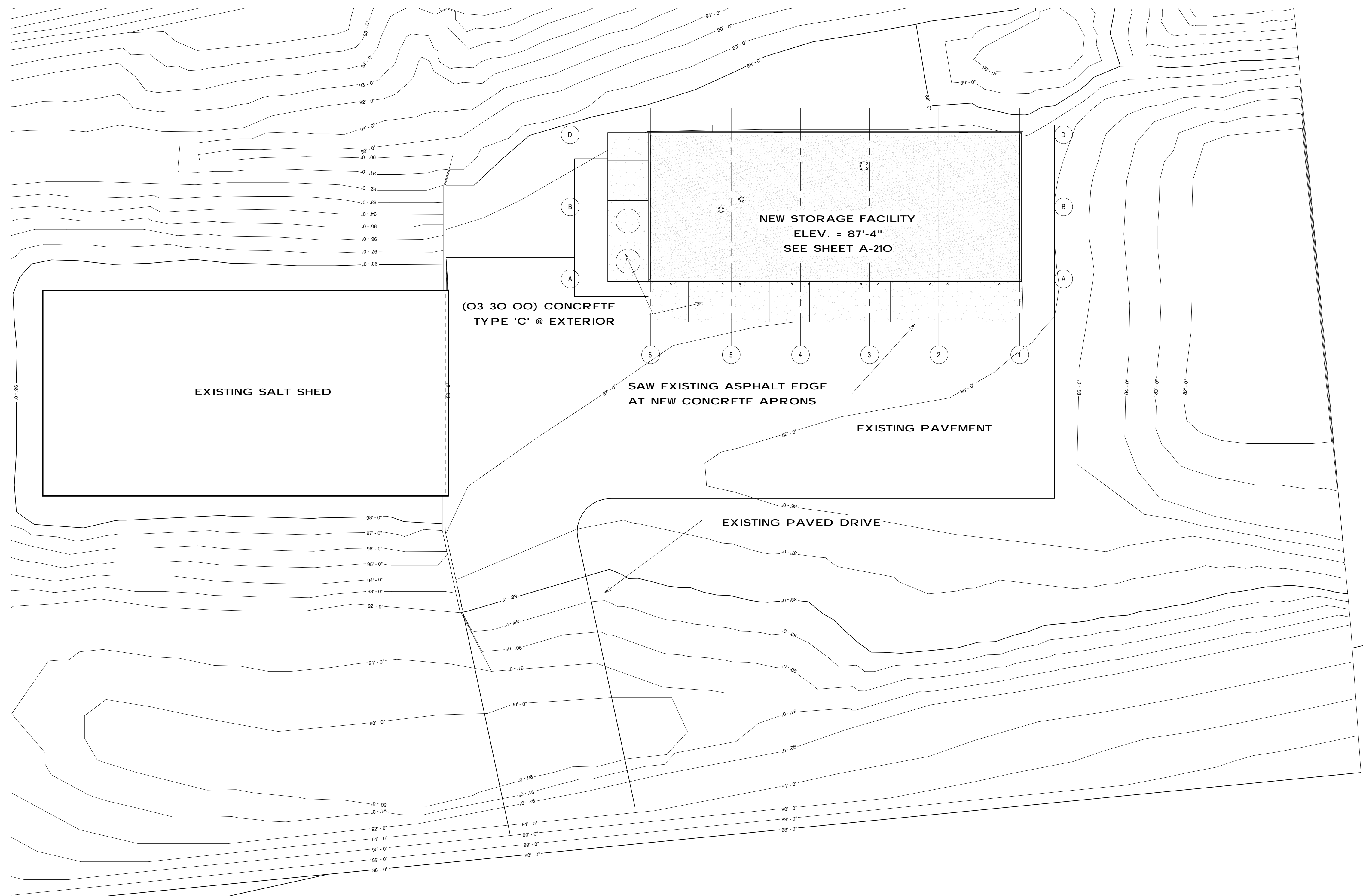

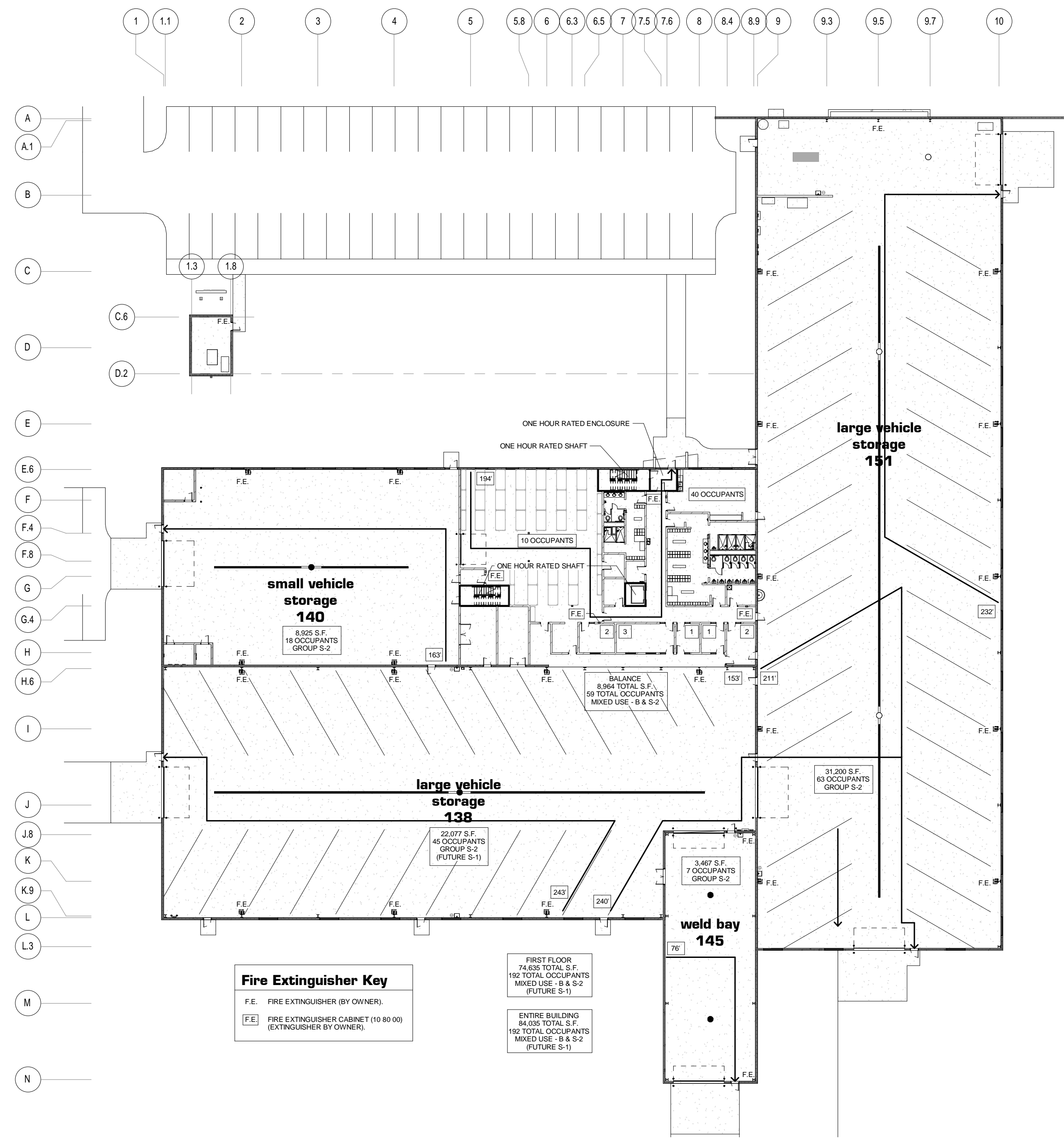

Code Summary

SECTION	REMARKS
311.3	OCCUPANCY CLASS = S-2 - VEHICLE STORAGE (FUTURE = S-1 - VEHICLE MAINTENANCE @ ROOM 138)
503.1	TABULAR ALLOWABLE AREA = 26,000 S.F.
505.2	SECOND LEVEL DOES NOT QUALIFY AS A MEZZANINE BY AREA
506.1	MODIFIED ALLOWABLE AREA = 97,500 S.F.
506.2	FRONTAGE AREA INCREASE = 75%
506.3	SPRINKLER AREA INCREASE = 200%
	ACTUAL AREA = 74,635 S.F. < 97,500 S.F.
507.4	UNLIMITED AREA - 2-STORY (FUTURE PHASE II)
	60' PUBLIC WAY OR YARD - 40' AT EAST SIDE. FUTURE WALLS TO BE 3 HOUR RATED PER 507.5
	OCCUPANCY GROUP S-2 - 3-STORY MAXIMUM OCCUPANCY GROUP S-1 - 2-STORY MAXIMUM
508.3	FUTURE OCCUPANCY GROUP B & S-1 - UNSEPARATED MIXED USE
602.1	CONSTRUCTION CLASS = TYPE IIB
602.1	FIRE SEPARATION DISTANCE = >30' -- EXTERIOR WALLS = 0 HOUR
705.8	FIRE SEPARATION DISTANCE = >30' -- OPENINGS UNPROTECTED
708.2	SHAFT ENCLOSURES 1 HOUR RATED @ STAIR 128 & STAIR 133 EXCEPTION #7 APPLIES @ OPENING FROM ROOM 201 TO ROOM 138
708.14	ELEVATOR HOISTWAY - 1 HOUR RATED SHAFT
715.4	DOORS @ STAIR 128 & STAIR 133 - 1 HOUR RATED
903.2.10	GROUP S-2 FIRE AREA EXCEEDS 12,000 S.F. - FIRE PROTECTION IS BEING INSTALLED. (903.2.9 @ FUTURE GROUP S-1)
906.3	FIRE EXTINGUISHER DISTRIBUTION - EVERY 11,250 S.F. / 75 FOOT TRAVEL DISTANCE

SECTION	REMARKS
1004.1	OCCUPANT LOAD AS SHOWN ON PLANS VEHICLE STORAGE = 500 S.F. / OCCUPANT (GROSS) MEZZANINE & PARTS = 300 S.F. / OCCUPANT (GROSS) OFFICE = 100 S.F. / OCCUPANT (GROSS) LOCKER ROOM = 50 S.F. / OCCUPANT (GROSS) UNCONCENTRATED ASSEMBLY = 15 S.F. / OCCUPANT (NET)
1005.1	EGRESS WIDTH (REQUIRED / PROVIDED) = MEZZANINE (SECOND FLOOR) = 7' / 72" LARGE VEHICLE STORAGE 138 = 9' / 144" SMALL VEHICLE STORAGE 140 = 8' / 72" WELD BAY 145 = 2' / 36" LARGE VEHICLE STORAGE 151 = 13' / 108" BALANCE (LOCKER / OFFICE / MISC.) = 16' / 108"
1008.1.2	DOORS SWING IN DIRECTION OF EGRESS @ ROOM 151 & BALANCE.
1008.1.10	PANIC HARDWARE IS NOT REQUIRED.
1009.1	EXCEPTION #1 - STAIRWAY MINIMUM WIDTH = 36"
1014.3	COMMON PATH OF TRAVEL = 100' (EXCEPTION #1).
1015.1	TWO EXITS ARE PROVIDED AS REQUIRED.
1015.2.1	EXITS ARE SEPARATED BY A DISTANCE > 1/3 DIAGONAL DIMENSION.
1016.1	EXIT TRAVEL DISTANCE LIMIT - SEE PLAN 250' @ OCCUPANCY GROUP S-1 (FUTURE) 300' @ OCCUPANCY GROUP S-2 400' @ OCCUPANCY GROUP S-2
1022.1	INTERIOR STAIRWAYS = 1 - HOUR RATED. STAIR 133 EXITS TO THE EXTERIOR.
1027.1	STAIR 128 QUALIFIES FOR EXCEPTION #1.
2902.1	PLUMBING FIXTURE COUNTS: WATER CLOSETS - REQUIRED = 3 PROVIDED = 14 LAVATORIES - REQUIRED = 3 PROVIDED = 6 DRINKING FOUNTAIN - REQUIRED = 1 PROVIDED = 1 SERVICE SINK - REQUIRED = 1 PROVIDED = 1

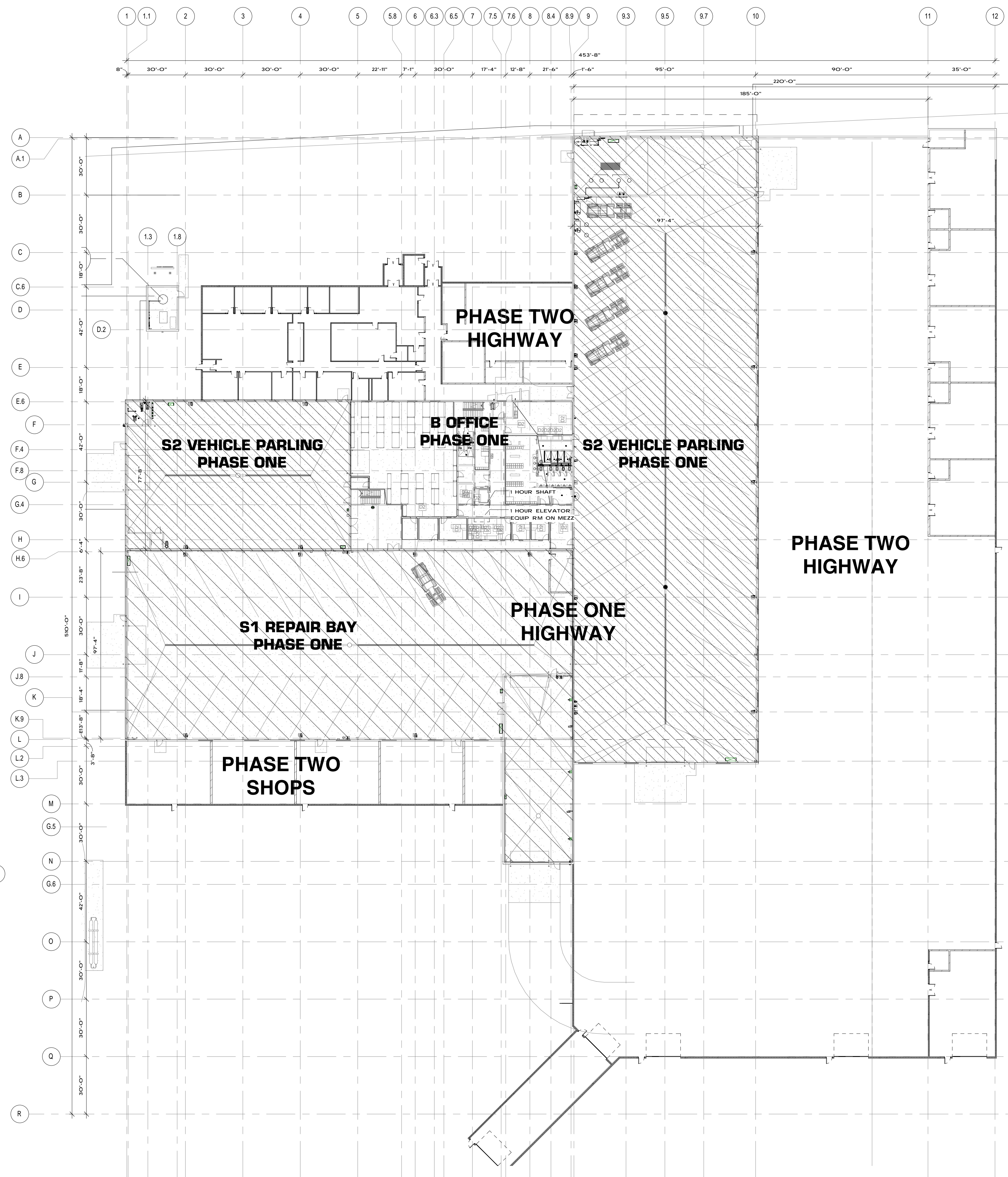
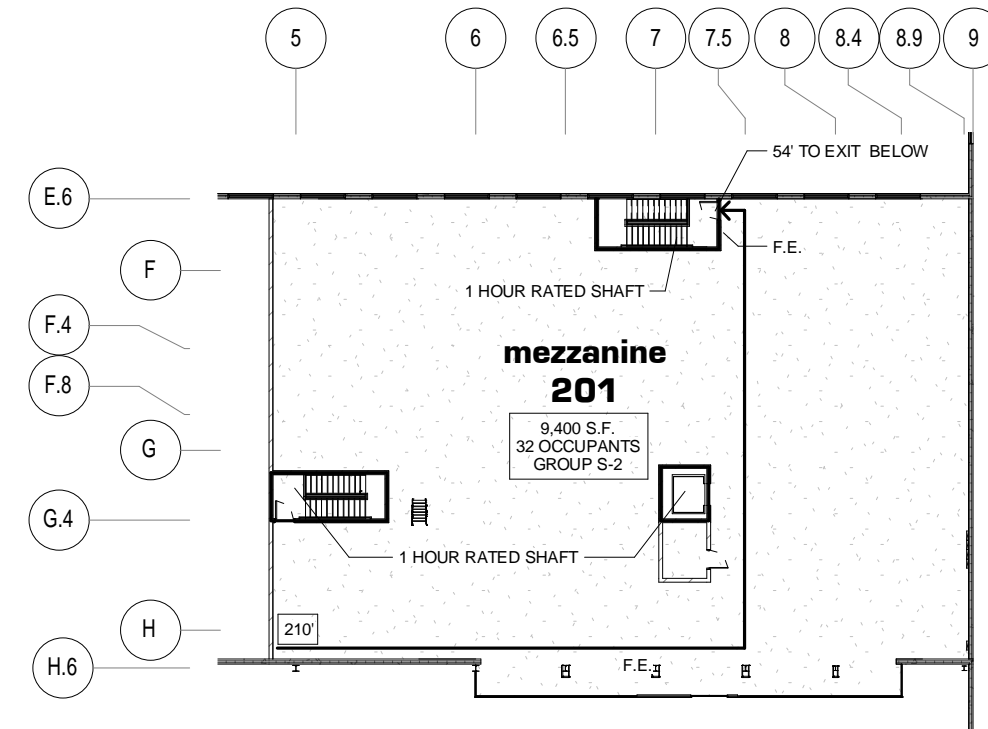

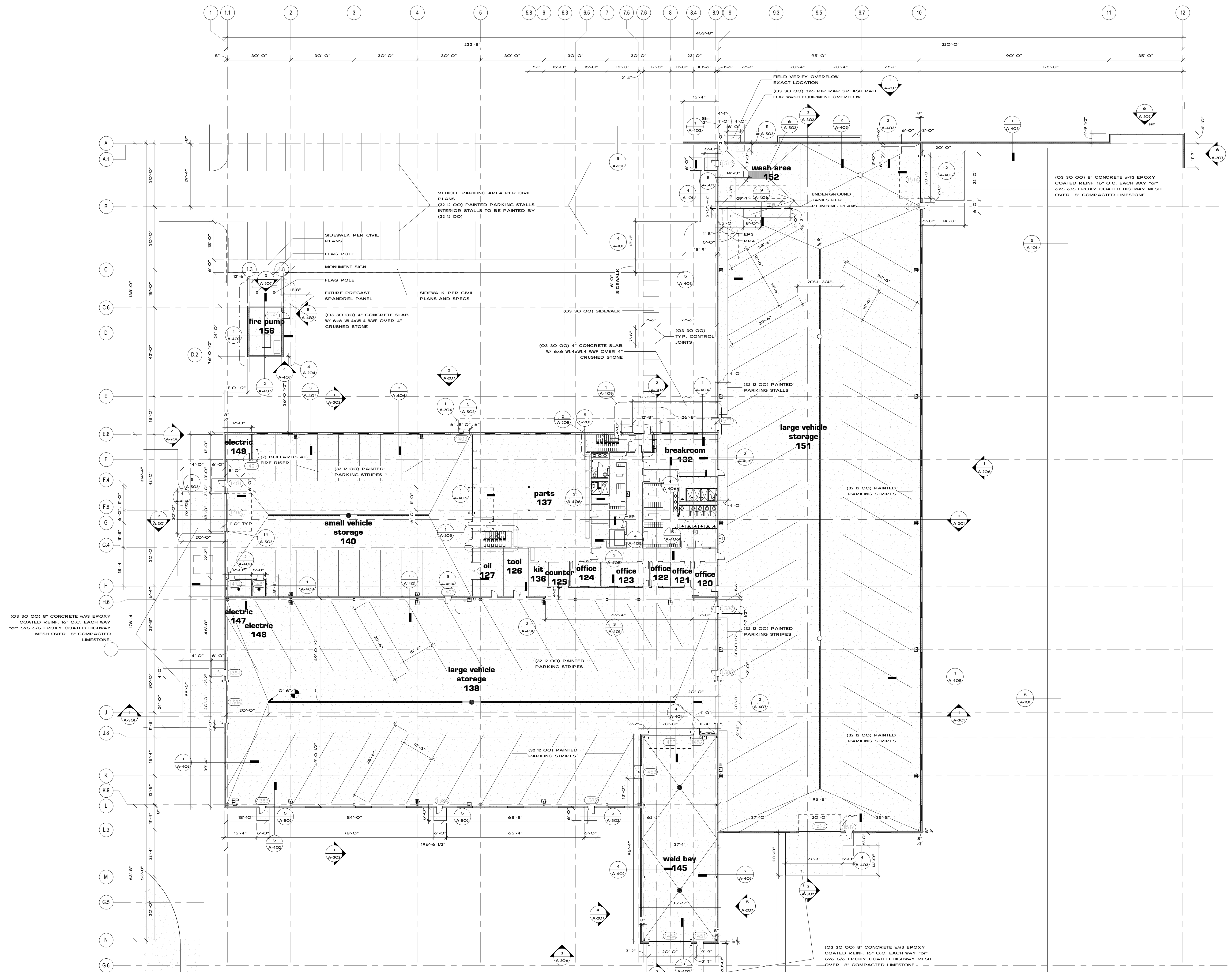

1 Floor Plan - Phase 1
3/64" = 1'-0"

First Floor Plan
kuenyarch.com ©2015 Kueny Architects L.L.C. - All Rights Reserved
Dane County - Dane County Highway Facility
3562 County Highway AB, Cottage Grove, WI 53558
January 12, 2015

A-201
PLAN NORTH
SCALE: 3/64" = 1'-0"

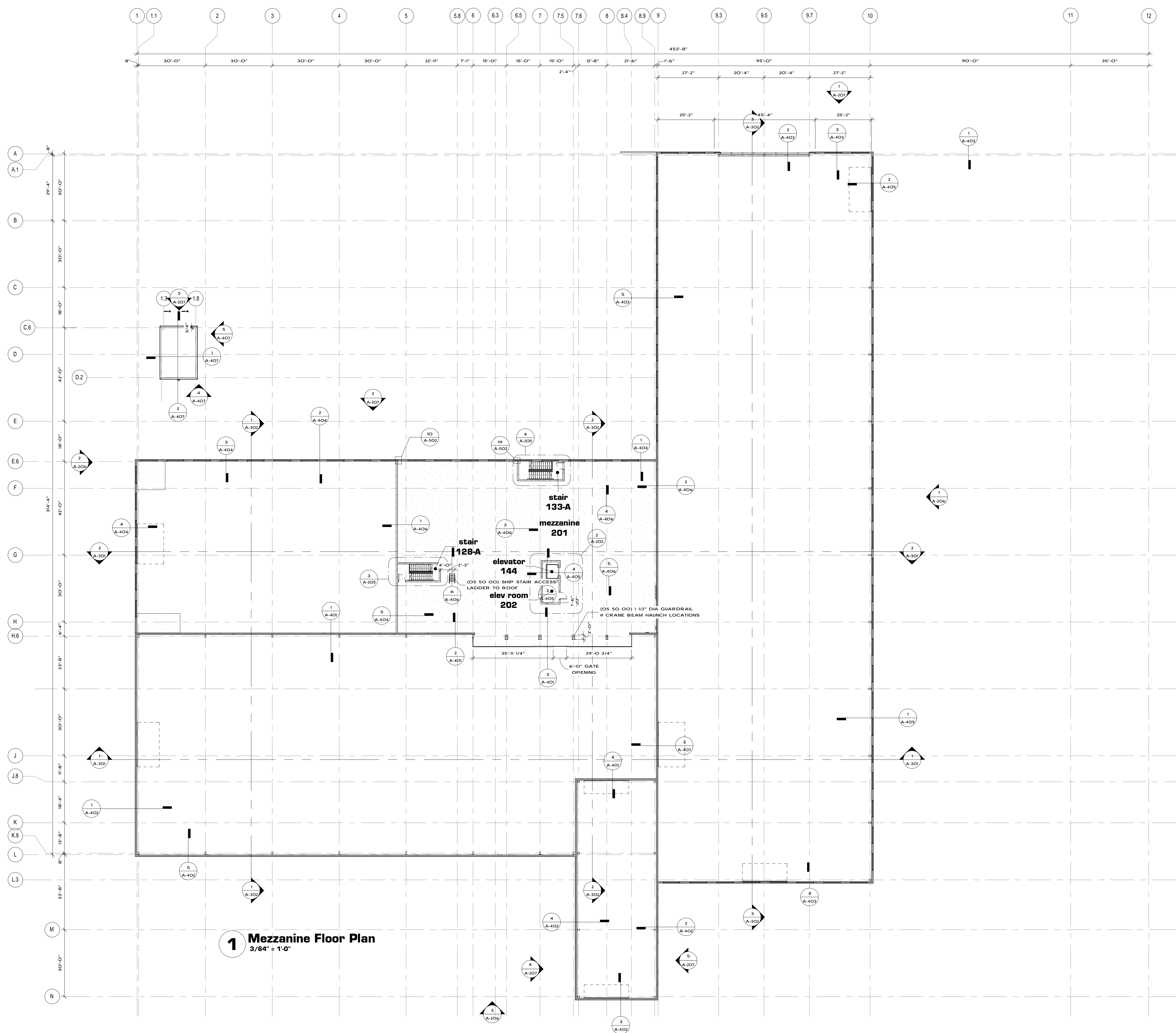

1 Mezzanine Floor Plan
3/64" = 1'-0"

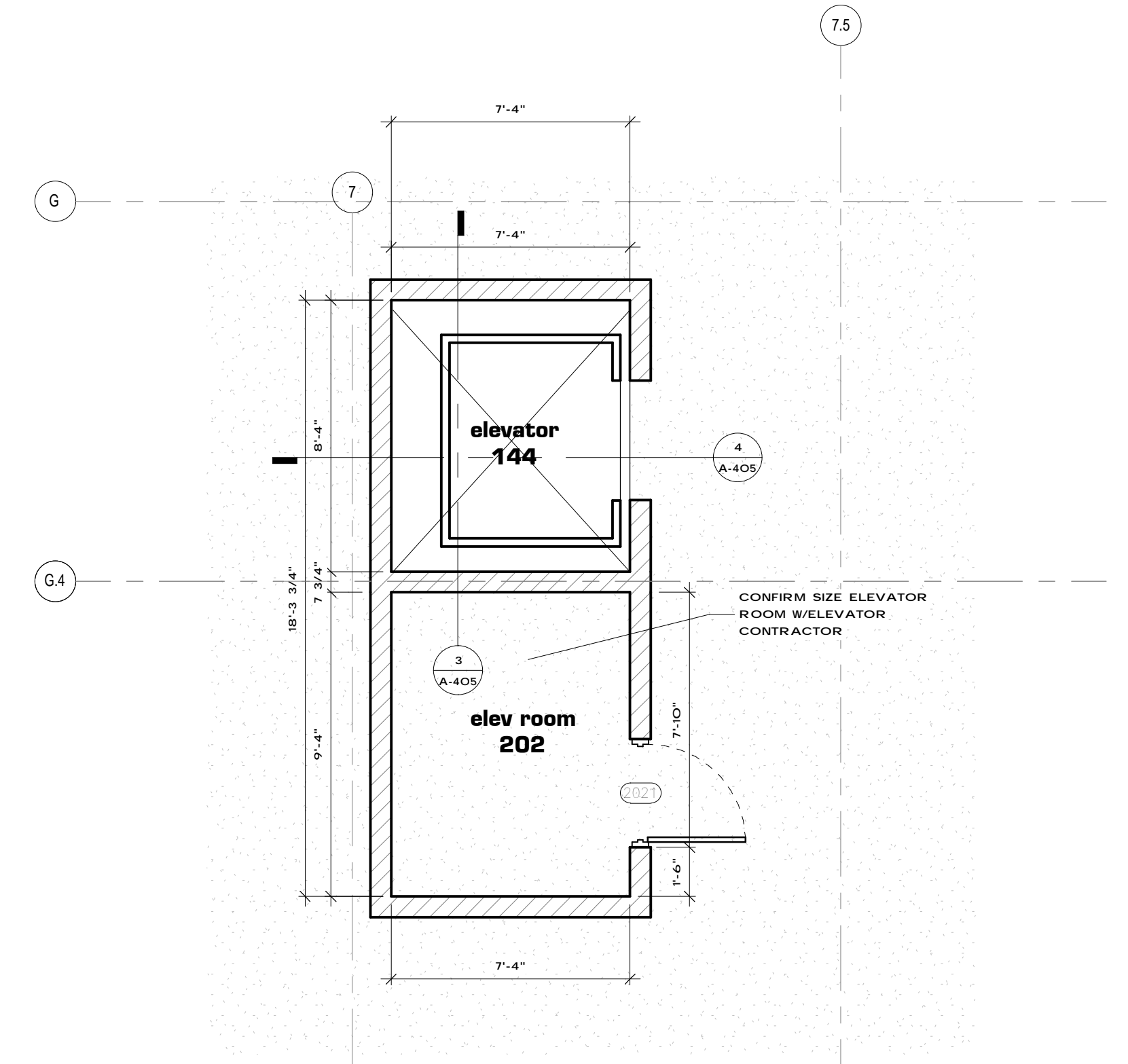

2 Enlarged Plans - Elev 144 & Elev Room 202
1/4" = 1'-0"



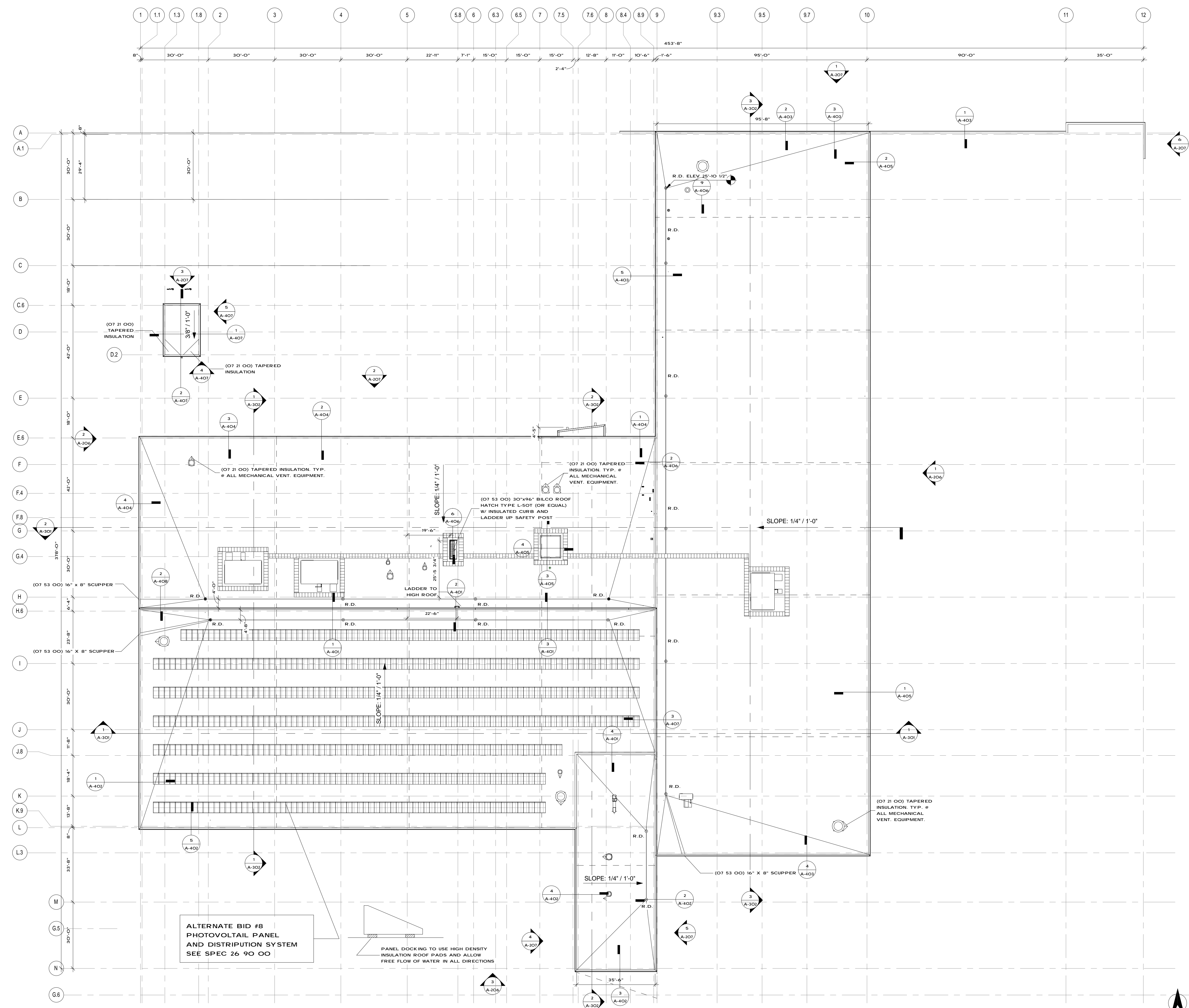

- NOTES:**
1. REFER TO FIRESTONE WEBSITE FOR THE MOST CURRENT INFORMATION.
 2. REMOVE ALL EXISTING FLASHING, LEAD, ETC. PIPE SURFACE MUST BE FREE OF ALL RUST, GREASE, INSULATION, ETC.
 3. PIPE MUST BE ANCHORED TO ENSURE STABILITY.
 4. PRE-MOLDED QUICKSEAM PIPE FLASHING MAY BE CUT TO HEIGHT, BUT NO LOWER THAN REINFORCING RING (NO WRINKLES OR FOLDS UNDER CLAMPING RING).
 5. APPLY LAP SEALANT BETWEEN PENETRATION AND PRE-MOLDED PIPE FLASHING PRIOR TO INSTALLATION OF CLAMPING RING.
 6. PRE-MOLDED PIPE FLASHING FITS 1"(25 mm) - 6" (152 mm) PENETRATIONS SIZES.
 7. DO NOT USE WHEN SERVICE LINE TEMP. EXCEEDS 180°F.

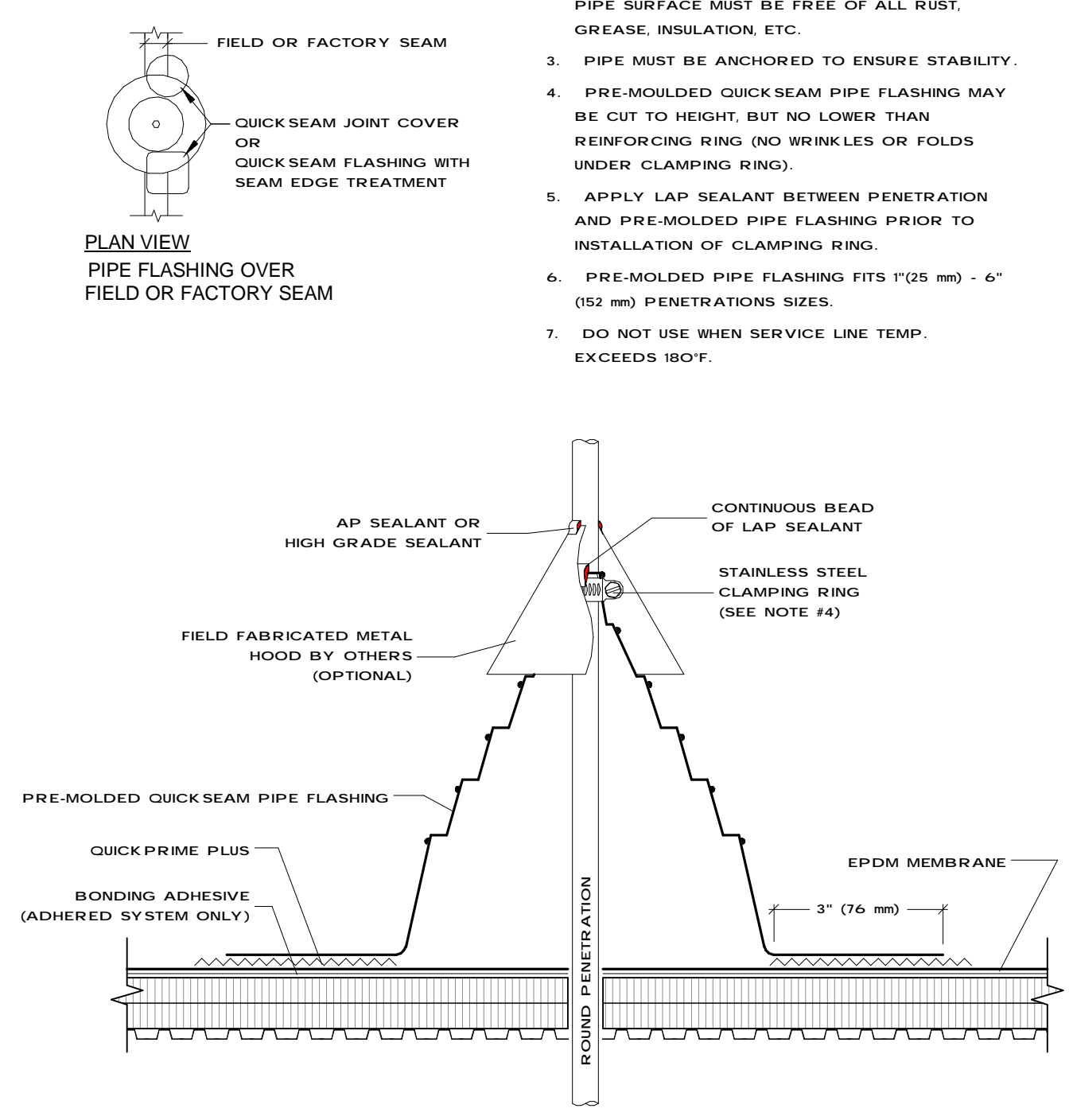

2 Roof Flashing - Pipe Penetration
NOT TO SCALE

1 Roof Plan
3/64" = 1'-0"

ALTERNATE BID #8
PHOTOVOLTAIC PANEL
AND DISTRIBUTION SYSTEM
SEE SPEC 26 90 00

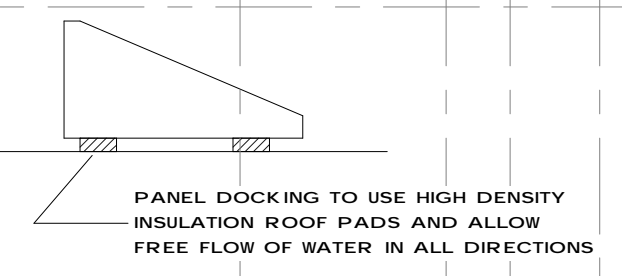

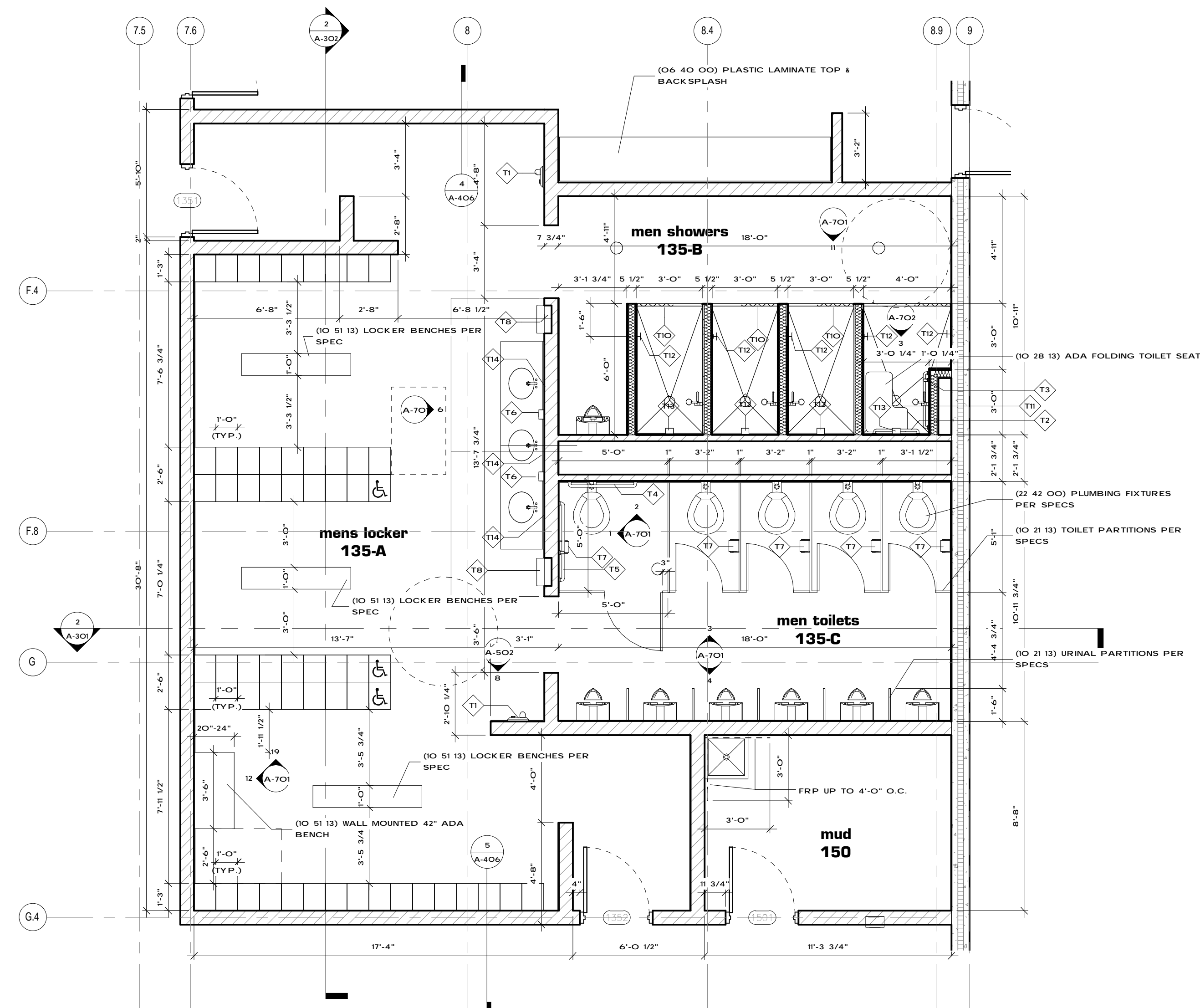

2 Men's Locker - 135
1/4" = 1'-0"

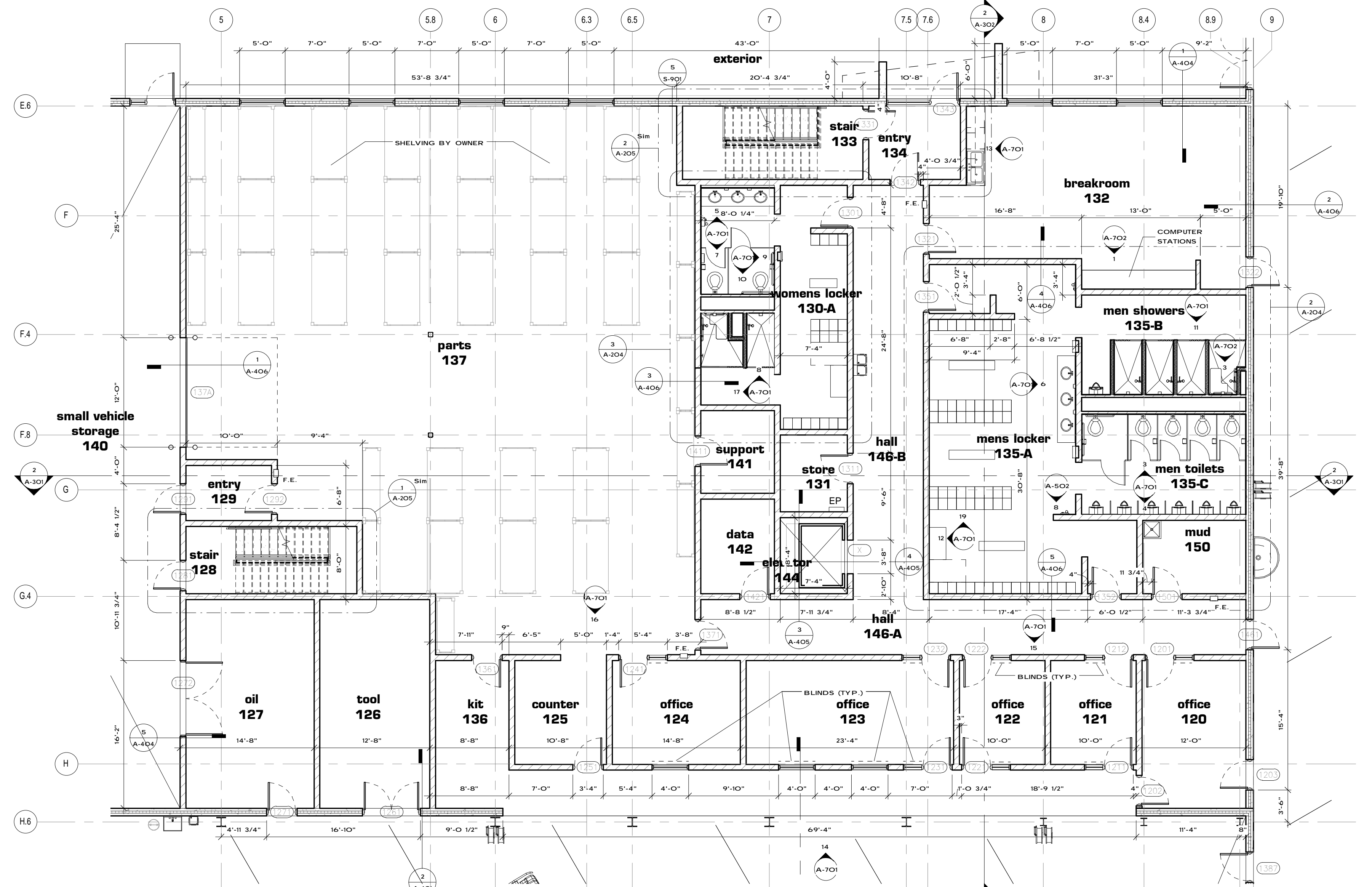

1 Offices Floor Plan
1/8" = 1'-0"

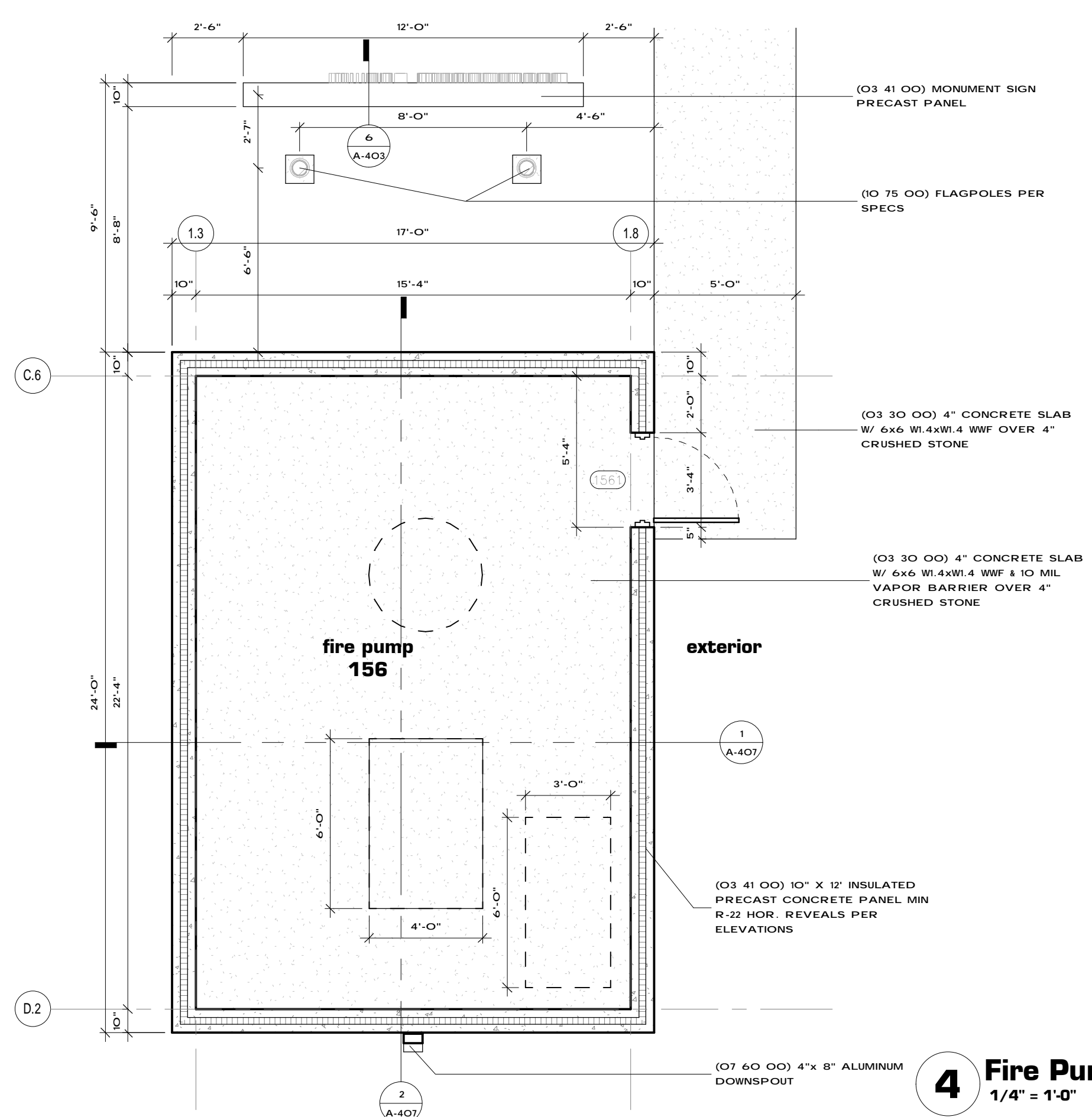

4 Fire Pump Building
1/4" = 1'-0"

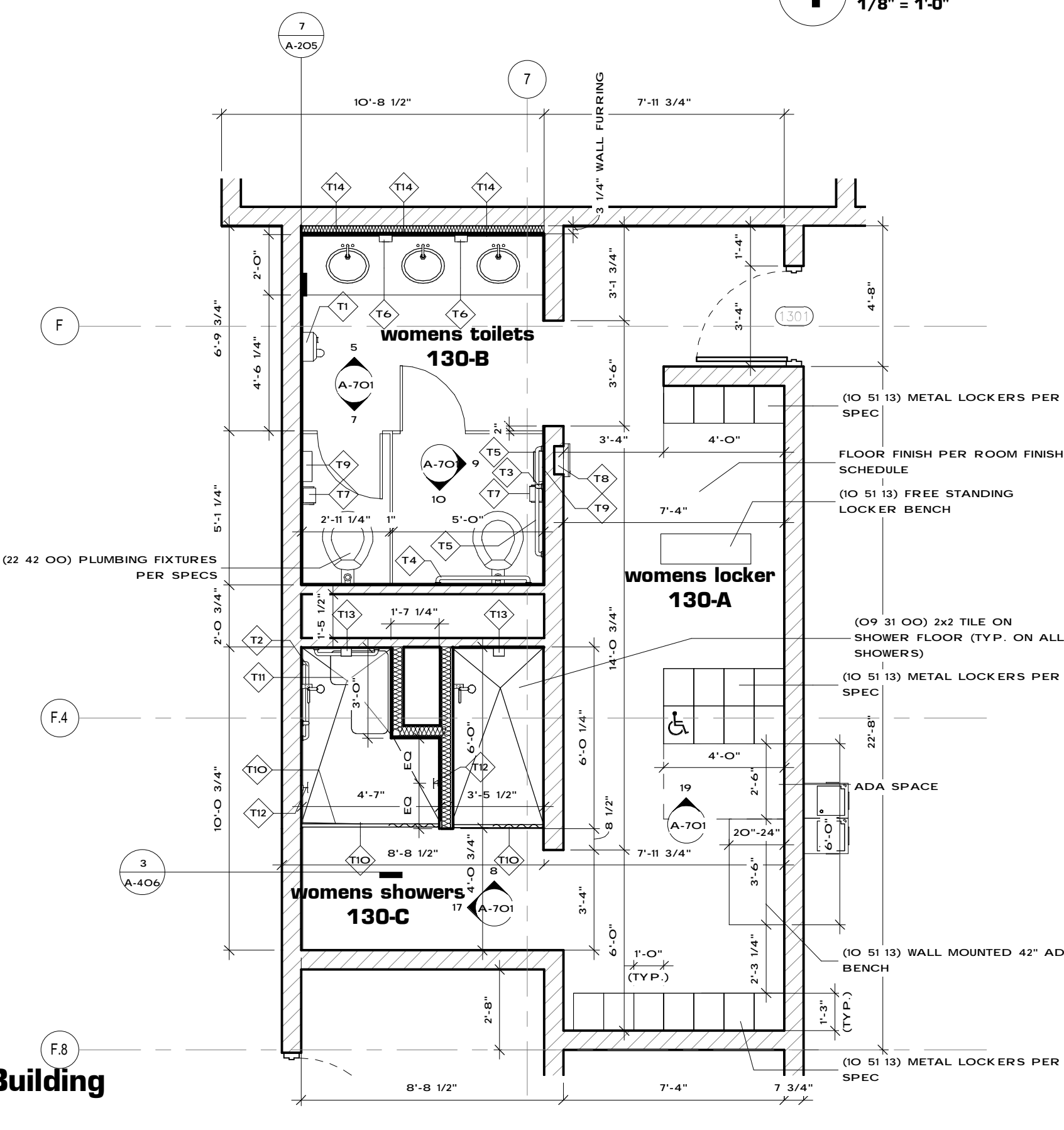

3 Women's Locker - 130
1/4" = 1'-0"

TOILET ROOM & SHOWERS ACCESSORIES				
Type Mark	Description	Comments	Option 1	Option 2
T1	Electric Hand Dryer	Per Electric Specs		
T2	Heavy Duty Shower Grab Bars	Spec Section 10 28 13		
T3	Heavy Duty Grab Bar - 18"	Spec Section 10 28 13		
T4	Heavy Duty Grab Bar - 36"	Spec Section 10 28 13		
T5	Heavy Duty Grab Bar - 42"	Spec Section 10 28 13		
T6	Wall Mounted Soap Dispenser	Spec Section 10 28 13	Bay West # 91210	Kimberly Clark # 92145
T7	Toilet Paper Dispenser	Spec Section 10 28 13	Bay West # 80200 Dubl-Serv	Kimberly Clark # 09604
T8	Paper Towel Dispenser w/ Waste Receptacle	Spec Section 10 28 13	Bobrick # B-3944	Bradley #234
T9	Sanitary Napkin Disposal	Spec Section 10 28 13	Bobrick # B-353	Bradley #4737
T10	Shower Rod w/Curtain	Spec Section 10 28 13	Bobrick # B-207	Bradley #9538
T11	Folding Shower Seat	Spec Section 10 28 13	Bobrick # B-5181	Bradley # 956
T12	Shower Hook	Spec Section 10 28 13	Bobrick # B-672	Bradley # 9124
T13	Soap Dish - Wall Mounted	Spec Section 10 28 13	Bobrick # B-680	Bradley # 901
T14	Tempered Glass Mirror w/ Channel Frame	Spec Section 10 28 13	Bobrick # B-2436	Bradley # 781

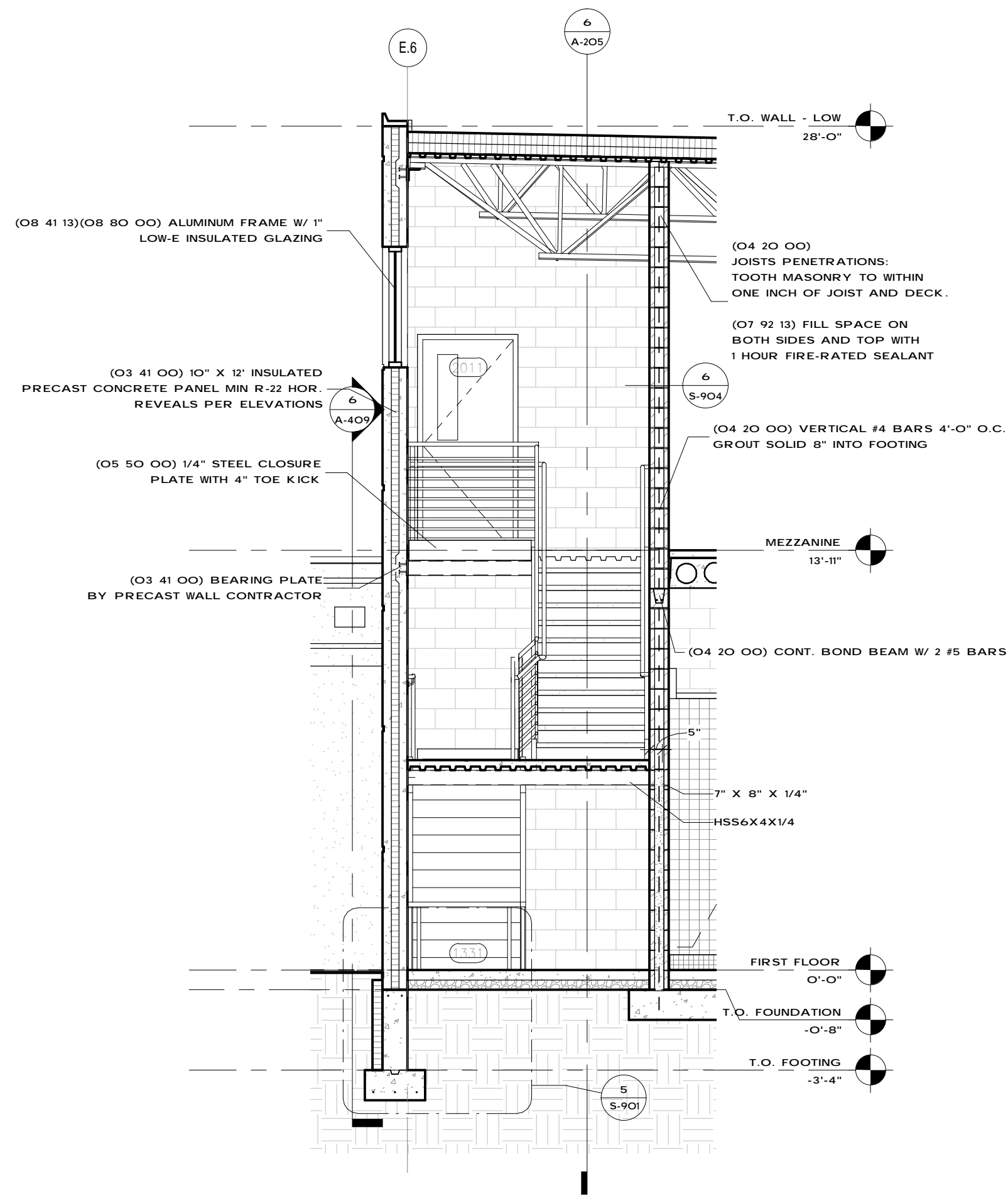

7 Stair 133/155 Section 2
1/4" = 1'-0"

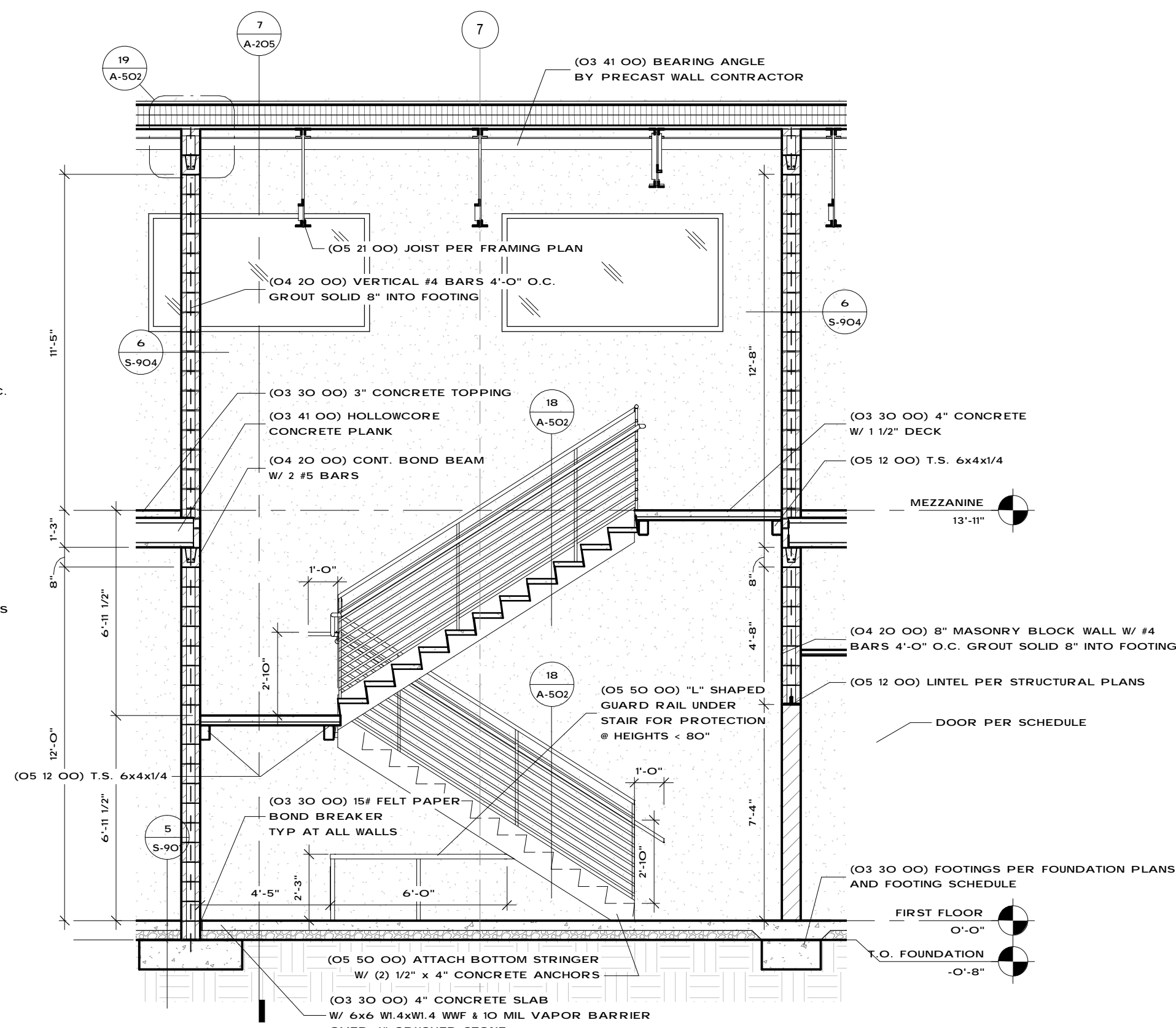

6 Stair 133/155 Section
1/4" = 1'-0"

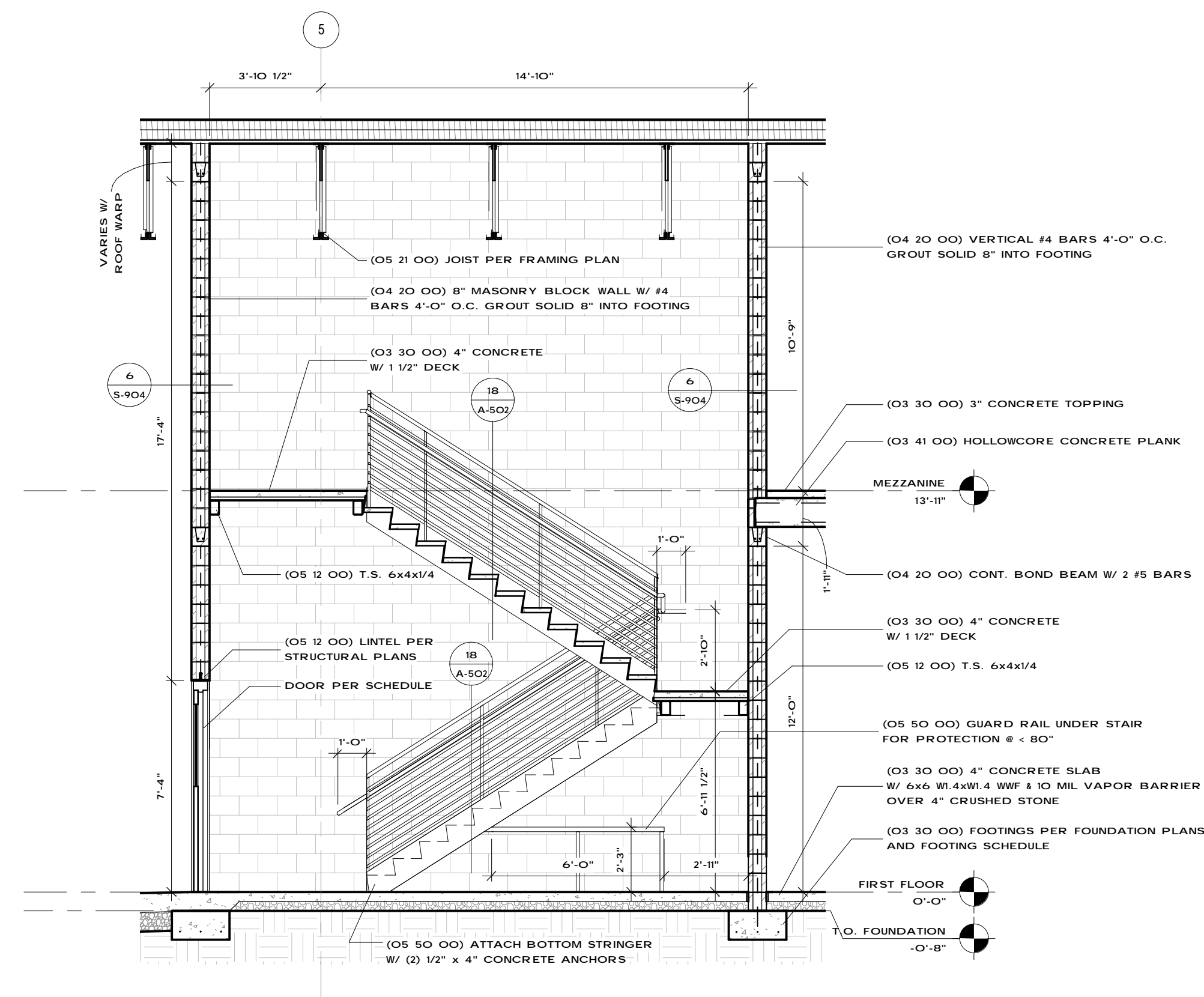

5 Stair 128/154 Section
1/4" = 1'-0"

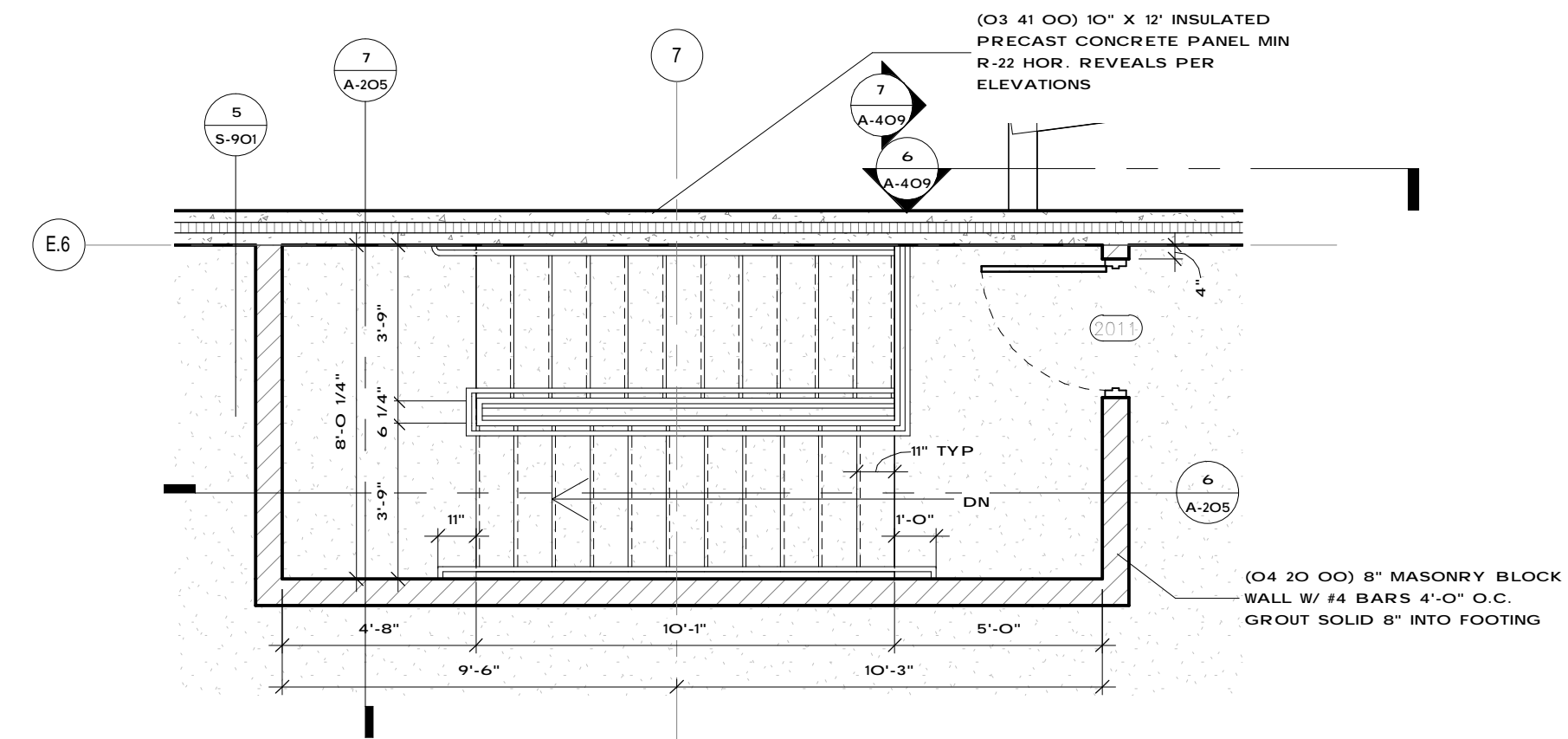

4 Stair 155 - Mezzanine
1/4" = 1'-0"

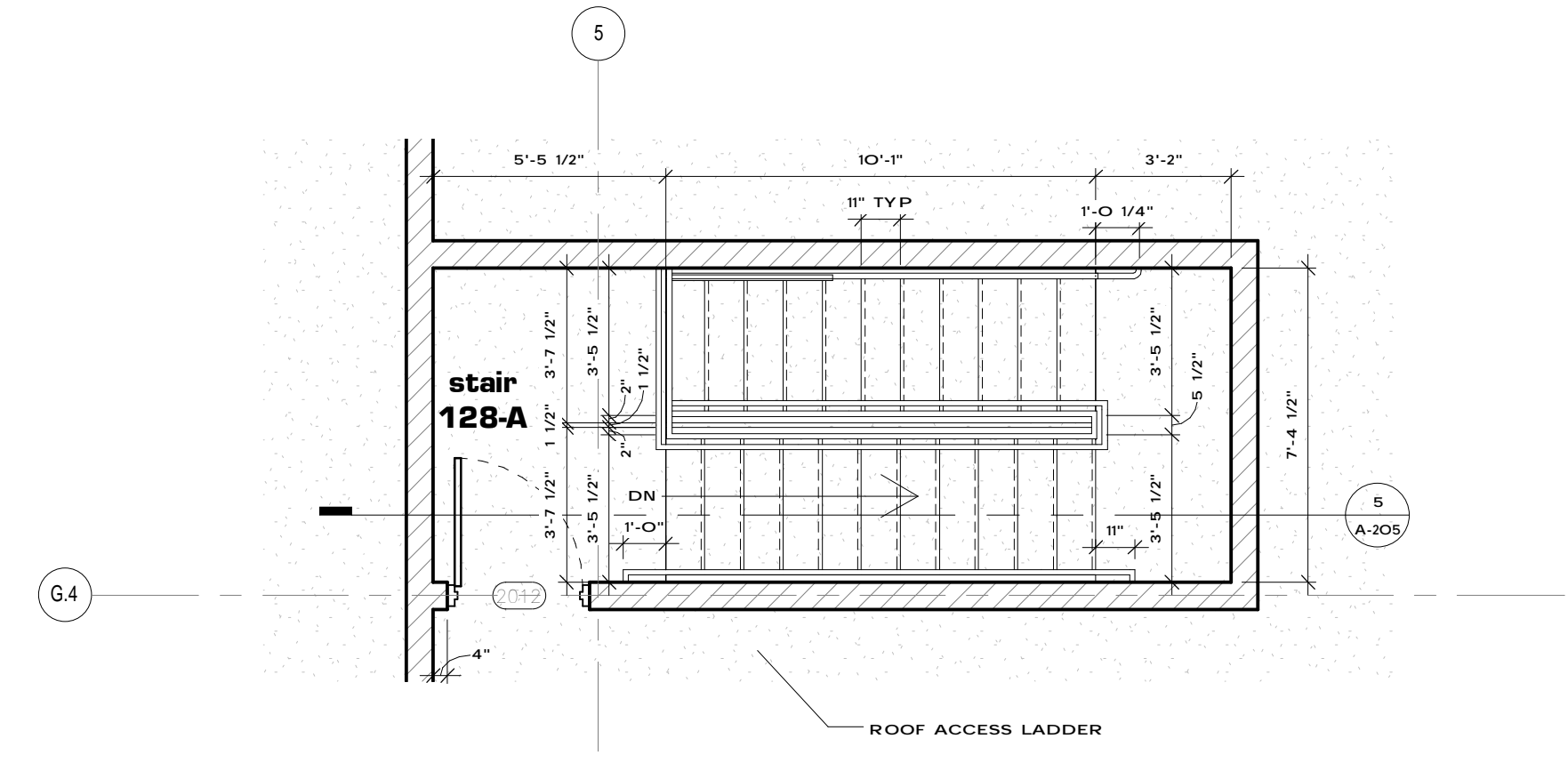

3 Stair 154 - Mezzanine
1/4" = 1'-0"

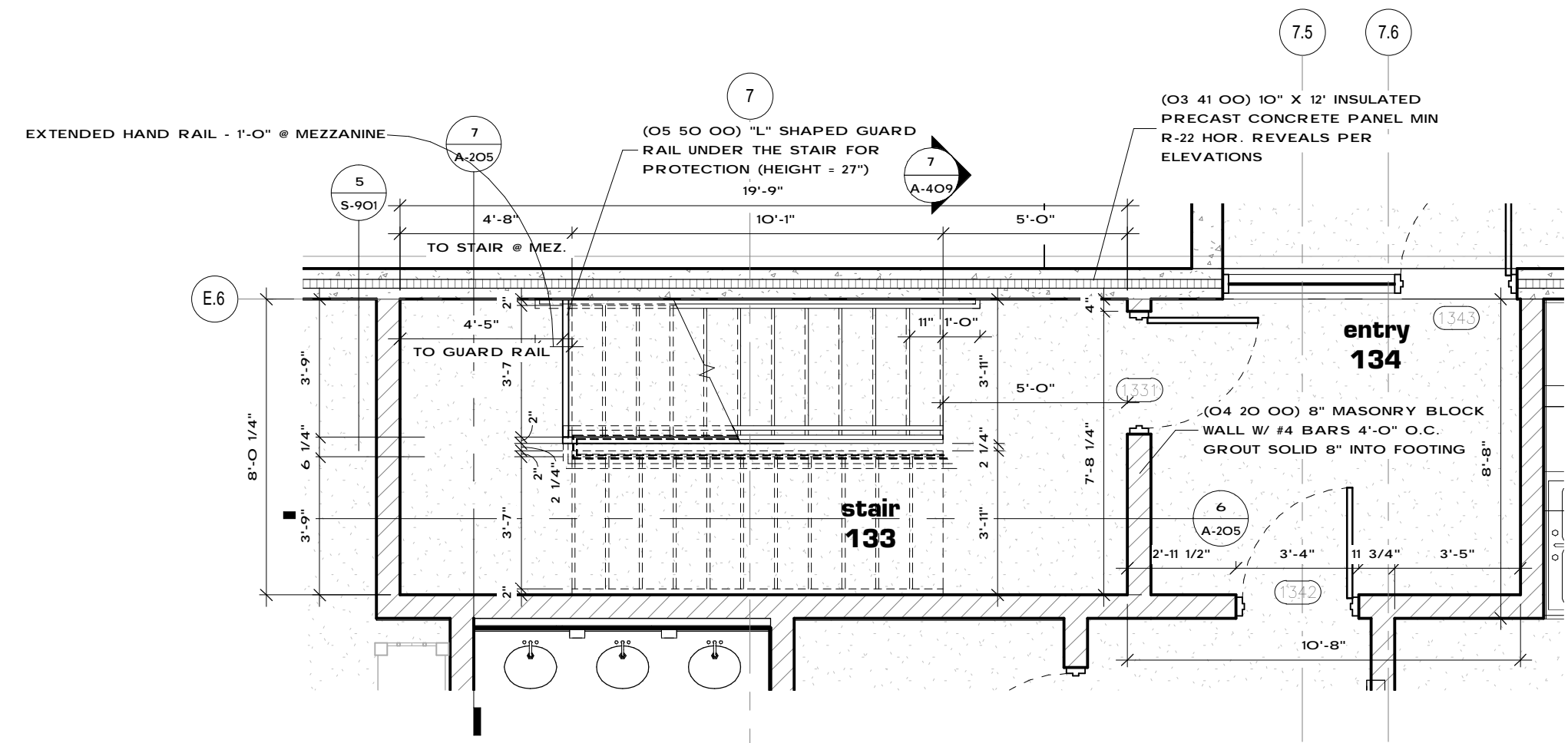

2 Stair 133 - First Floor
1/4" = 1'-0"

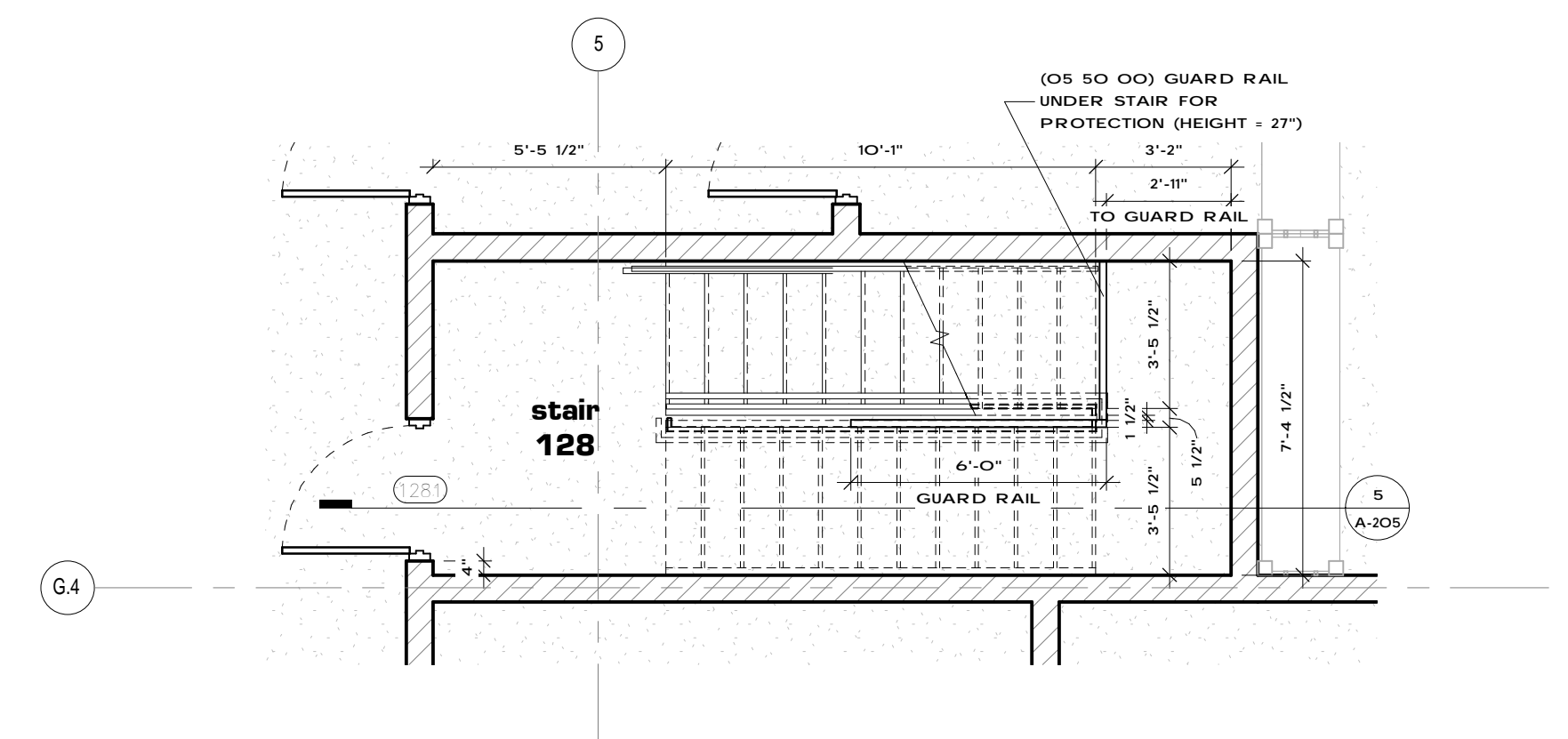

1 Stair 128 - First Floor
1/4" = 1'-0"

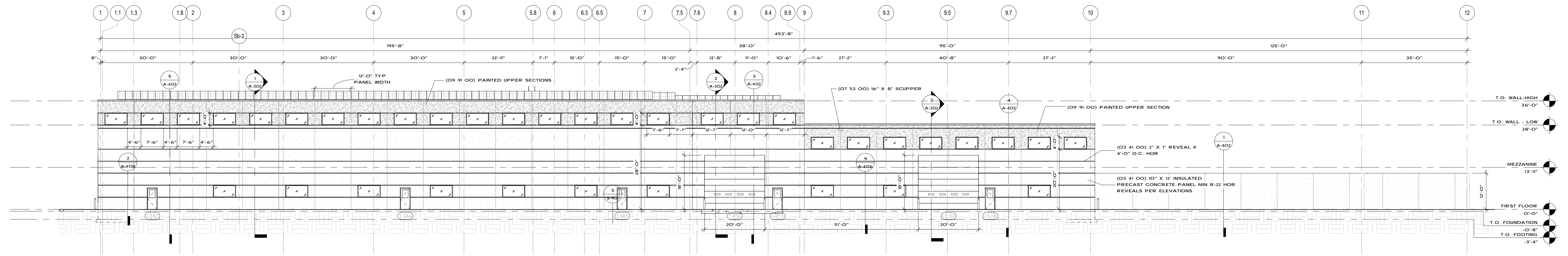

3 South Elevation
1/16" = 1'-0"

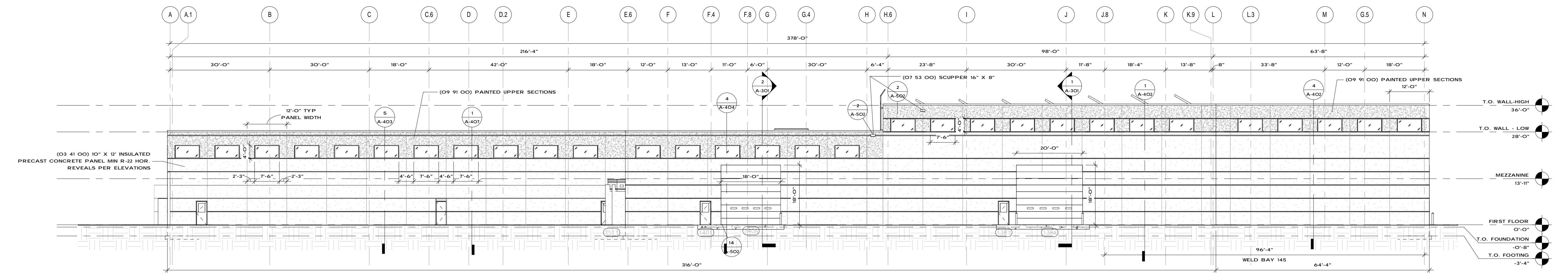

2 West Elevation
1/16" = 1'-0"

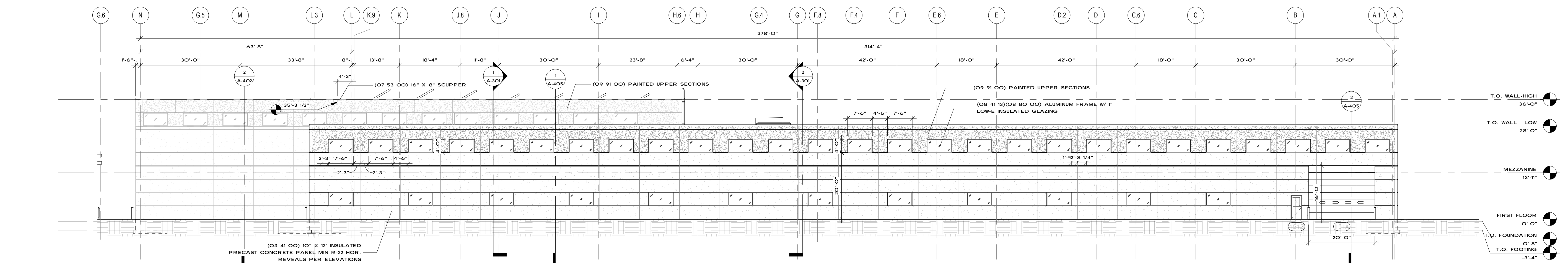

1 East Elevation
1/16" = 1'-0"

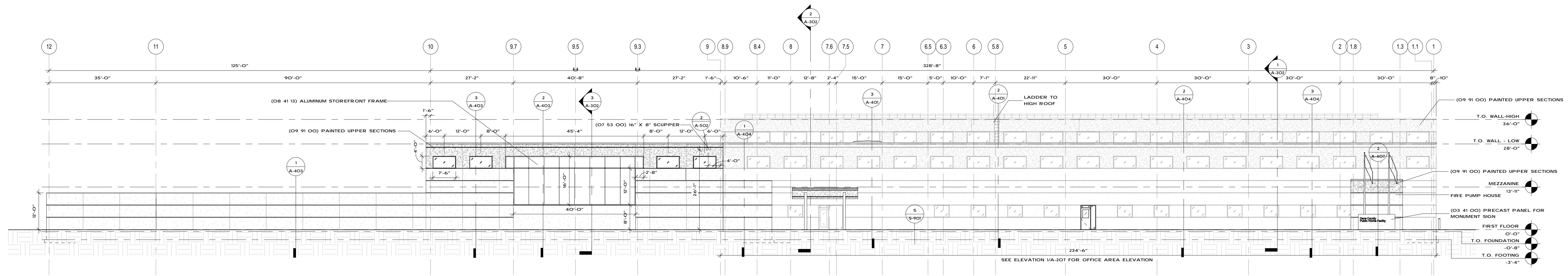

1 North Elevation
1/16" = 1'-0"

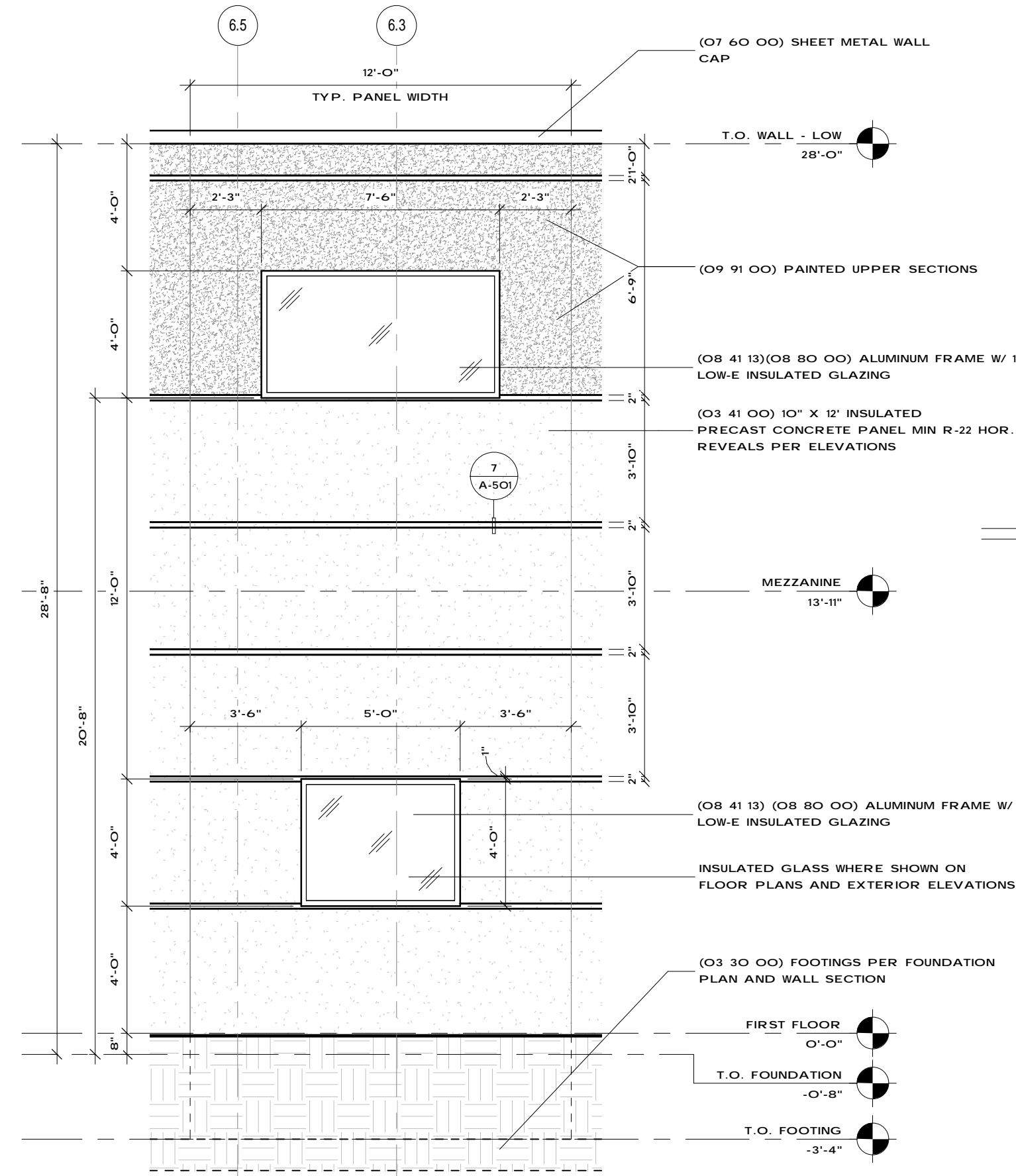

7 Typical Wall Panel Elevation
1/4" = 1'-0"

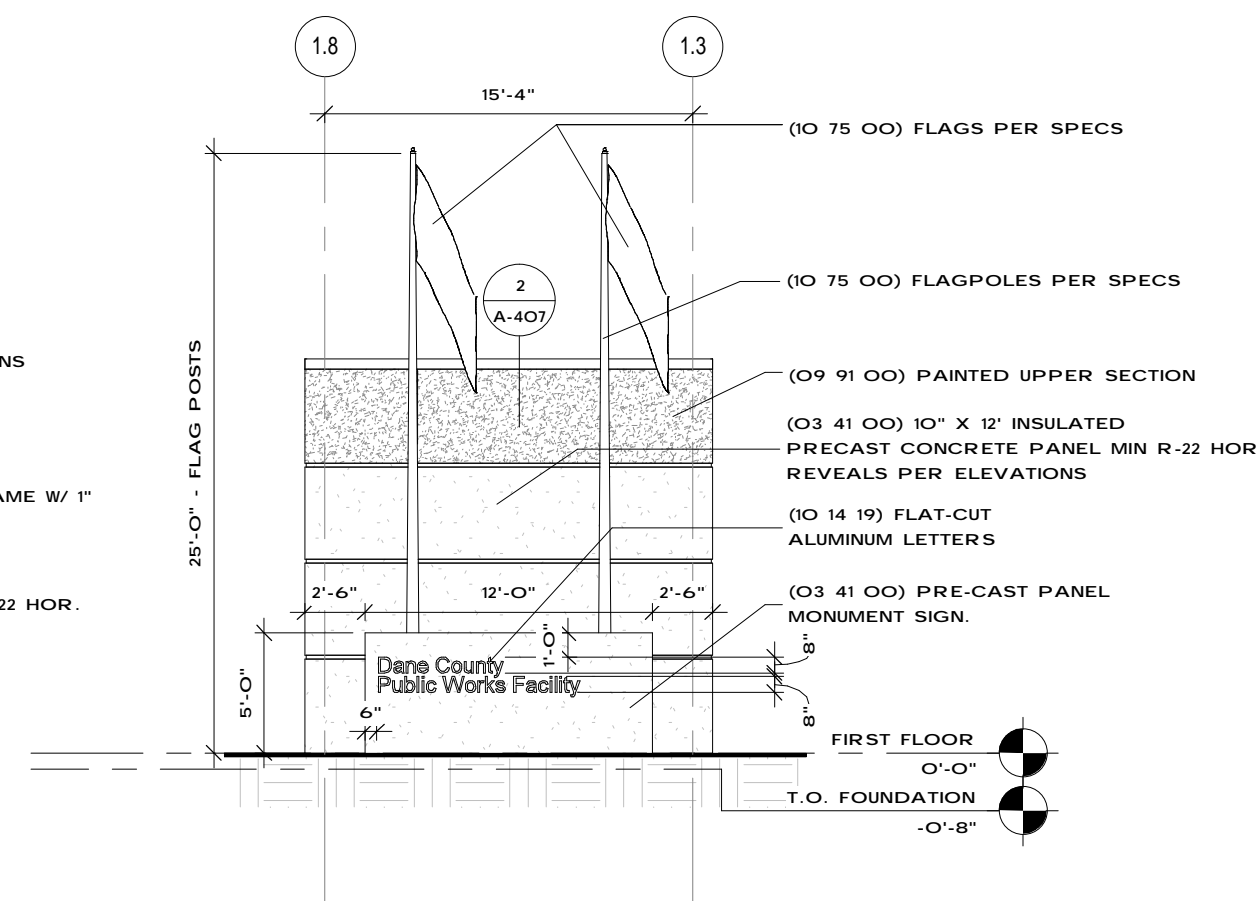

3 Monument Sign Elevation
1/8" = 1'-0"

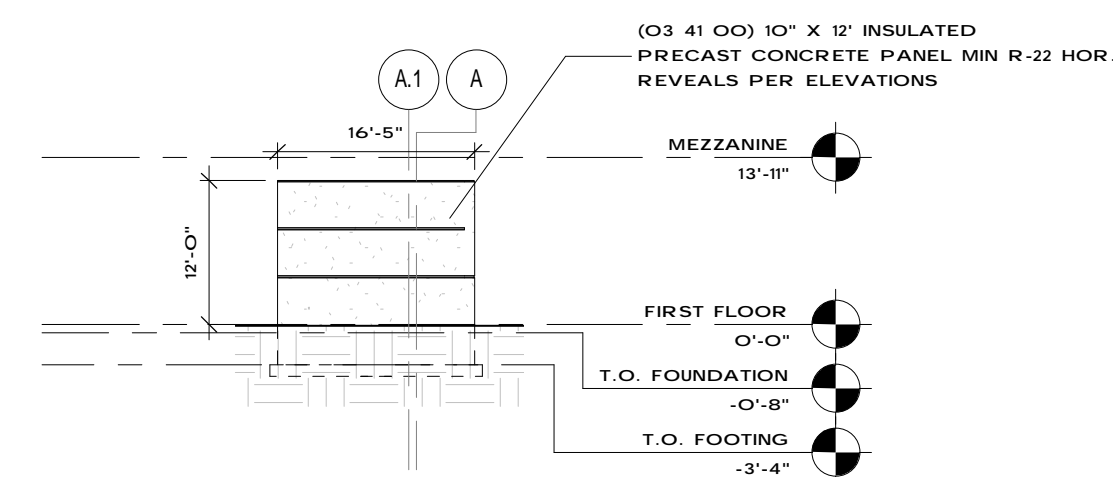

6 Typical Screen Wall Elevation
1/16" = 1'-0"

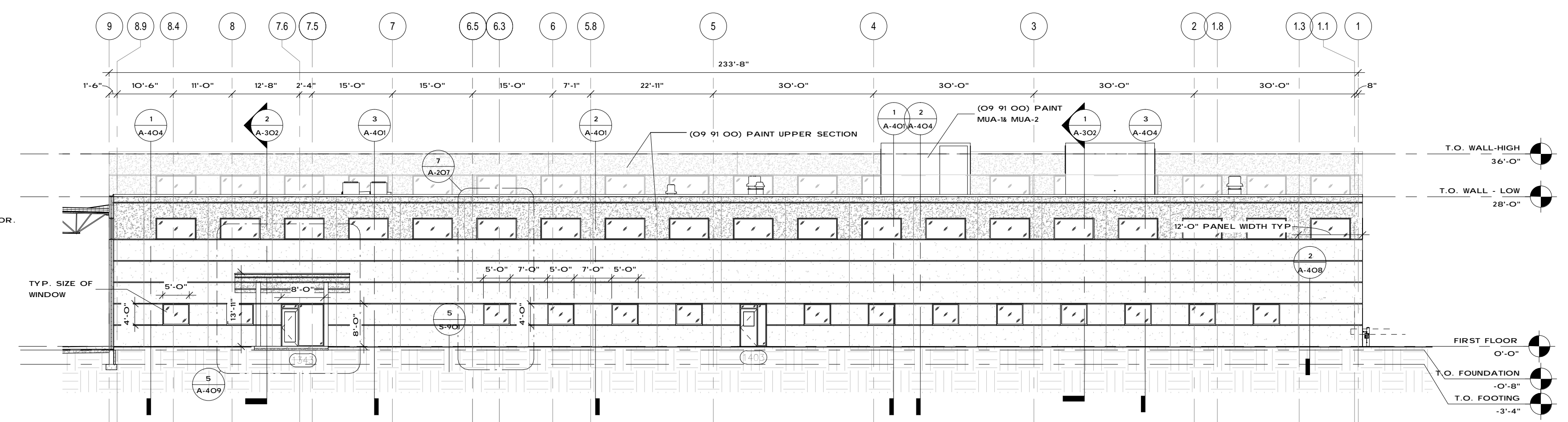

2 North Elevation - Offices
1/16" = 1'-0"

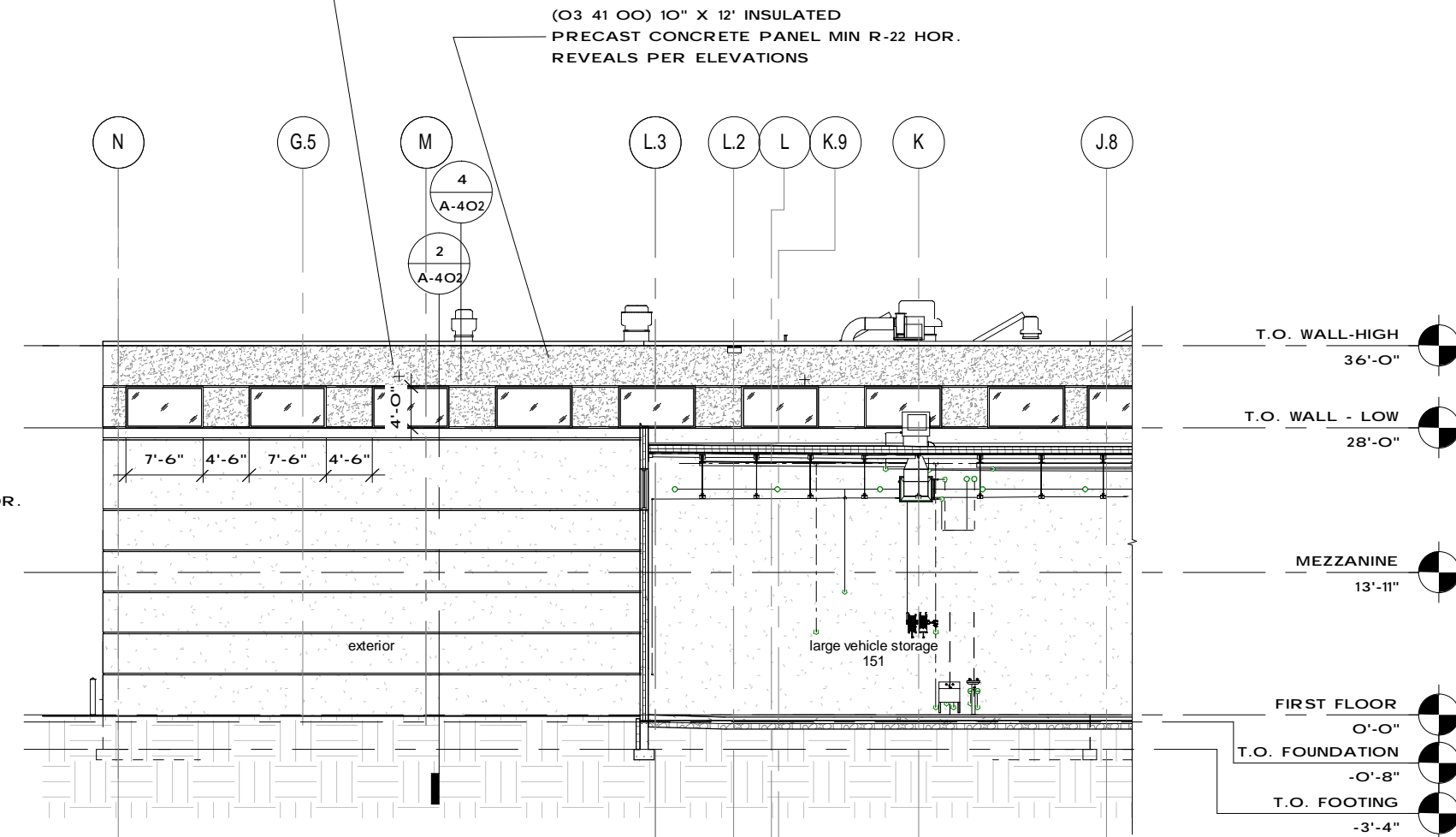

5 Weld Bay 145 - East Elevation
1/16" = 1'-0"

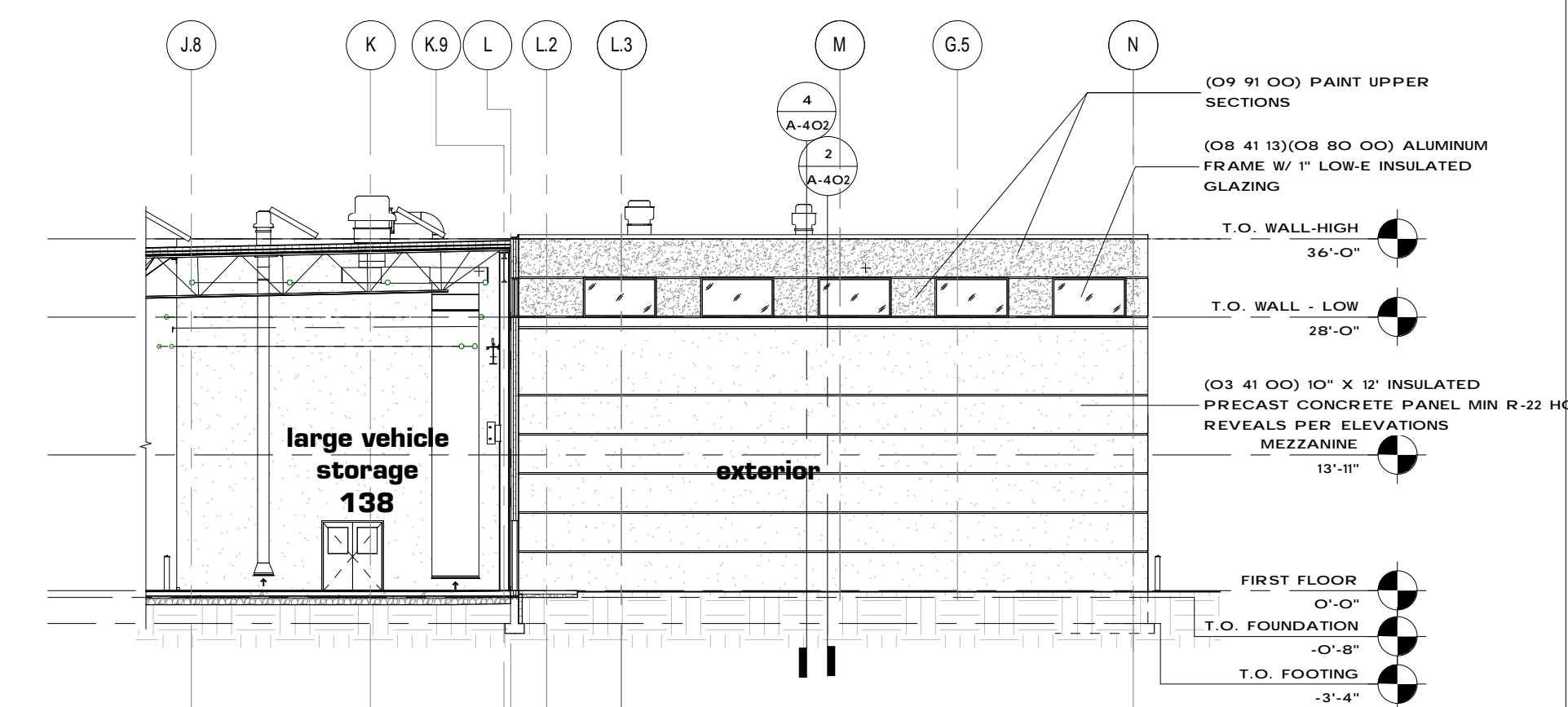

4 Weld Bay 145 - West Elevation
1/16" = 1'-0"

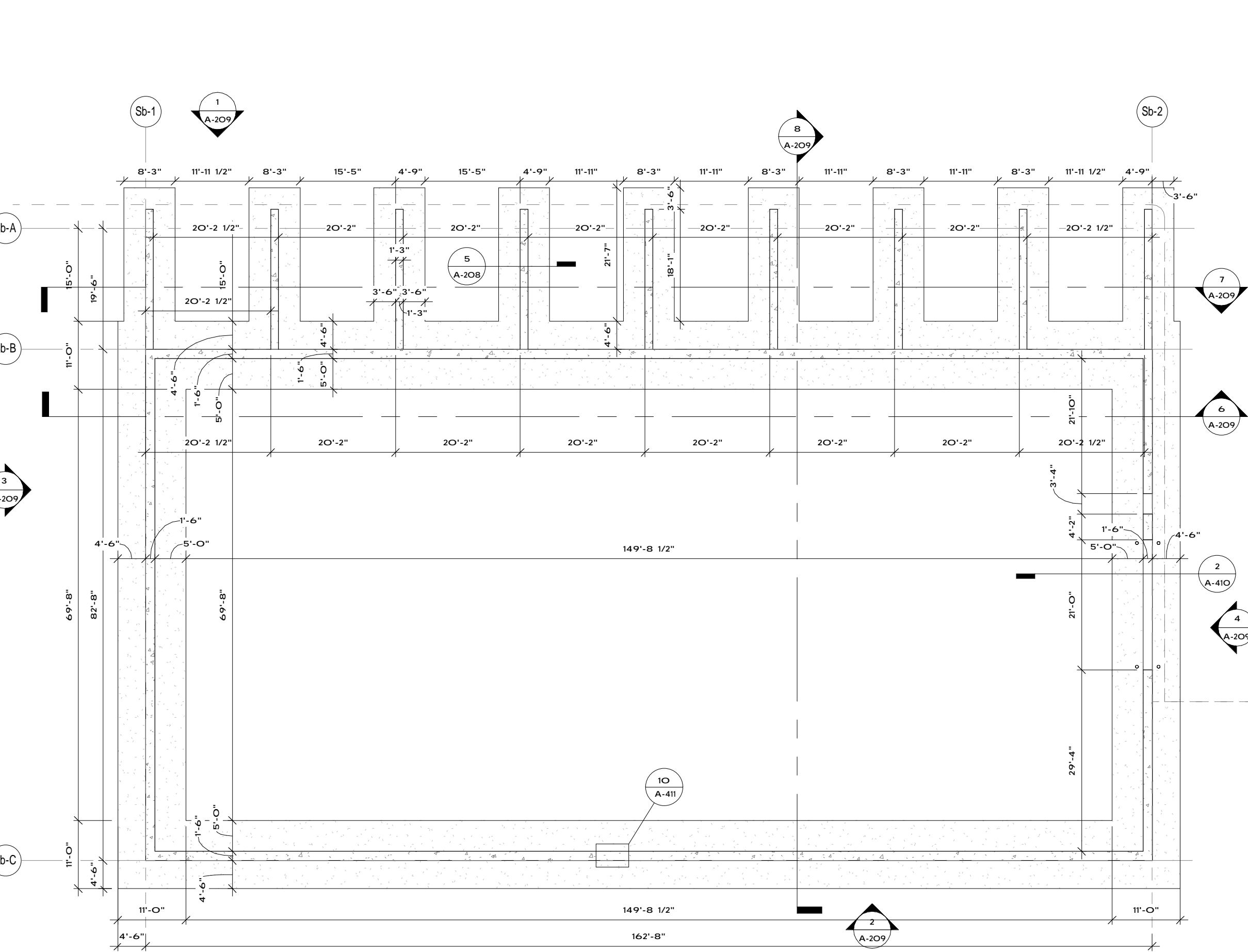
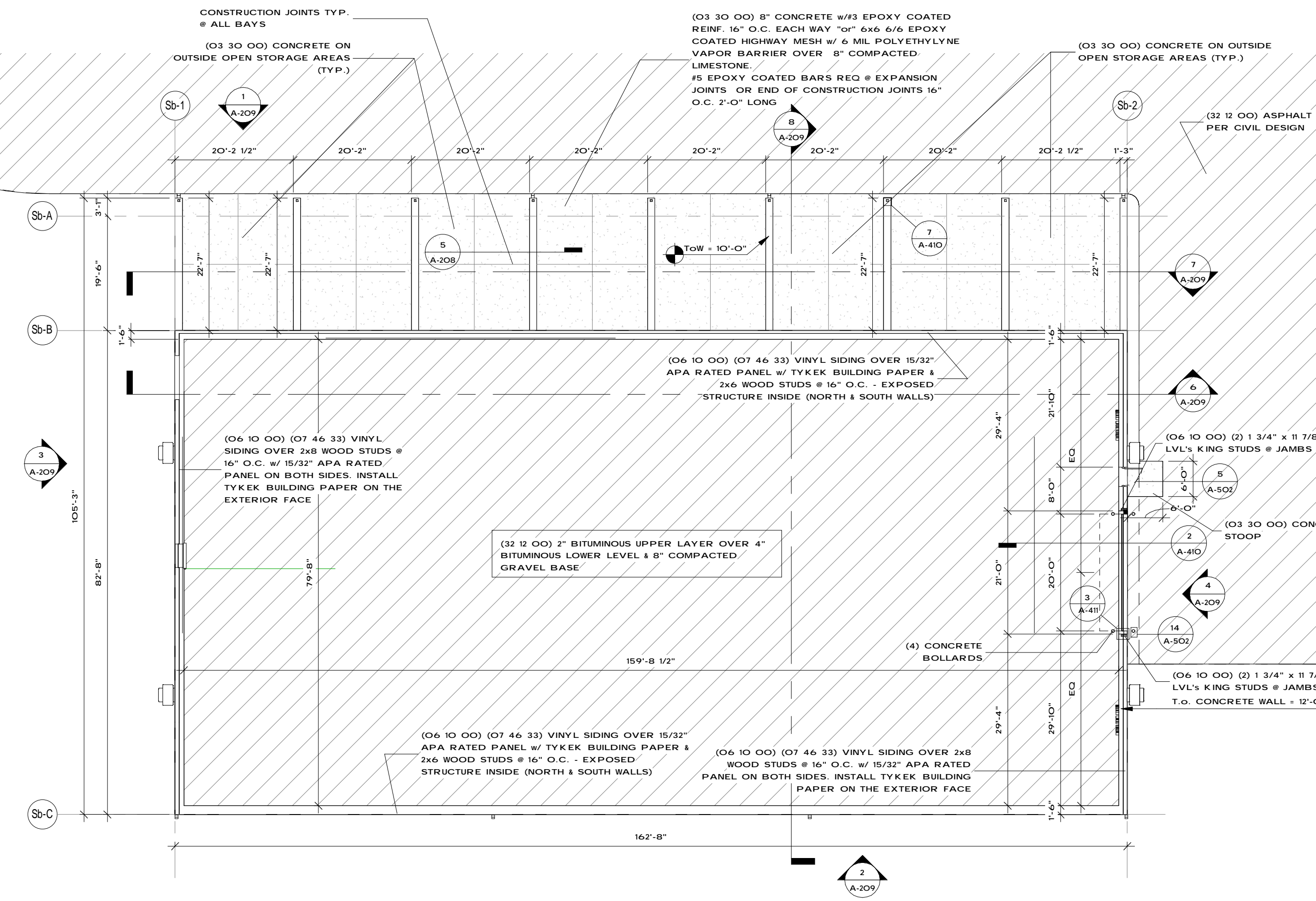
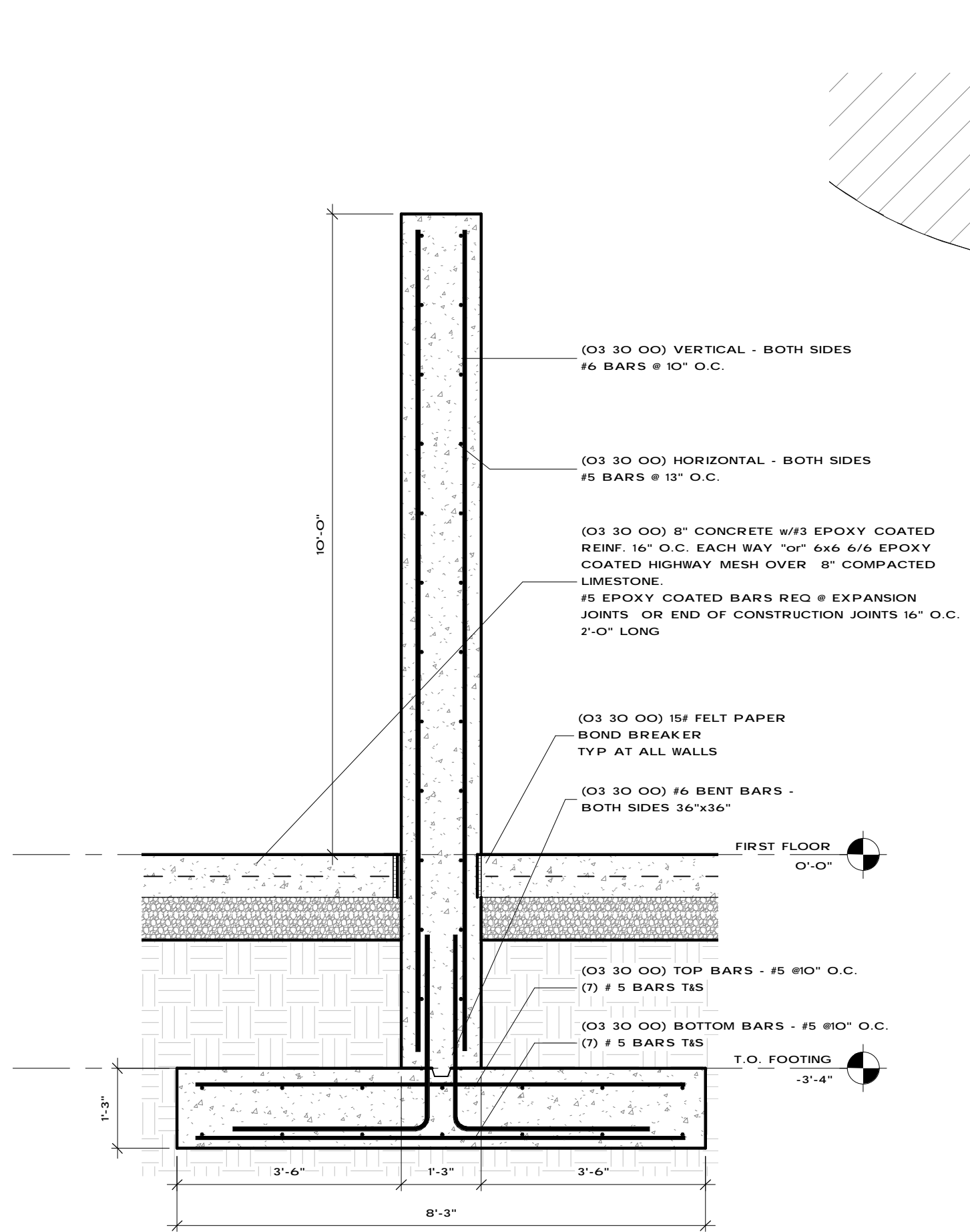

5 Salt Building - Side Bins Typ. Wall
1/2" = 1'-0"

2 Salt Building - Floor Plan - Phase 1
1/16" = 1'-0"

1 Salt Building - Foundation Plan - Phase 1
1/16" = 1'-0"

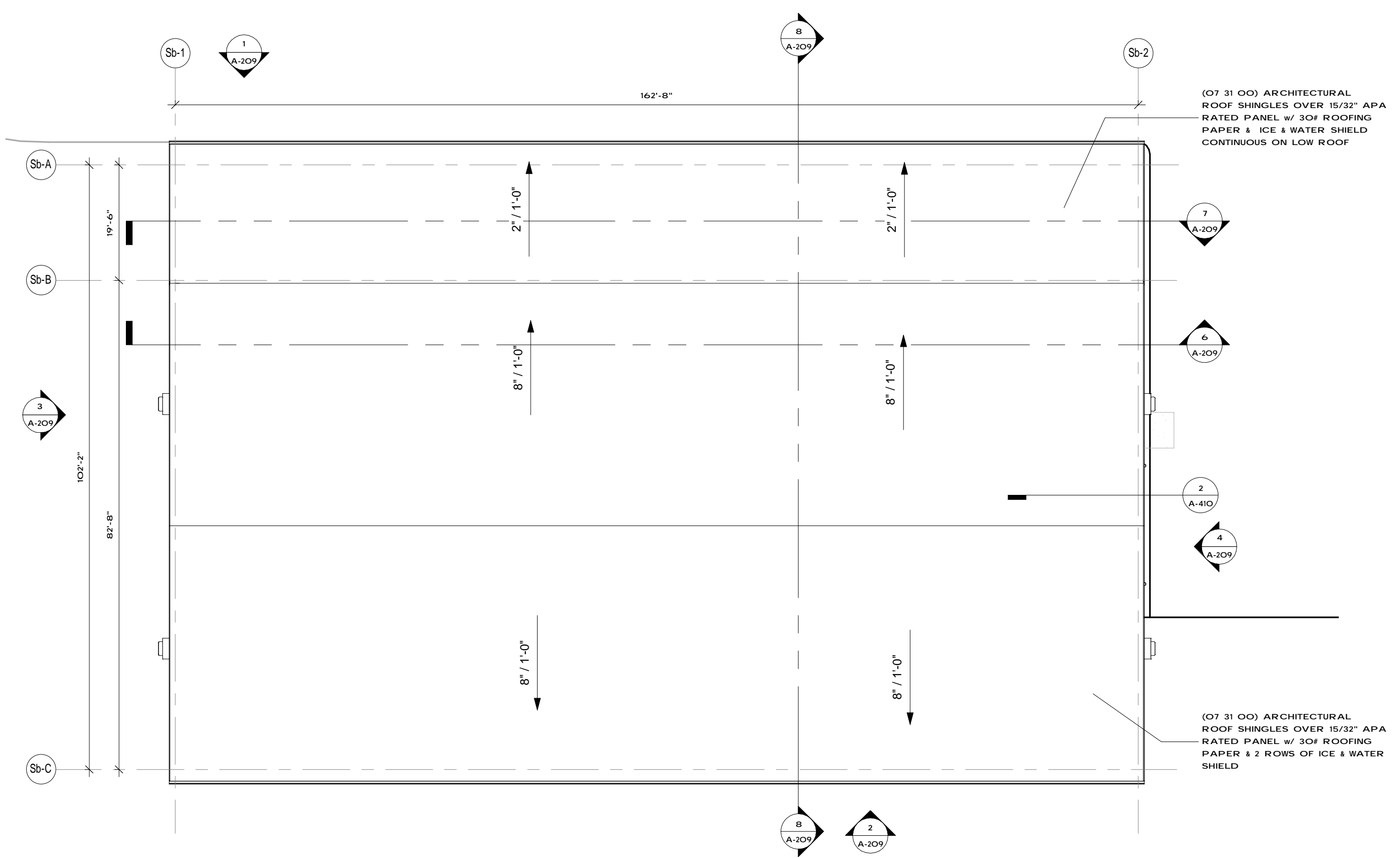

4 Salt Building - Roof Plan - Phase 1
1/16" = 1'-0"

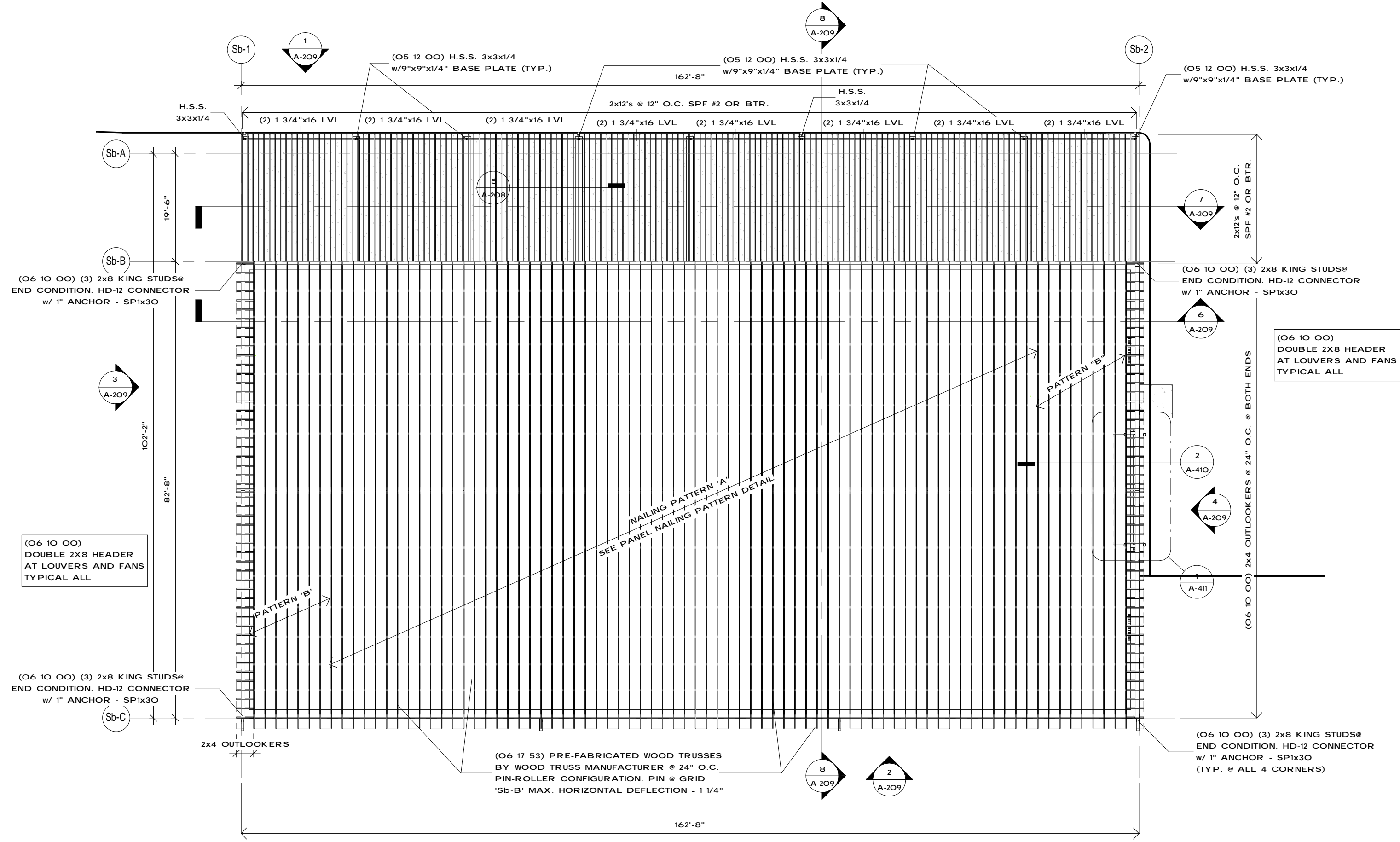

3 Salt Building - Framing - Phase 1
1/16" = 1'-0"

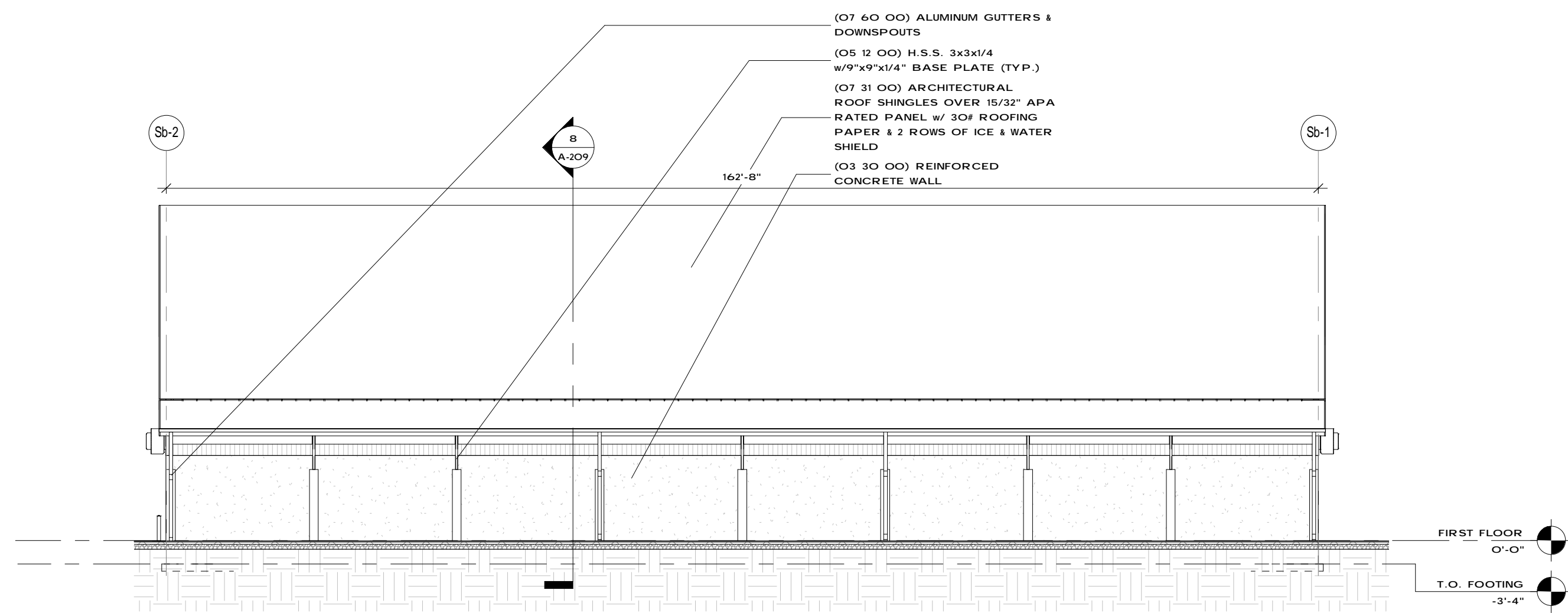

1 Salt Building - North Elevation
1/16" = 1'-0"

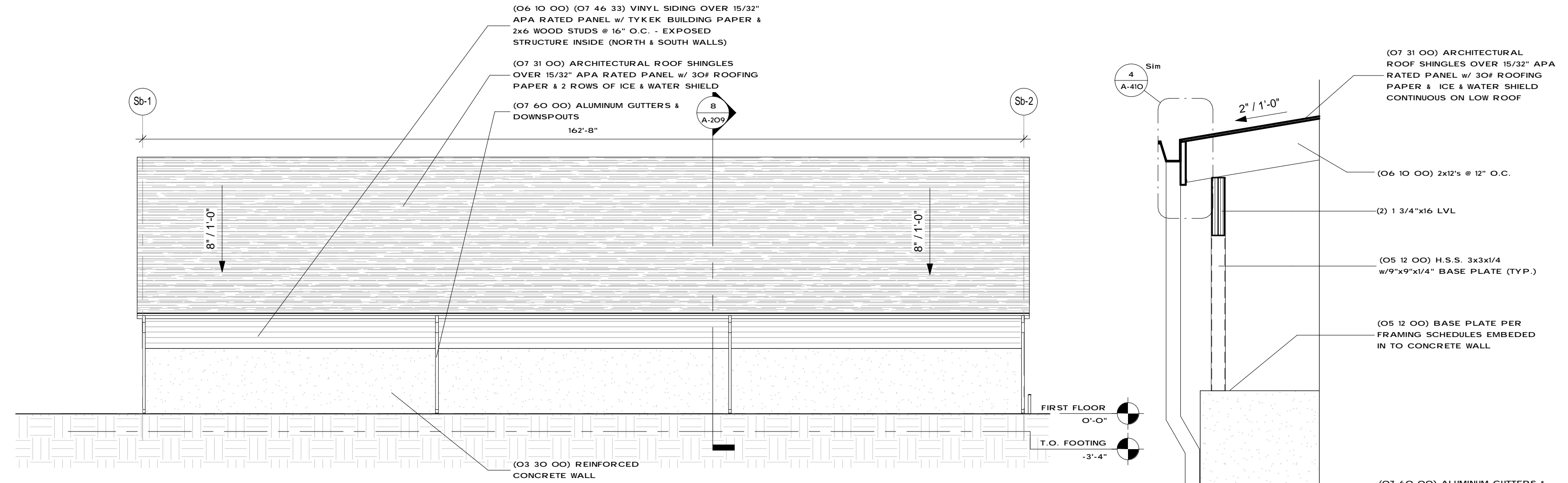

2 Salt Building - South Elevation
1/16" = 1'-0"

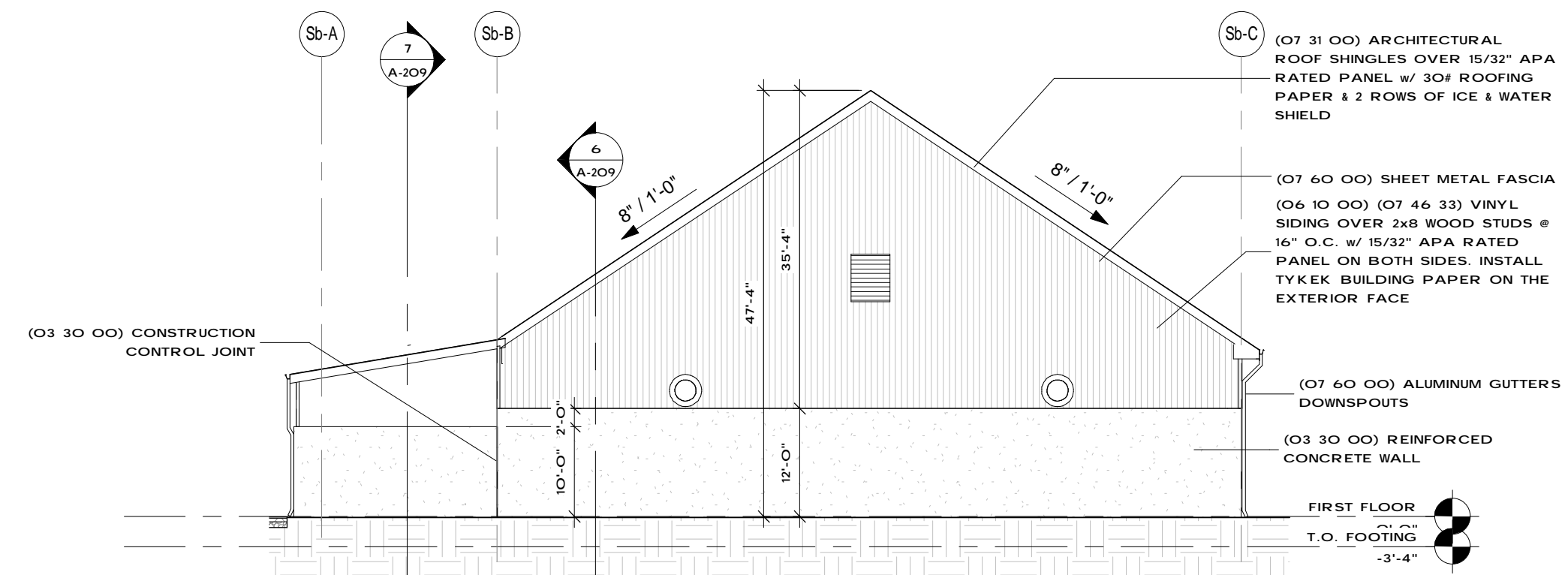

3 Salt Building - West Elevation
1/16" = 1'-0"

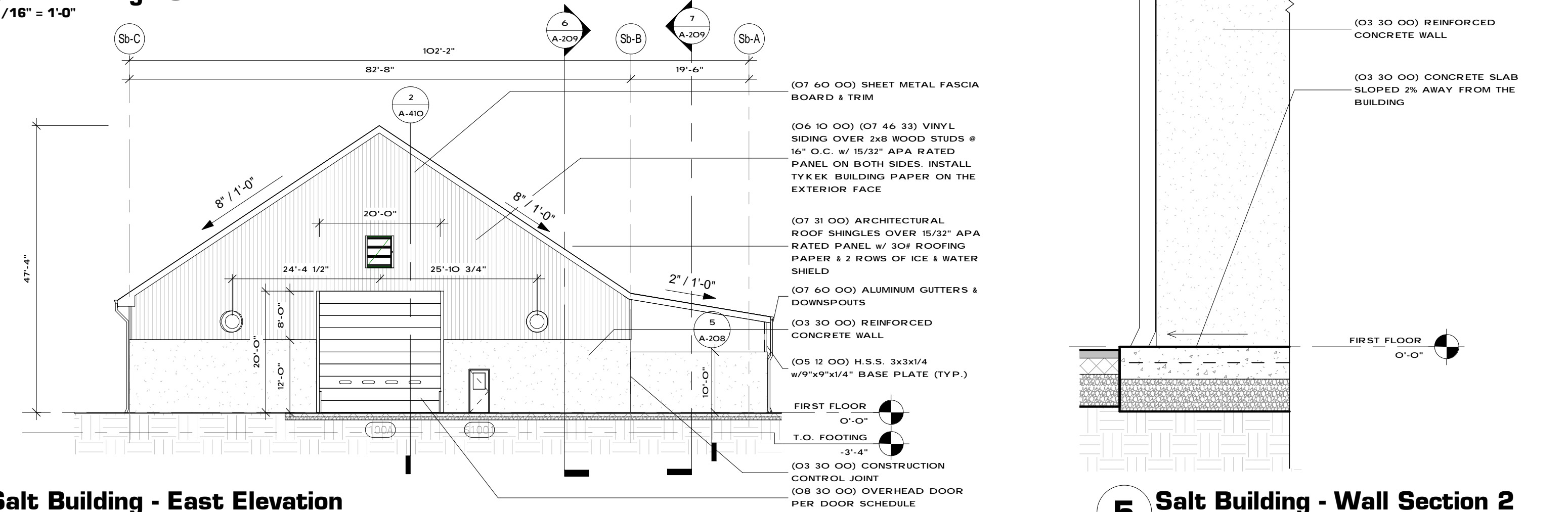

4 Salt Building - East Elevation
1/16" = 1'-0"

5 Salt Building - Wall Section 2
1/2" = 1'-0"

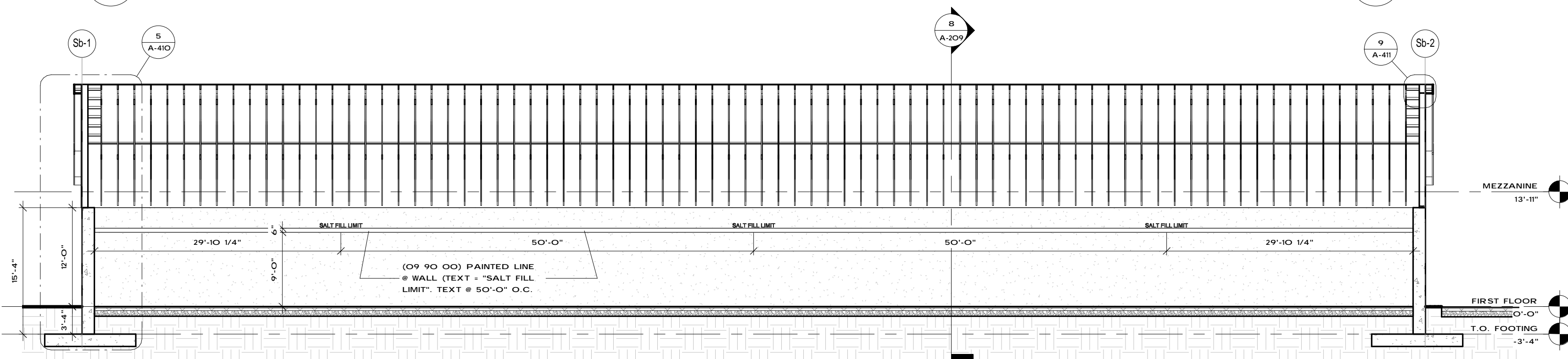

6 Salt Building - Section B-B
3/32" = 1'-0"

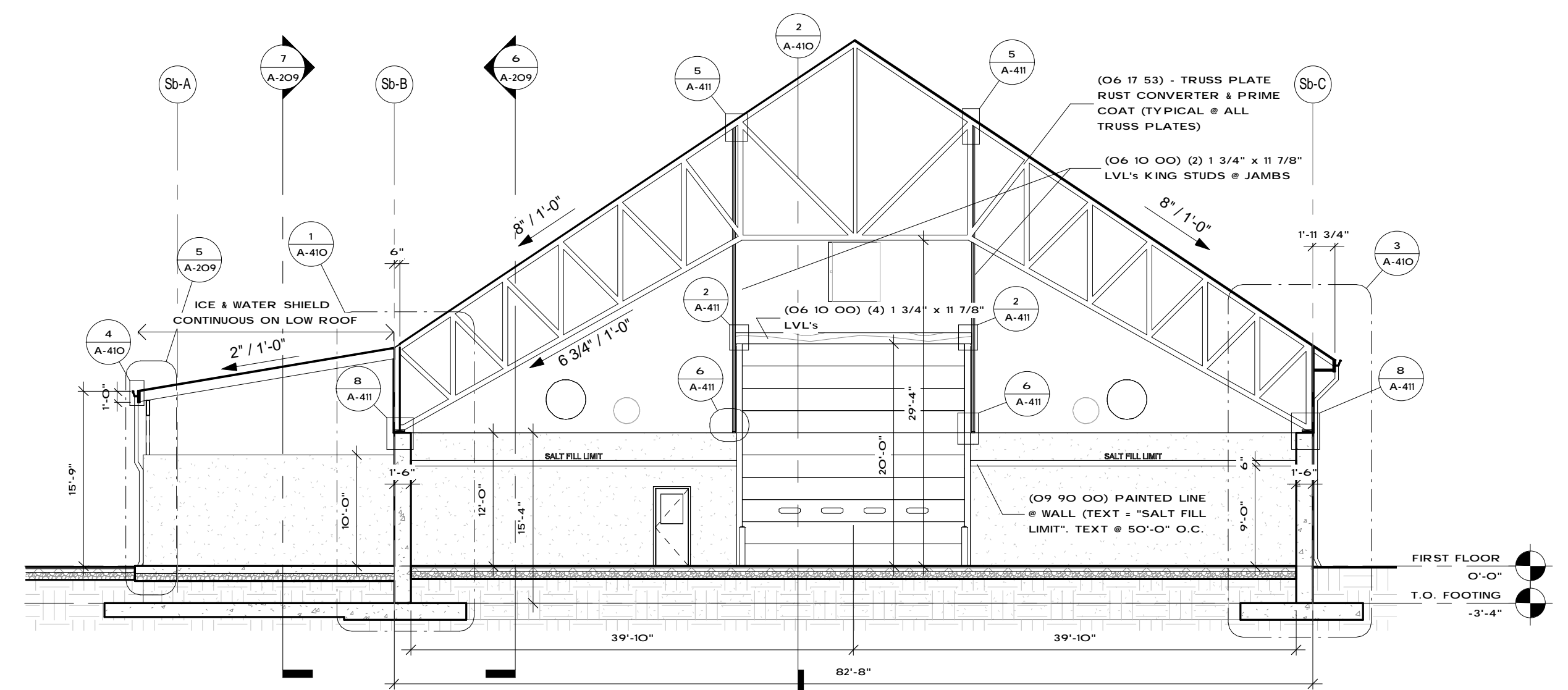

8 Salt Building - Section A-A
3/32" = 1'-0"

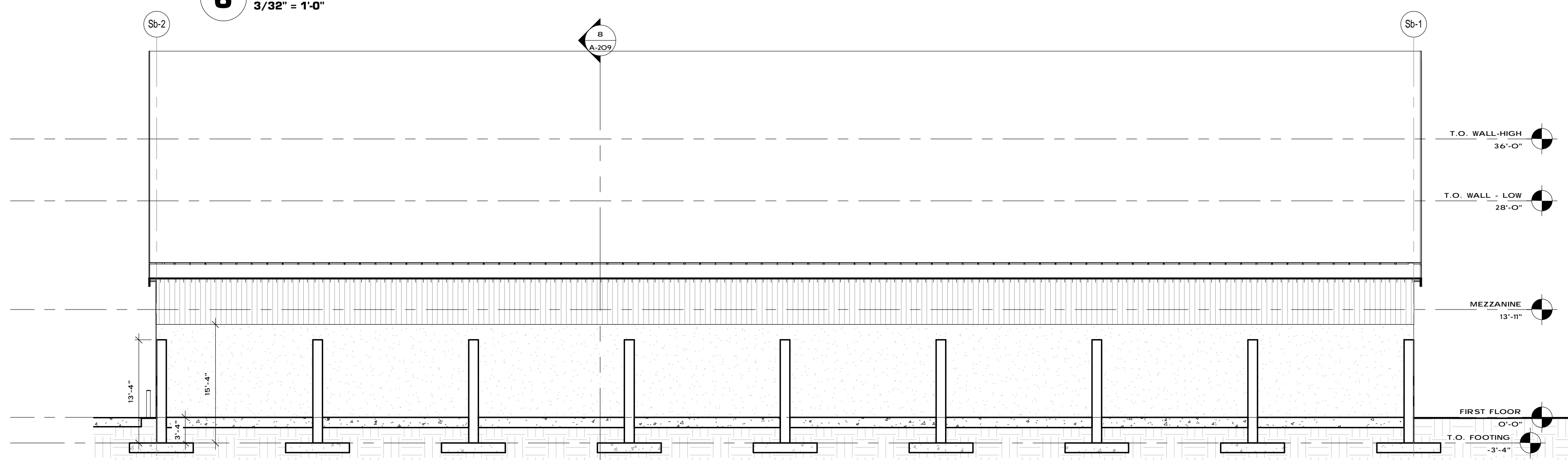

7 Salt Building - Section C-C
3/32" = 1'-0"

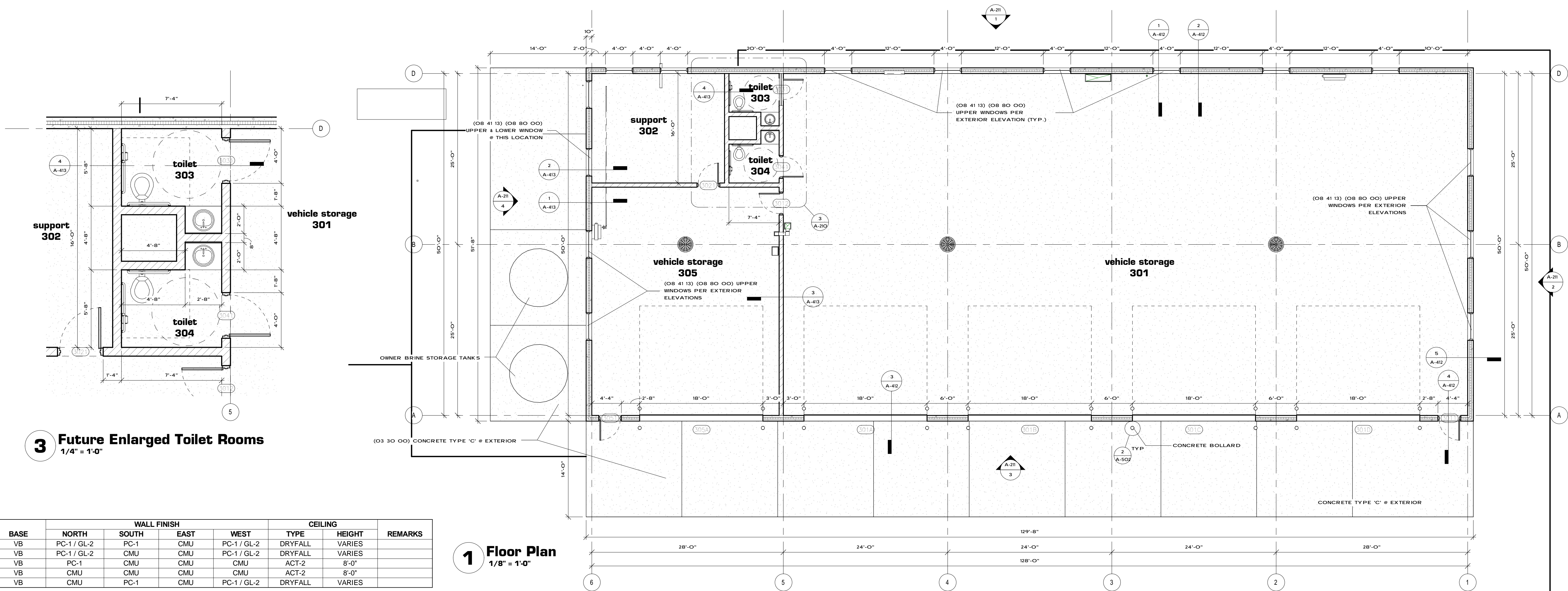

3 Future Enlarged Toilet Rooms
1/4" = 1'-0"

NUMBER	NAME	FLOOR TYPE	BASE	WALL FINISH				CEILING		REMARKS
				NORTH	SOUTH	EAST	WEST	TYPE	HEIGHT	
301	vehicle storage	CONC	VB	PC-1 / GL-2	PC-1	CMU	PC-1 / GL-2	DRYFALL	VARIES	
302	support	CONC	VB	PC-1 / GL-2	CMU	CMU	PC-1 / GL-2	DRYFALL	VARIES	
303	toilet	CONC	VB	PC-1	CMU	CMU	CMU	ACT-2	8'-0"	
304	toilet	CONC	VB	CMU	CMU	CMU	CMU	ACT-2	8'-0"	
305	vehicle storage	CONC	VB	CMU	PC-1	CMU	PC-1 / GL-2	DRYFALL	VARIES	

1 Floor Plan
1/8" = 1'-0"

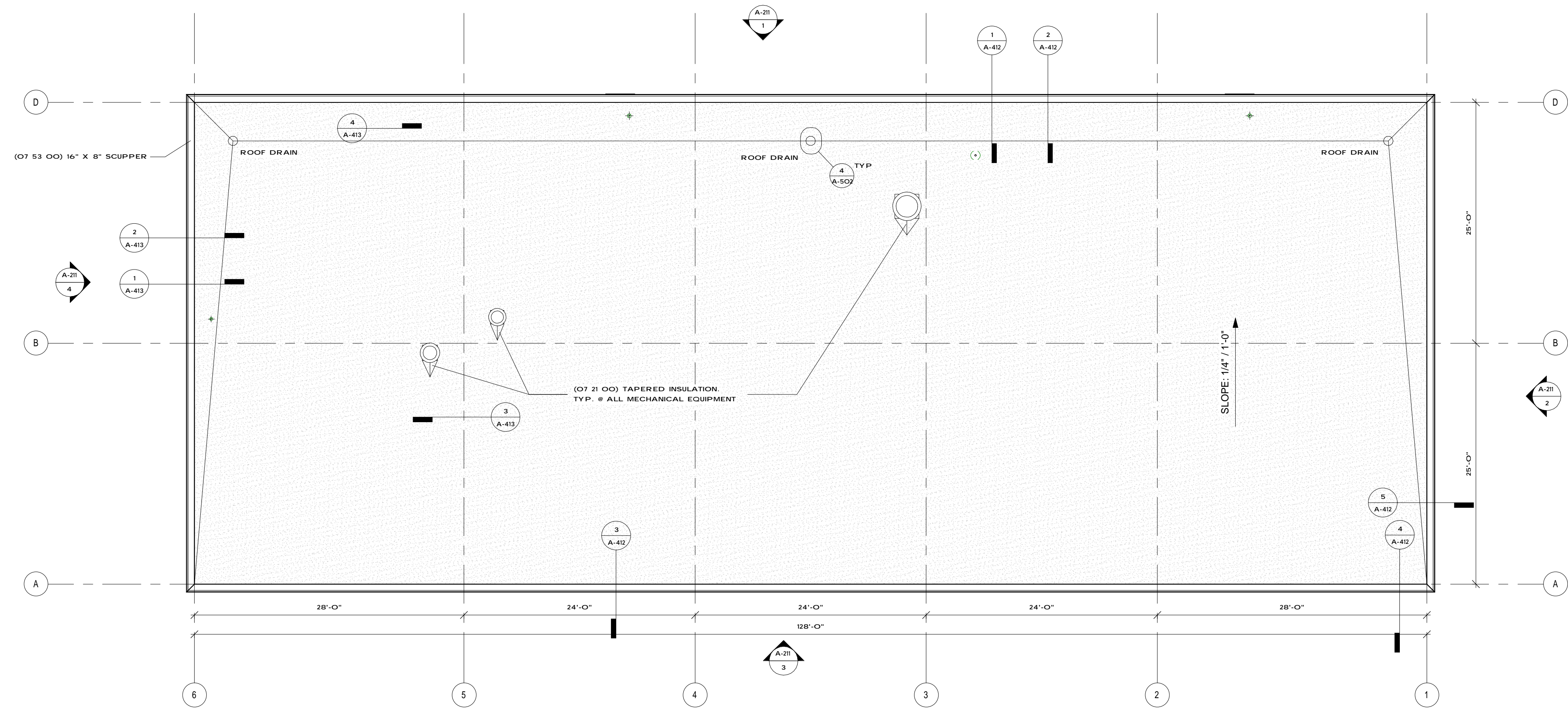

2 Roof Plan
1/8" = 1'-0"

Satellite Building - Floor Plan and Roof Plan

kuenyarch.com ©2015 Kueny Architects L.L.C. - All Rights Reserved
Dane County - Highway Facility Satellite Building
US 151 and County Highway V
January 12, 2015

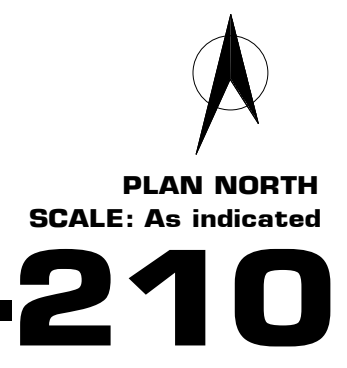

A-210

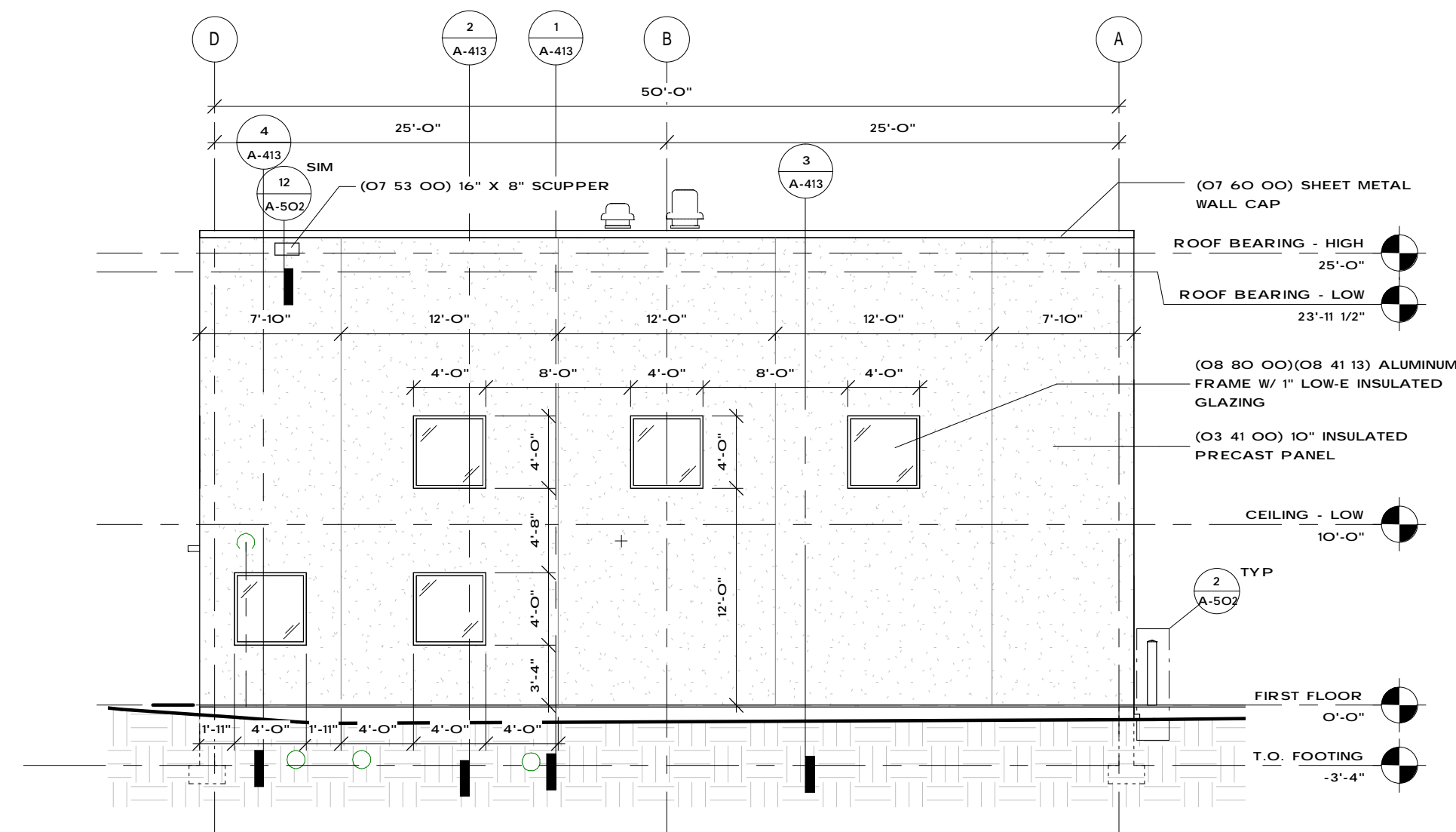

4 West Elevation
1/8" = 1'-0"

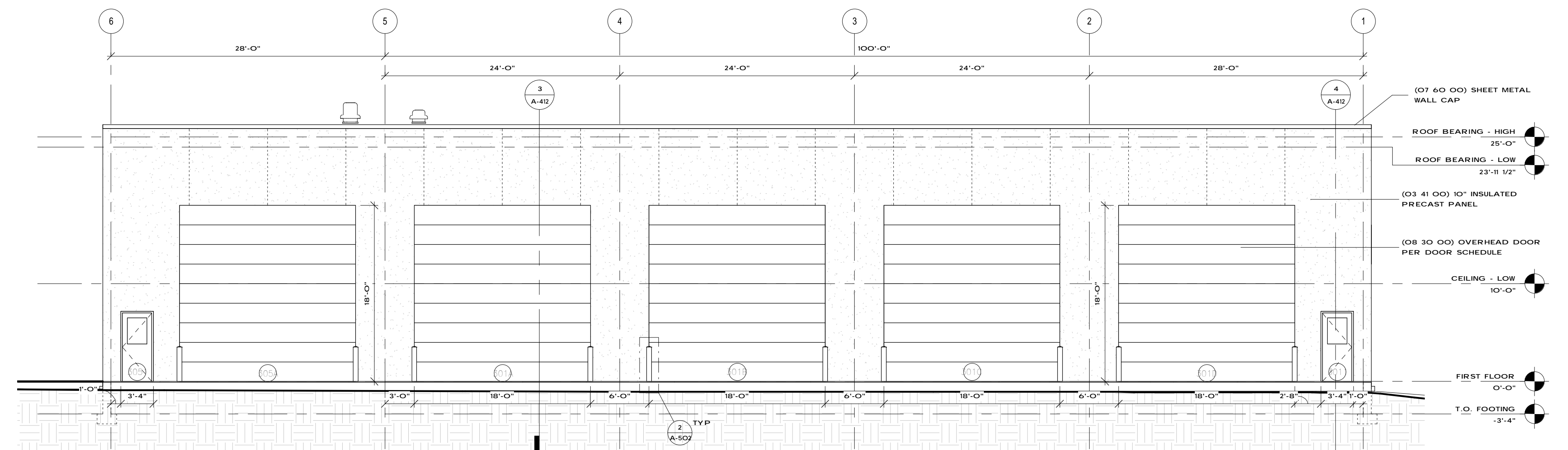

3 South Elevation
1/8" = 1'-0"

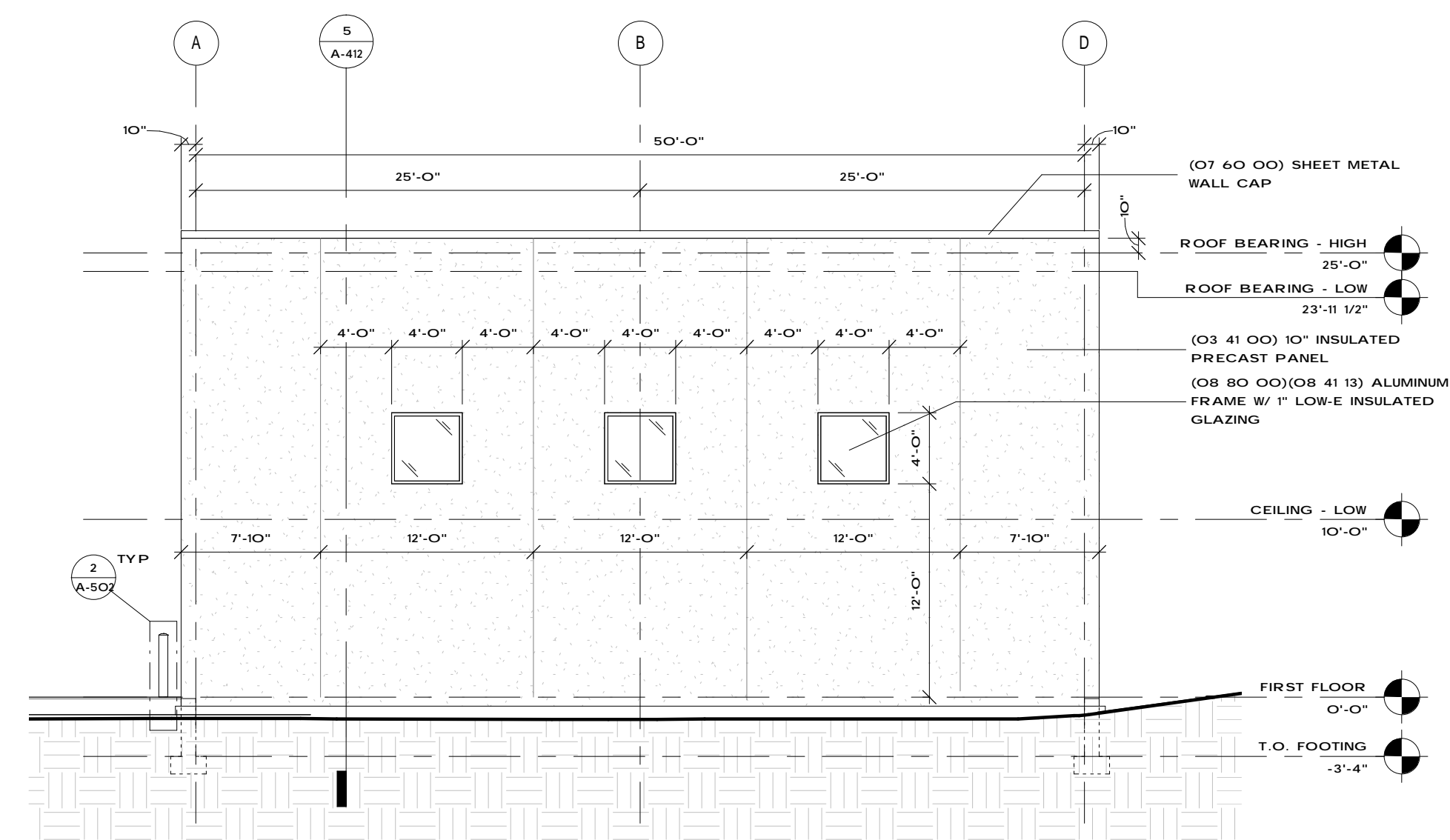

2 East Elevation
1/8" = 1'-0"

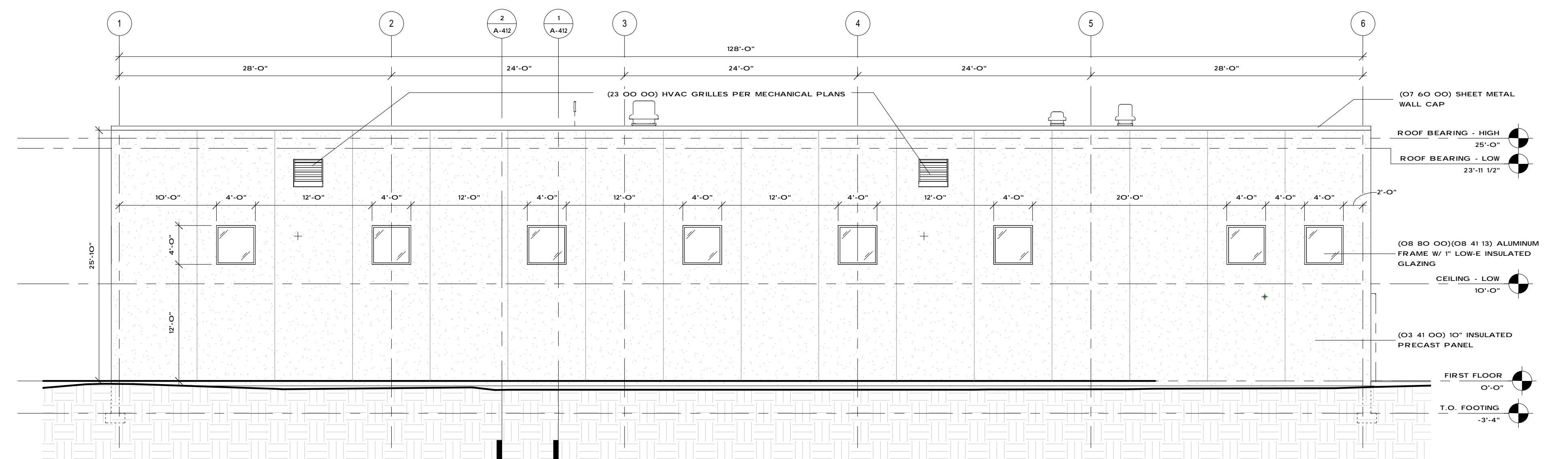

1 North Elevation
1/8" = 1'-0"

5 Pump House - South Elevation
1/4" = 1'-0"

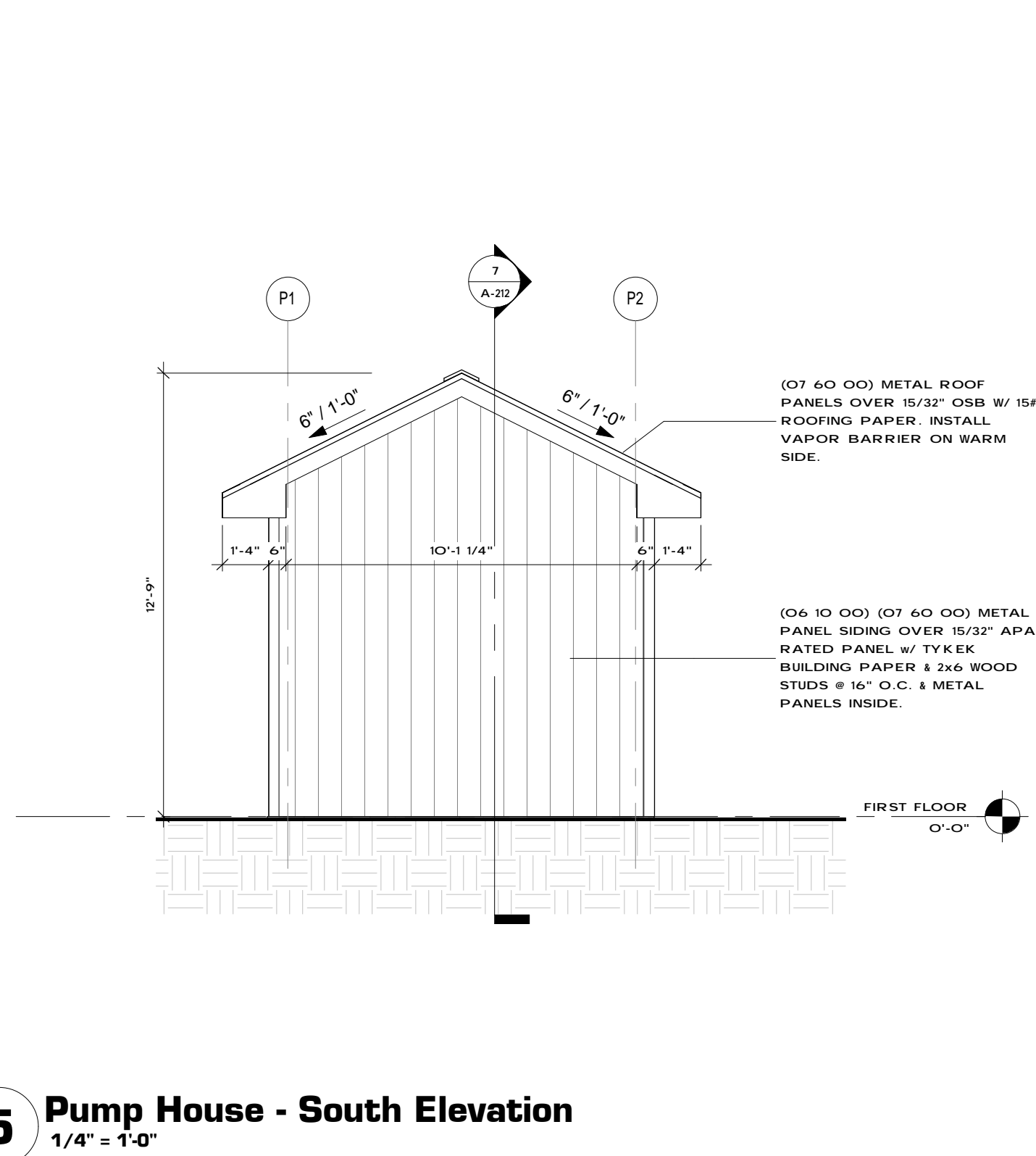

4 Pump House - Framing Plan
1/4" = 1'-0"

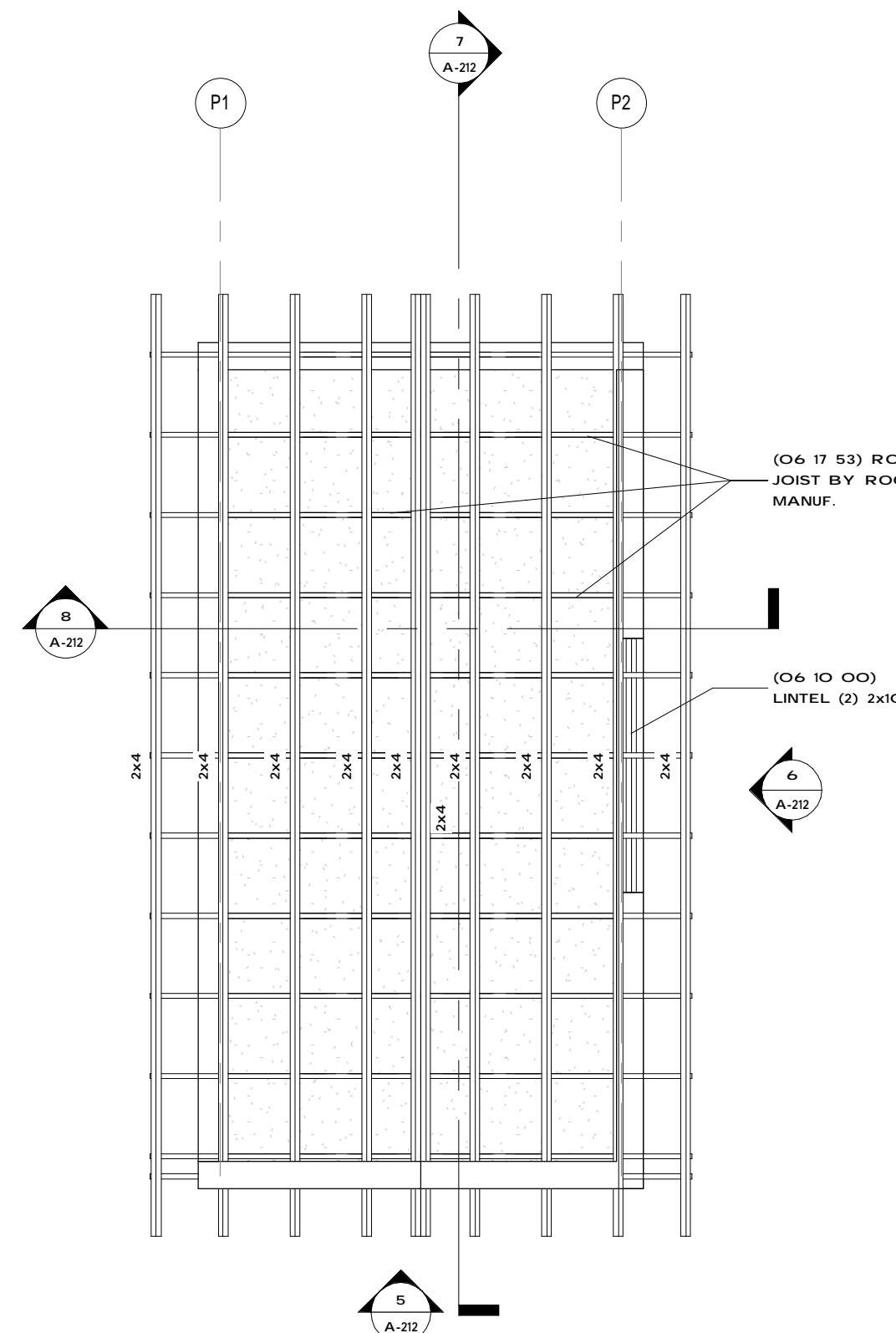

3 Pump House - Roof Plan
1/4" = 1'-0"

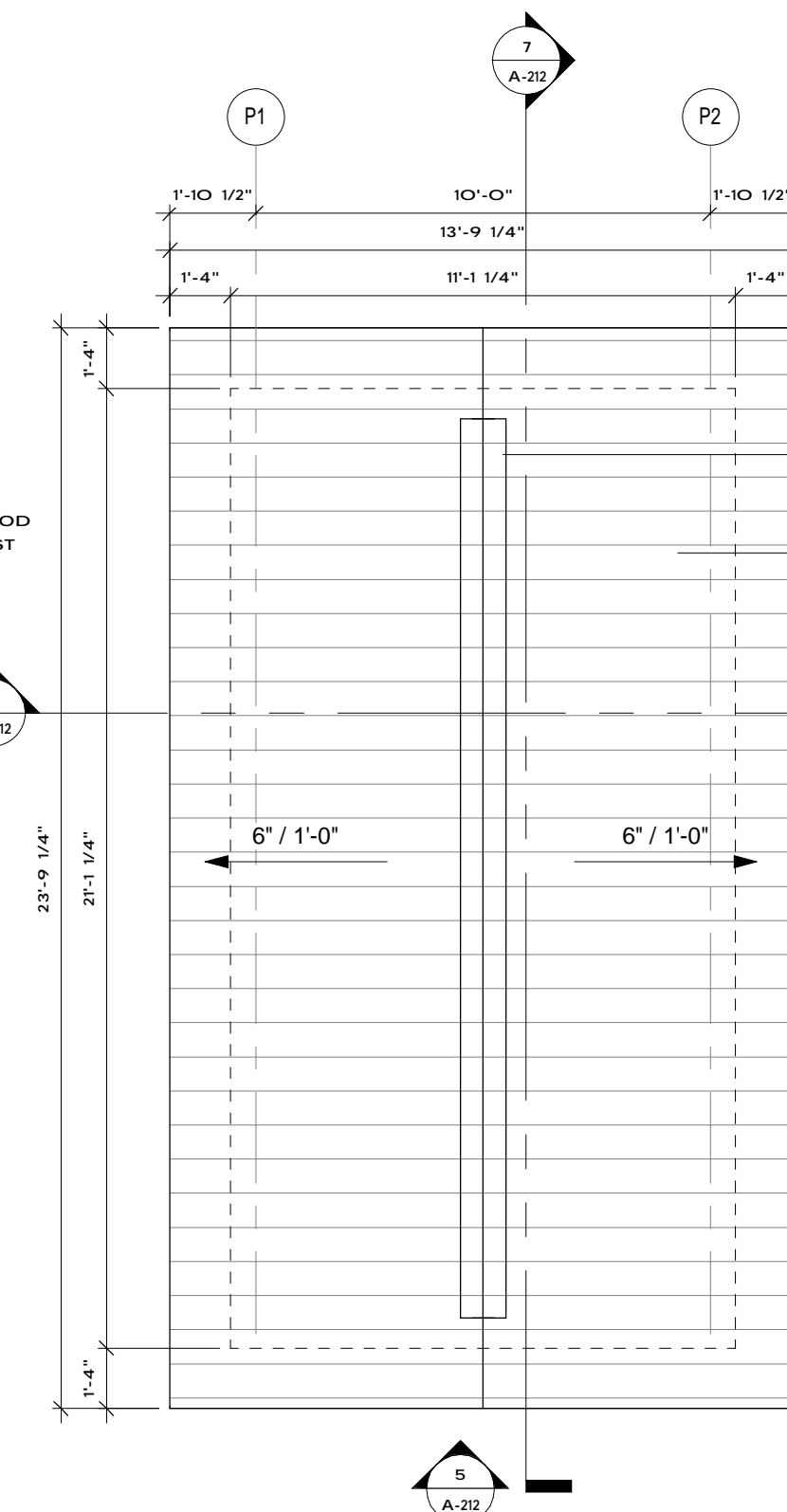

2 Pump House - Foundation Plan
1/4" = 1'-0"

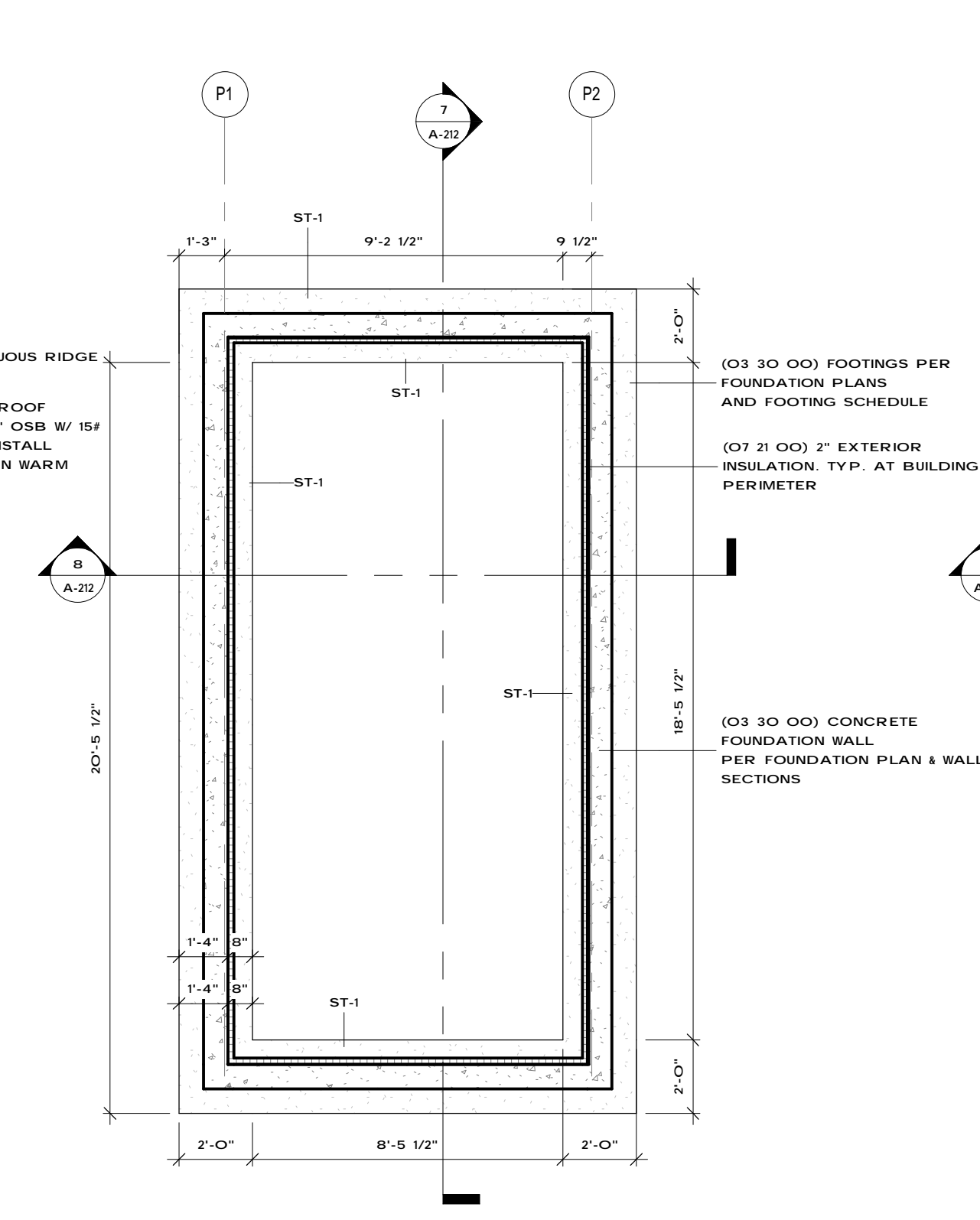

1 Pump House - Floor Plan
1/4" = 1'-0"

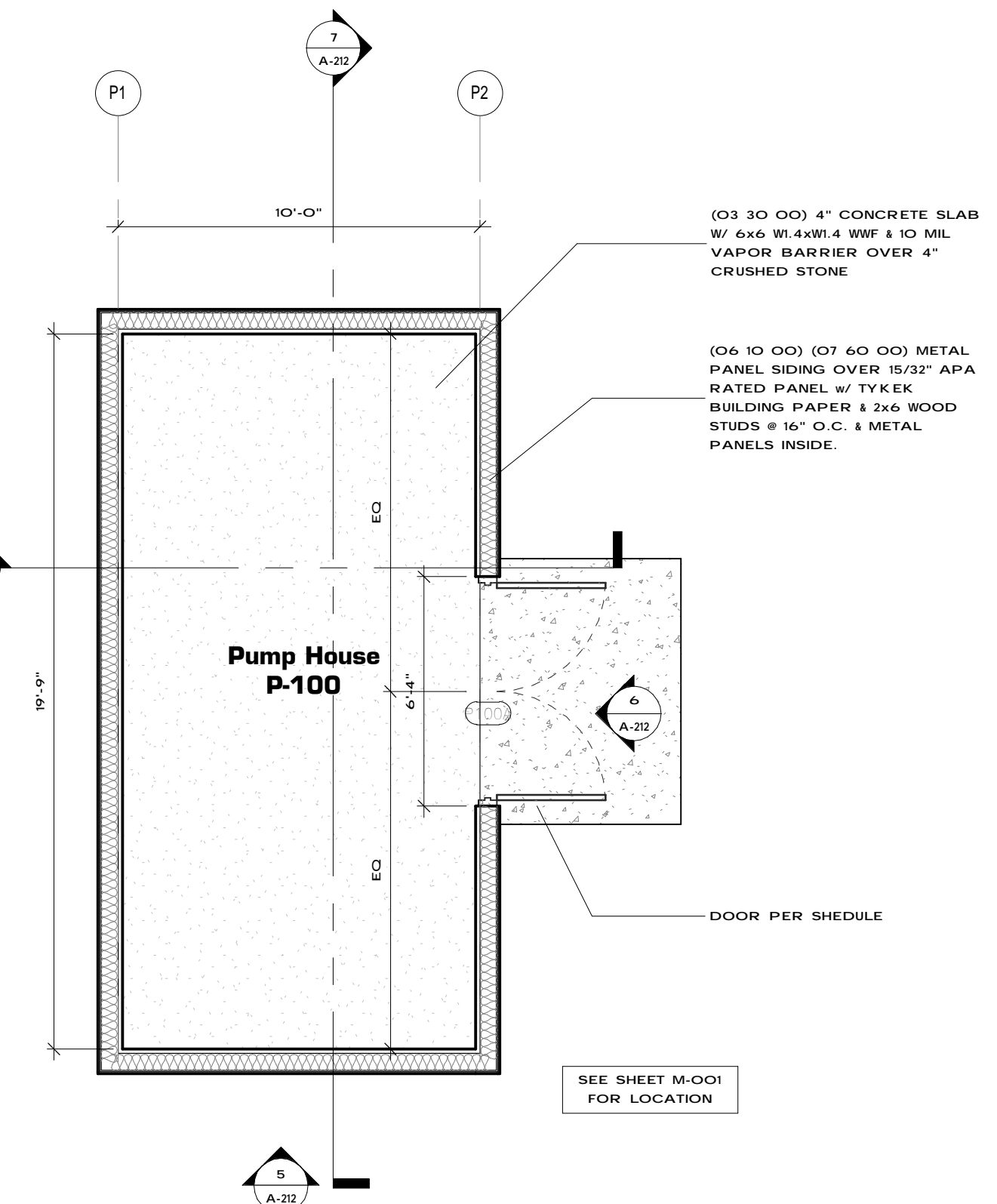

6 Pump House - East Elevation
1/4" = 1'-0"

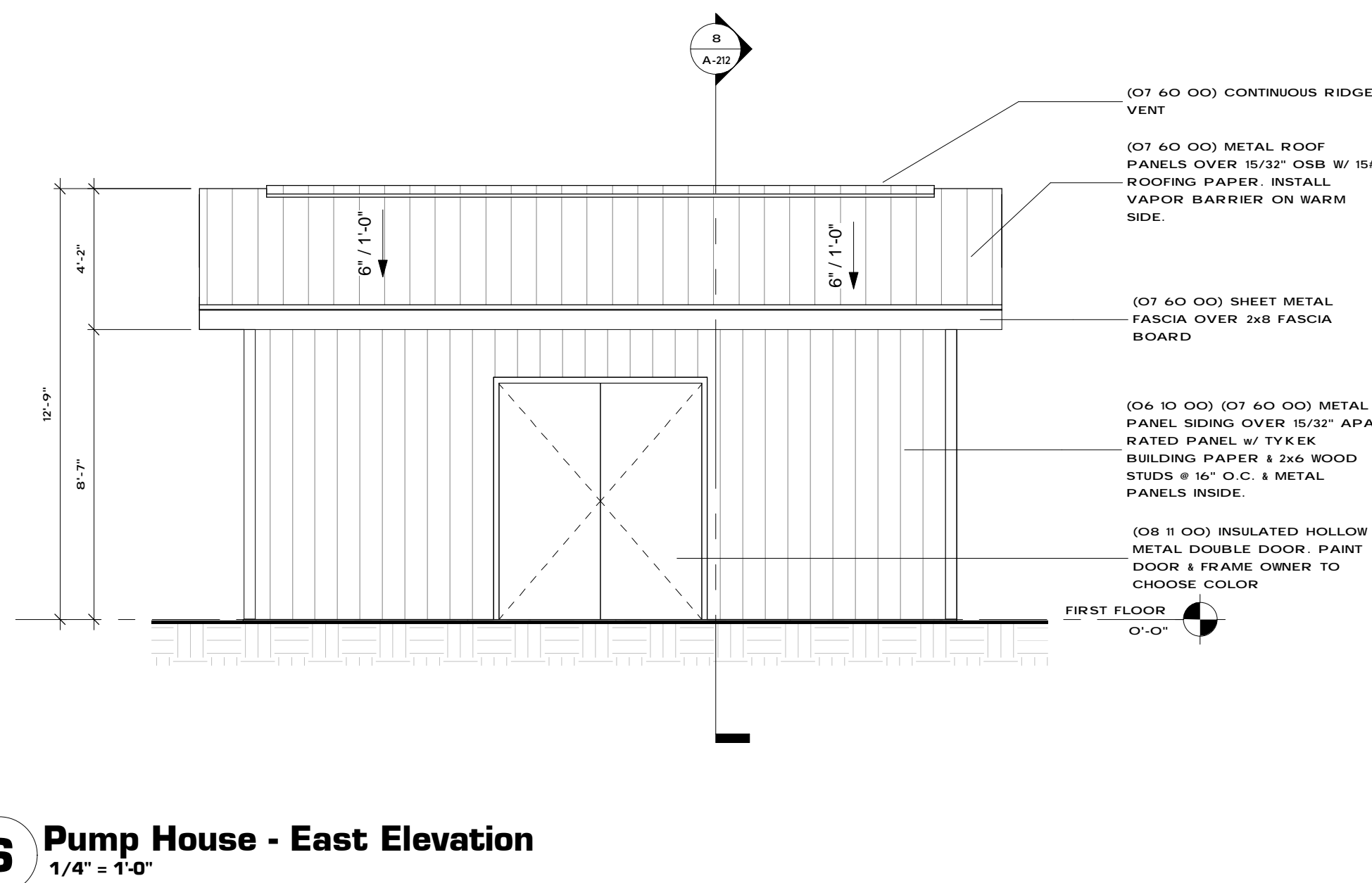

7 Pump House - Section 2
1/4" = 1'-0"

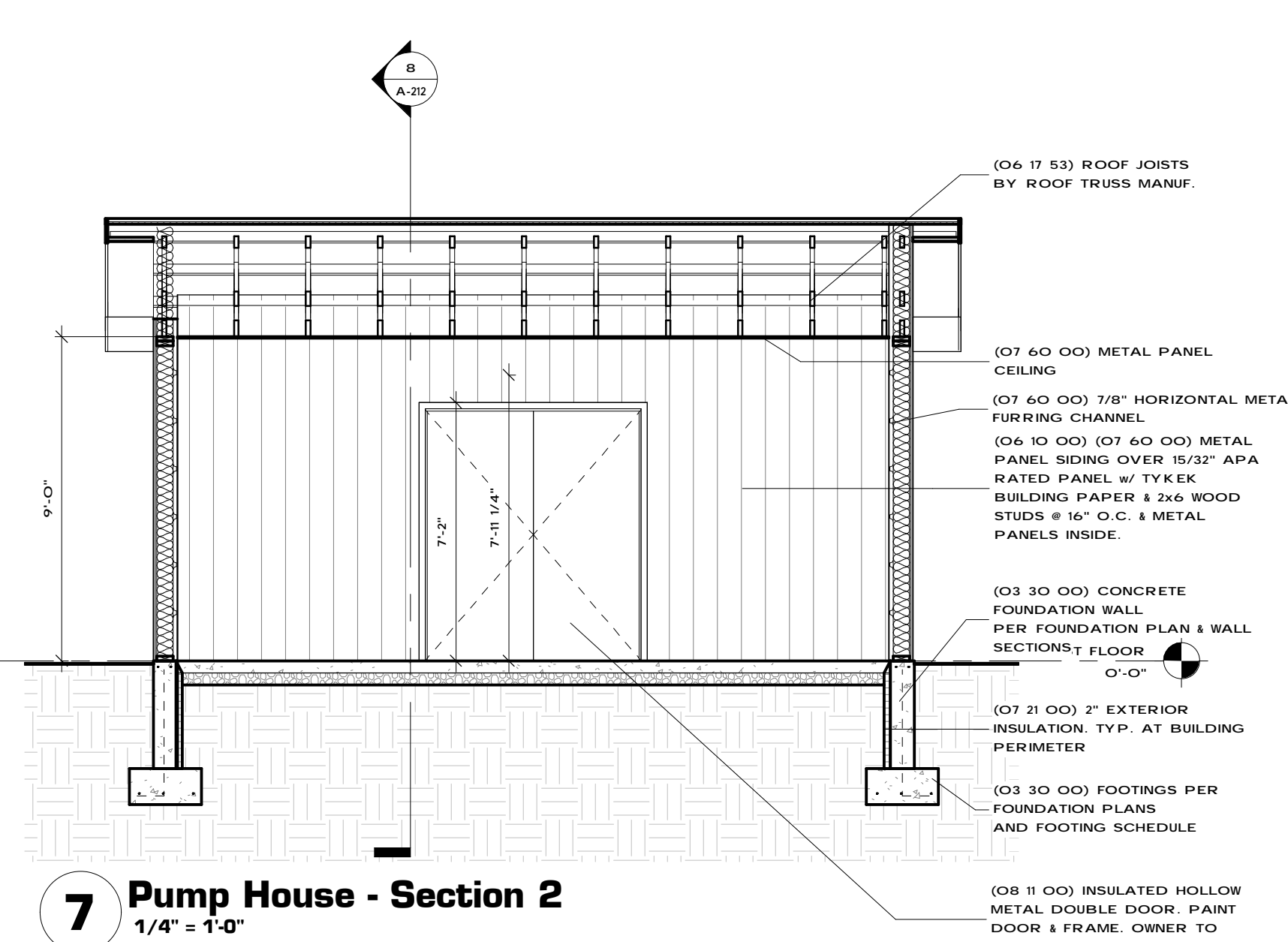

8 Pump House - Section 1
1/2" = 1'-0"

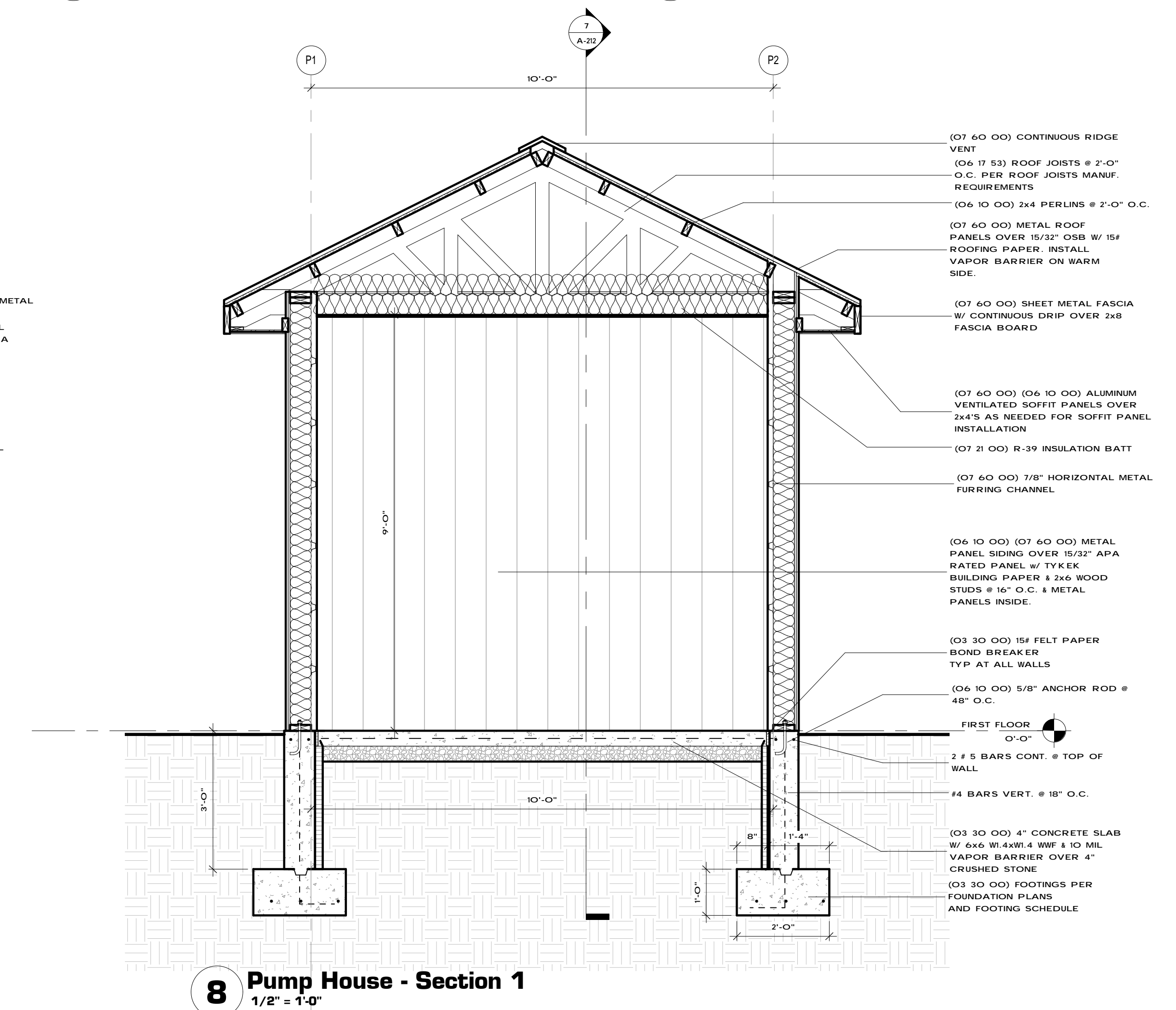

PUMP HOUSE - DOOR SCHEDULE																		
MARK	FROM ROOM		TO ROOM		DOOR							FRAME				REMARKS		
	NUM	NAME	NUM	NAME	TYPE	MATERIAL	SWING	LABEL	WIDTH	HEIGHT	THICKNESS	LOUVER	GLASS	TYPE	MATERIAL		LABEL	GLASS
P100A	-	exterior	P-100	Pump House	F (2)	METAL	L/RHRB	-	3'-0"	7'-0"	1 3/4"	-	-	E	-	-	-	-

PUMP HOUSE - HARDWARE SCHEDULE													
MARK	LOCKSET	PUSH-PULL	HOLD OPEN	CLOSER	HINGE	DOOR STOP	THRESHOLD	WEATHERSTRIP	KICKPLATE	SOUNDSTOP	NAMEPLATE	NOTES	
P100A	Entrance	-	-	-	X	-	X	X	-	-	-	(3) Left hand inactive with flush bolts / (4) Handle on inactive door	

PUMP HOUSE - ROOM SCHEDULE											
NUMBER	NAME	FLOOR TYPE	BASE	WALL FINISH				CEILING			REMARKS
				NORTH	SOUTH	EAST	WEST	TYPE	HEIGHT		
P-100	Pump House	Concrete	-	Metal Panel	Metal Panel	Metal Panel	Metal Panel	Metal Panel	9'-0"	-	

Pump House - Floor Plans, Sections, & Details

kuenyarch.com ©2015 Kueny Architects L.L.C. - All Rights Reserved
Dane County - Dane County Highway Facility
3562 County Highway AB, Cottage Grove, WI 53558
January 12, 2015



A-212

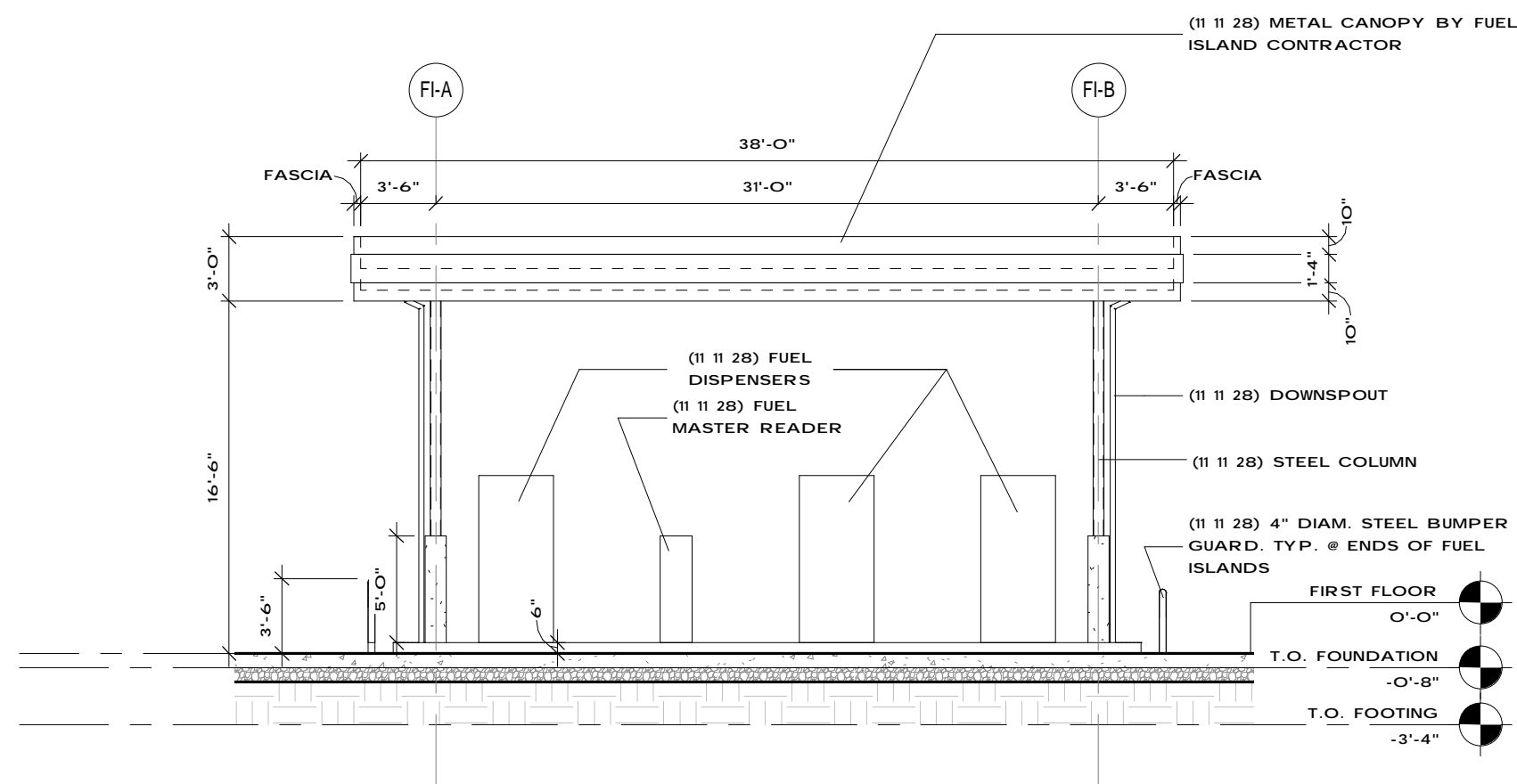

4 Fuel Island - West Elevation
1/8" = 1'-0"

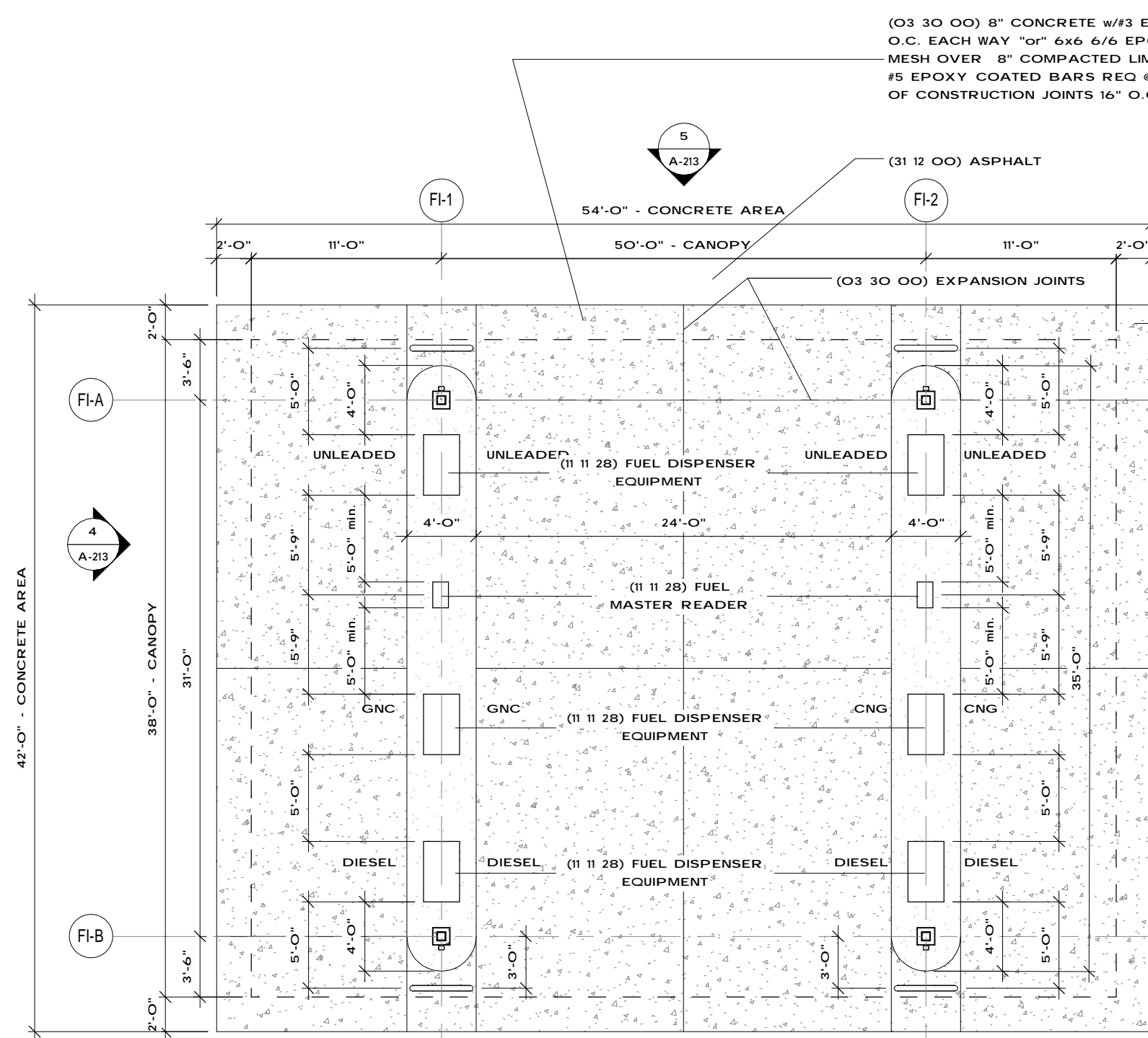

2 Fuel Island Floor Plan
1/8" = 1'-0"

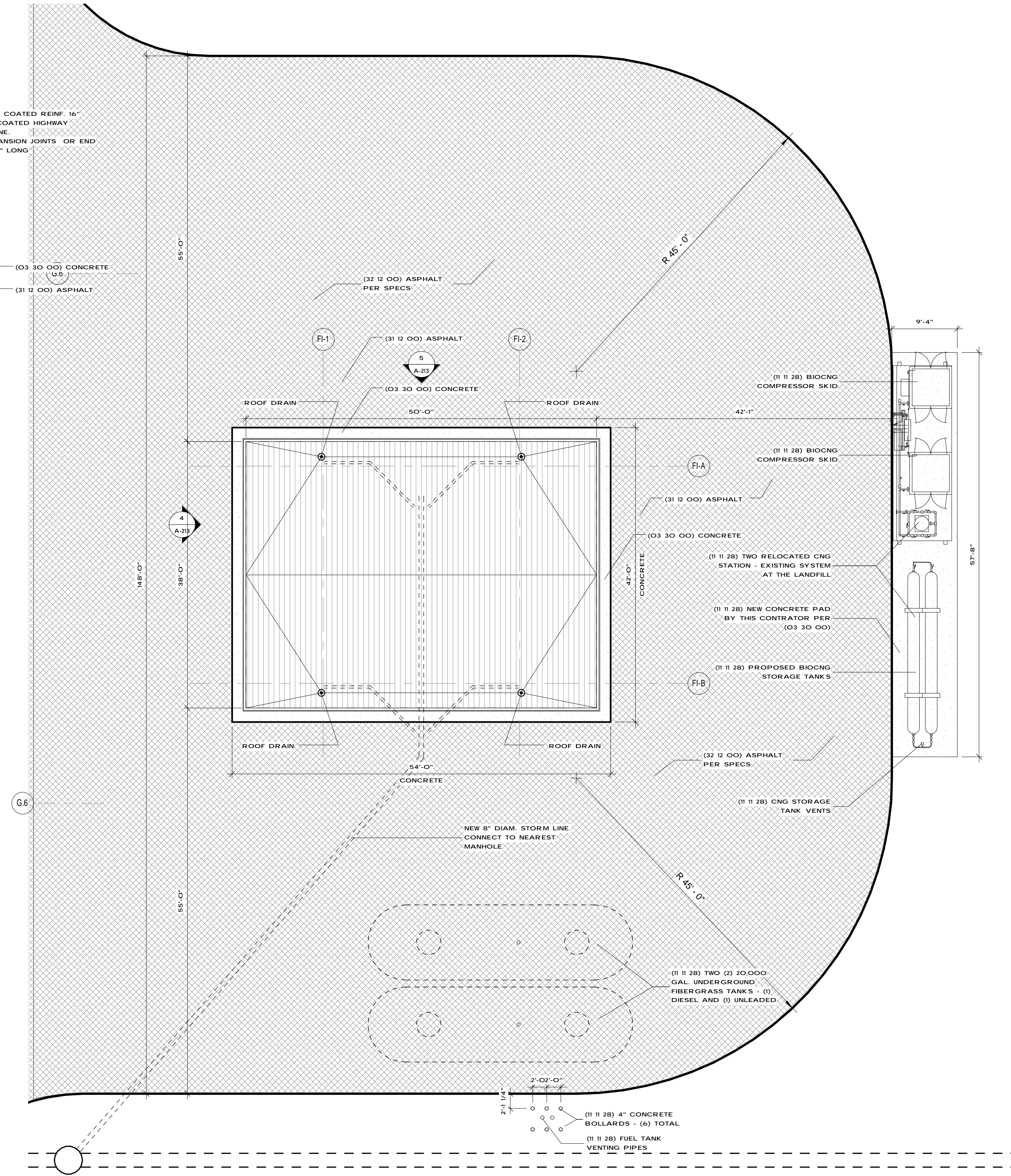

1 Fuel Island Site Plan
1" = 10'-0"

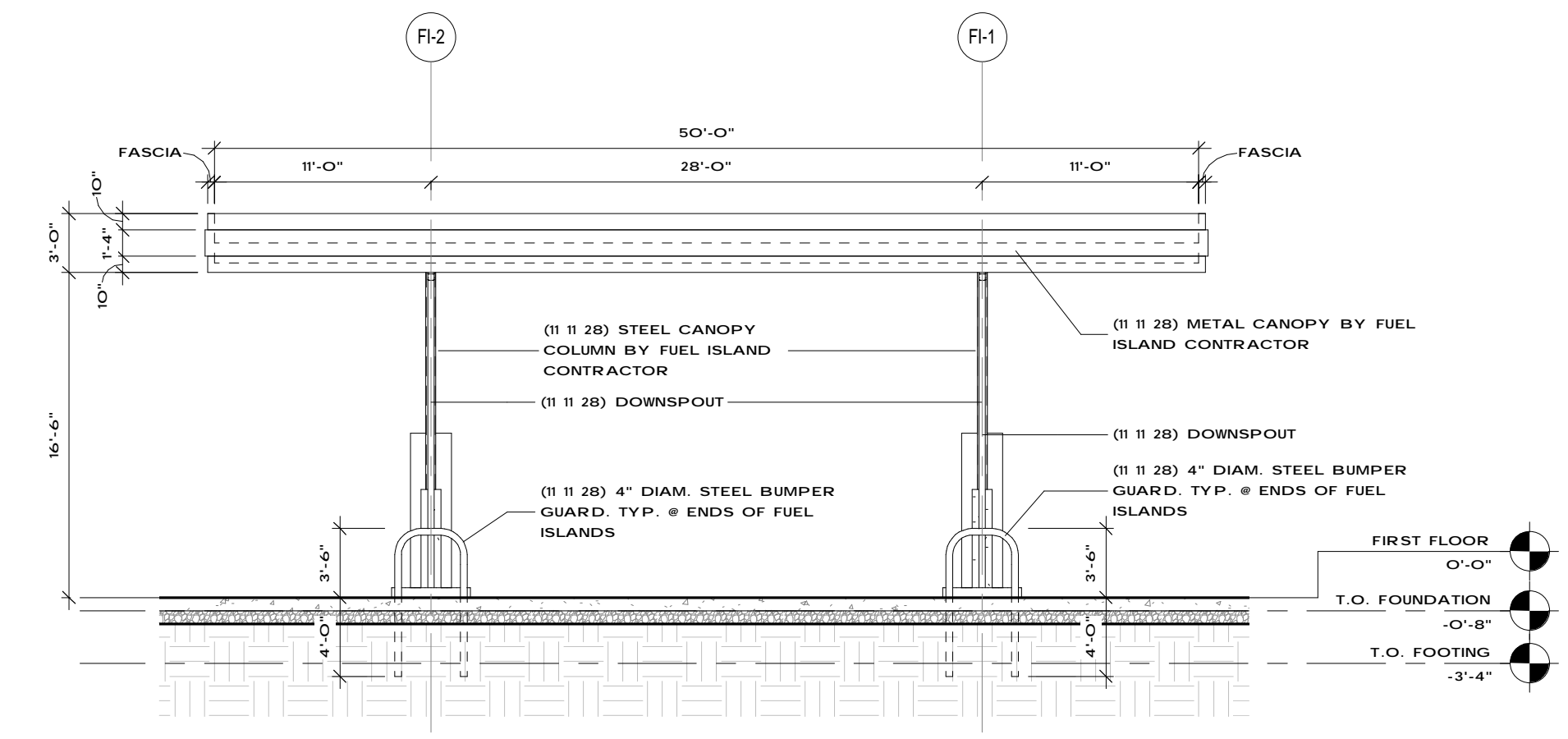

5 Fuel Island - North Elevation
1/8" = 1'-0"

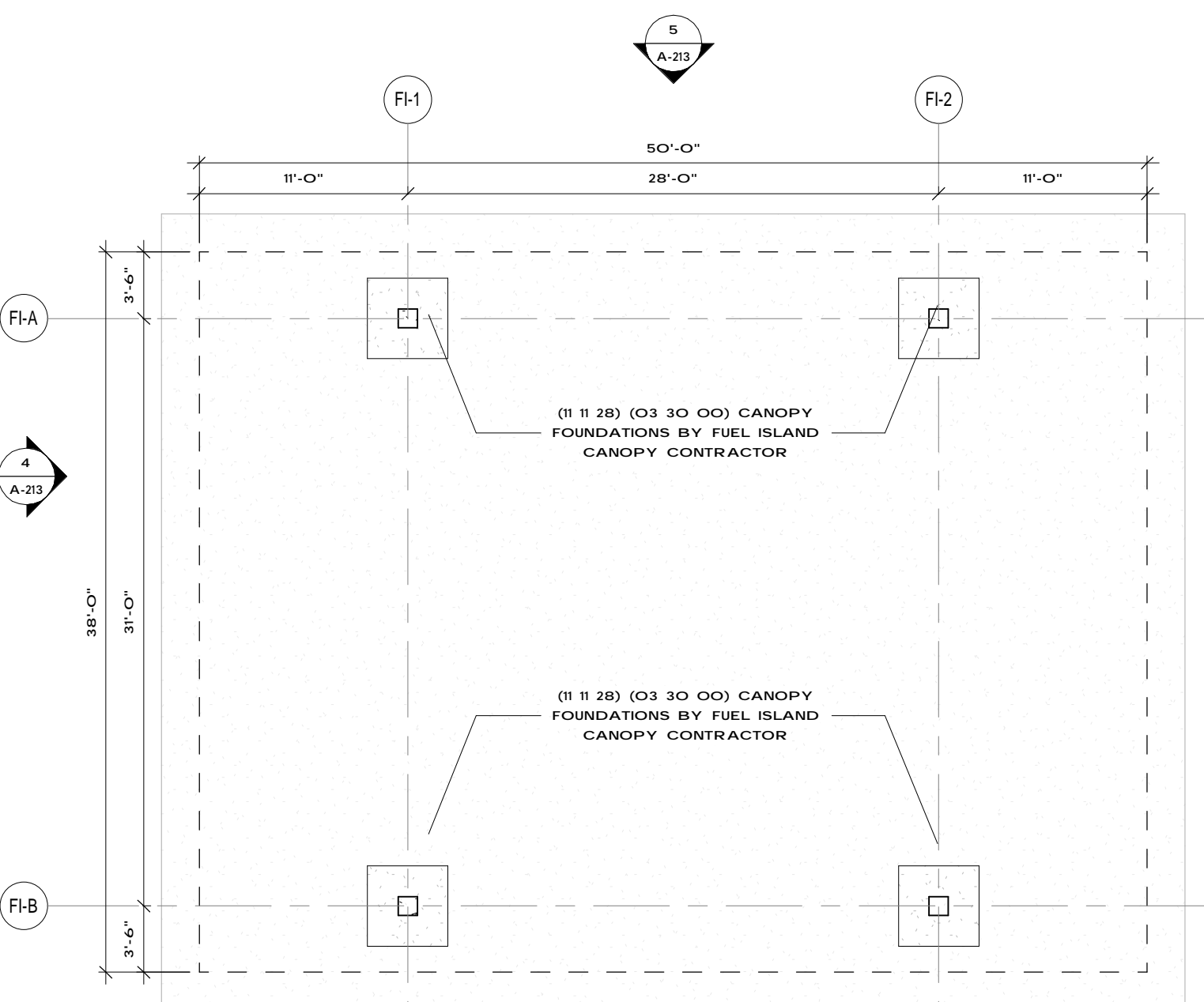

3 Fuel Island Foundation Plan
1/8" = 1'-0"

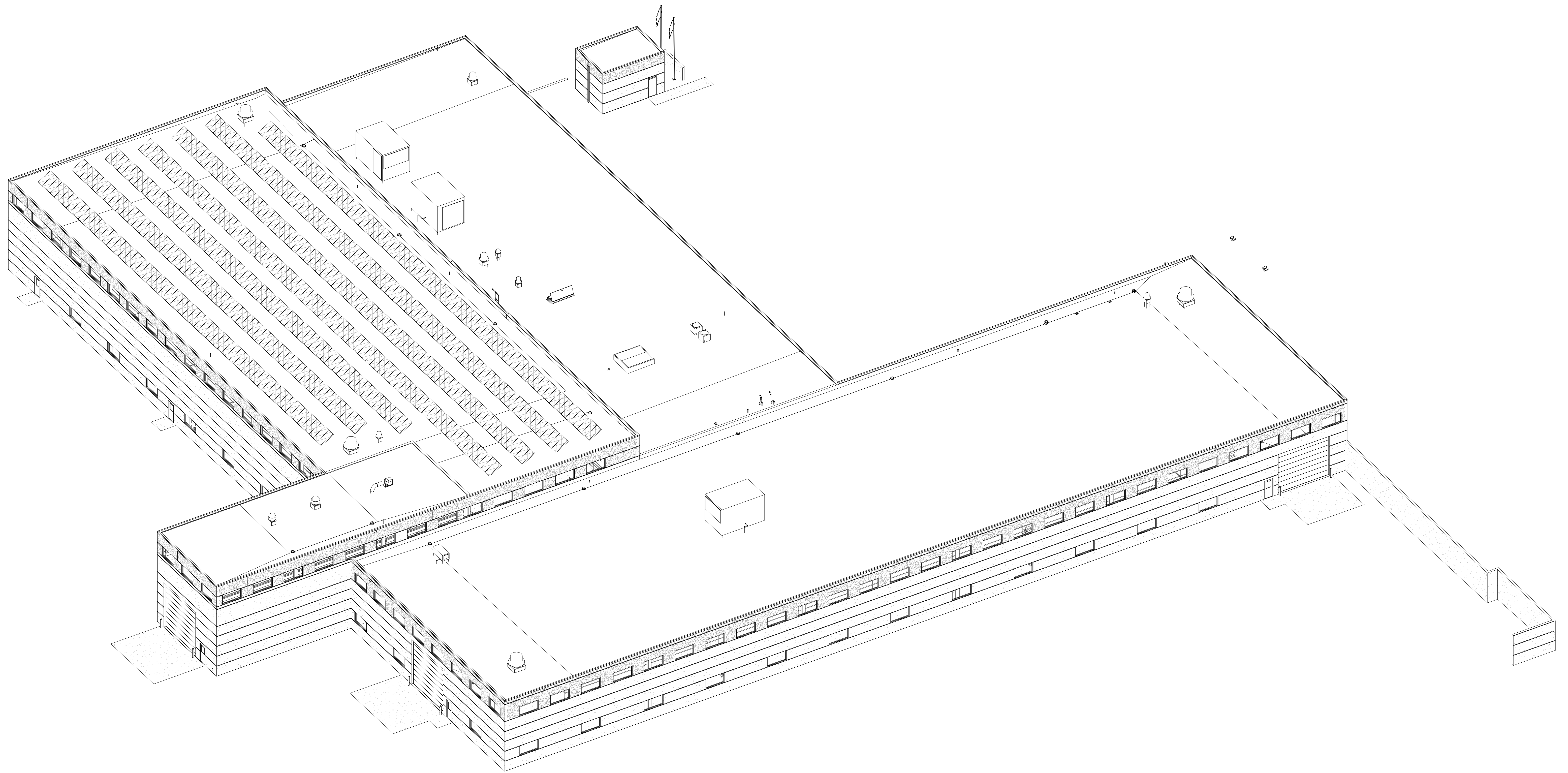

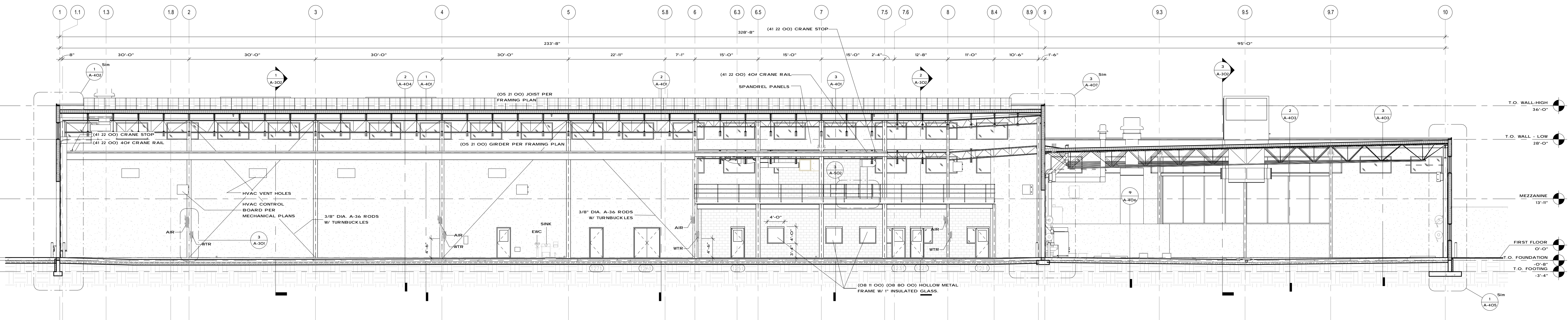

1 West-East Building Section
3/32" = 1'-0"

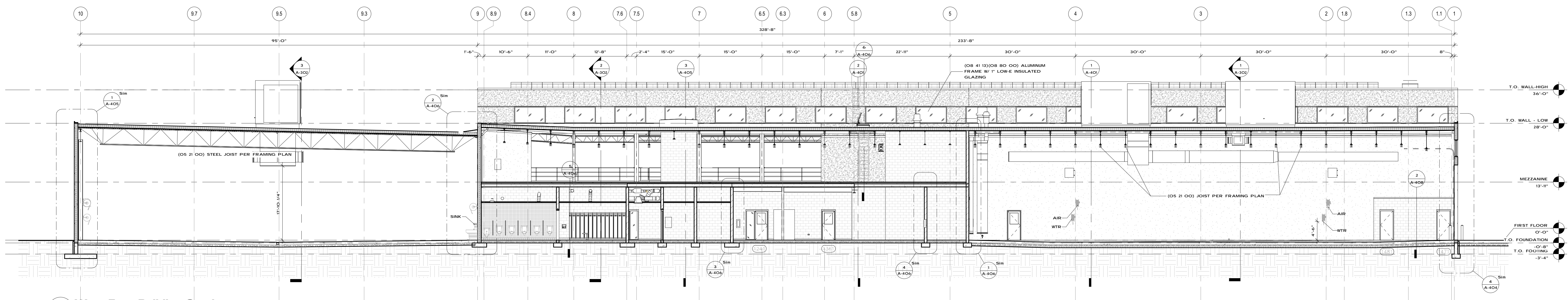

2 West-East Building Section
3/32" = 1'-0"

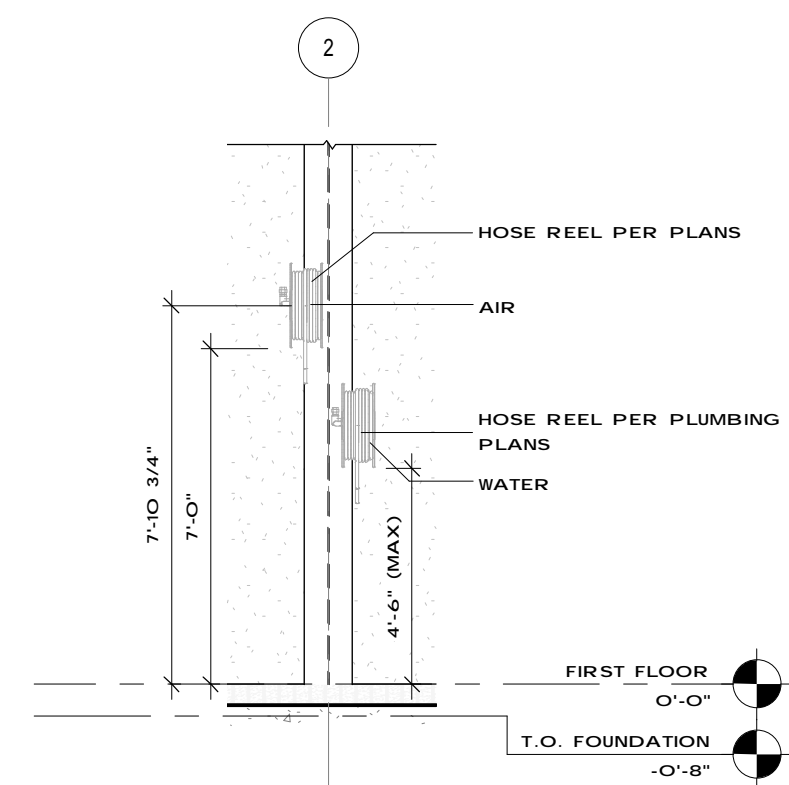

3 Typ. Air & Water Reel Elevation
1/4" = 1'-0"

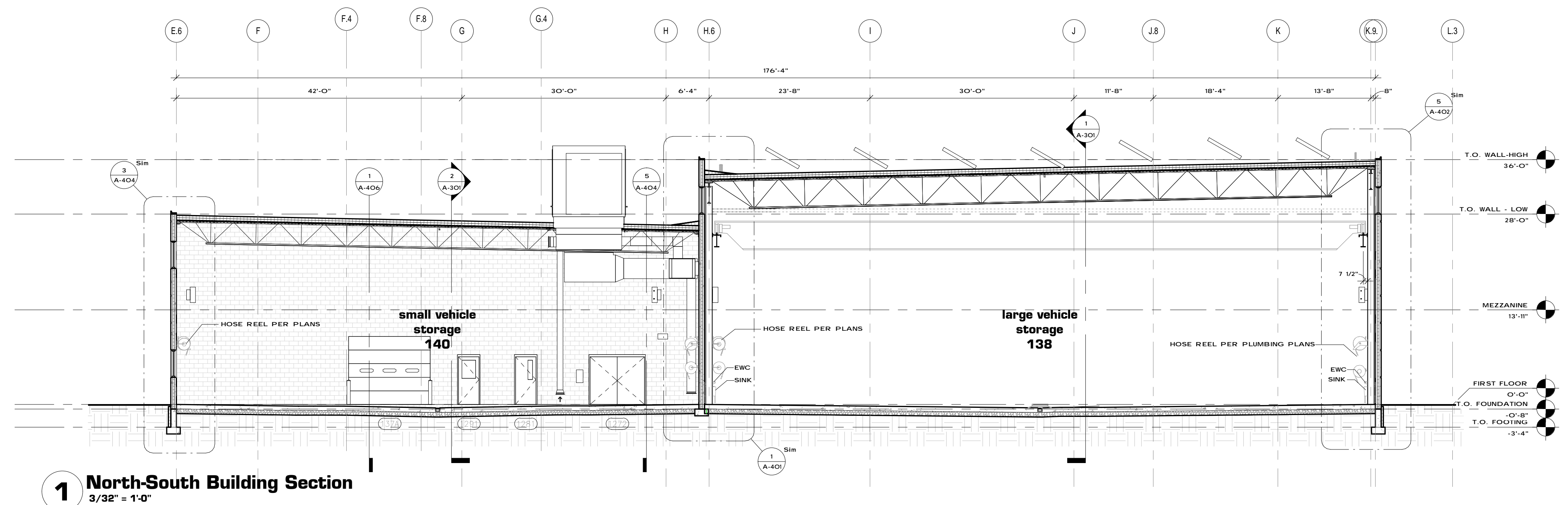

1 North-South Building Section
3/32" = 1'-0"

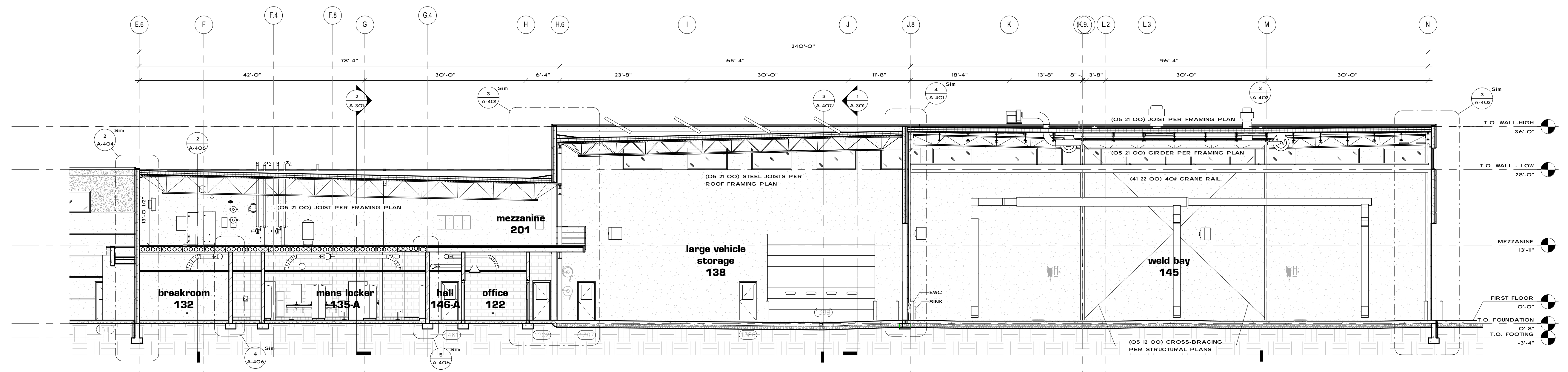

2 North-South Building Section
3/32" = 1'-0"

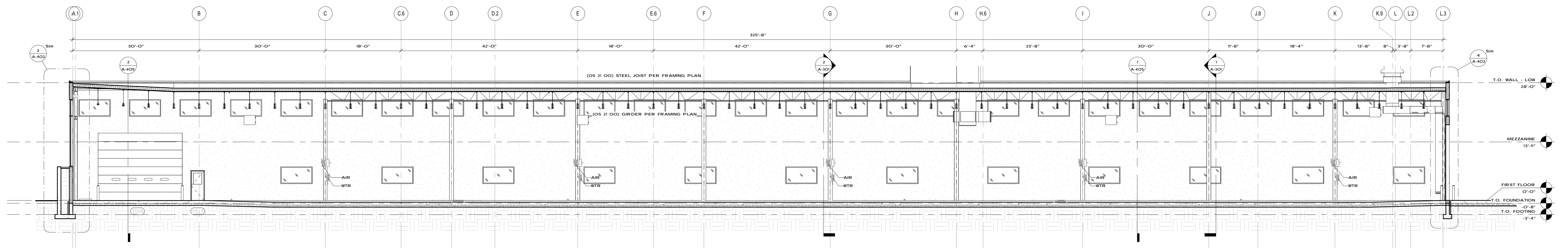

3 North-South Building Section
3/32" = 1'-0"

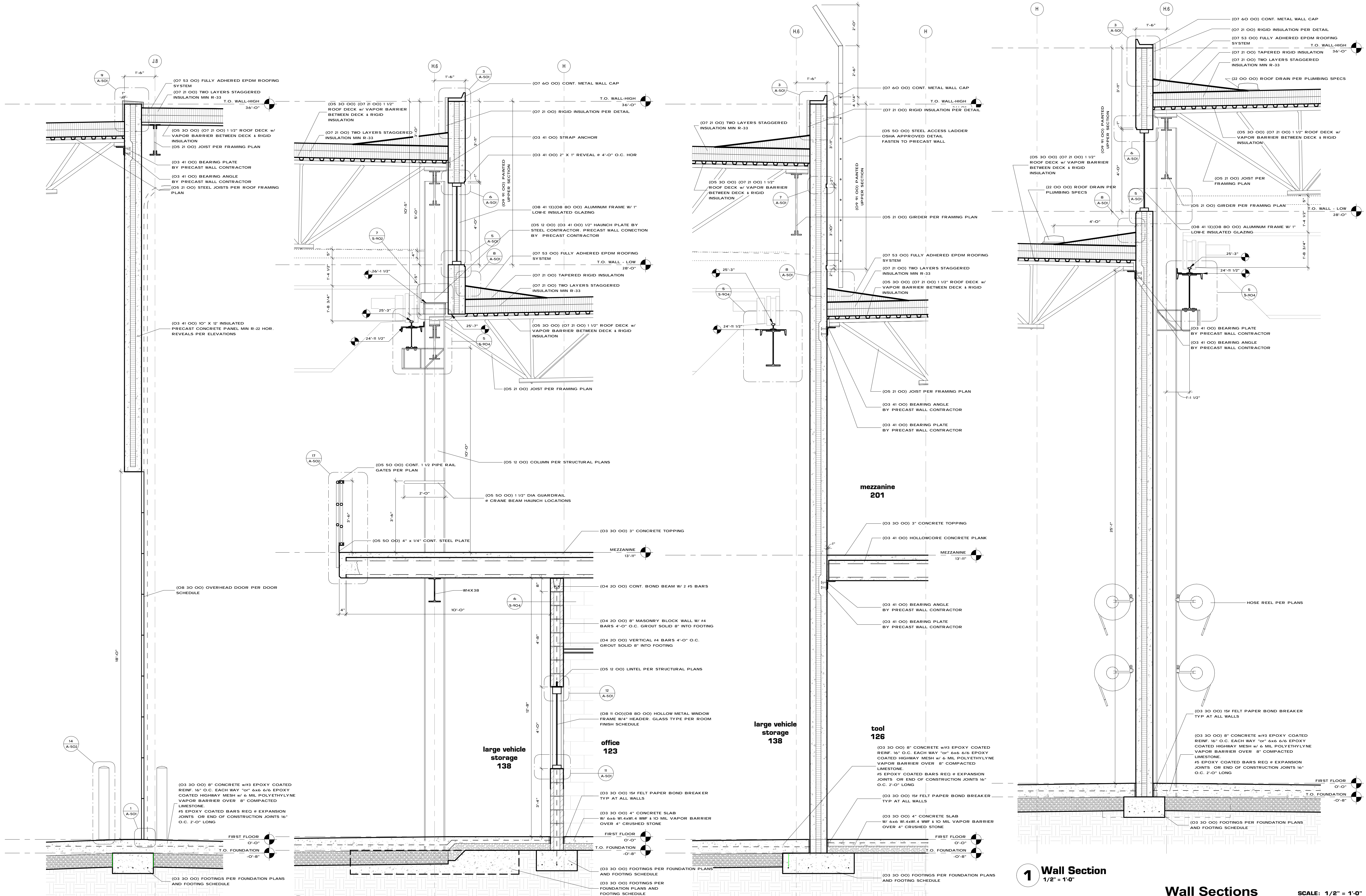

4 Wall Section
1/2" = 1'-0"

3 Wall Section
1/2" = 1'-0"

2 Wall Section
1/2" = 1'-0"

1 Wall Section
1/2" = 1'-0"

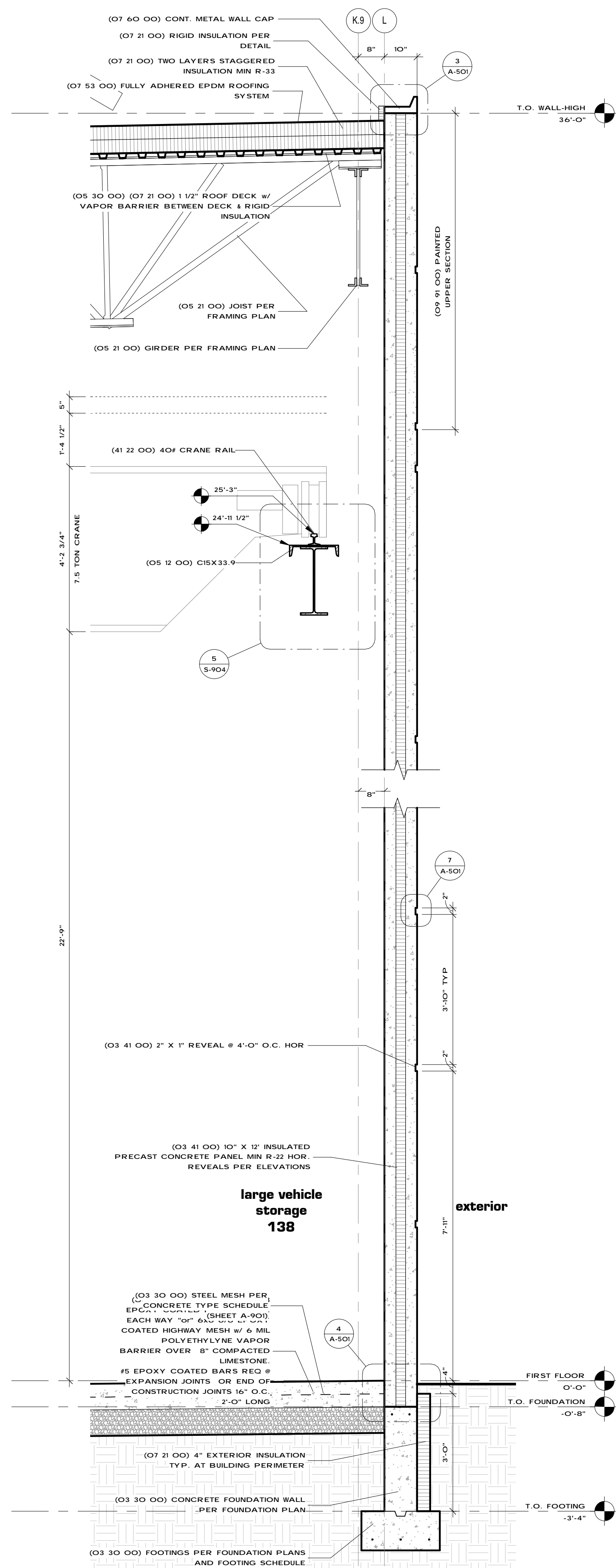

5 Wall Section
1/2" = 1'-0"

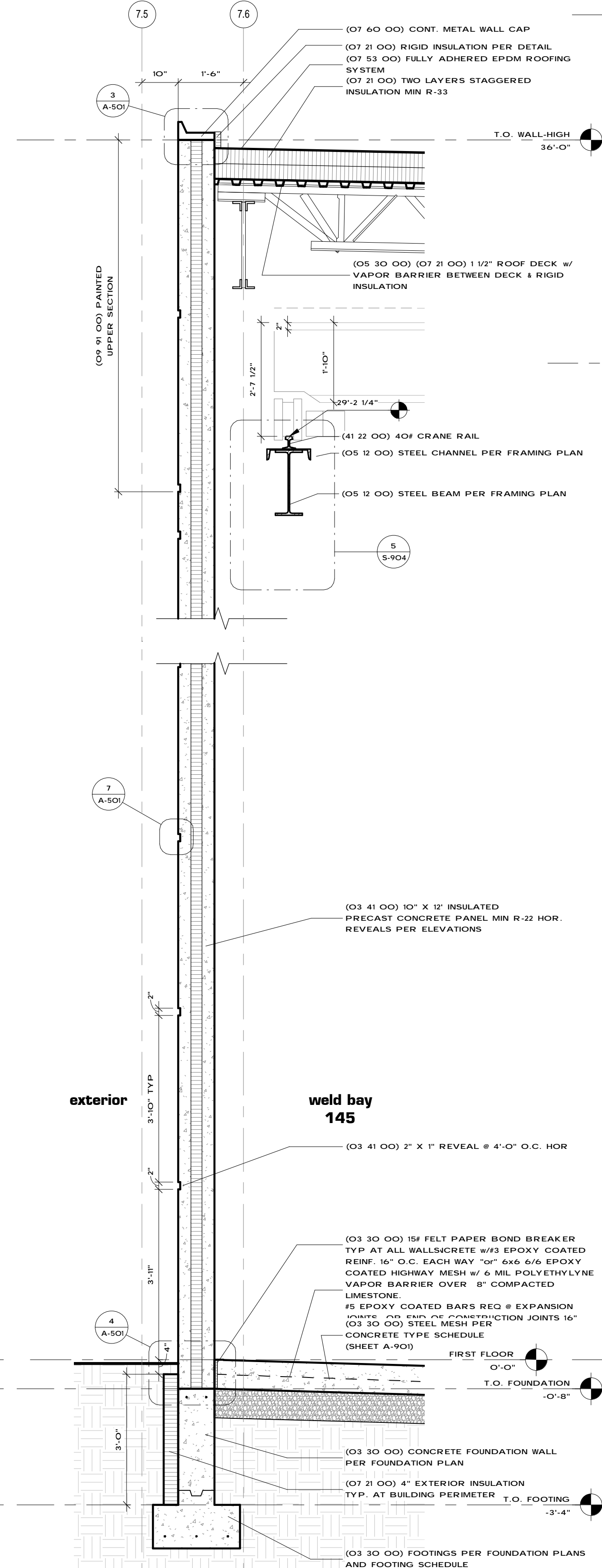

4 Wall Section
1/2" = 1'-0"

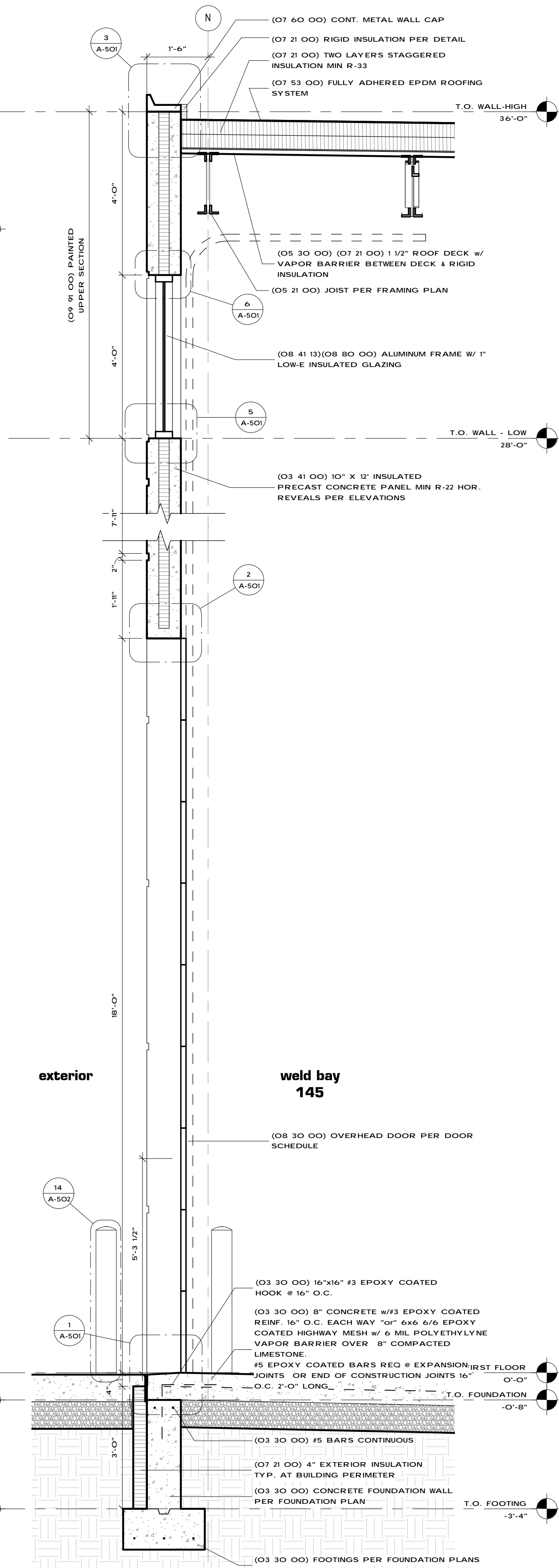

3 Wall Section
1/2" = 1'-0"

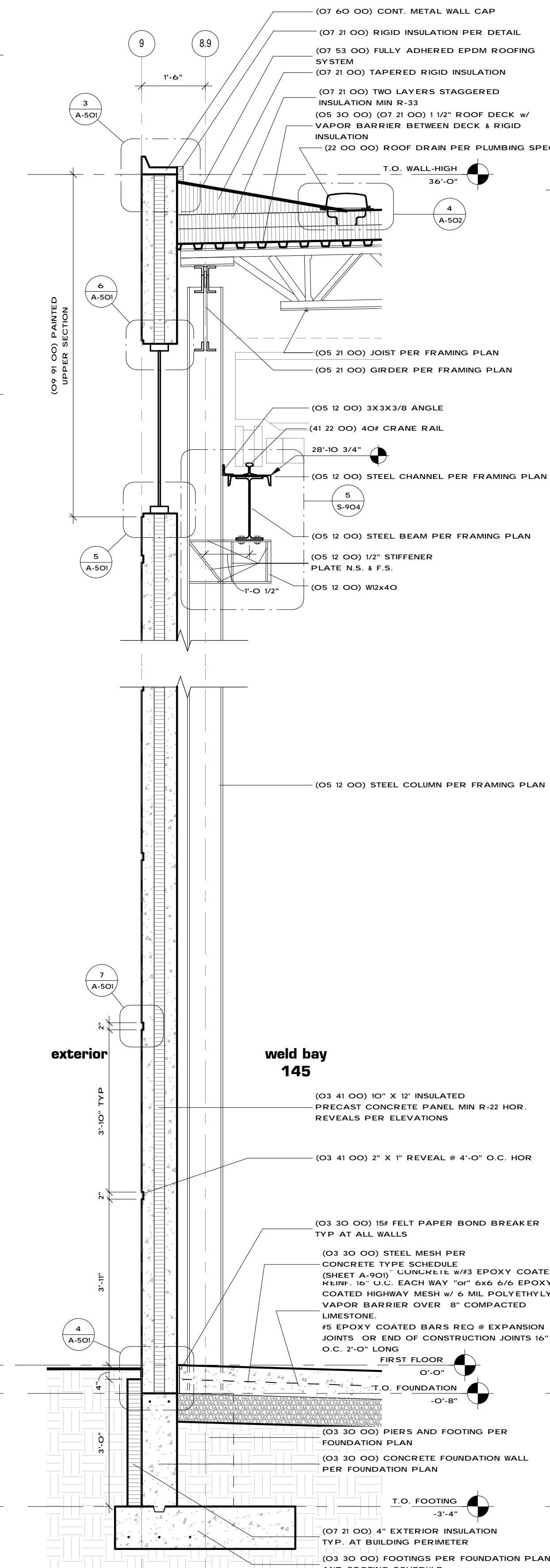

2 Wall Section
1/2" = 1'-0"

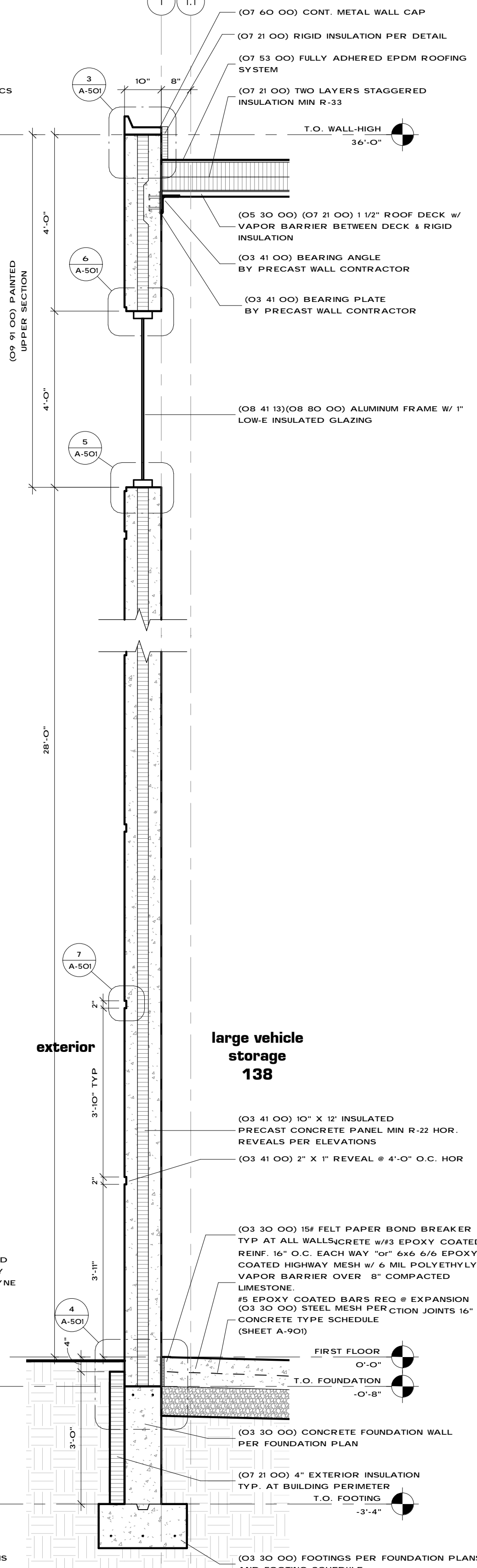

1 Wall Section
1/2" = 1'-0"

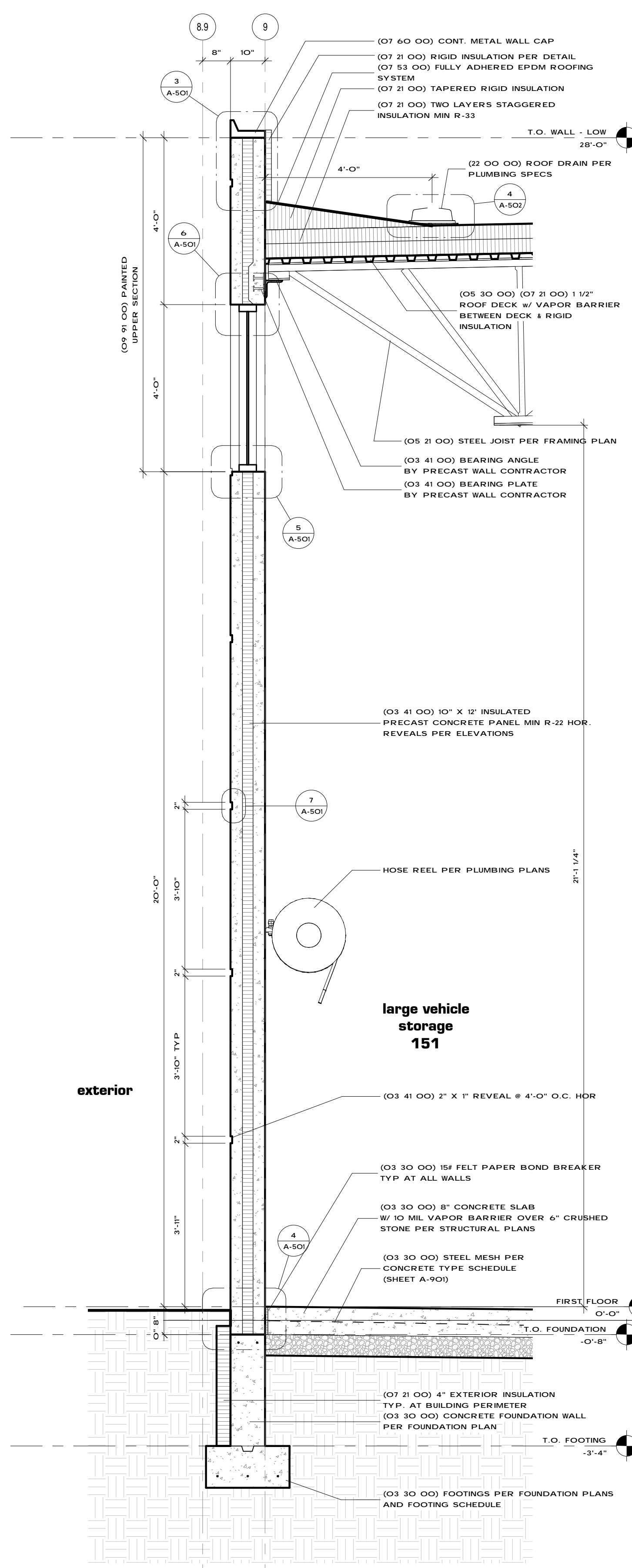

5 Wall Section
1/2" = 1'-0"

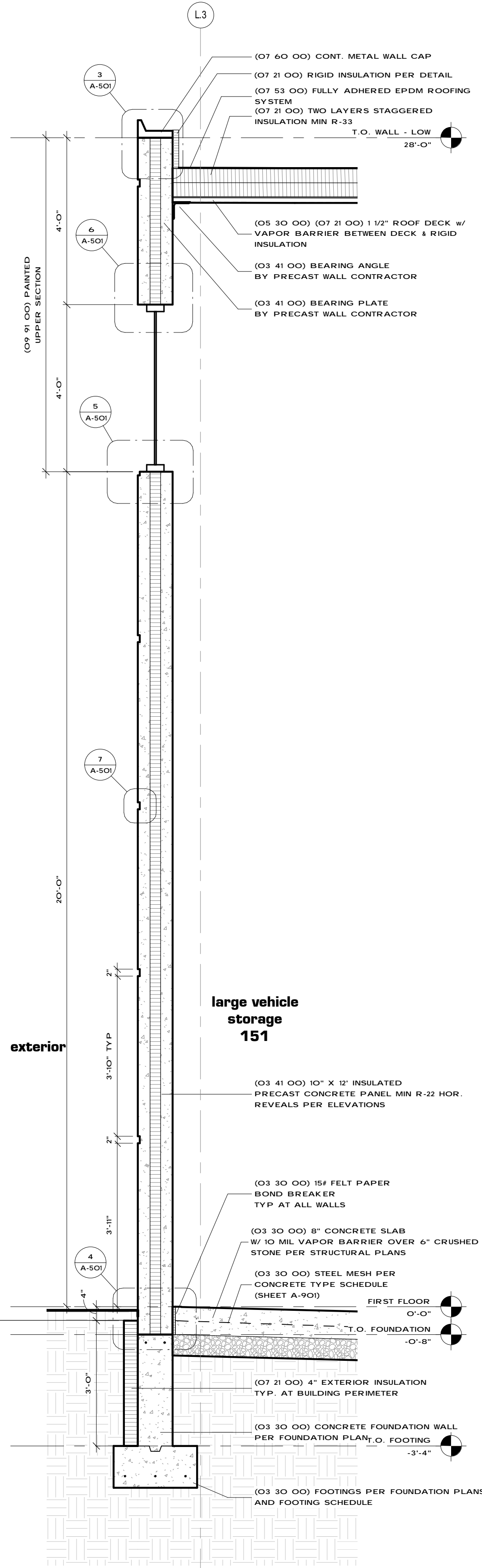

4 Wall Section
1/2" = 1'-0"

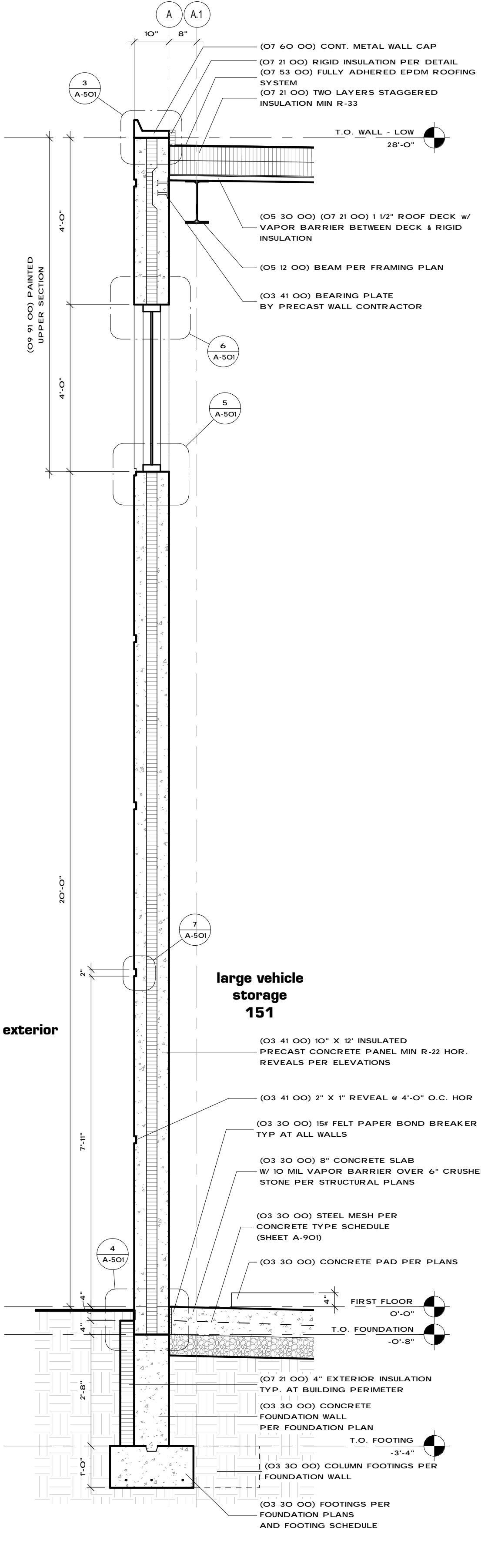

3 Wall Section
1/2" = 1'-0"

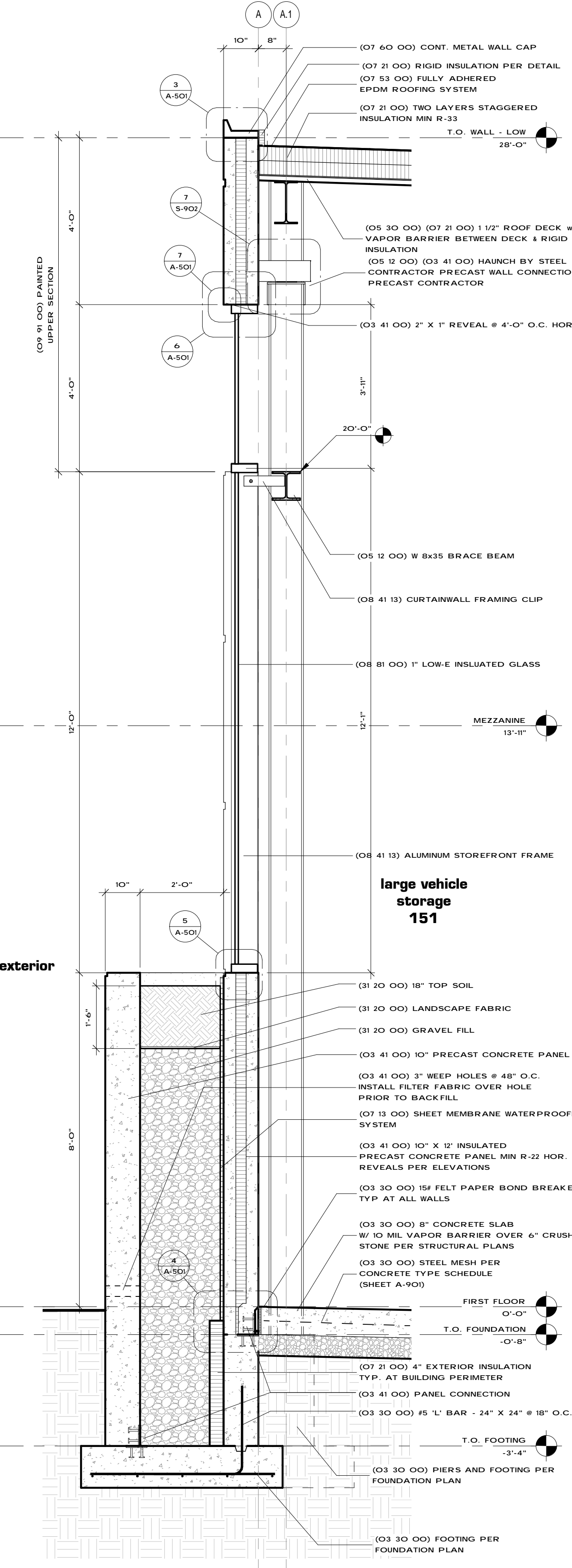

2 Wall Section
1/2" = 1'-0"

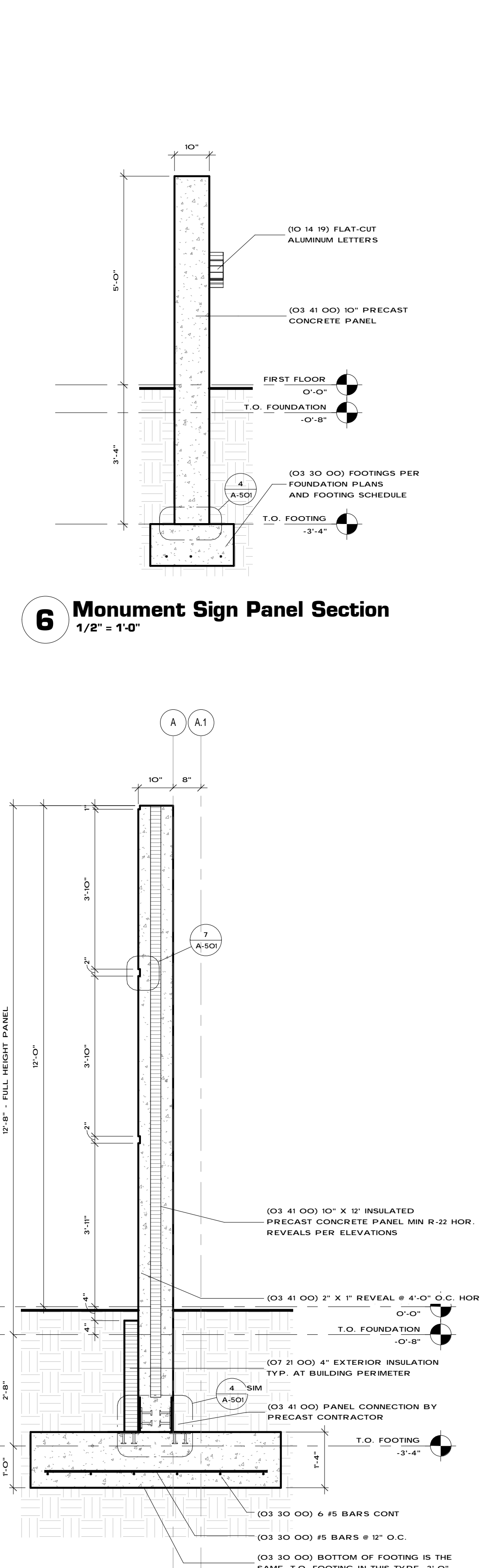

1 Wall Section
1/2" = 1'-0"

6 Monument Sign Panel Section
1/2" = 1'-0"

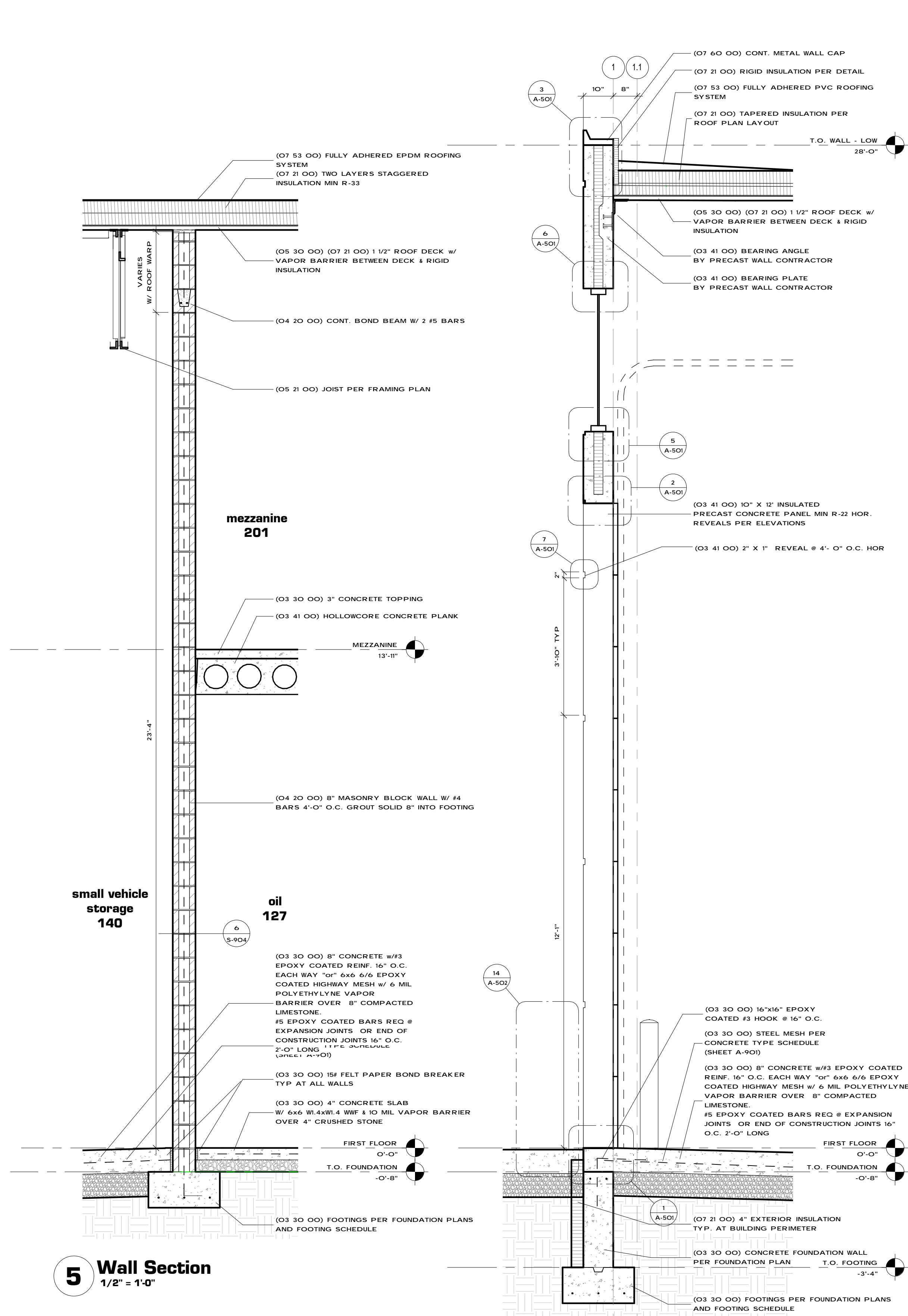

5 Wall Section
1/2" = 1'-0"

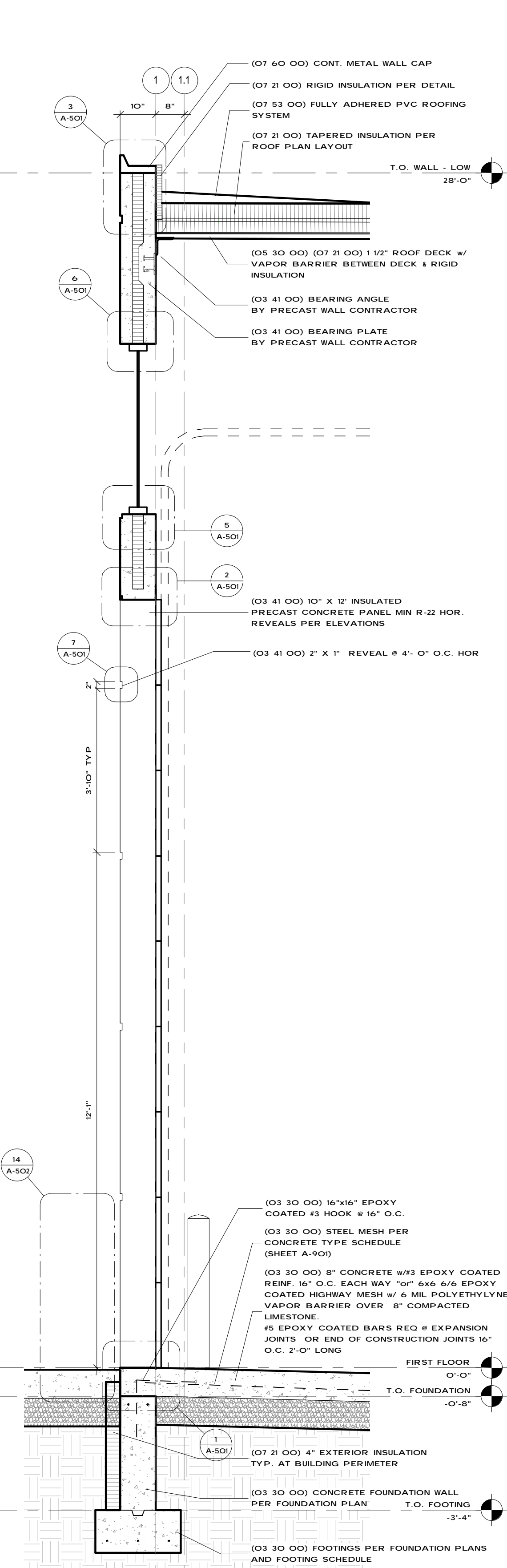

4 Wall Section
1/2" = 1'-0"

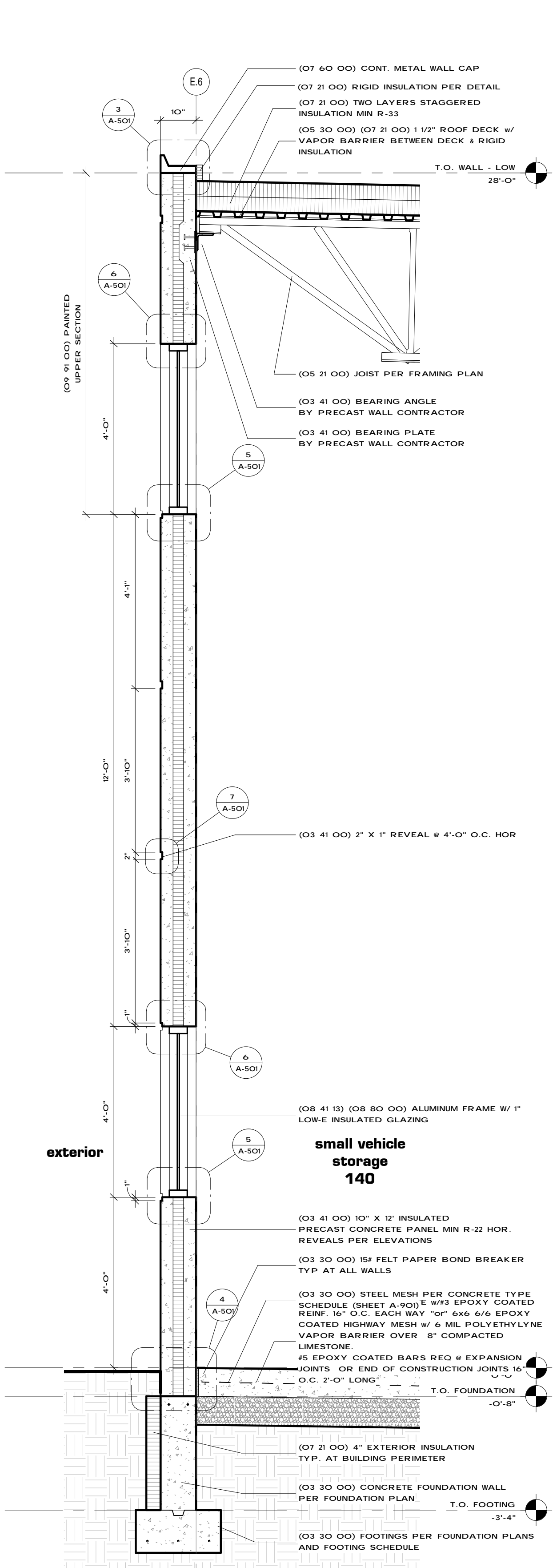

3 Wall Section
1/2" = 1'-0"

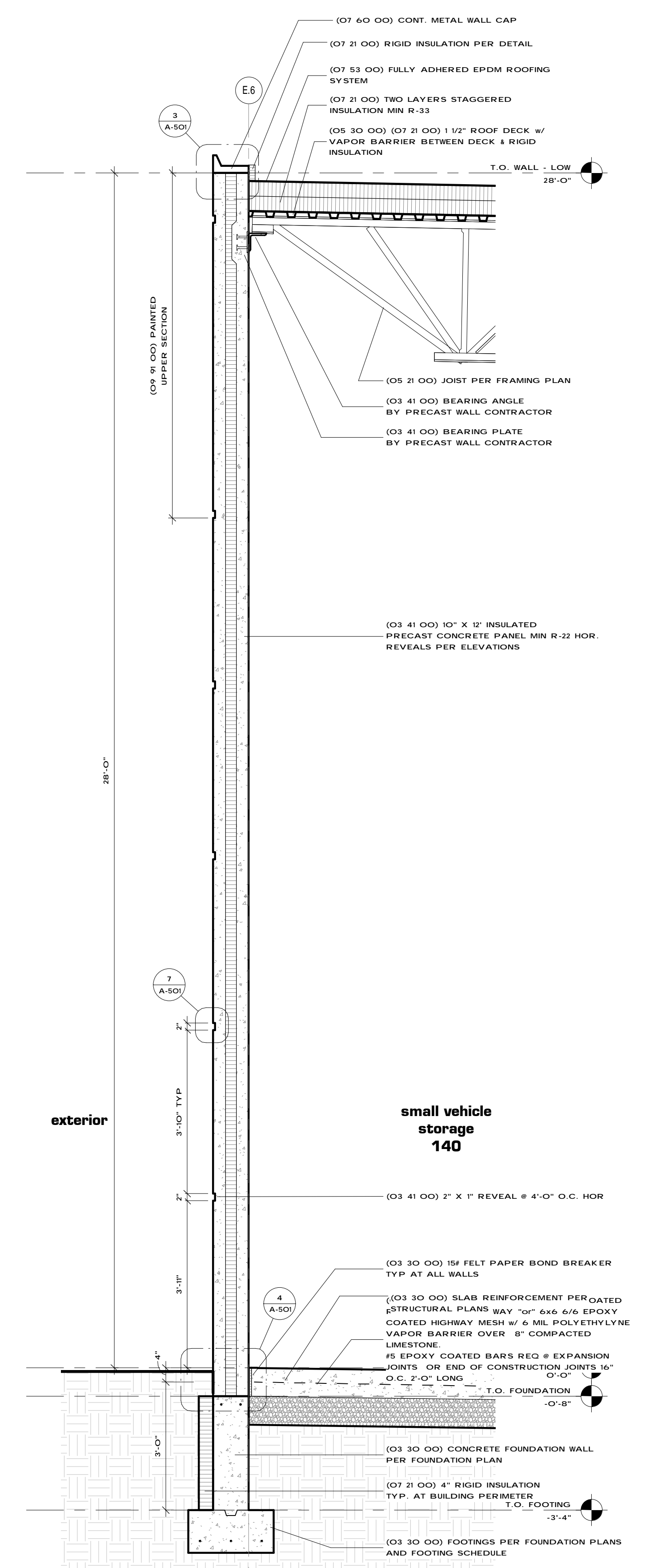

2 Wall Section
1/2" = 1'-0"

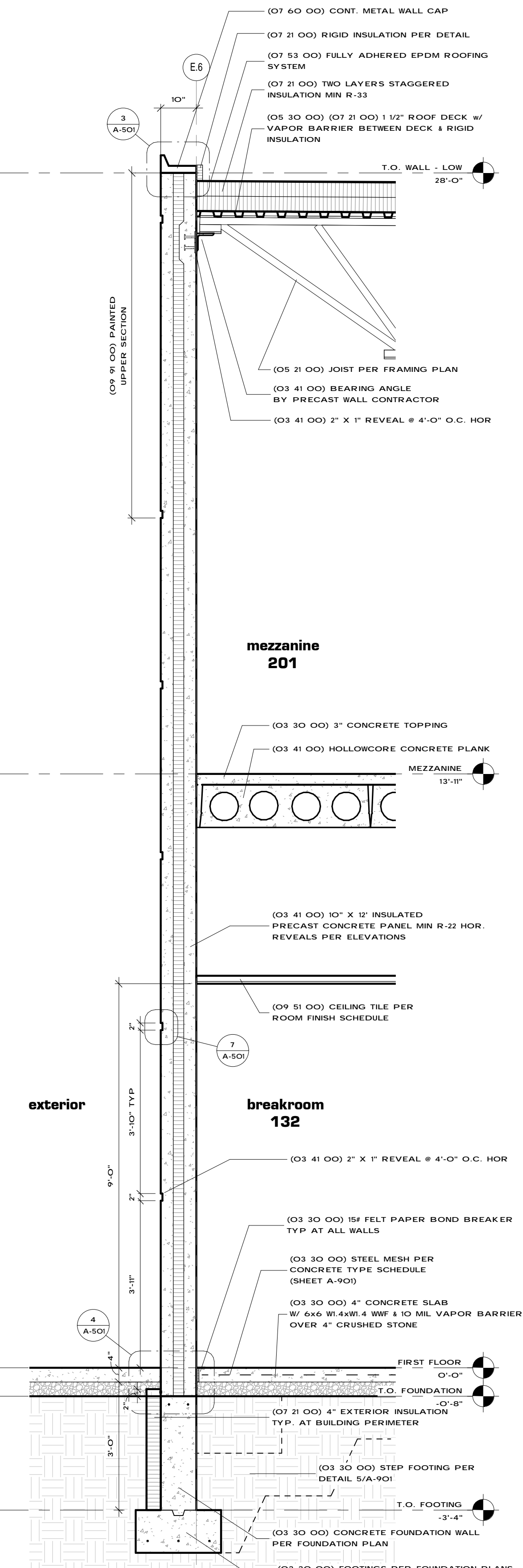

1 Wall Section
1/2" = 1'-0"

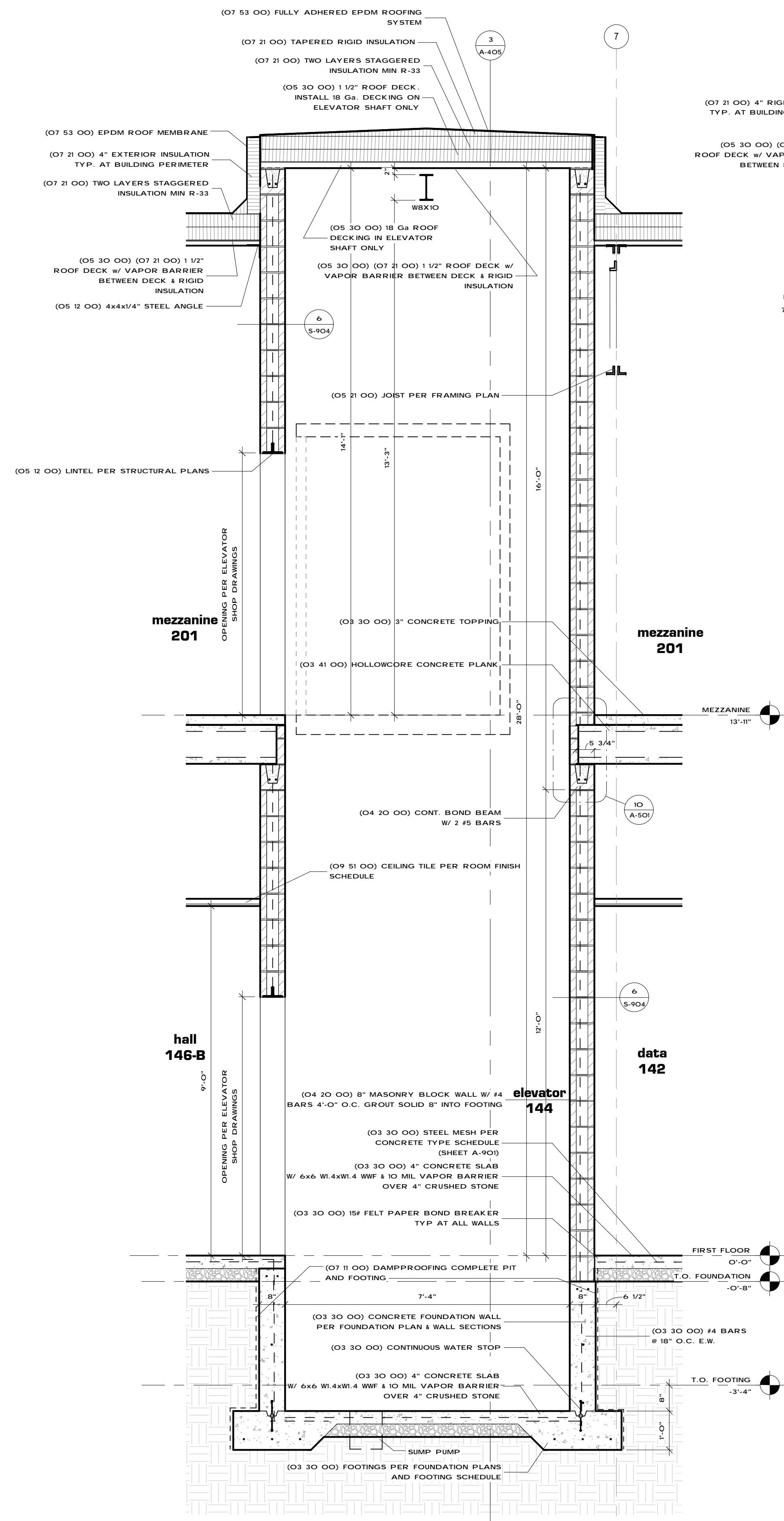

4 Wall Section
1/2" = 1'-0"

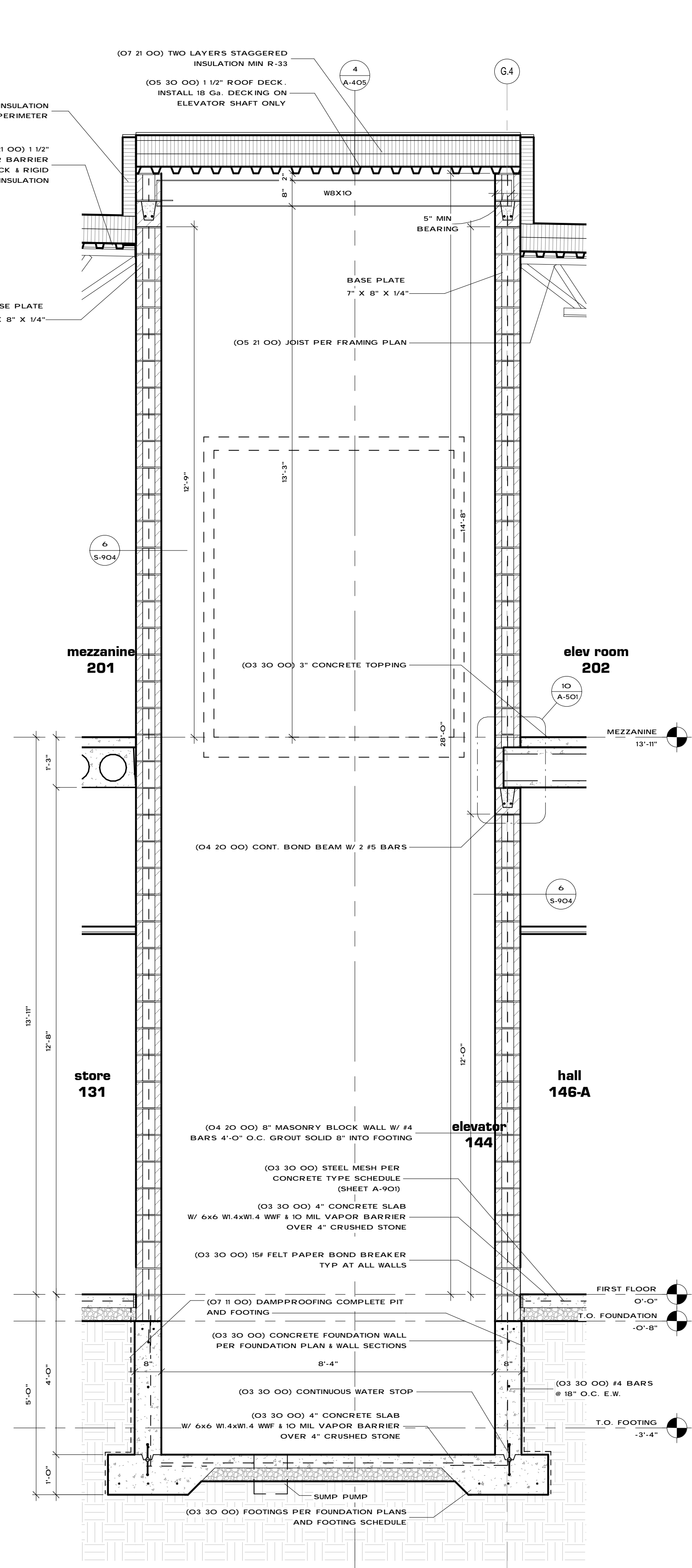

3 Wall Section
1/2" = 1'-0"

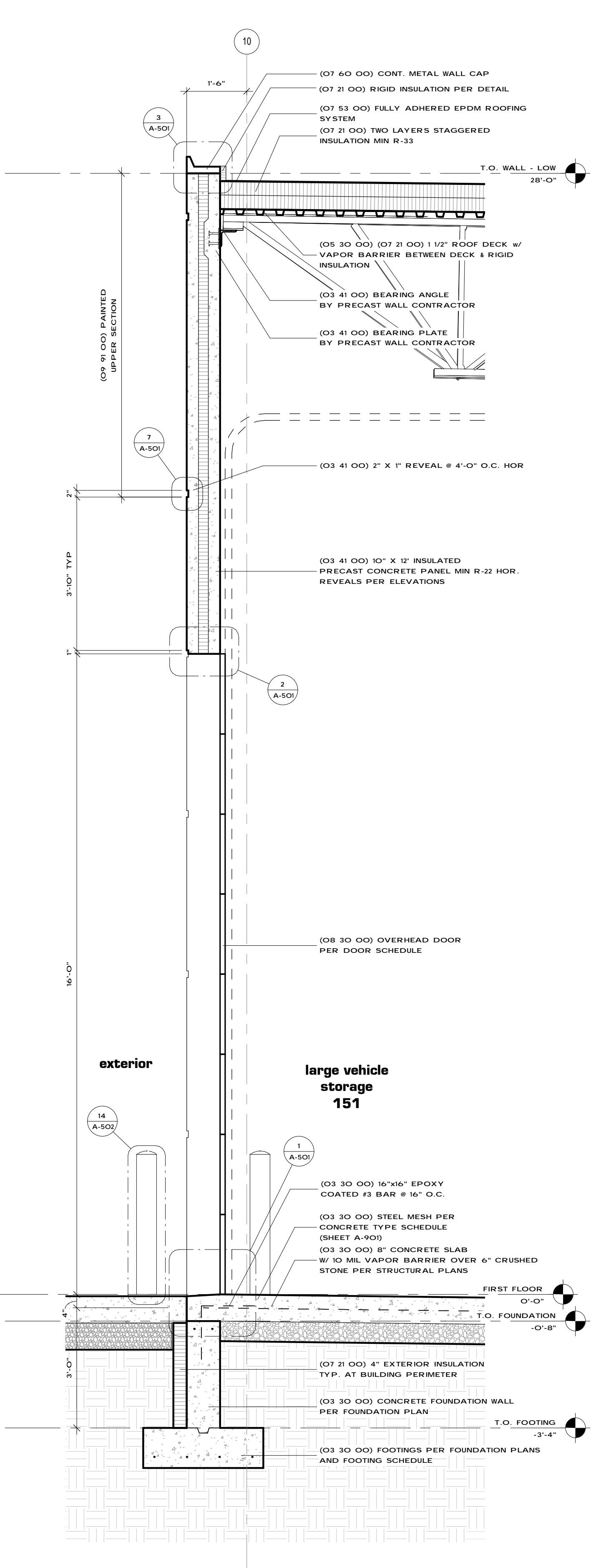

2 Wall Section
1/2" = 1'-0"

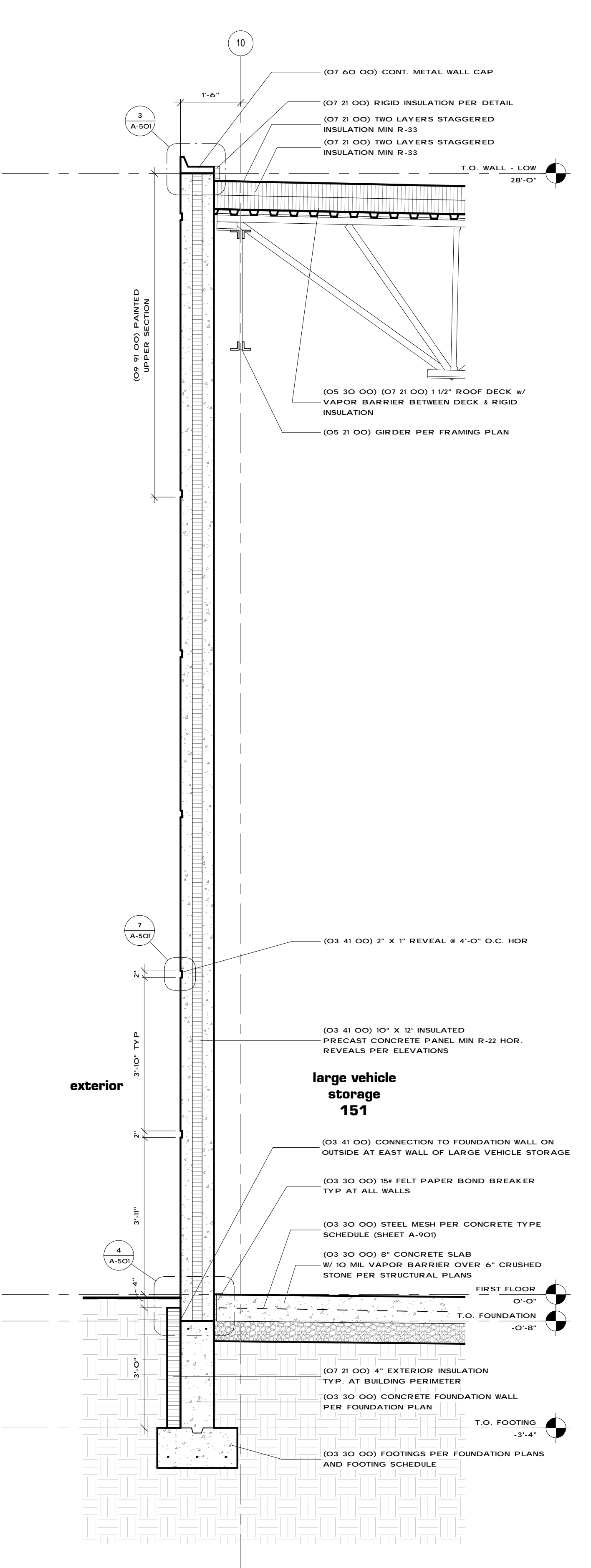

1 Wall Section
1/2" = 1'-0"

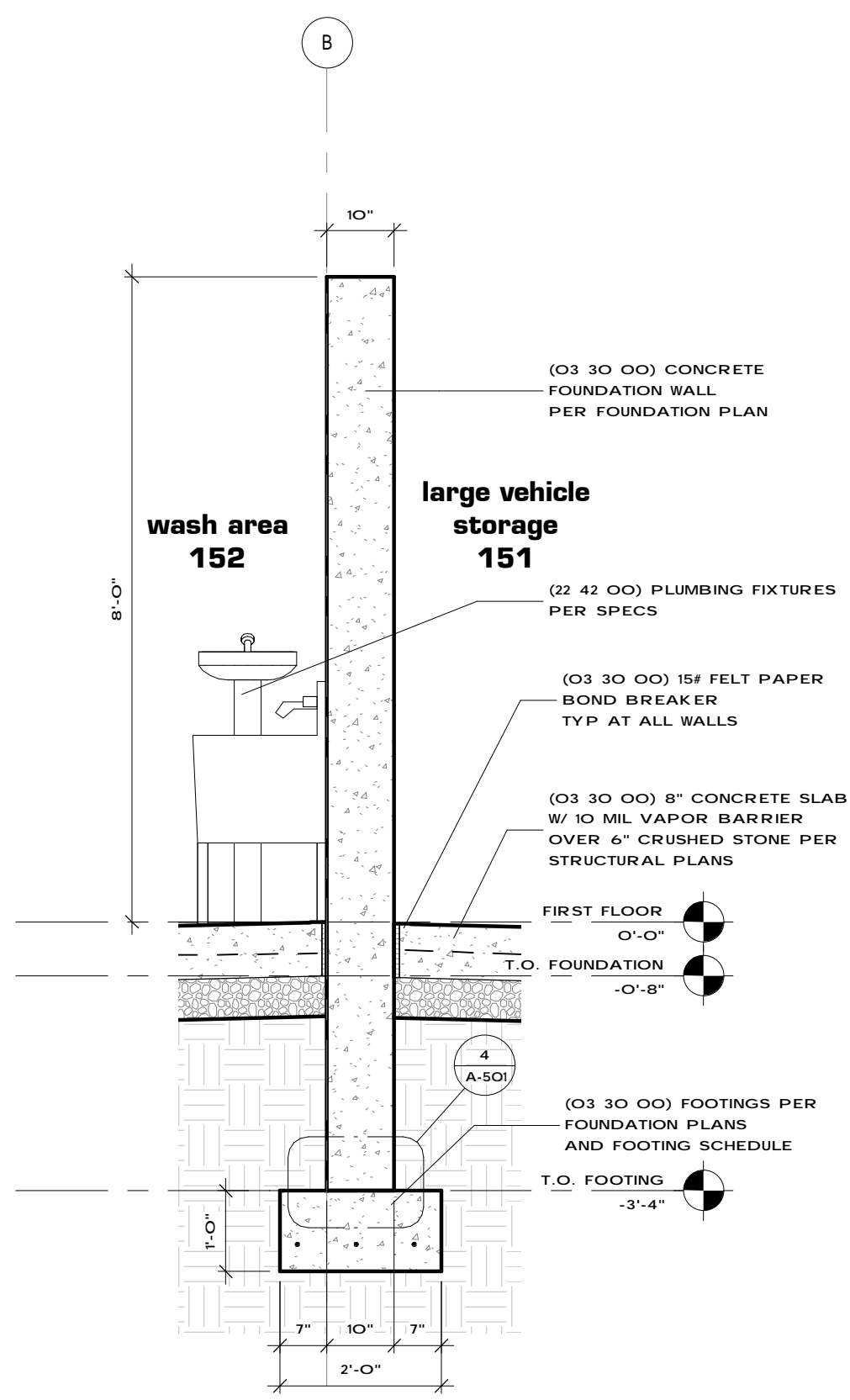

9 Screenwall @ Wash area
1/2" = 1'-0"

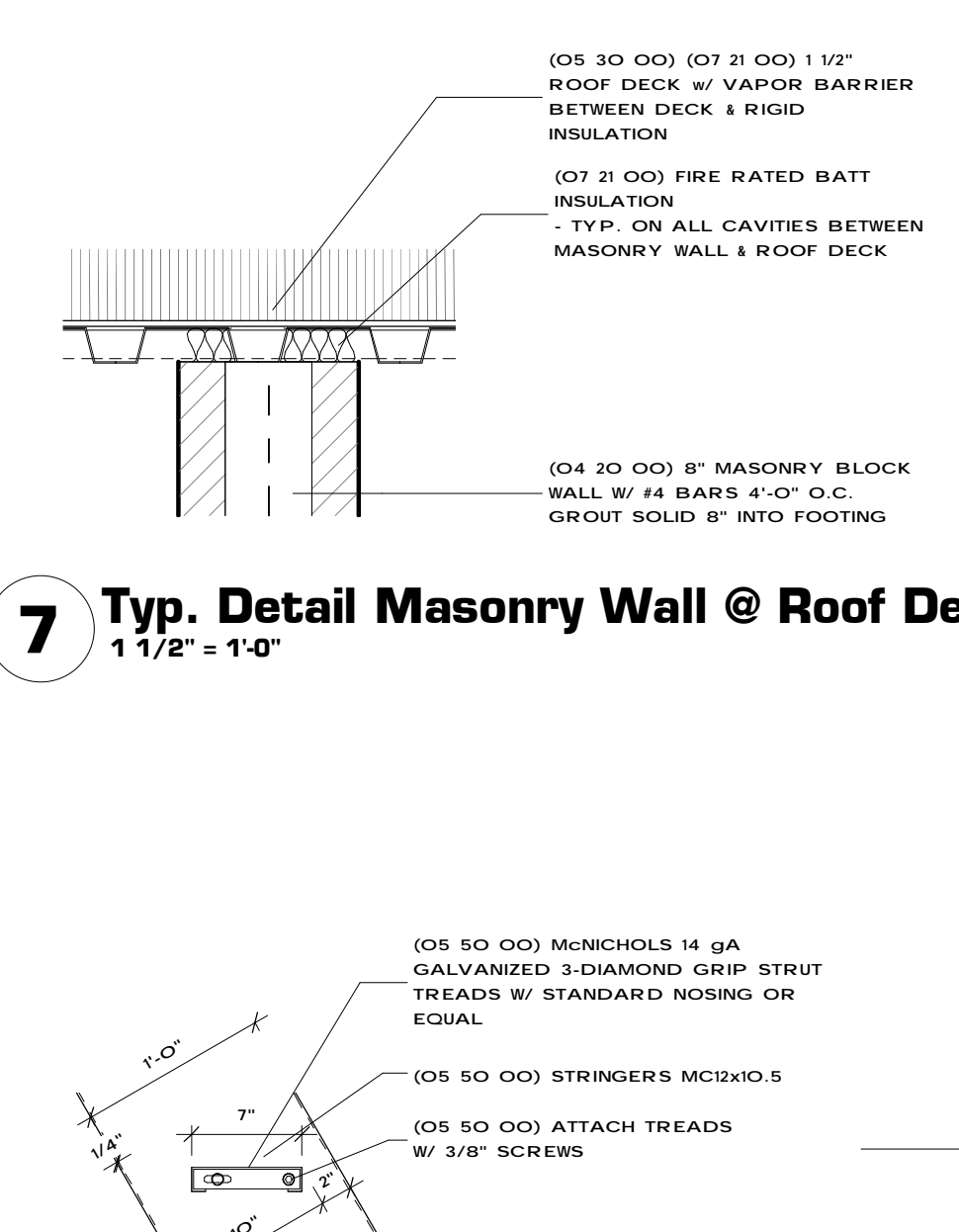

7 Typ. Detail Masonry Wall @ Roof Deck
1 1/2" = 1'-0"

8 Tread Detail
1" = 1'-0"

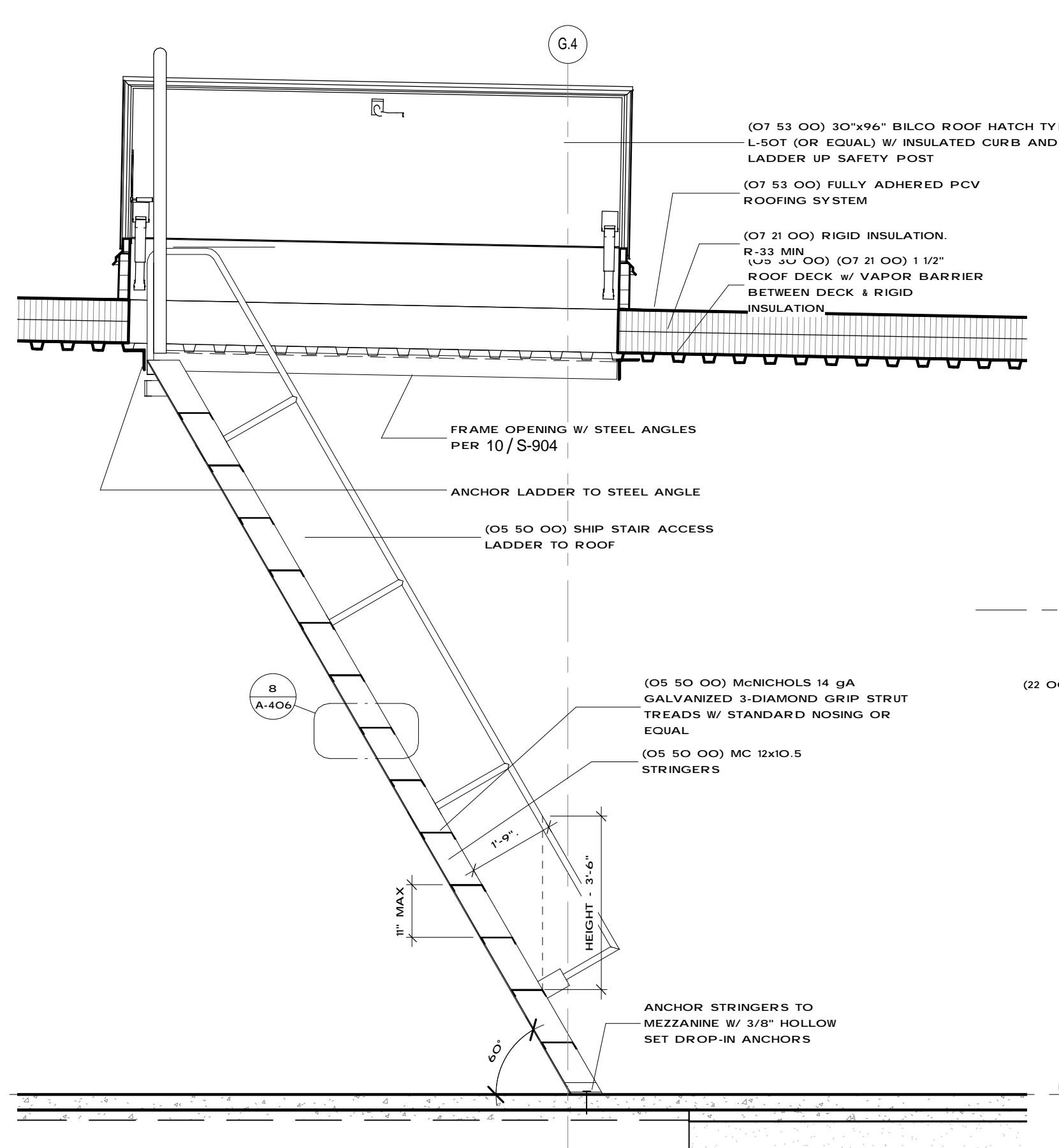

6 Roof Access Ladder
1/2" = 1'-0"

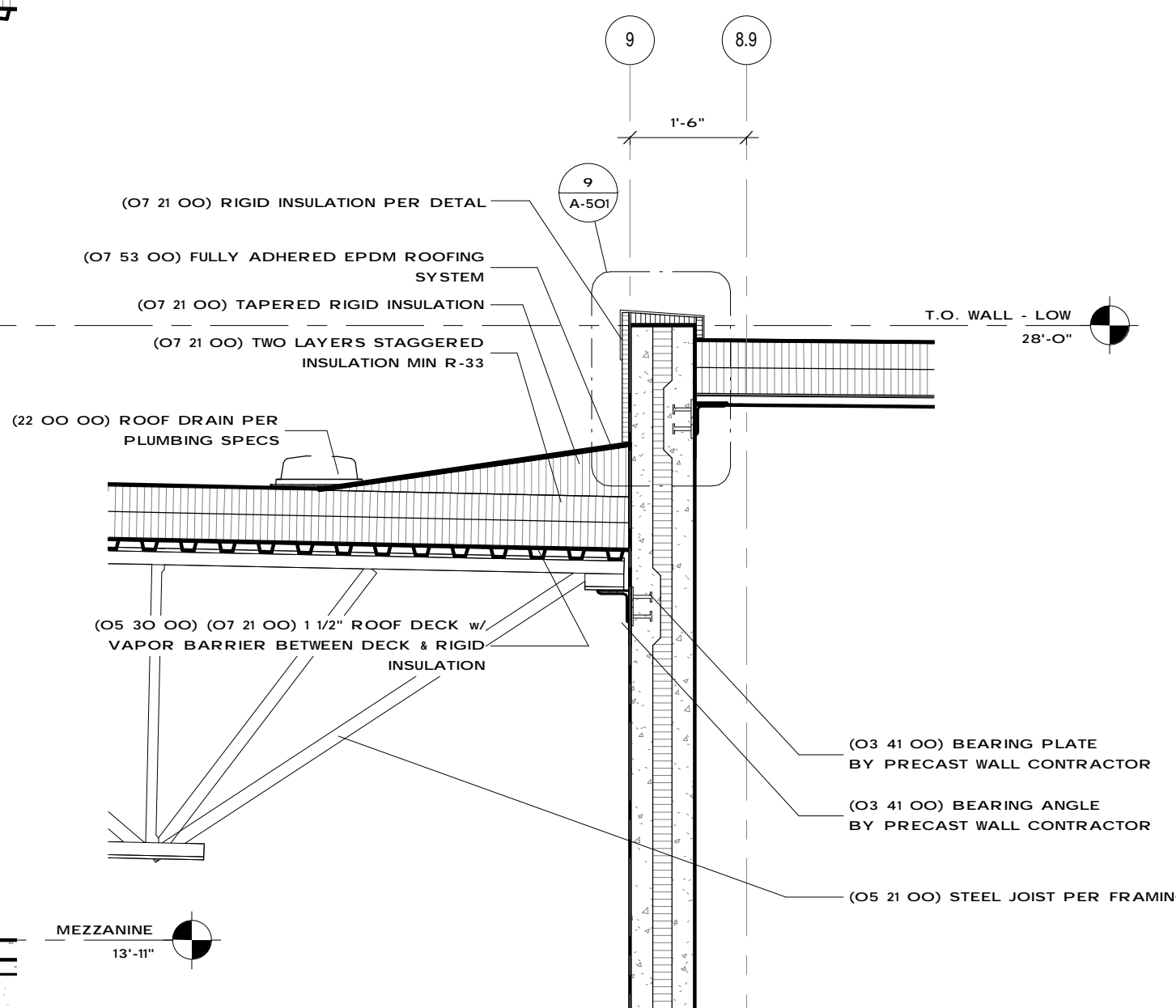

2 Wall Section
1/2" = 1'-0"

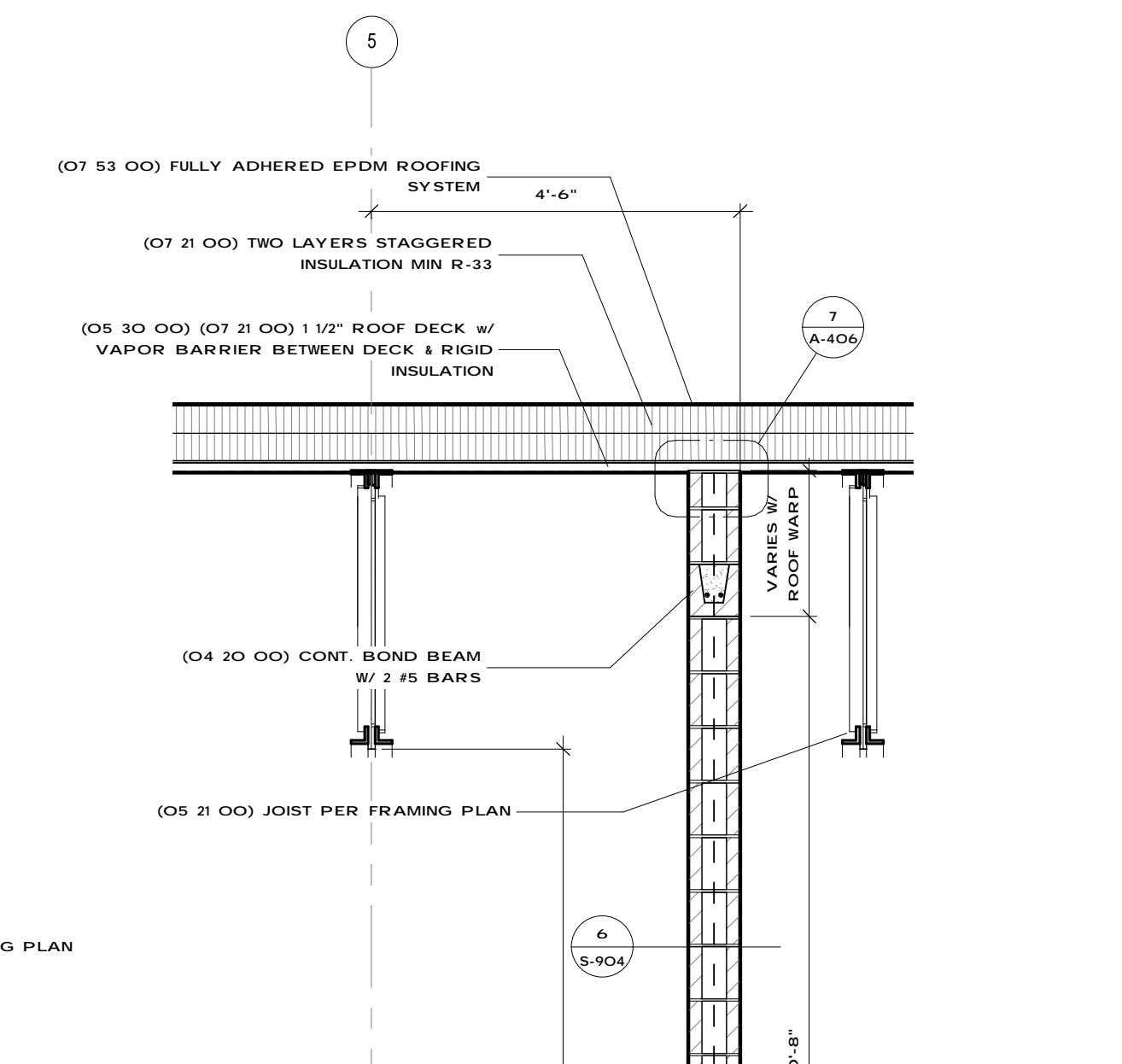

1 Wall Section
1/2" = 1'-0"

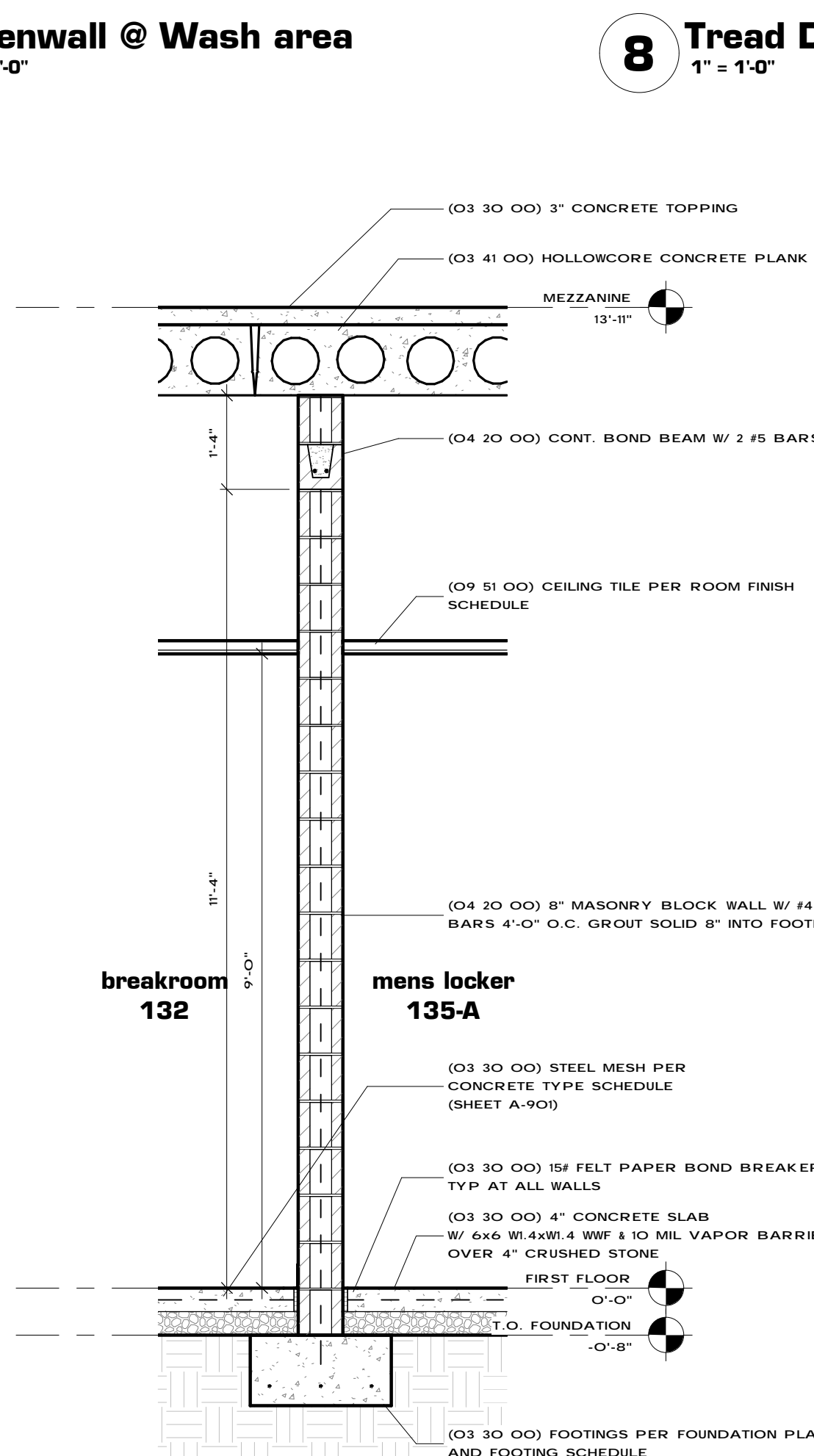

4 Wall Section - Non-bearing Wall
1/2" = 1'-0"

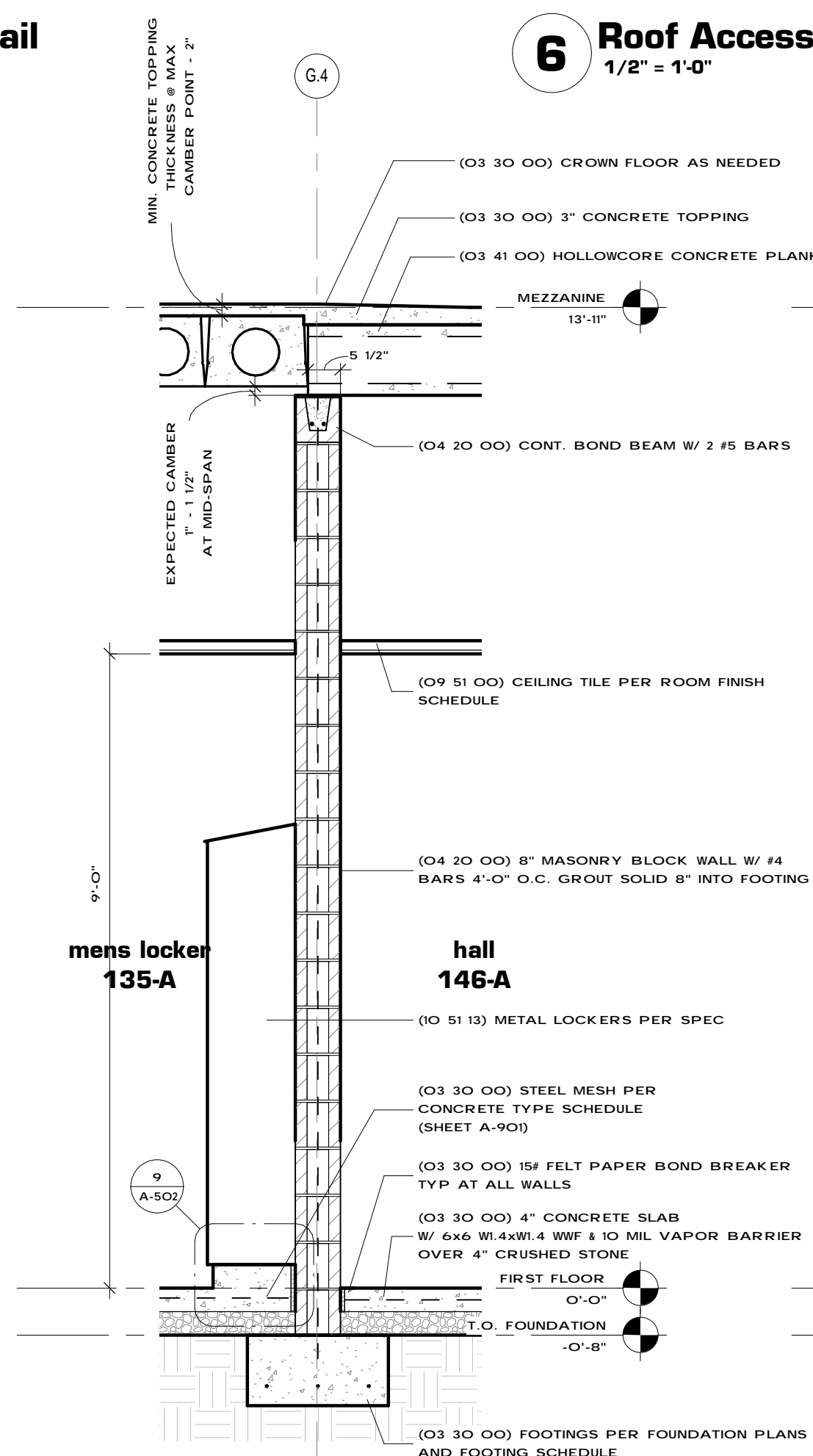

5 Wall Section - Bearing Wall
1/2" = 1'-0"

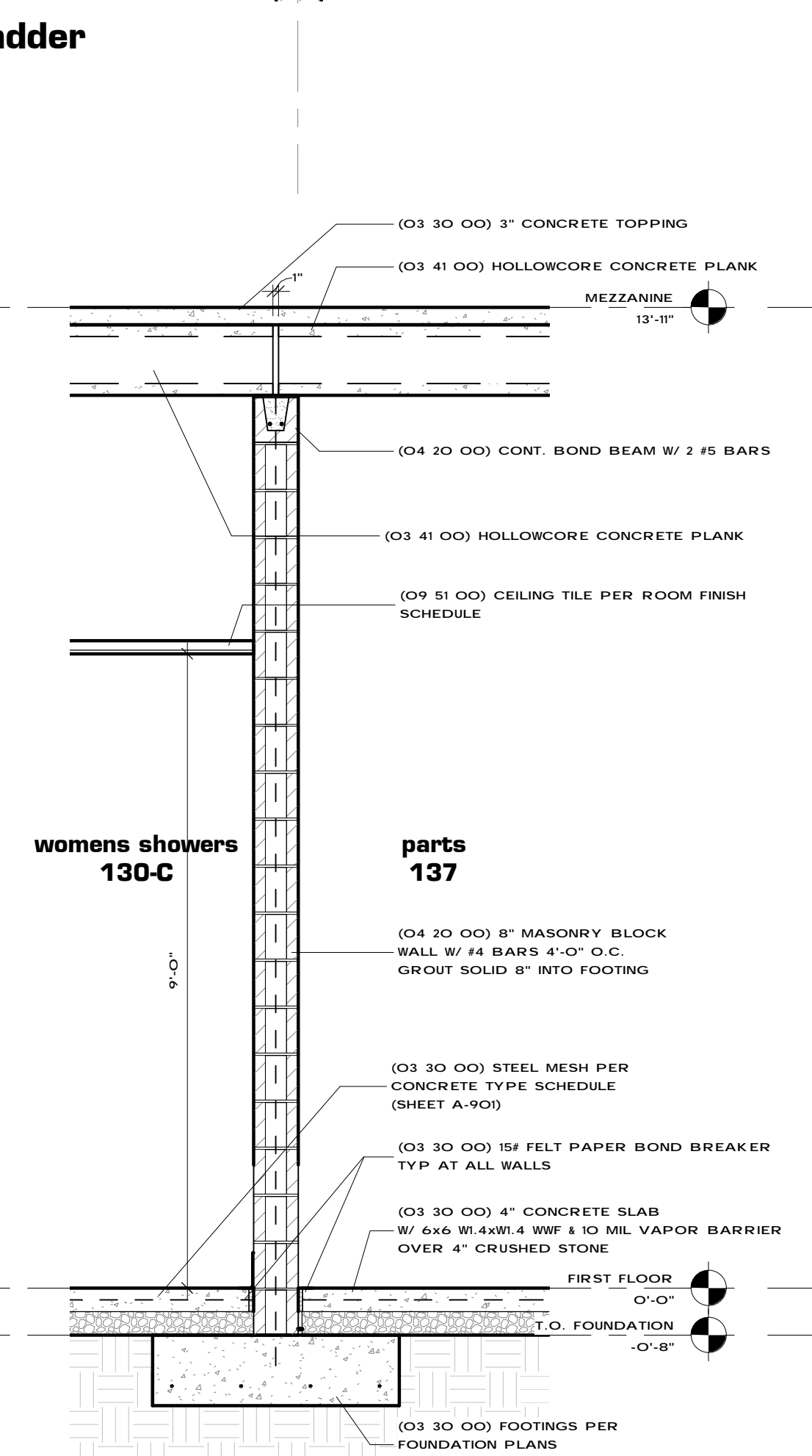

3 Wall Section - Bearing Wall
1/2" = 1'-0"

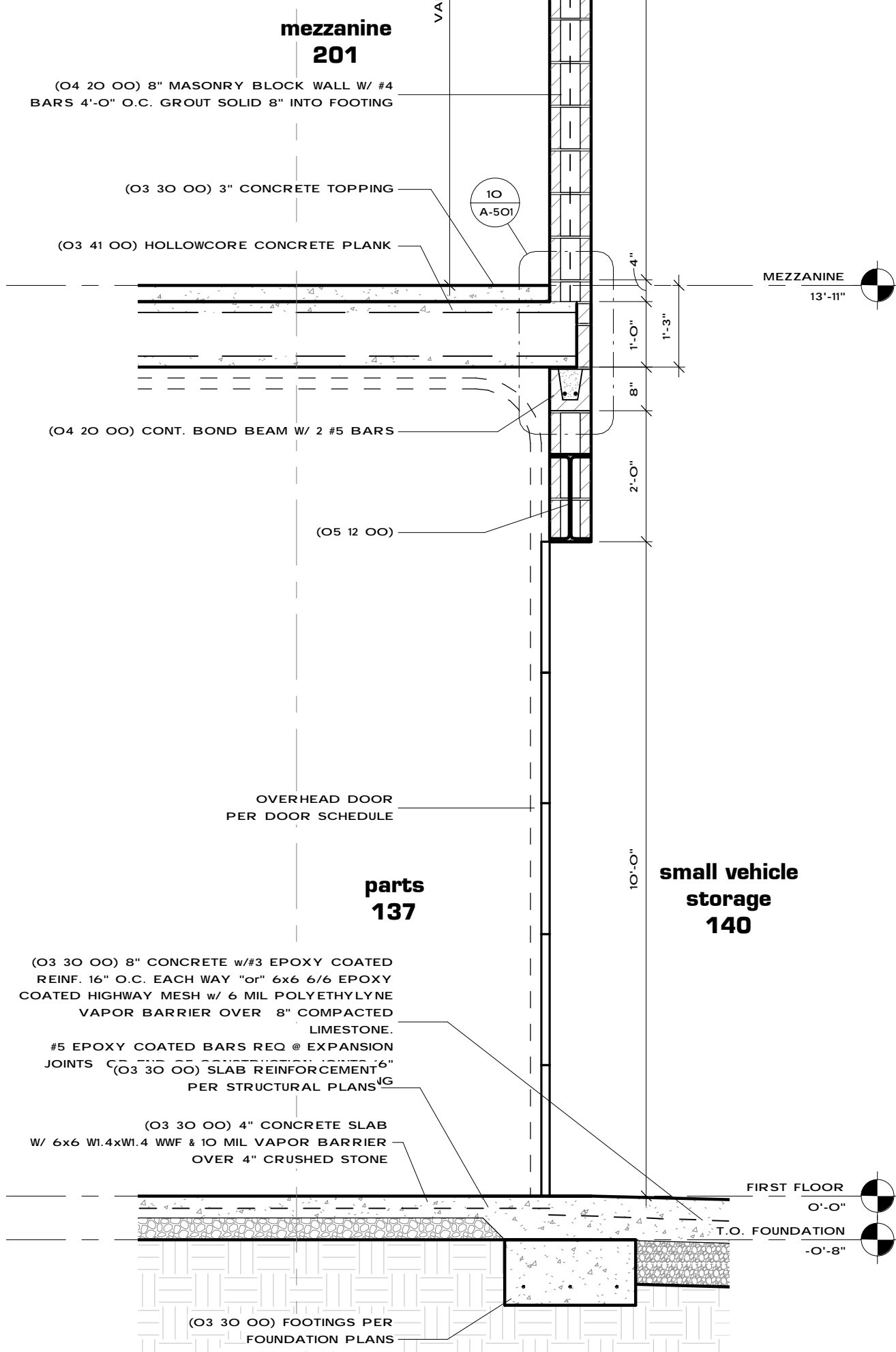
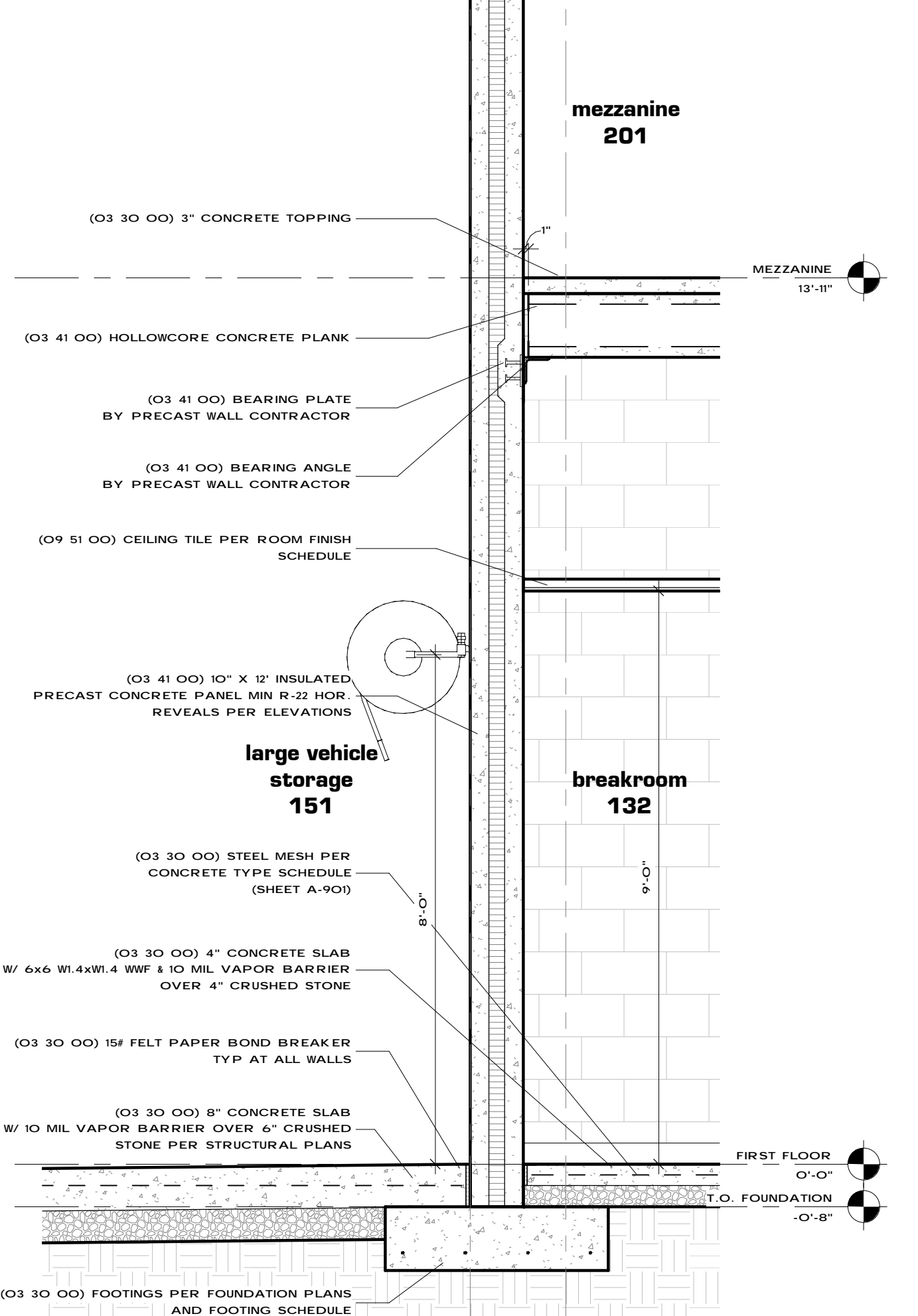

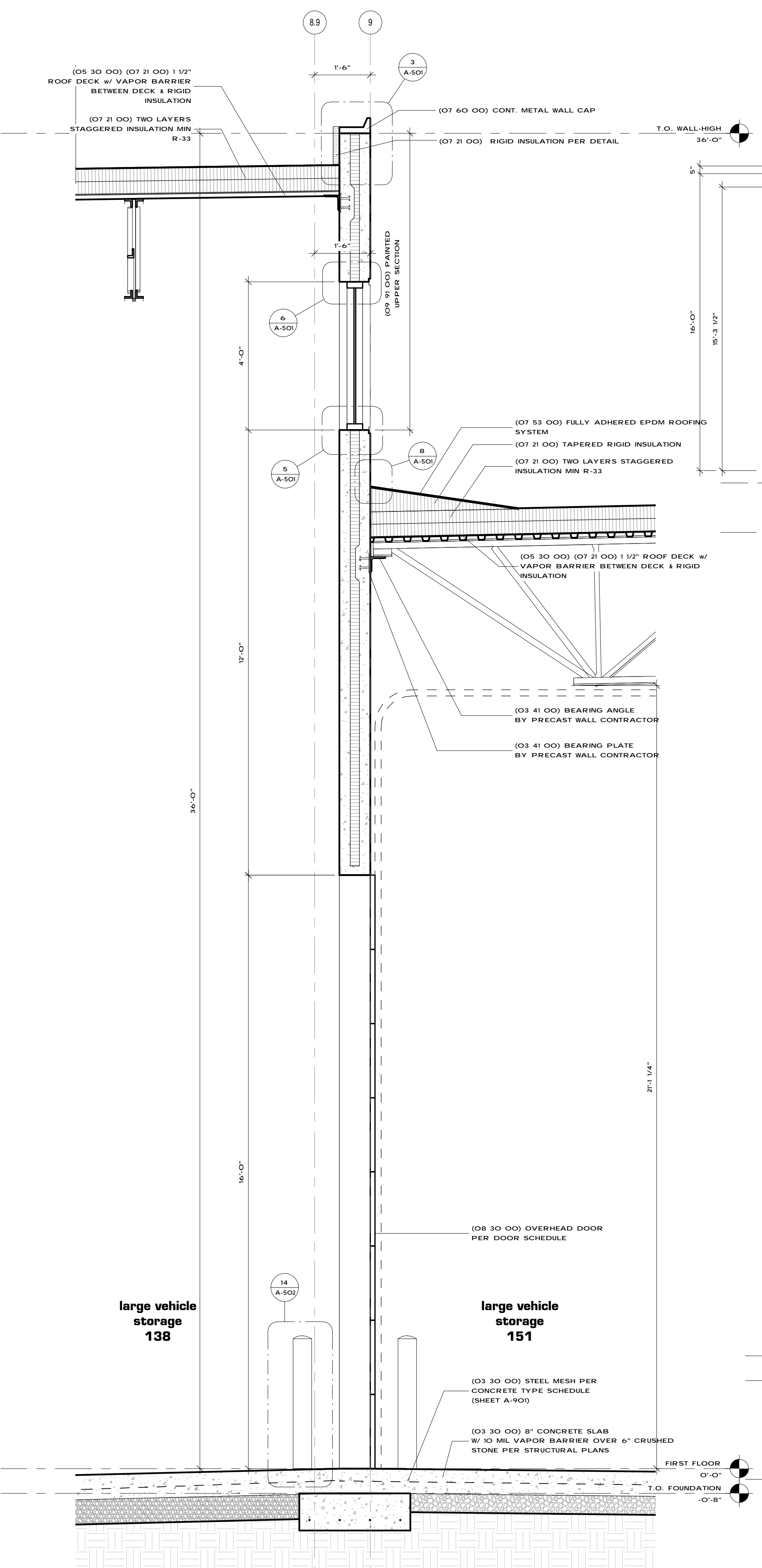

3 Wall Section
1/2" = 1'-0"

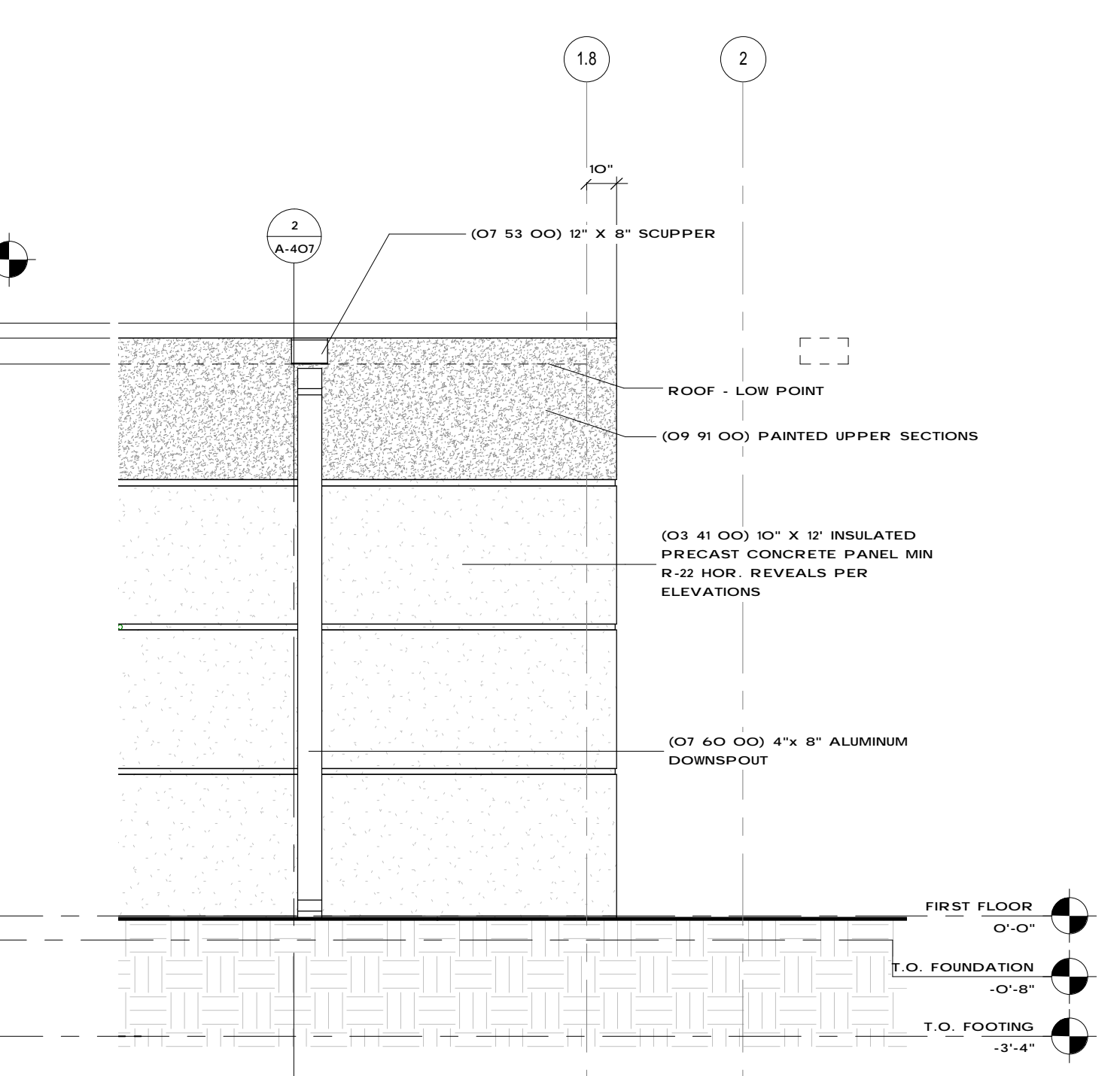

4 Fire Pump 156 - South Elevation
1/4" = 1'-0"

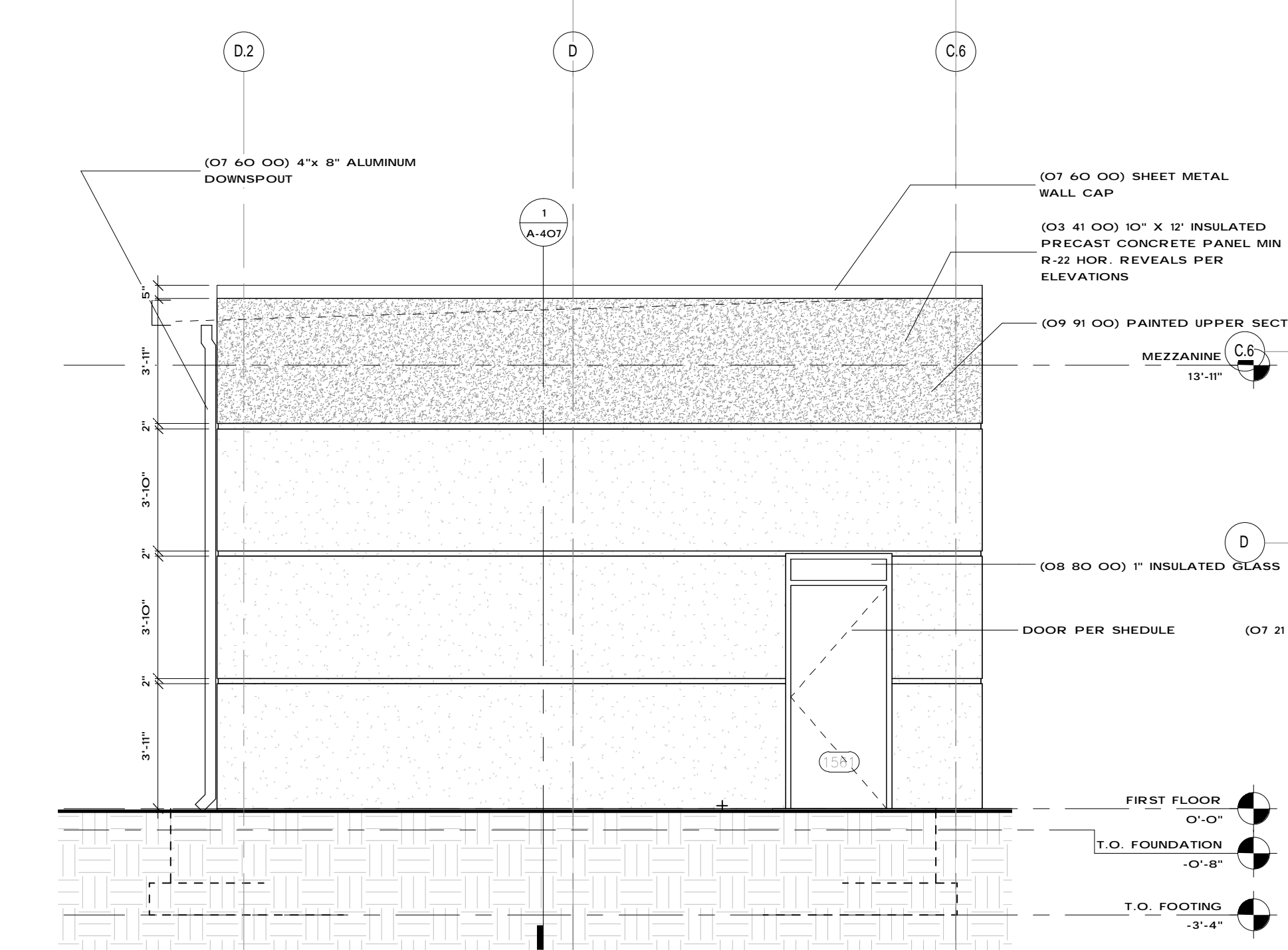

5 Fire Pump - East Elevation
1/4" = 1'-0"

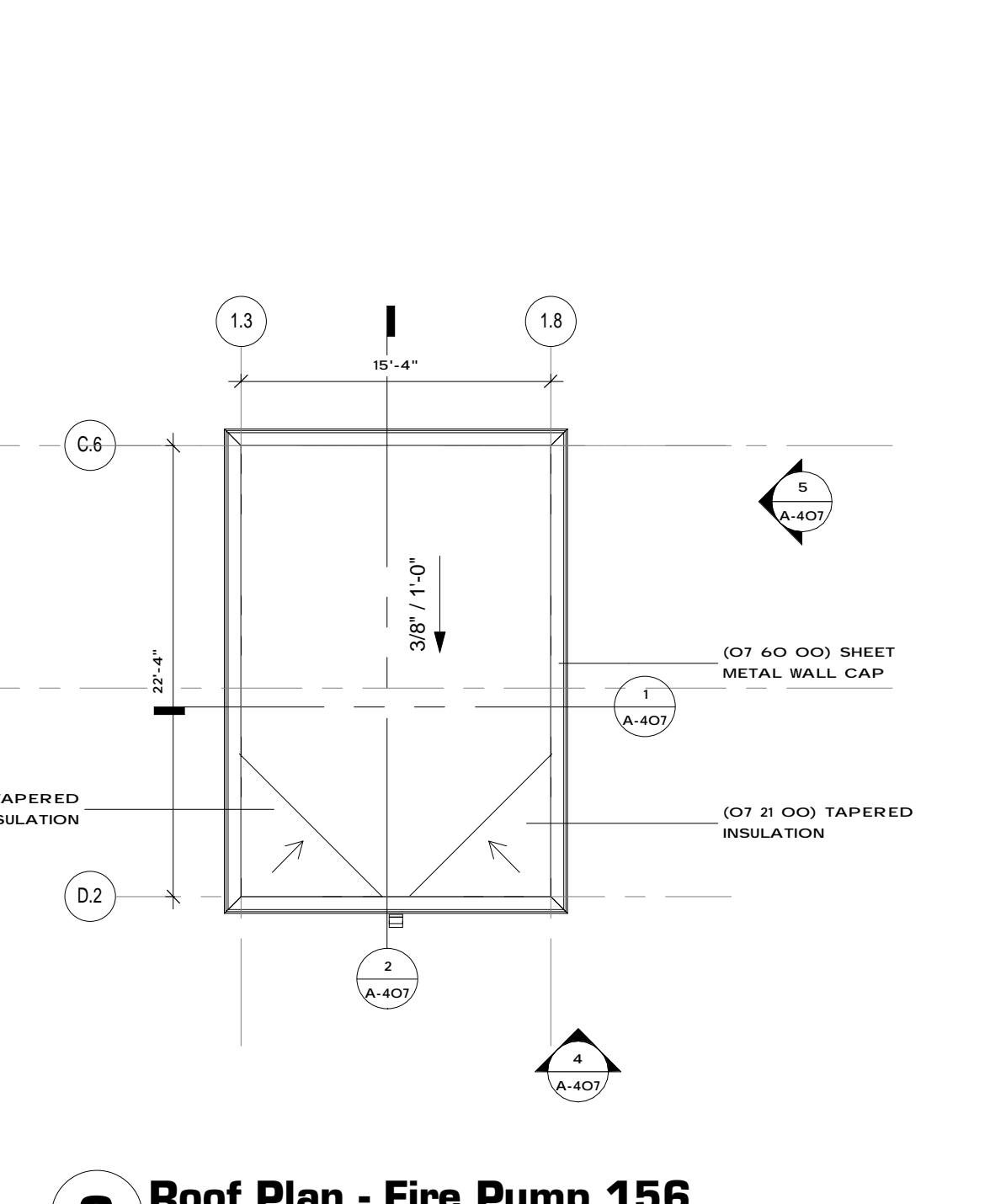

6 Roof Plan - Fire Pump 156
1/8" = 1'-0"

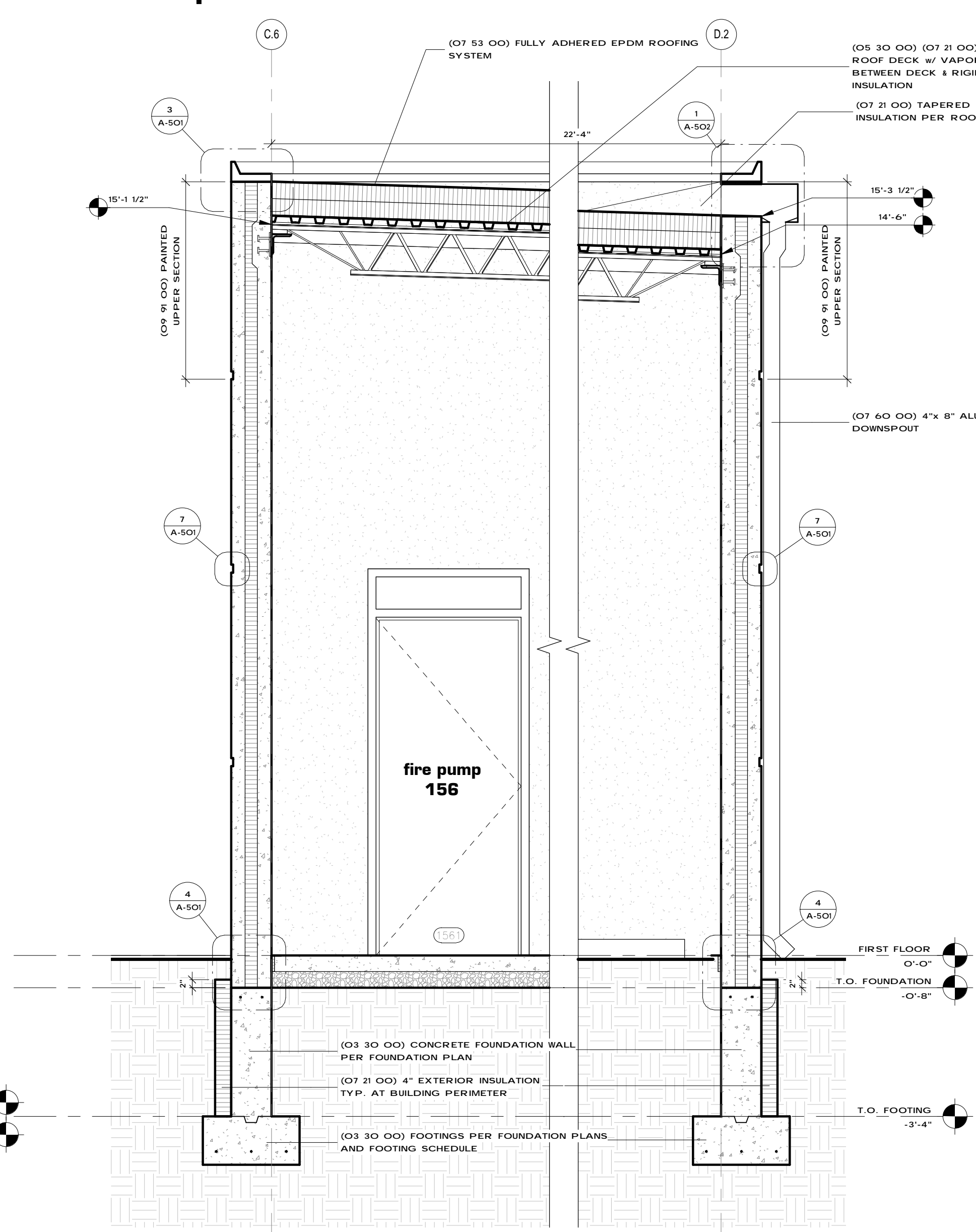

2 Wall Section
1/2" = 1'-0"

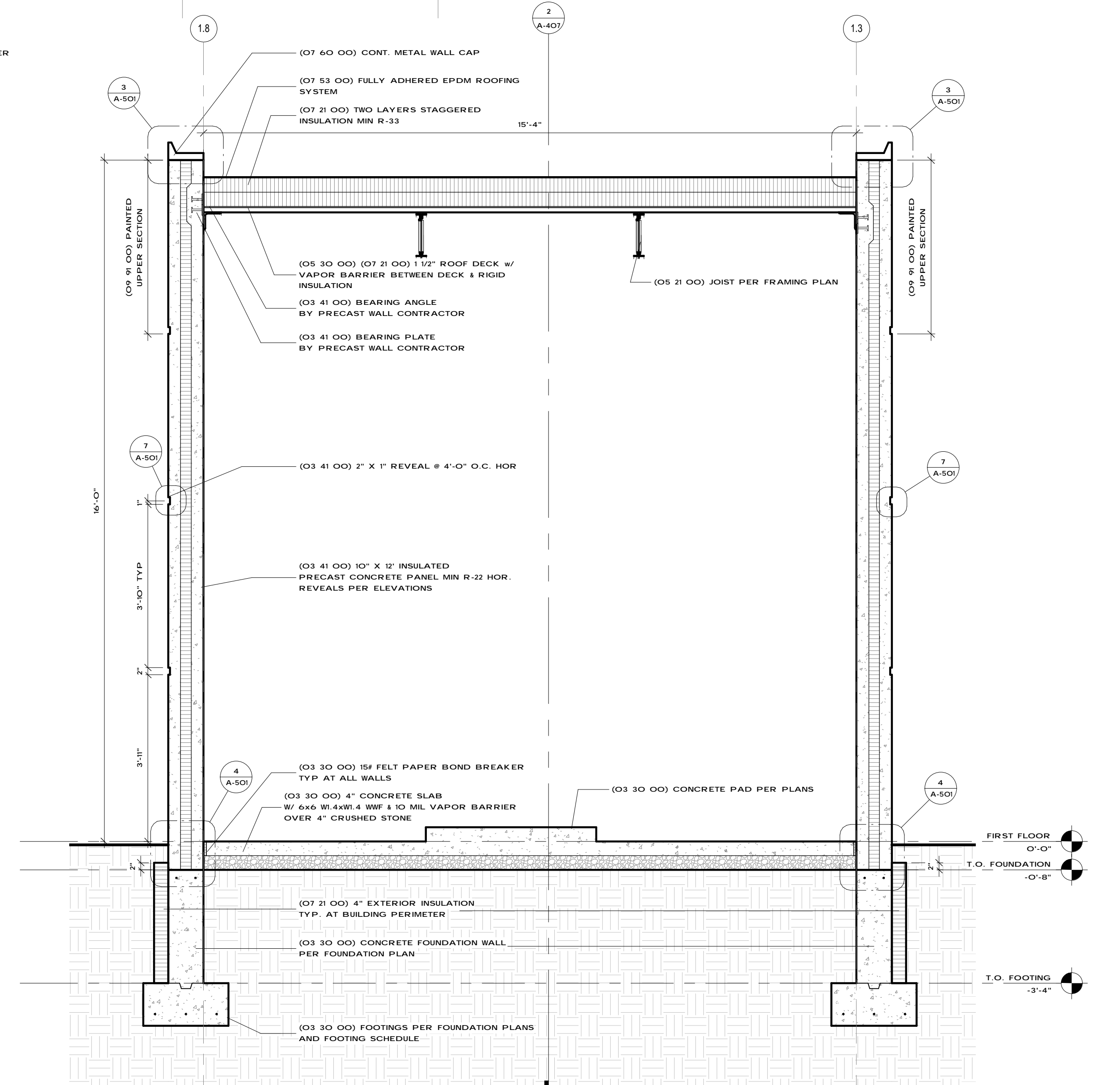

1 Wall Section
1/2" = 1'-0"

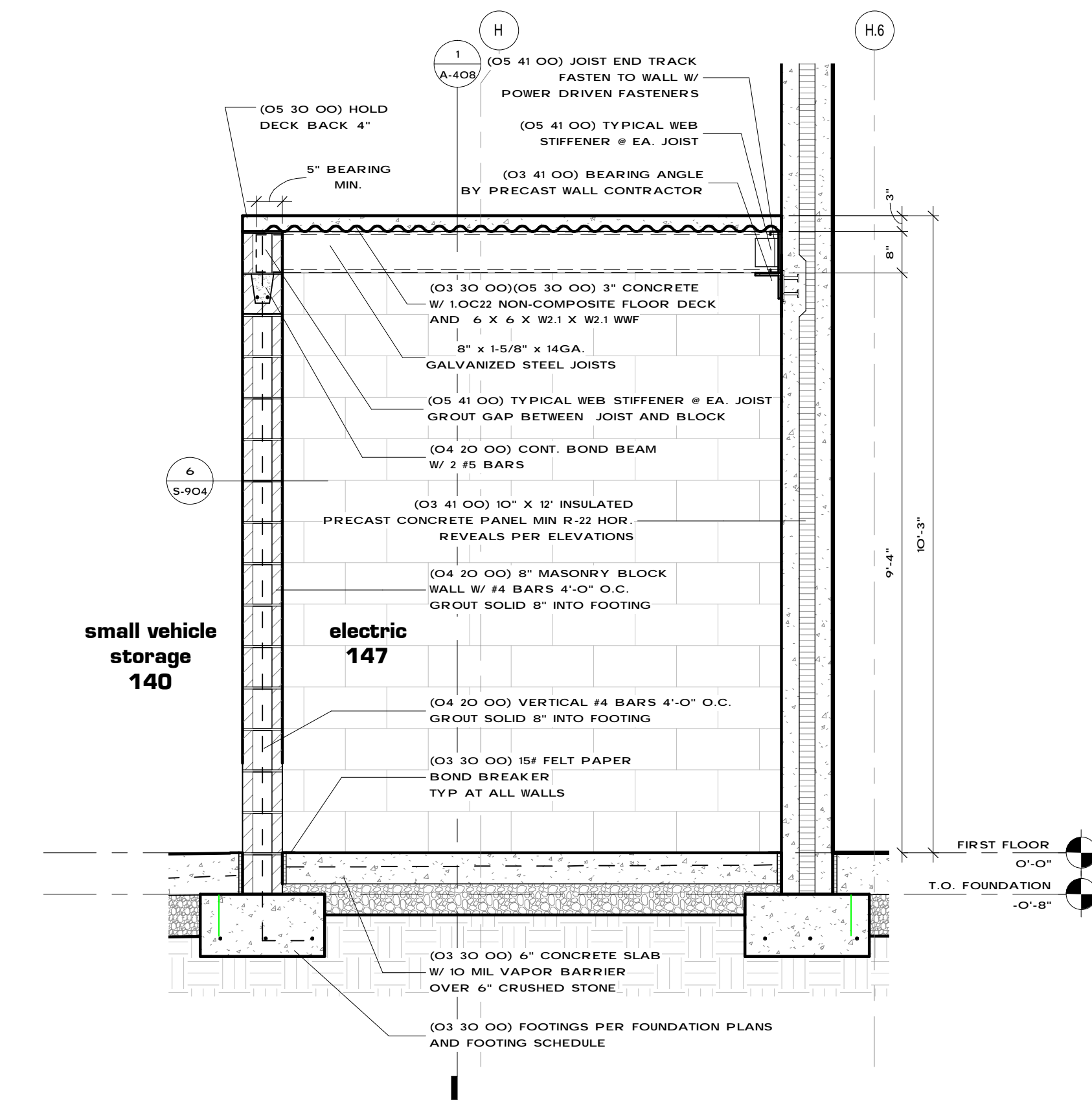

2 Section @ Electric Room 147
1/2" = 1'-0"

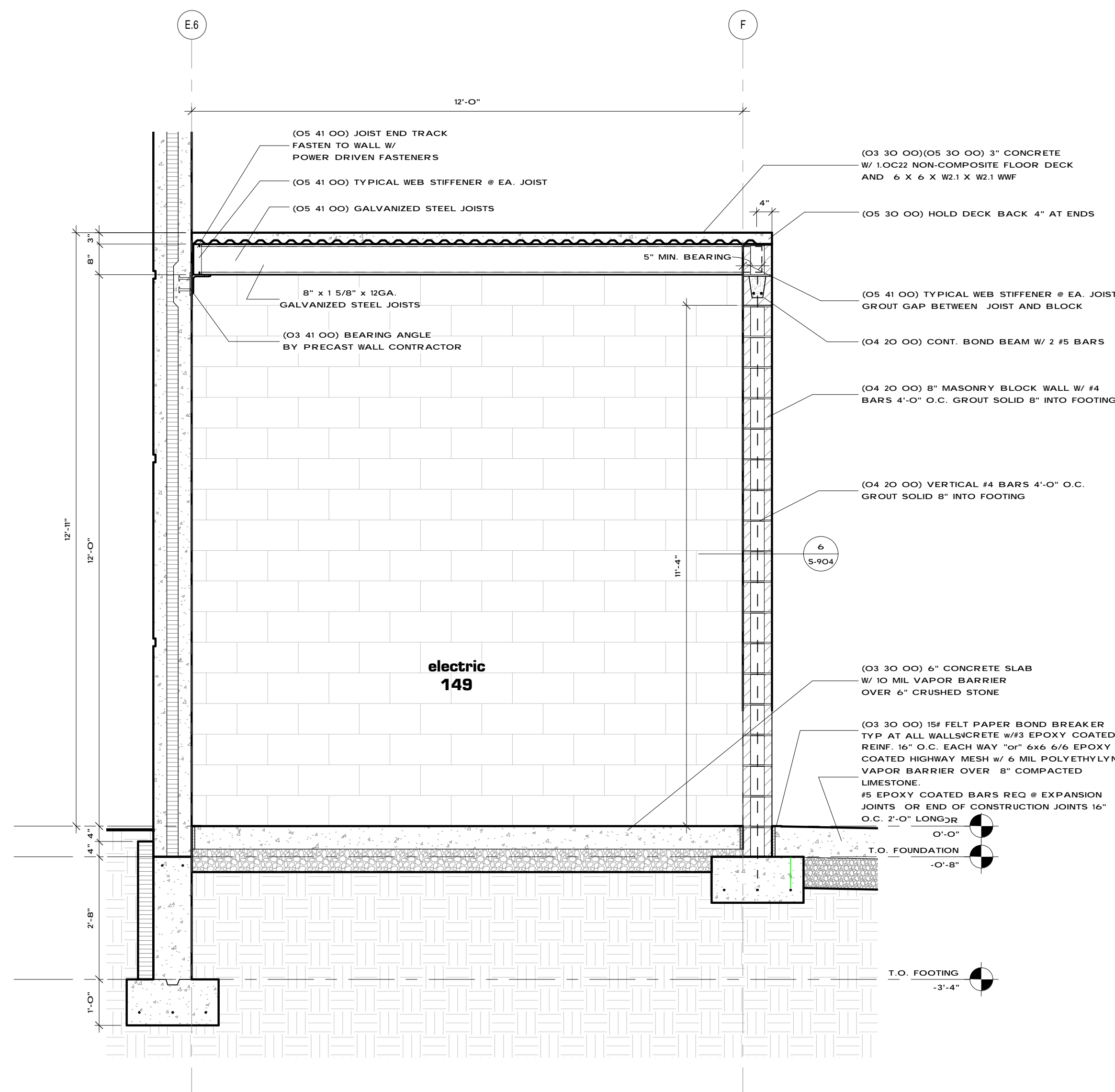

3 Equipment 149
1/2" = 1'-0"

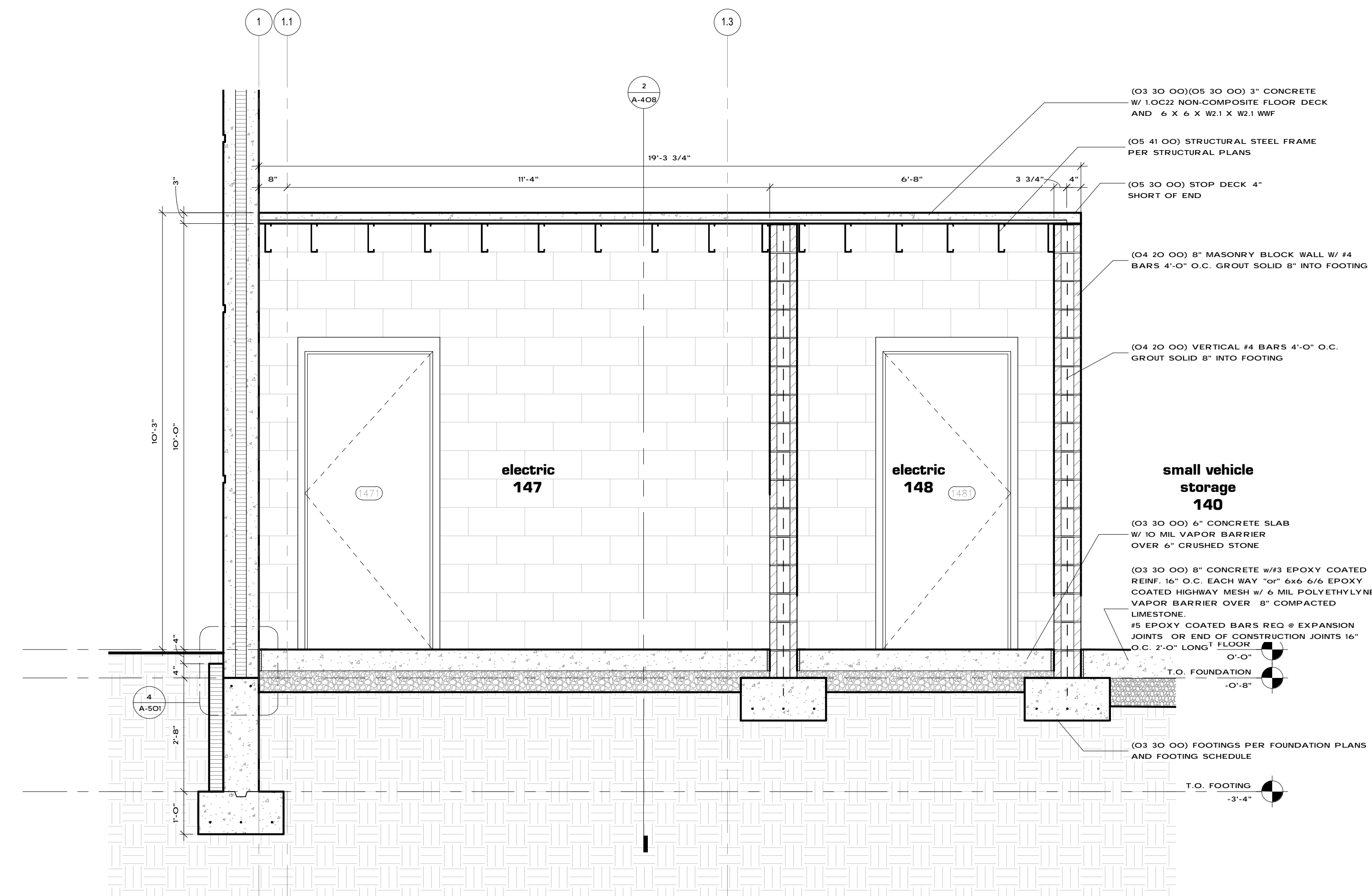

1 Section @ Electrical Rooms 147 & 148
1/2" = 1'-0"

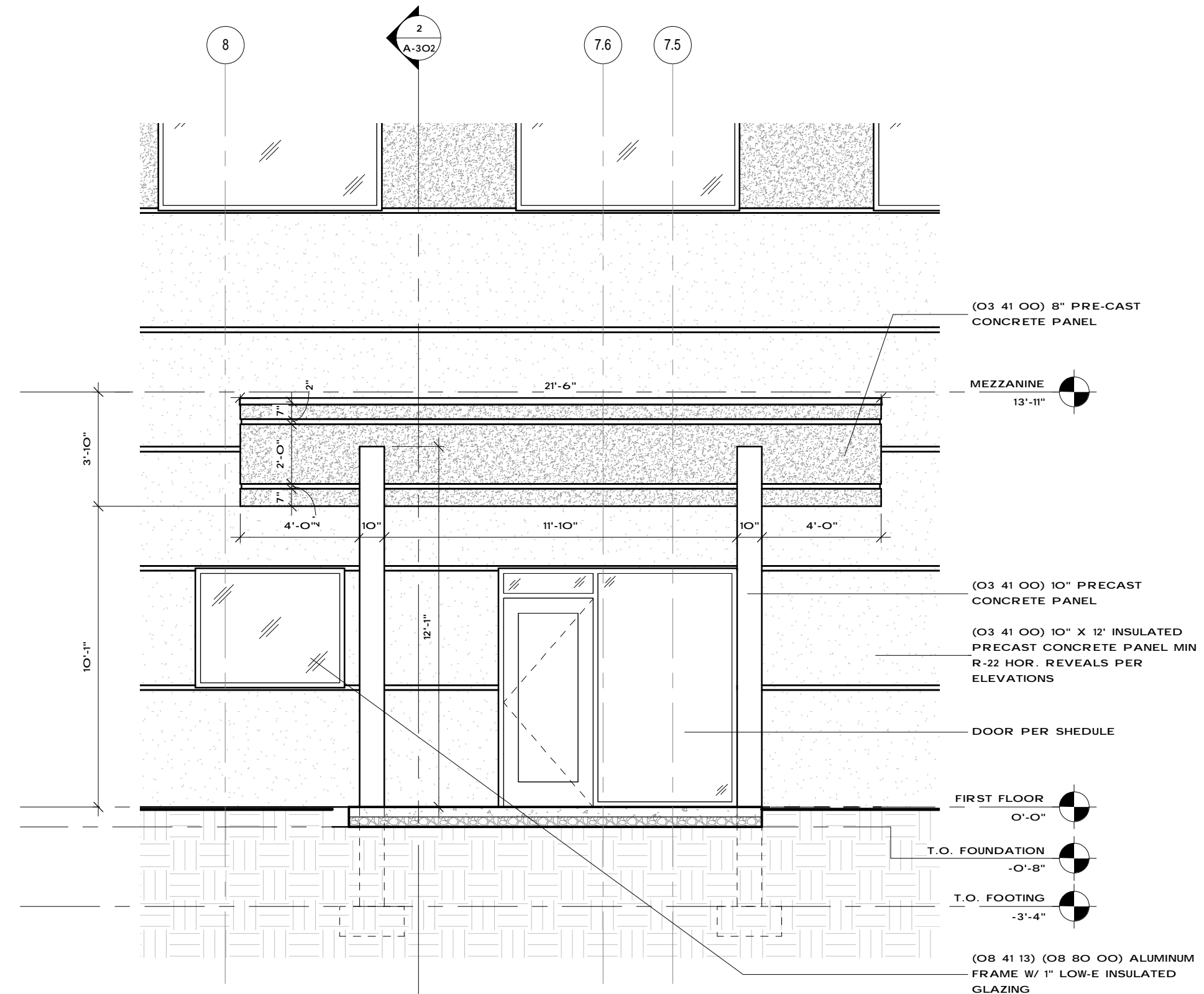

5 Entrance Elevation
1/4" = 1'-0"

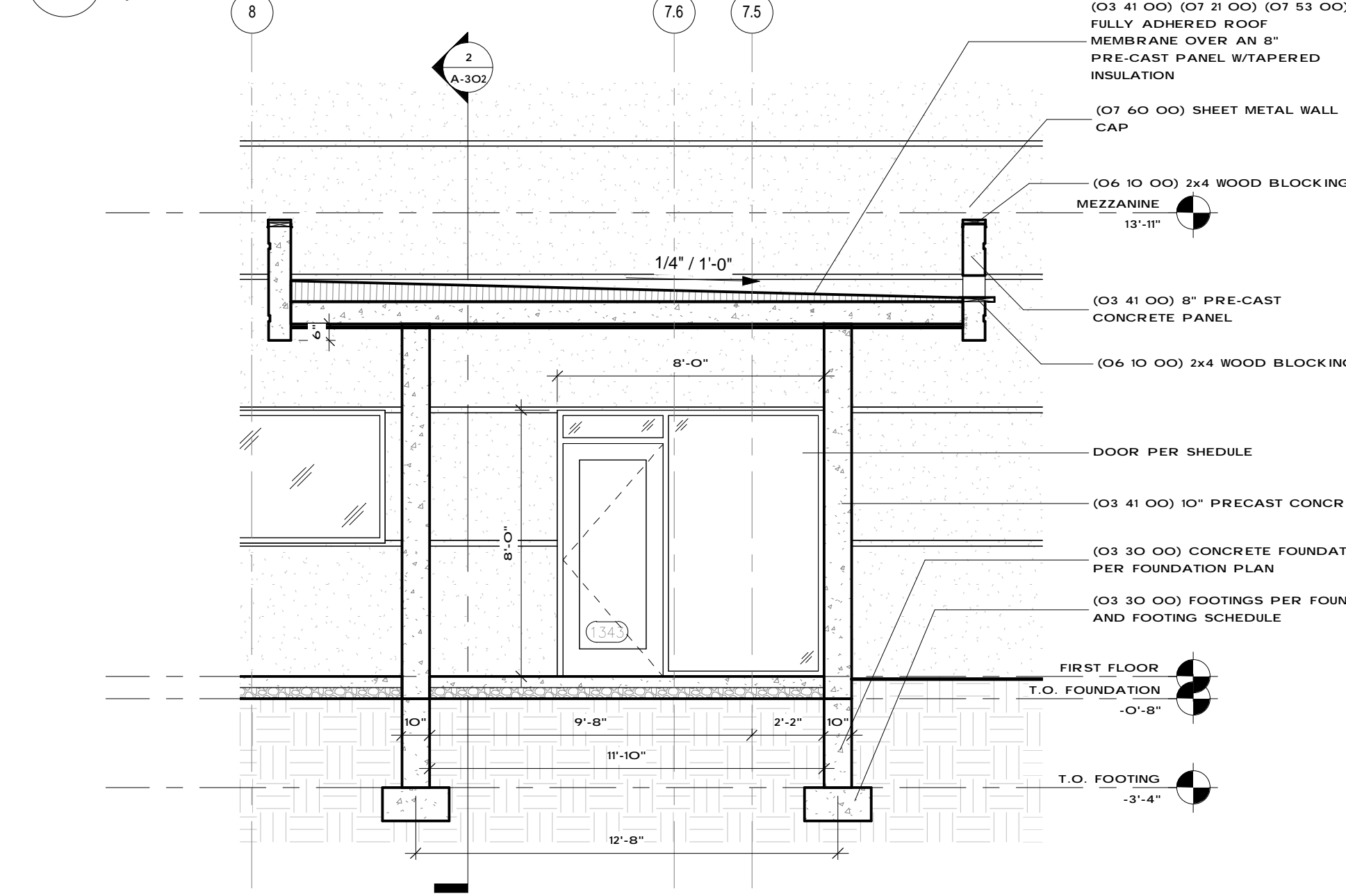

6 Entrance Canopy Section
1/4" = 1'-0"

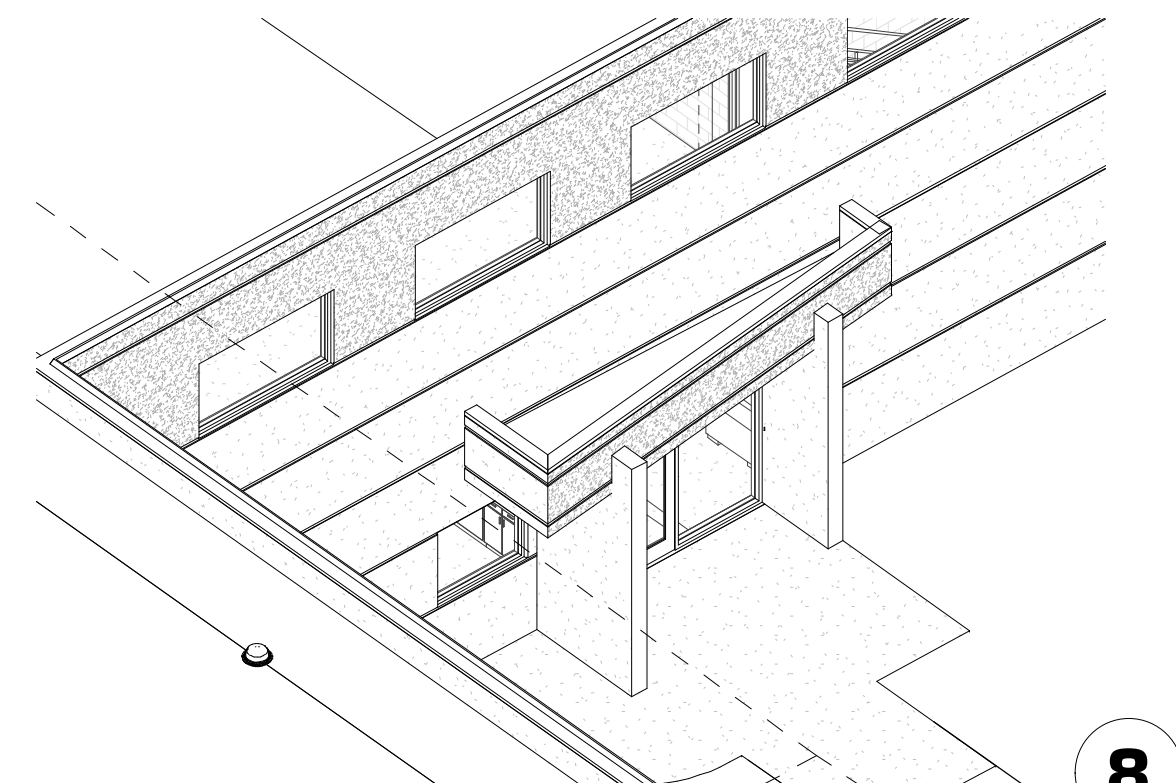

8 Entrance 3D View

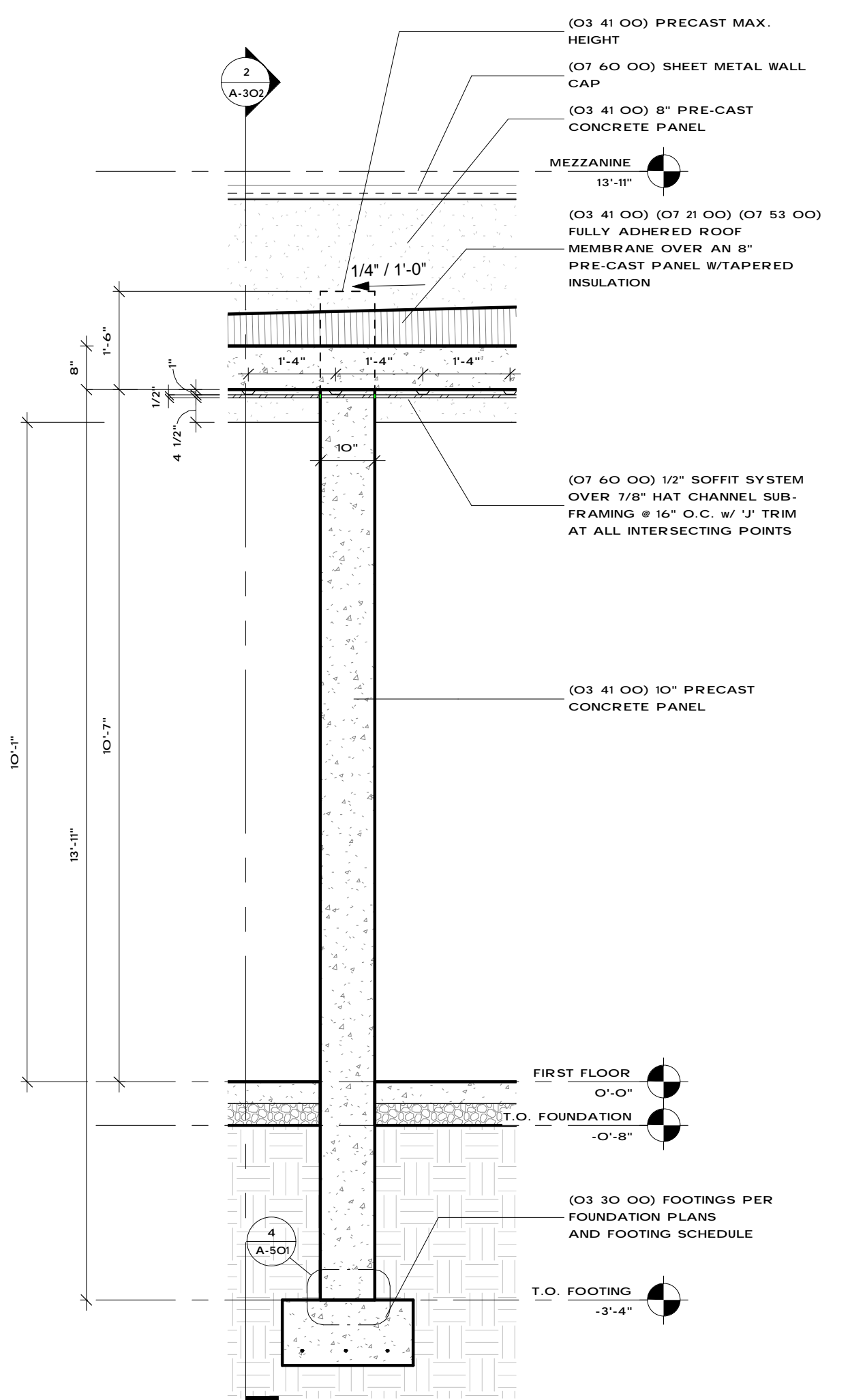

4 Entrance Typ. Wall Section
1/2" = 1'-0"

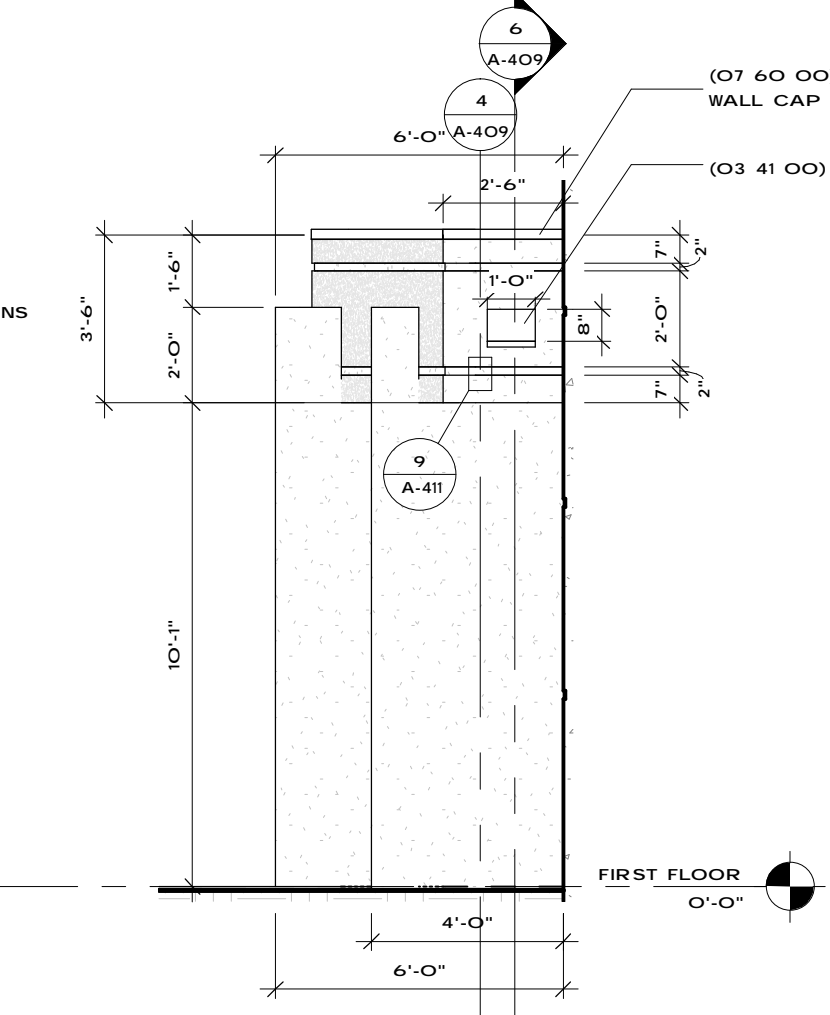

7 Entrance West Elevation
1/4" = 1'-0"

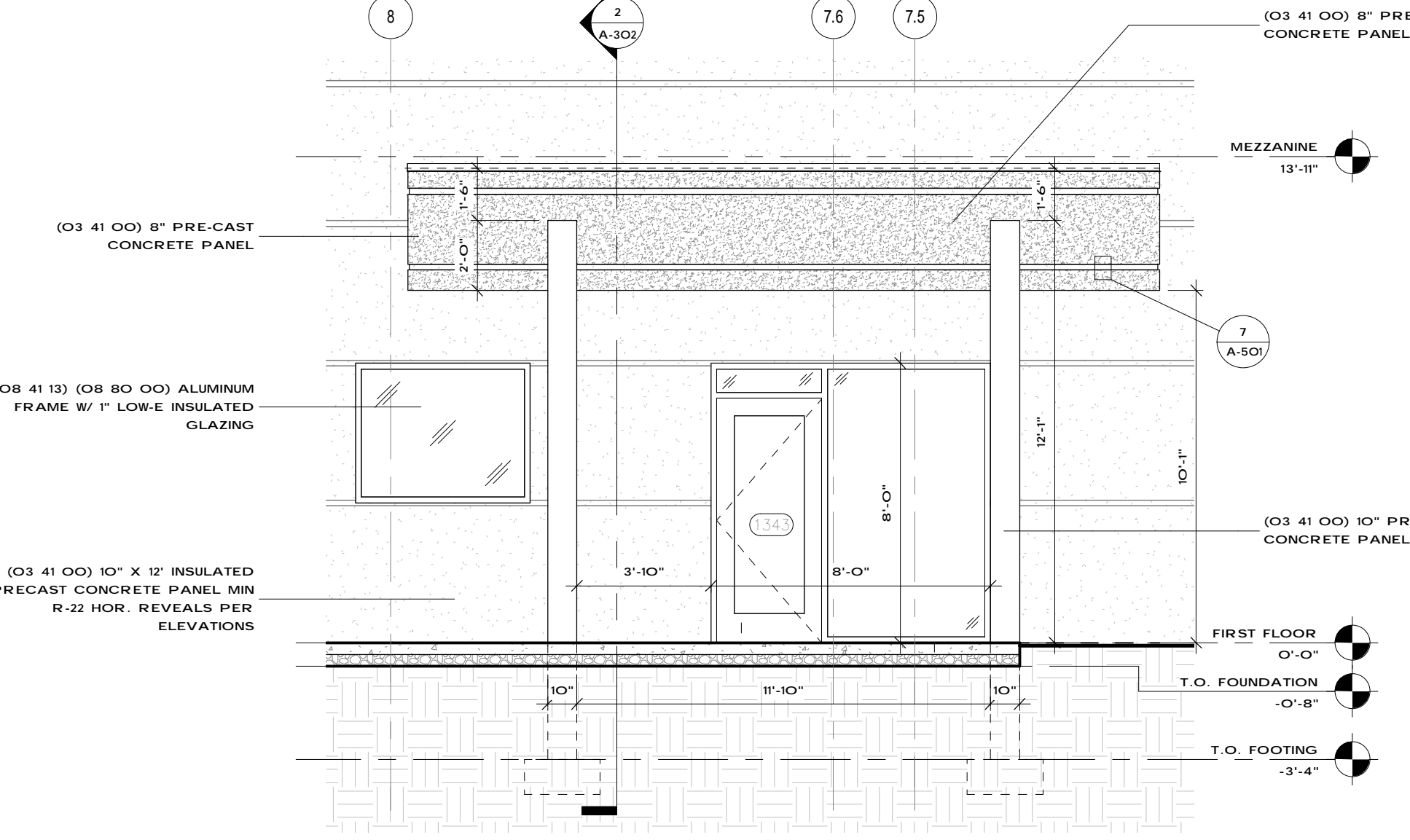

9 Entrance North Elevation
1/4" = 1'-0"

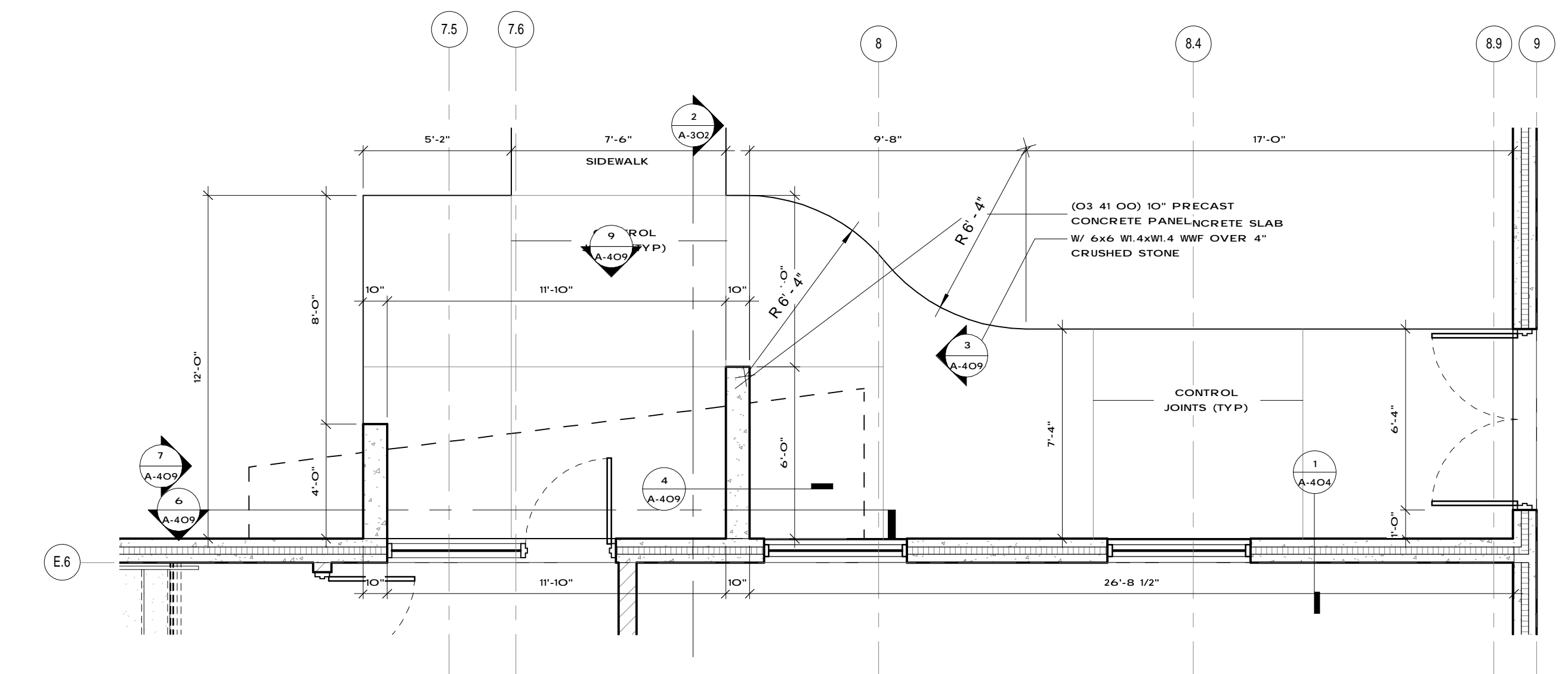

1 Entrance Detail Floor Plan
1/4" = 1'-0"

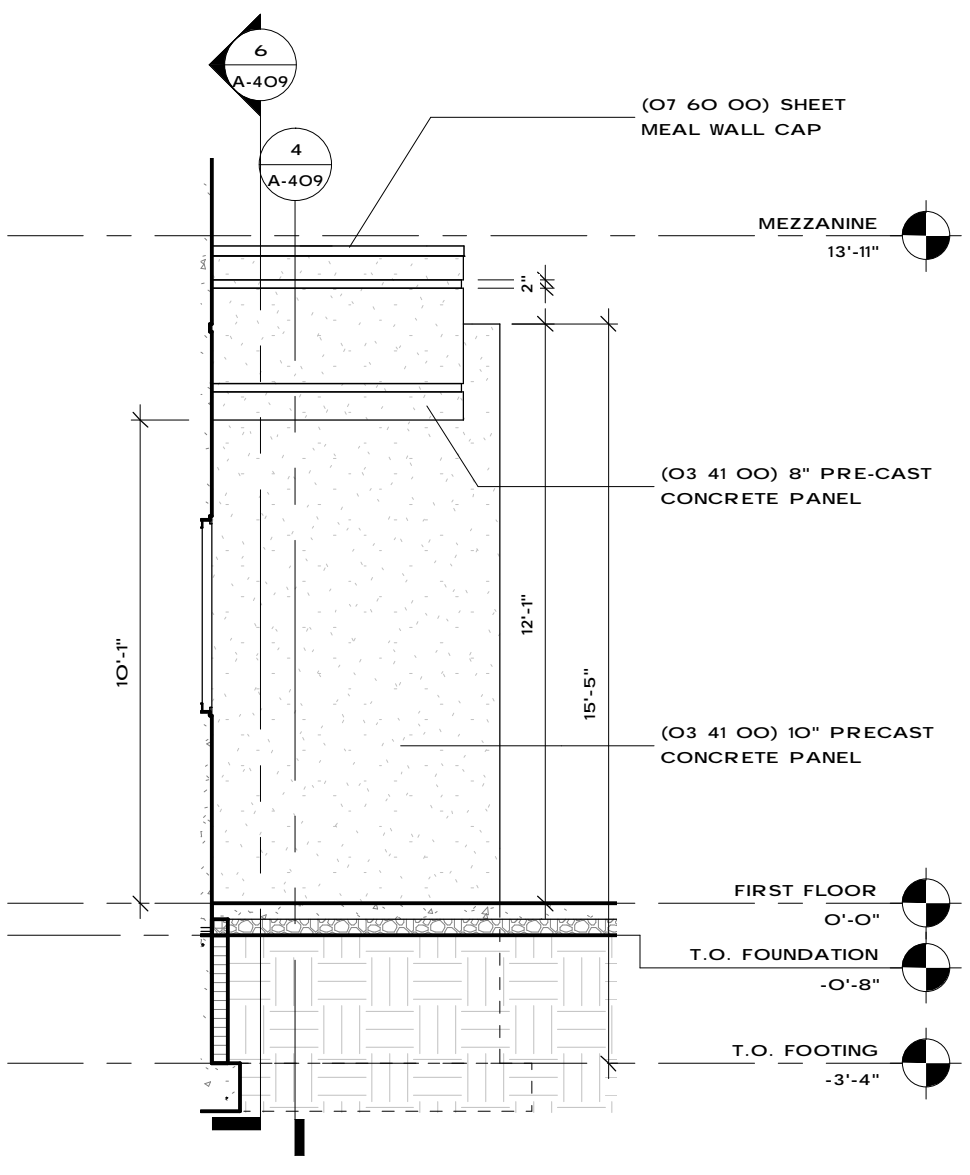

3 Entrance East Elevation
1/4" = 1'-0"

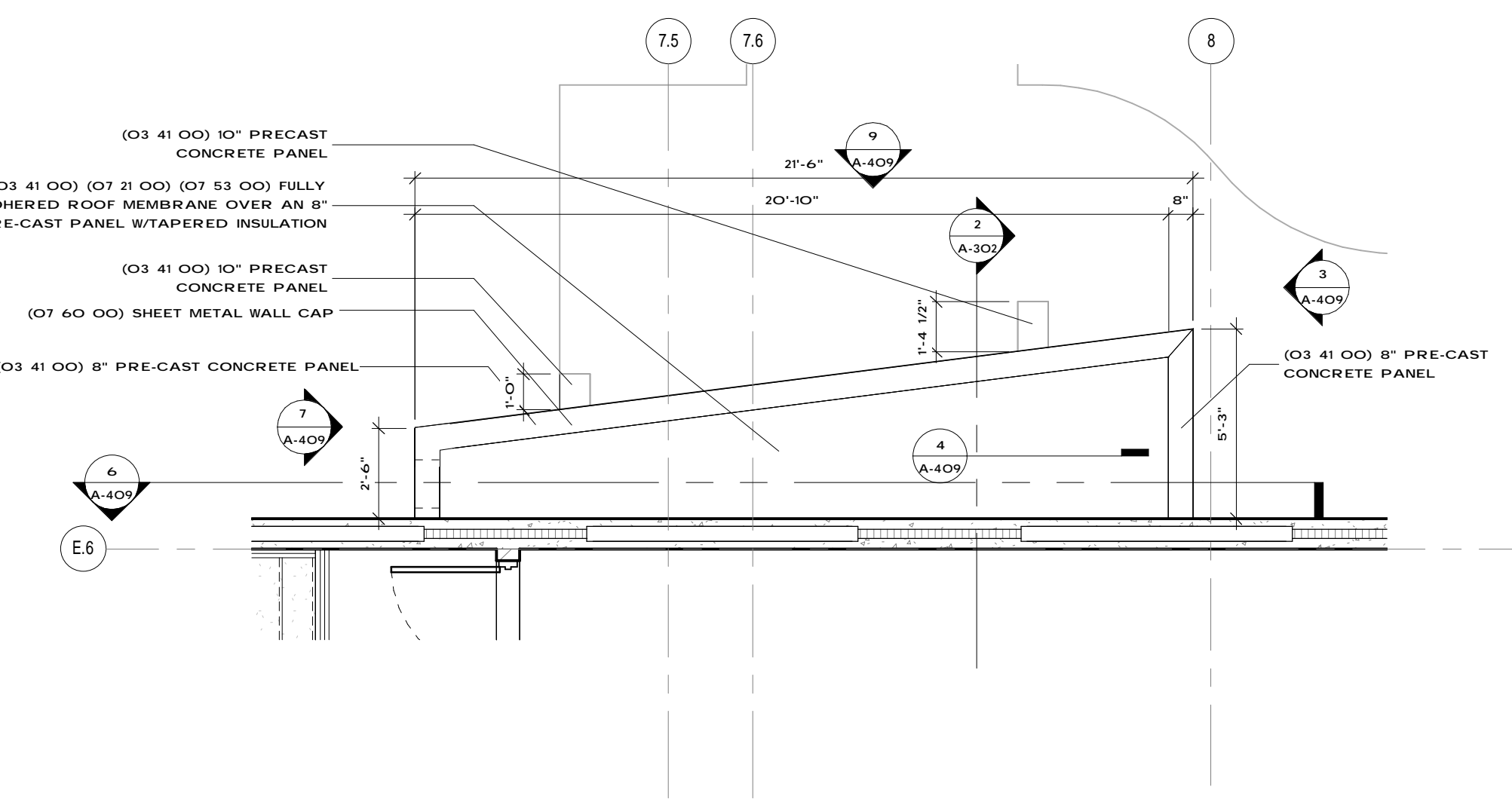

2 Entrance Roof Plan
1/4" = 1'-0"

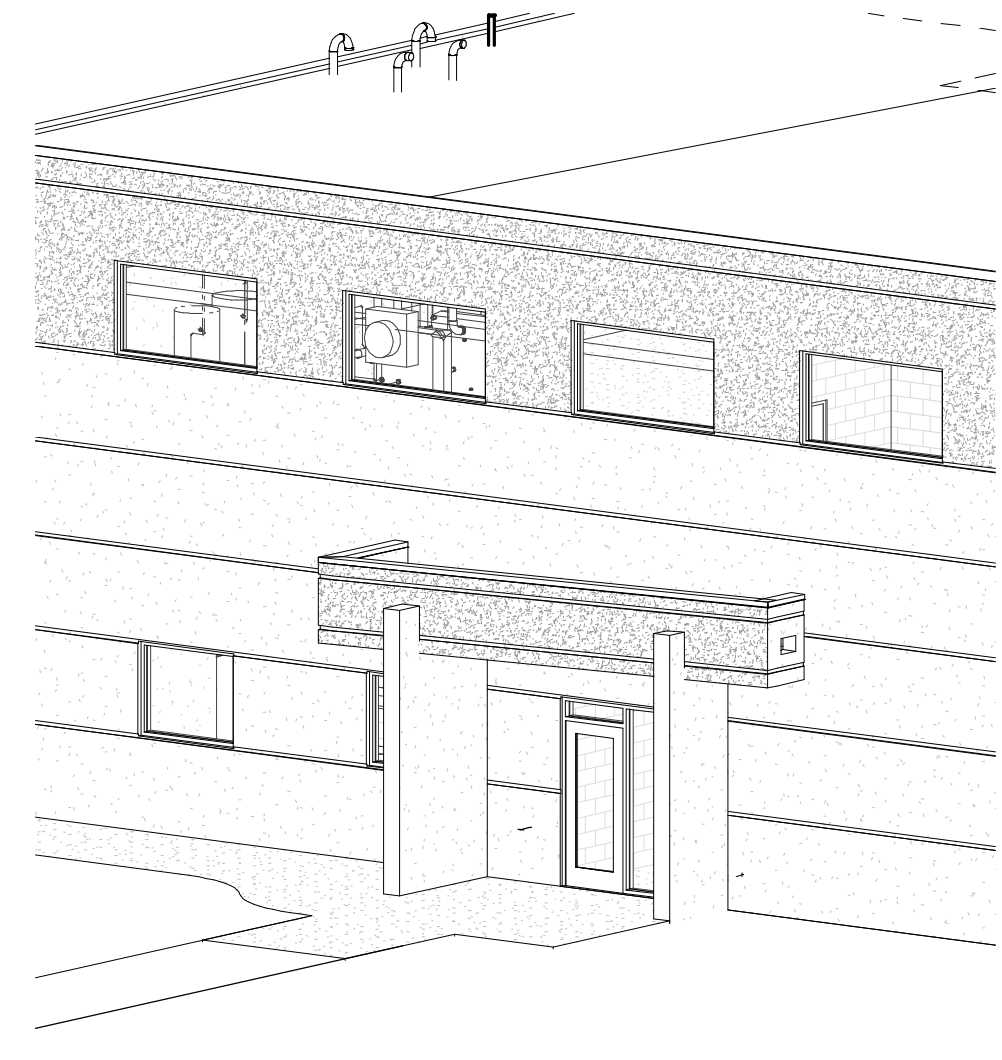

10 Entrance 3D View

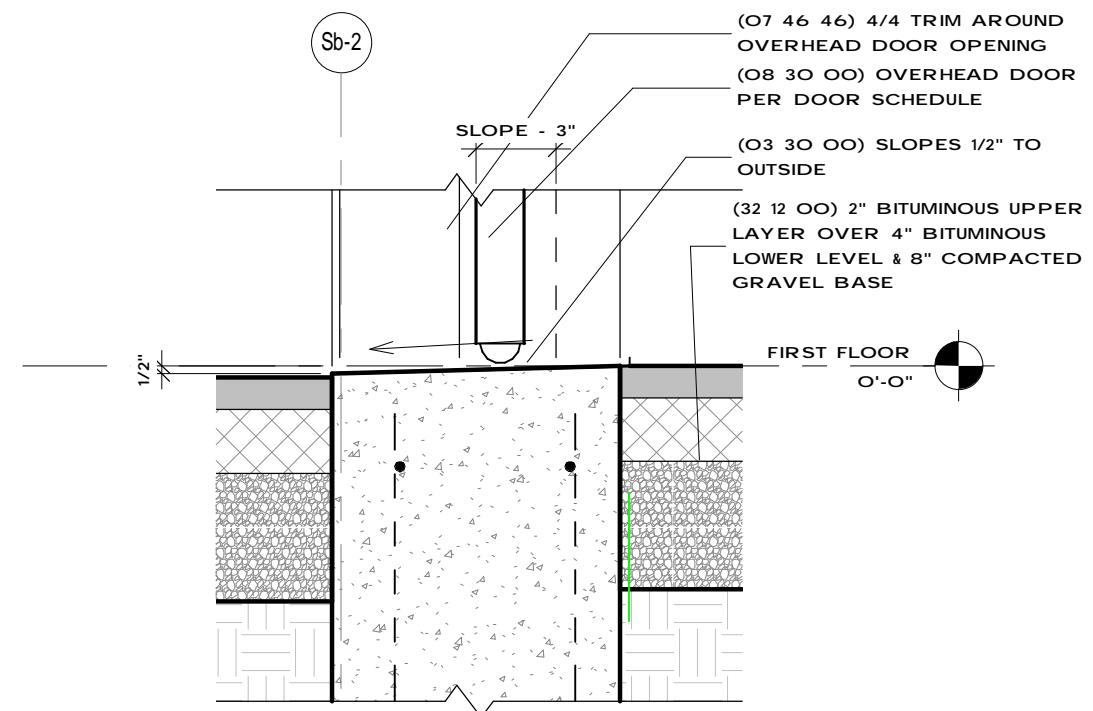

6 Salt Building - Slab Detail @ OH Door
1" = 1'-0"

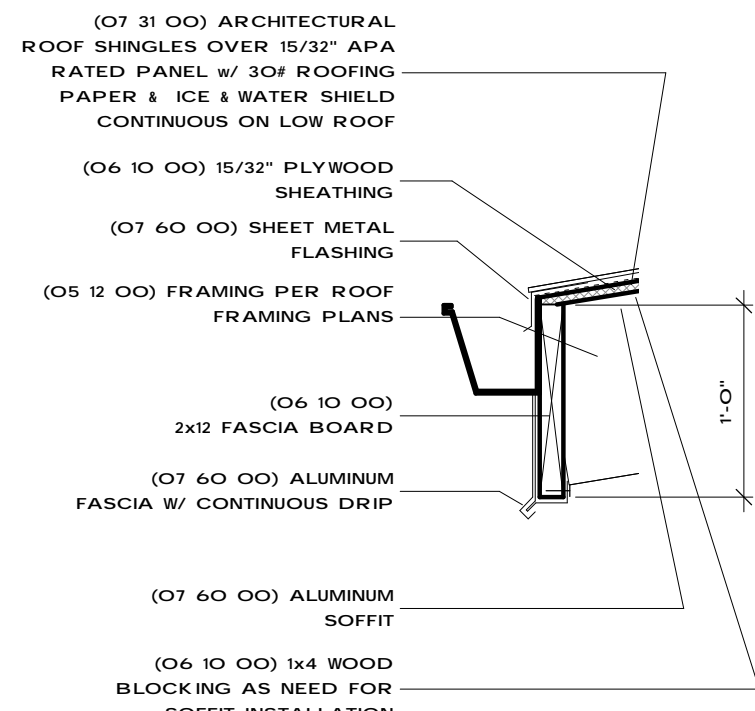

4 Salt Building - Fascia Board Detail
1" = 1'-0"

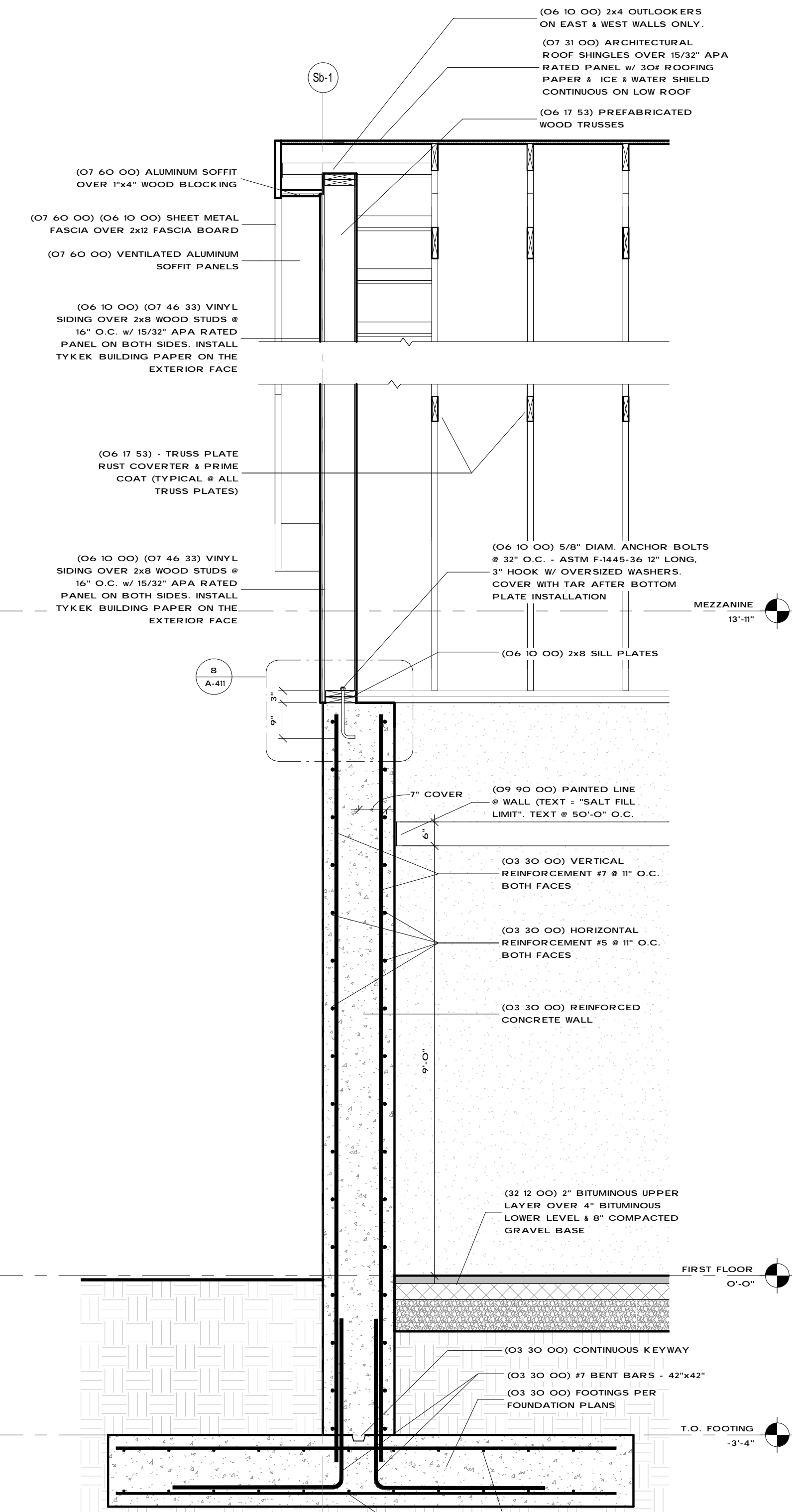

5 Salt Building - Wall Section West
1/2" = 1'-0"

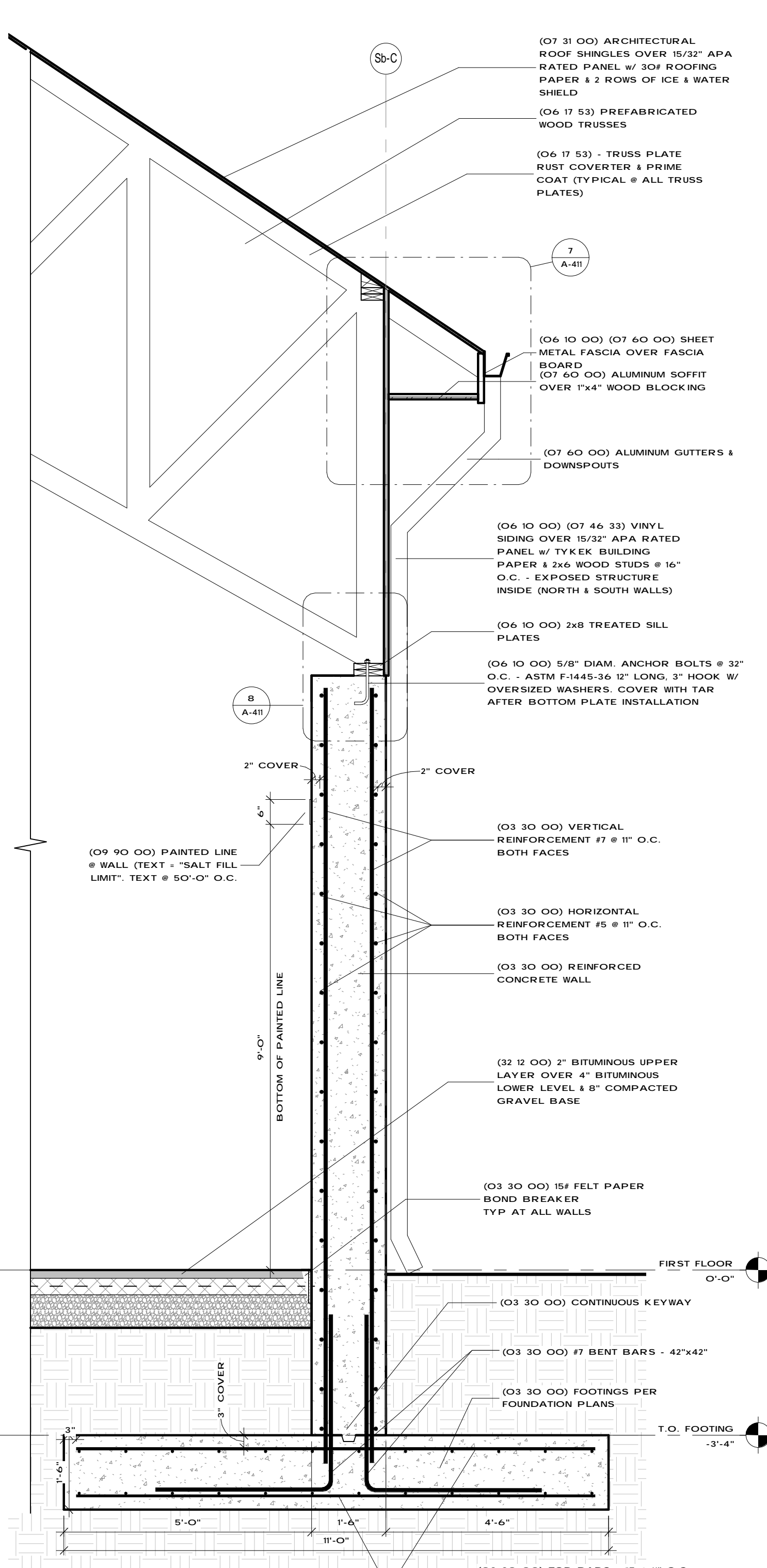

3 Salt Building - Wall Section 3
1/2" = 1'-0"

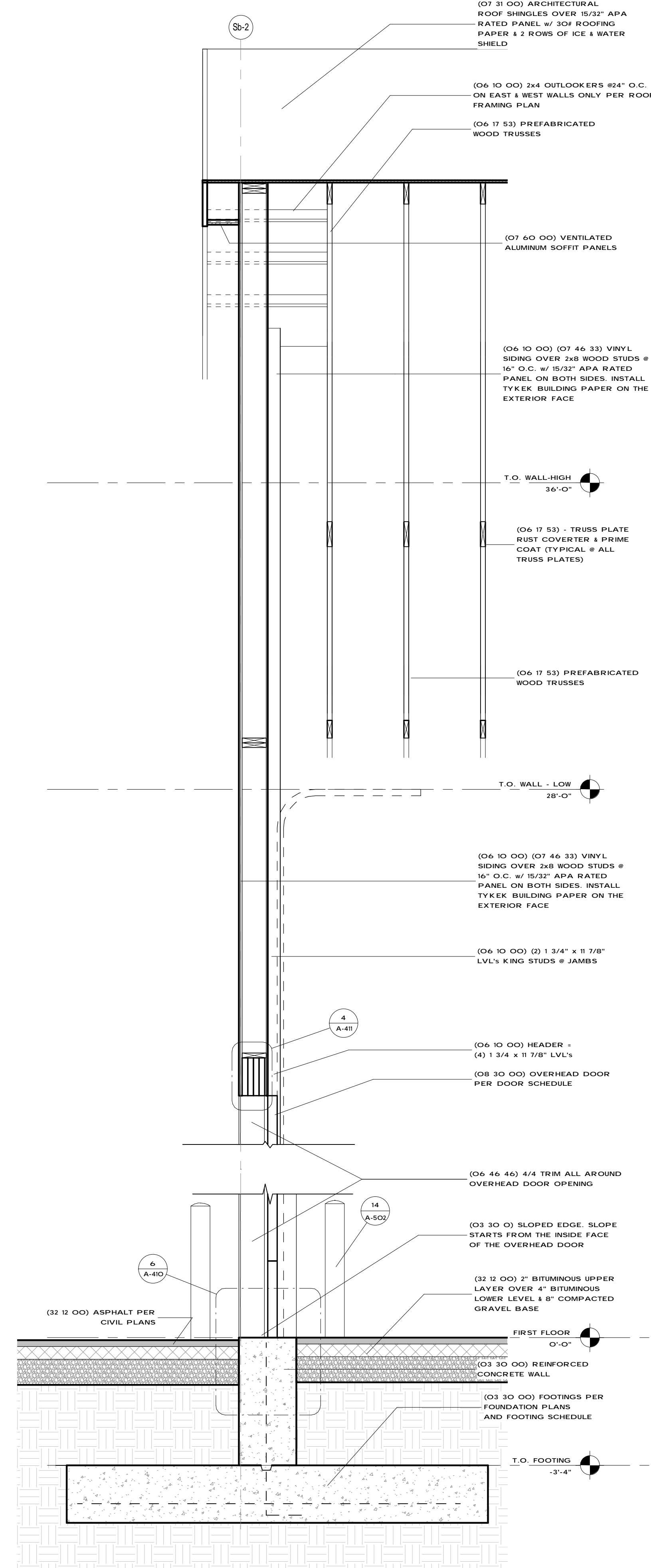

2 Salt Building - Wall Section @ OH Door
1/2" = 1'-0"

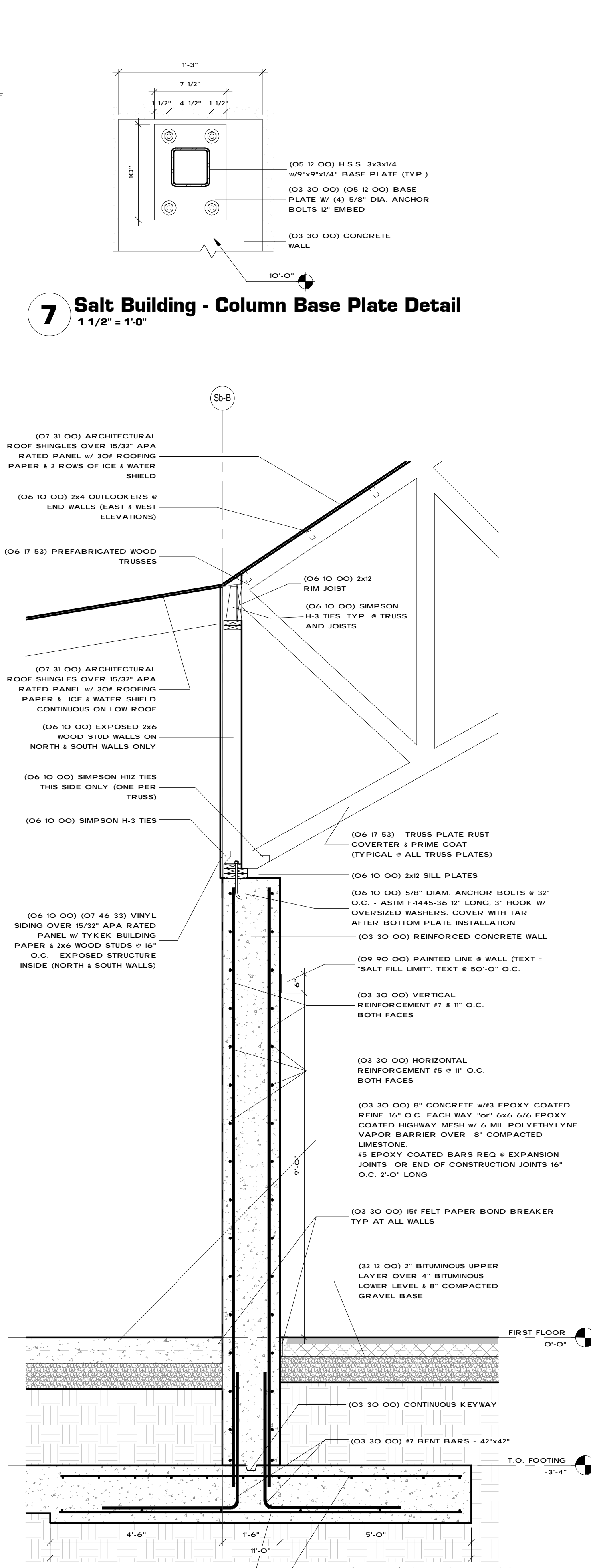

1 Salt Building - Wall Section 1
1/2" = 1'-0"

7 Salt Building - Column Base Plate Detail
1 1/2" = 1'-0"

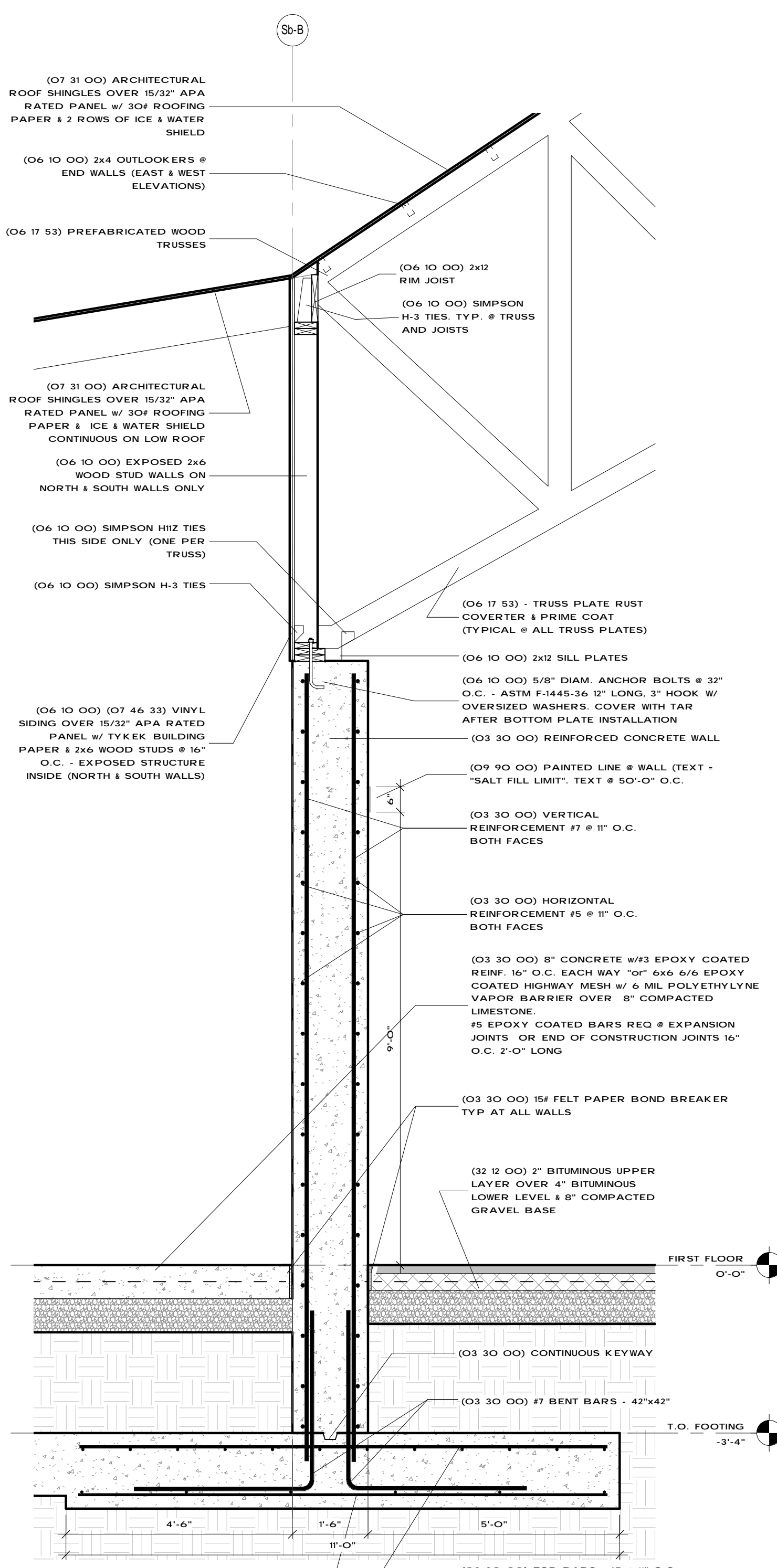

LOAD SYSTEM @ SALT BUILDING	
LIVE LOAD (SNOW)	25.2 P.S.F.
DEAD LOAD	12.0 P.S.F.
TOP CHORD	10.0
BOTTOM CHORD	2.0
	14.8
DESIGN LOAD	36 P.S.F.
WIND LOAD	
BASIC WIND SPEED	90 MPH
IMPORTANCE FACTOR	1.0
EXPOSURE CATEGORY	C
PARTIALLY ENCLOSED	
SEISMIC LOAD	
SITE CLASS	D
SDS	0.116
SD1	0.072
SEISMIC DESIGN CATEGORY	B

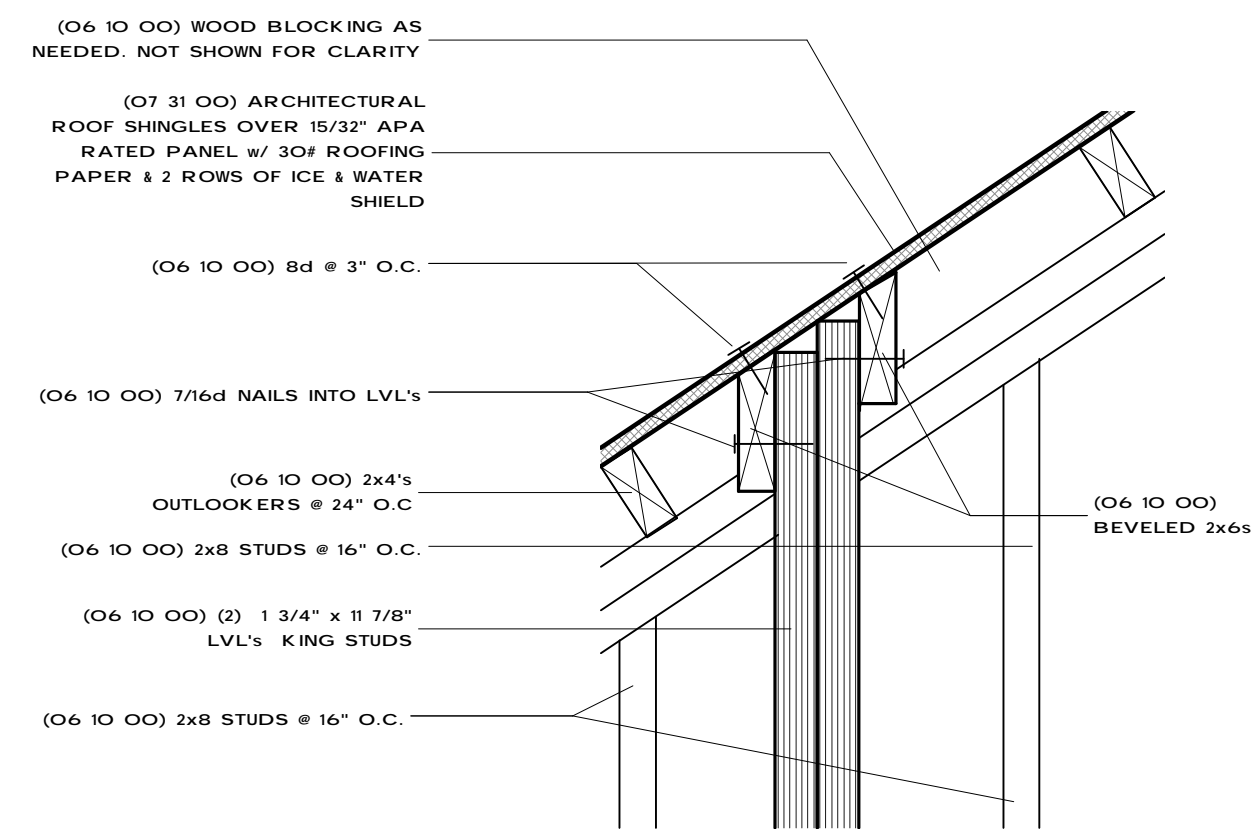

5 Jamb Detail @ Top of Wall
1 1/2" = 1'-0"

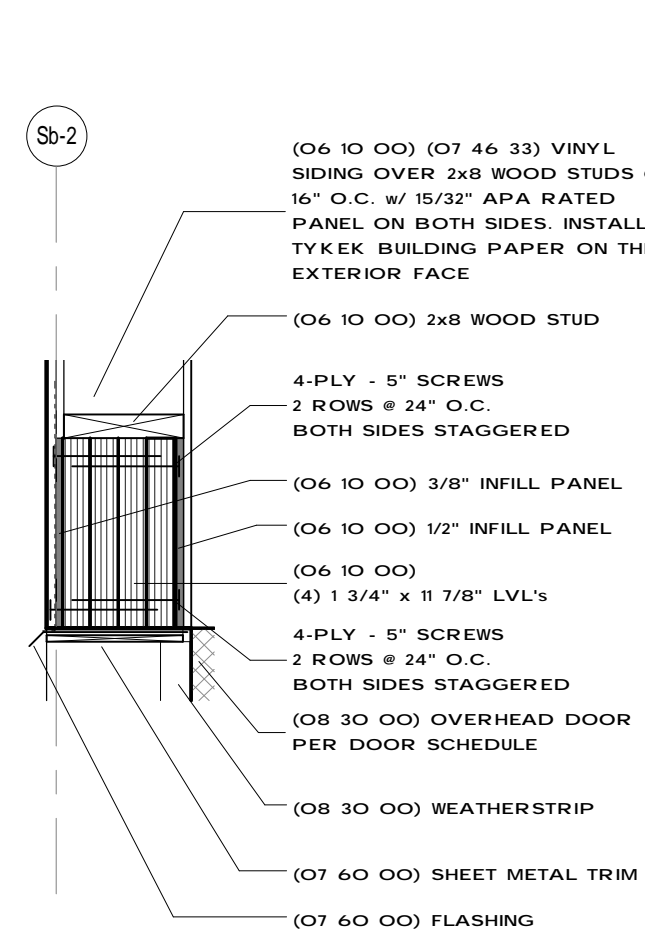

4 OH Header Fastening @ Plys
1" = 1'-0"

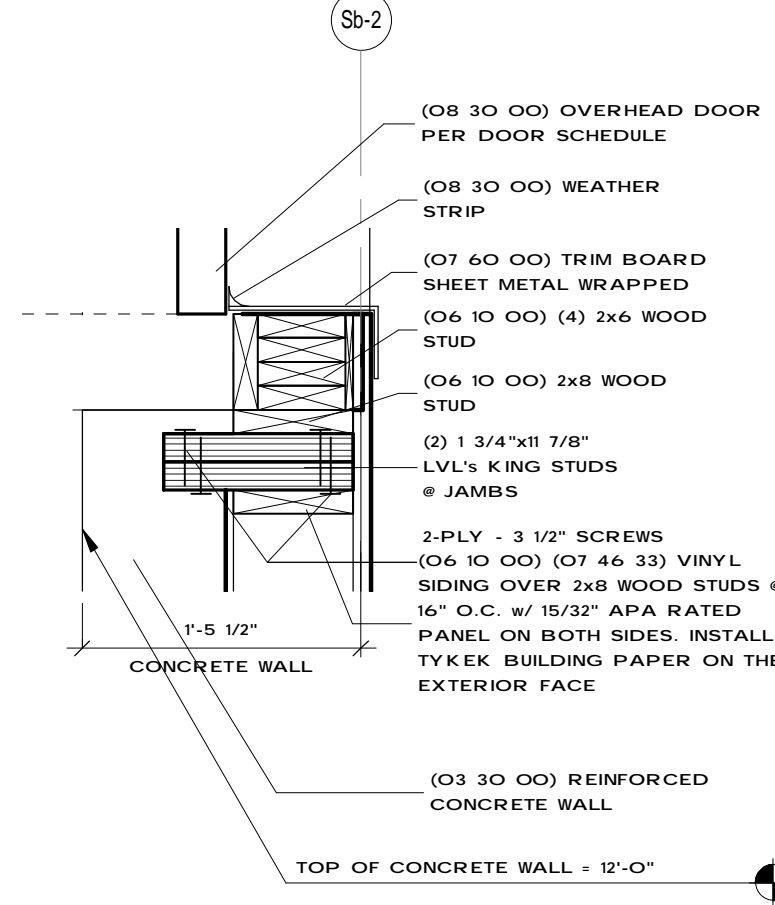

3 King Stud Fastening @ Plys
1" = 1'-0"

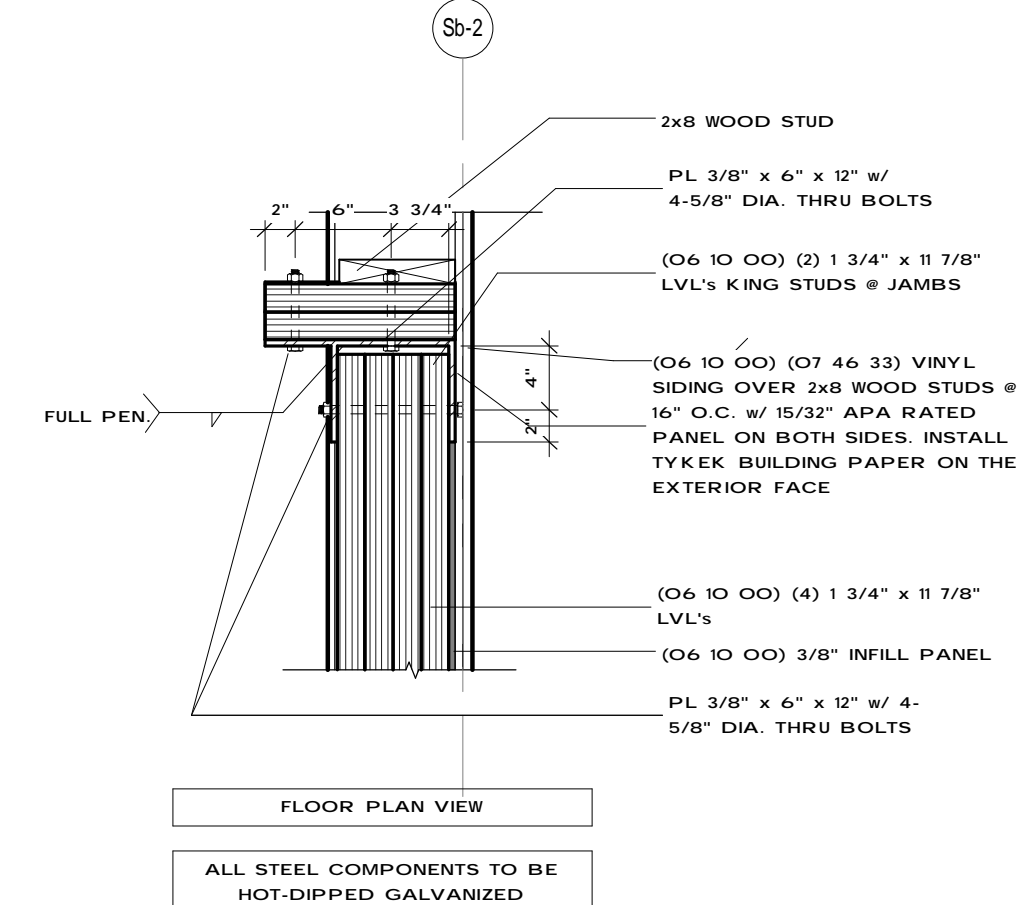

2 Jamb Detail @ OH Door Header
1" = 1'-0"

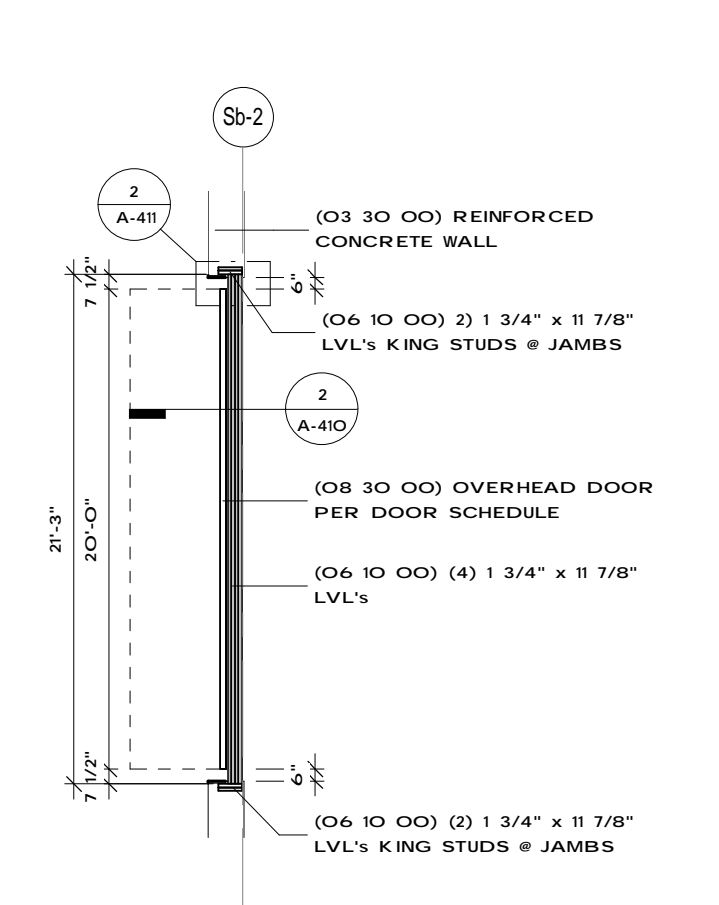

1 OH Door Framing
1/8" = 1'-0"

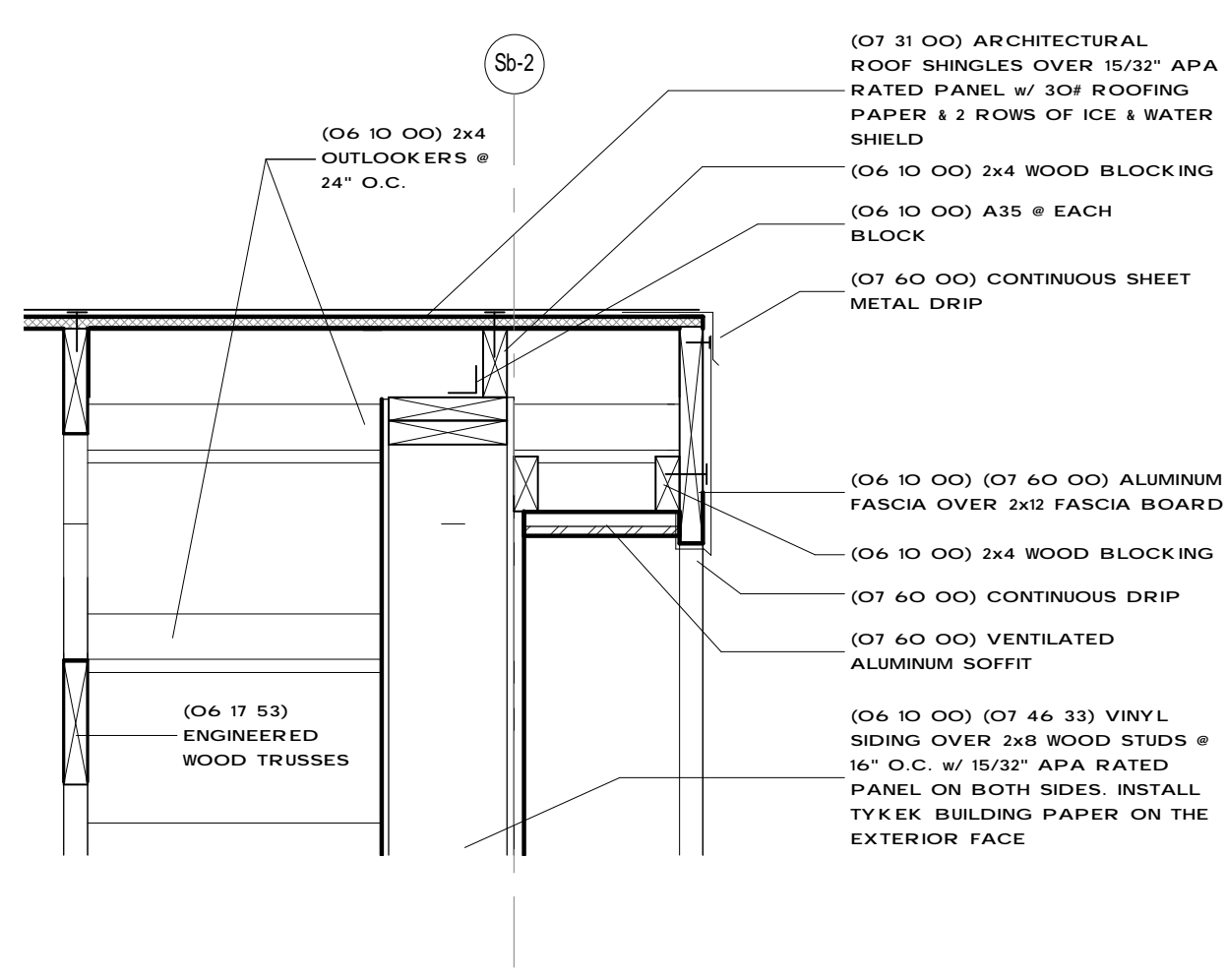

9 Outlooker Detail
1" = 1'-0"

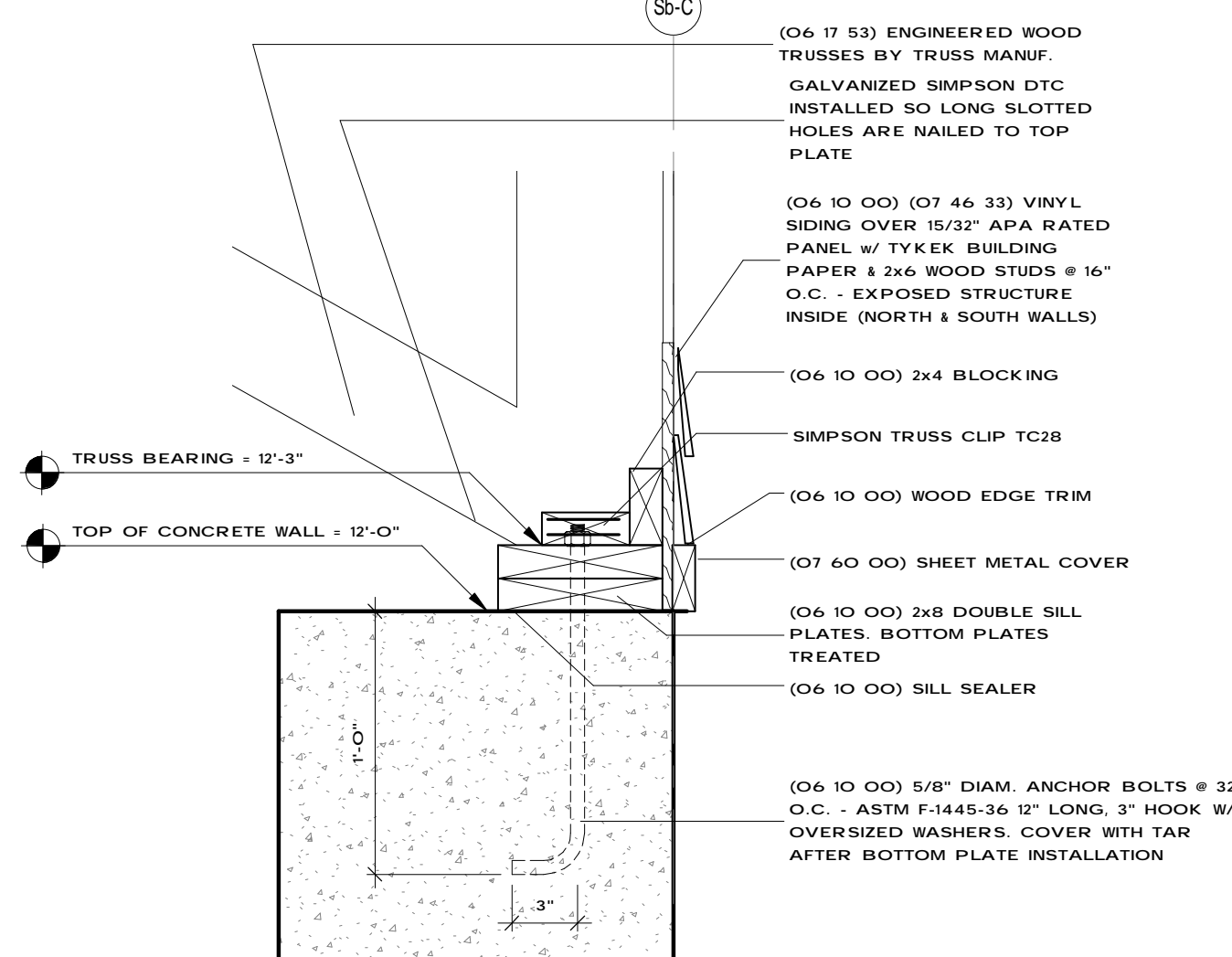

8 Truss Bearing Detail
1 1/2" = 1'-0"

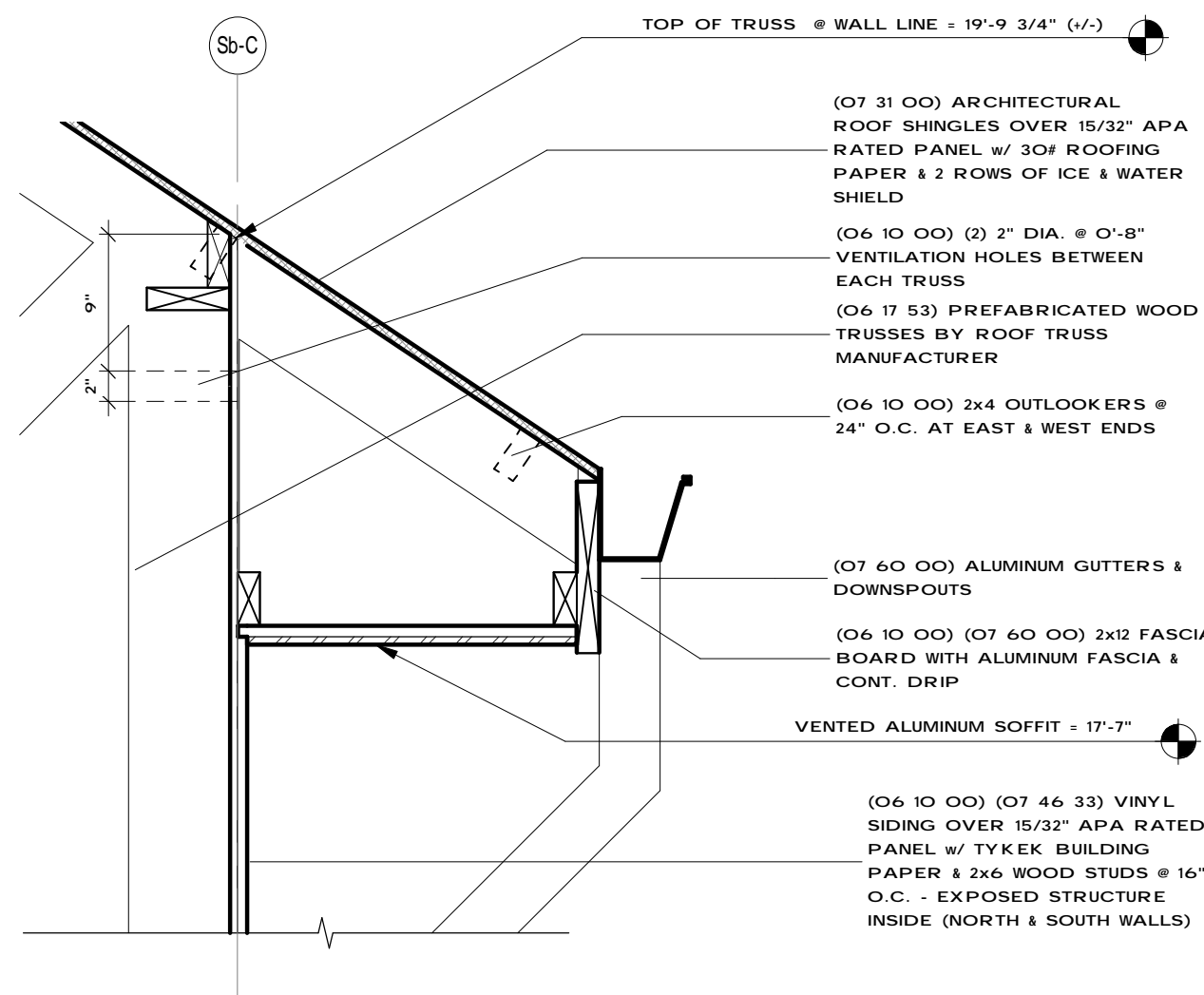

7 Soffit Fascia Detail
1" = 1'-0"

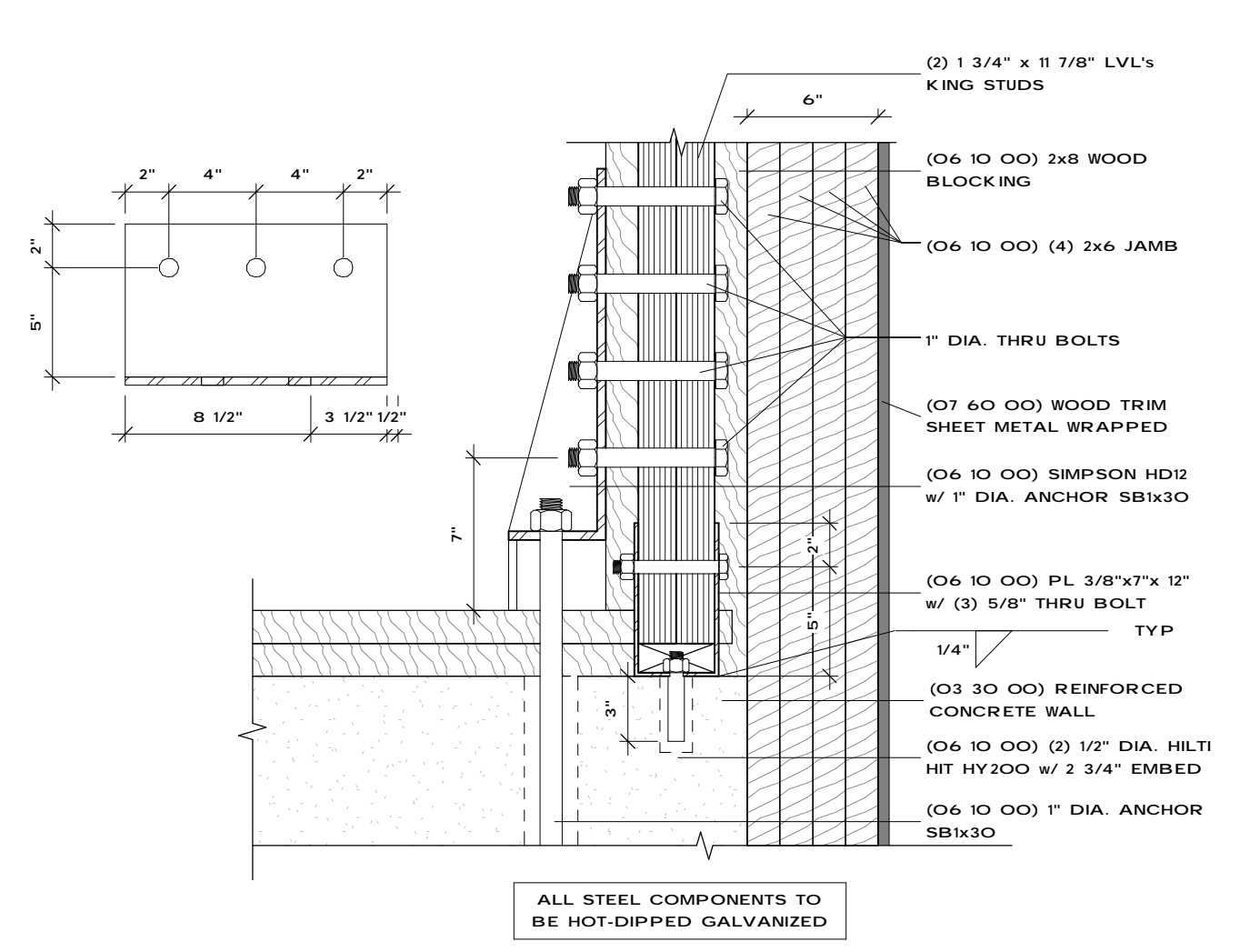

6 Jamb Detailing @ Concrete Wall
1 1/2" = 1'-0"

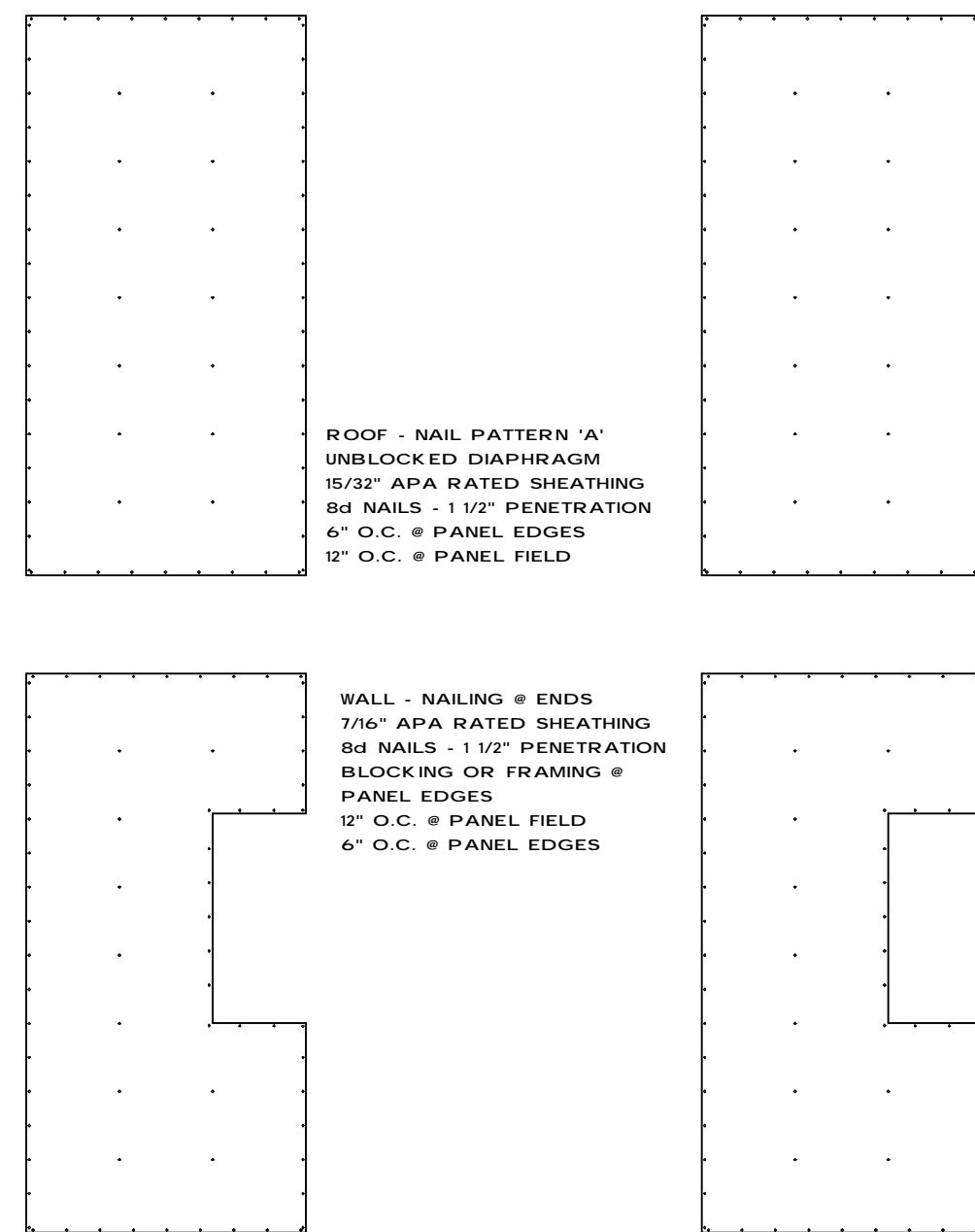

13 Roof/Wall Panel Nailing Pattern
3/8" = 1'-0"

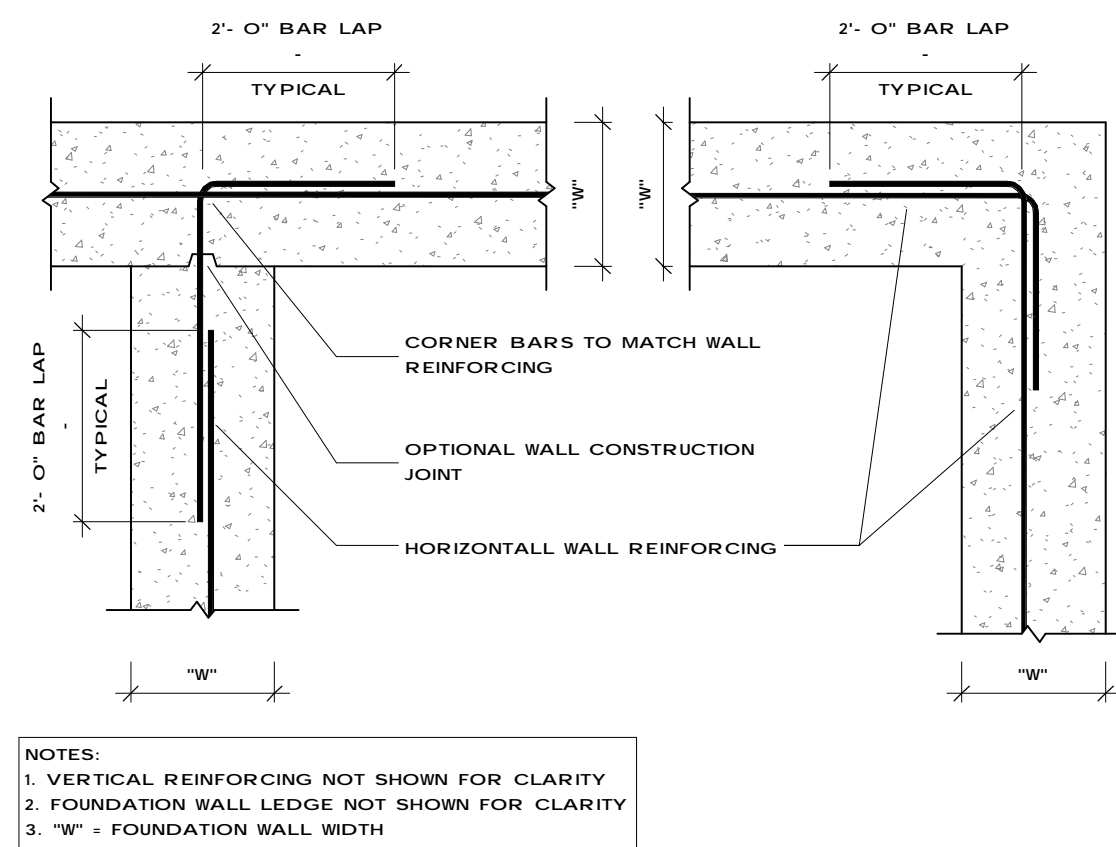

12 Foundation Corner Reinforcement

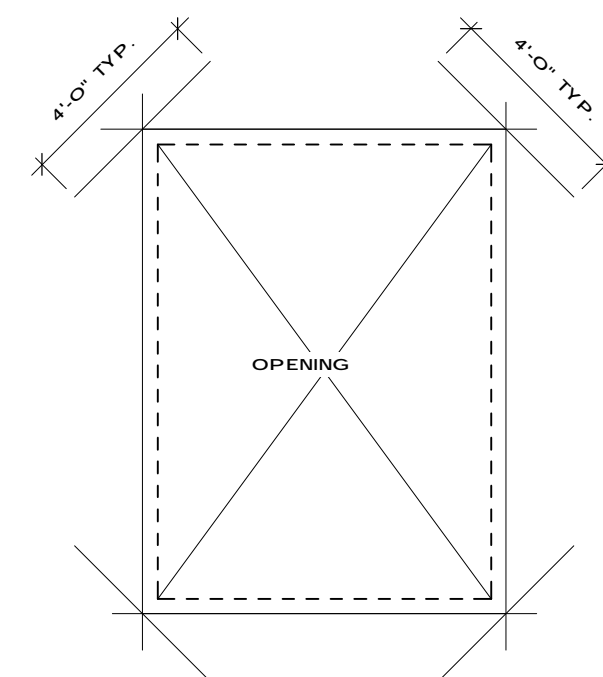

11 Foundation Wall Penetration Reinforcement

LAP LENGTH SCHEDULE	
BAR SIZE	LAP (MINIMUM)
# 5 BARS	33"
# 6 BARS	39"
# 7 BARS	45"
# 8 BARS	52"

DIAGONAL BARS:
(4) #5 BARS EACH FACE

NOTES:

- VERIFY SIZE AND LOCATION OF OPENING WITH TRADE OR SUB-CONTRACTOR REQUIRING OPENING
- SEE FOUNDATION DETAILS FOR VERTICAL AND HORIZONTAL WALL REINFORCEMENTS

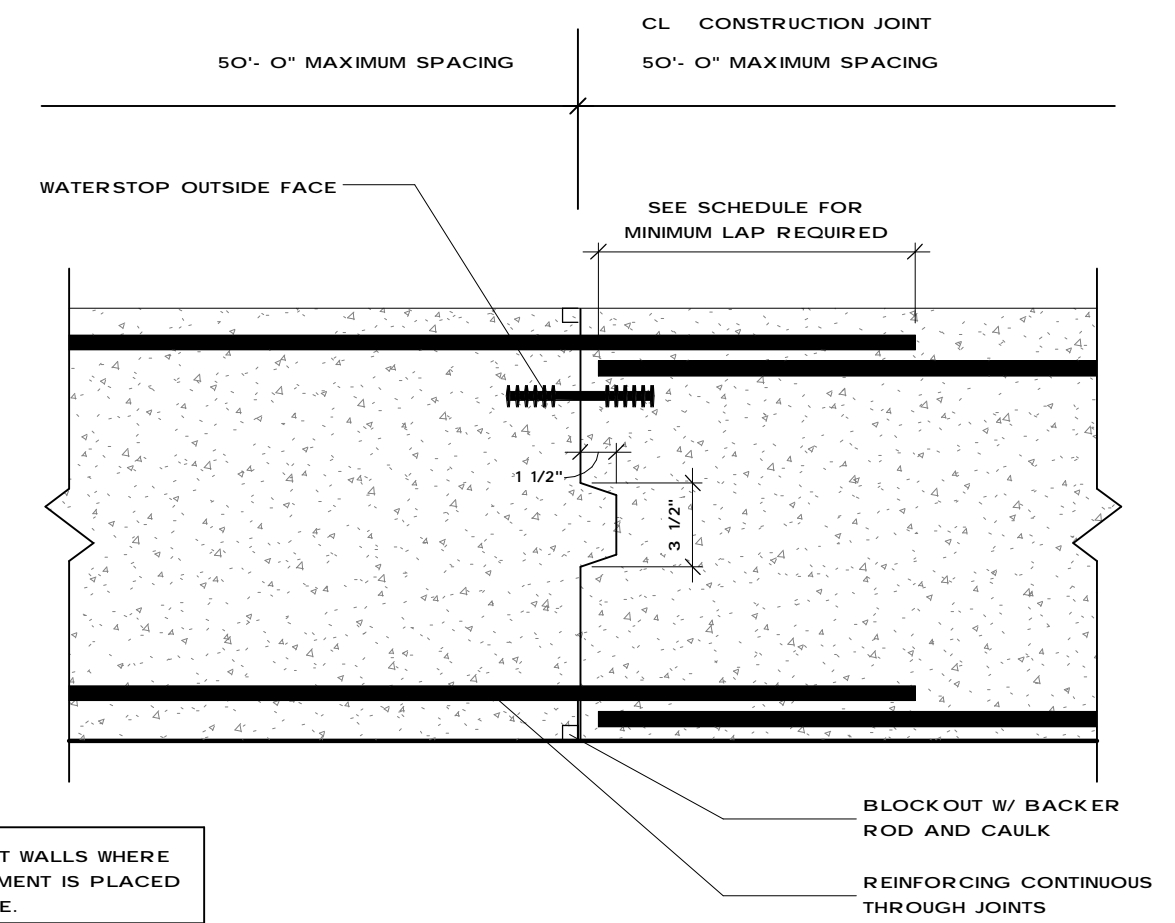

10 Foundation Wall Construction Joint

SIMILAR AT WALLS WHERE REINFORCEMENT IS PLACED EACH FACE.

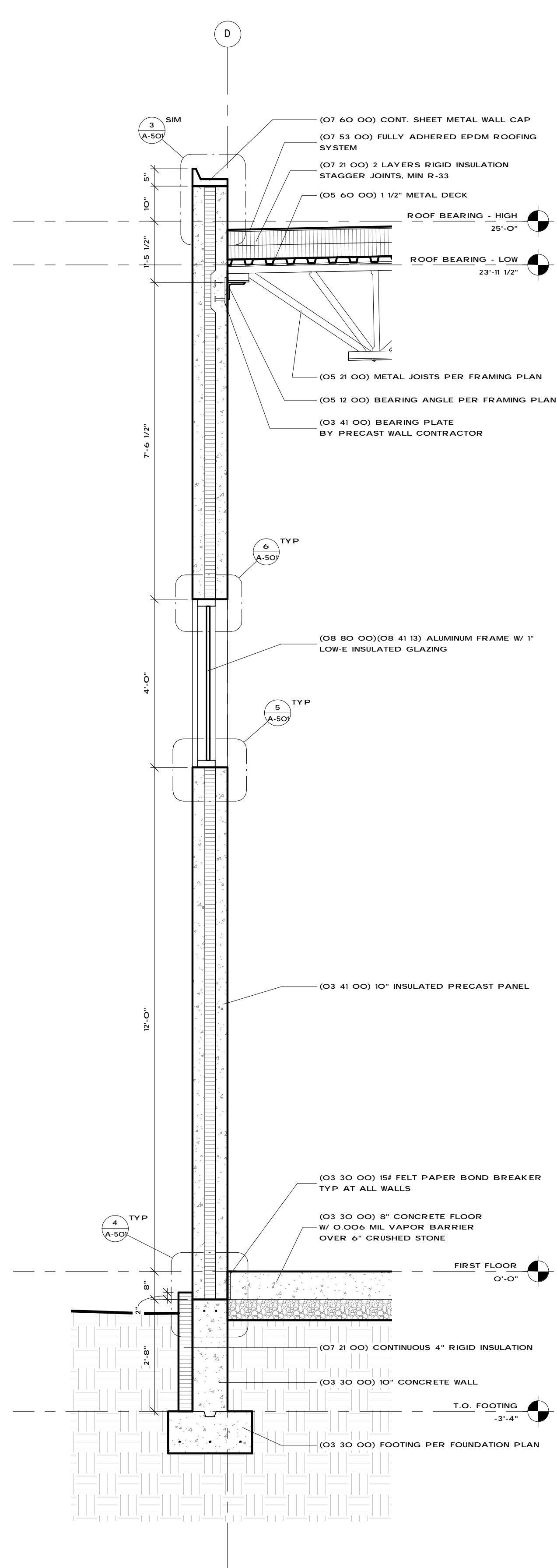

1 Wall Section
1/2" = 1'-0"

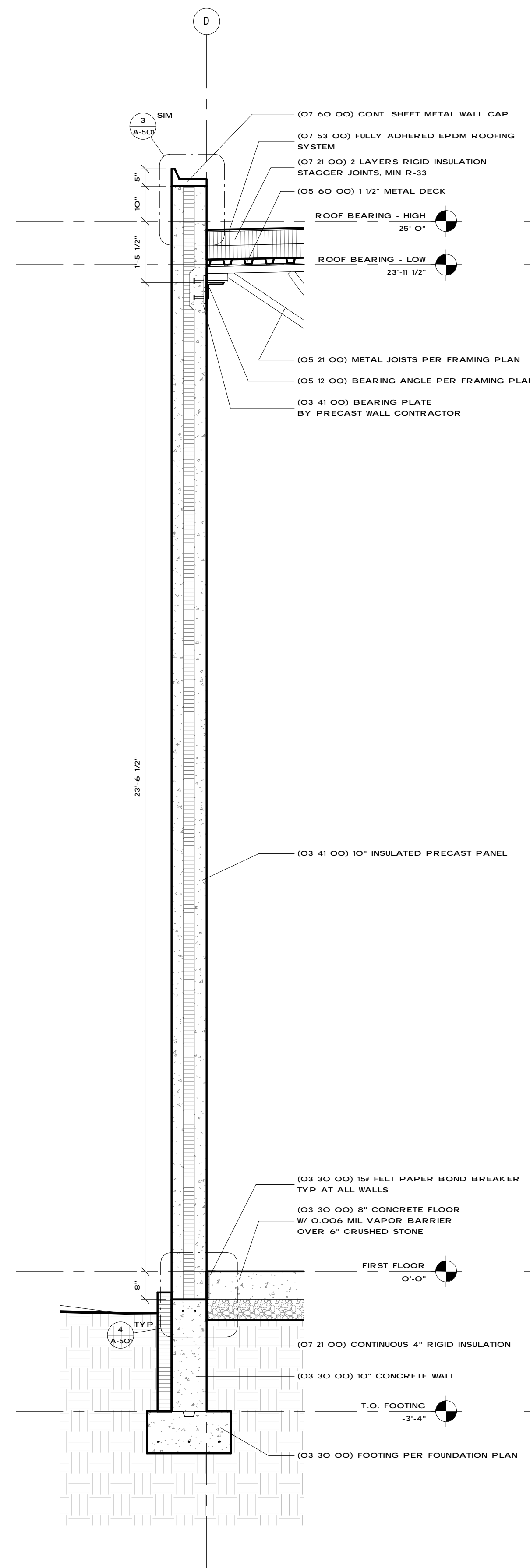

2 Wall Section
1/2" = 1'-0"

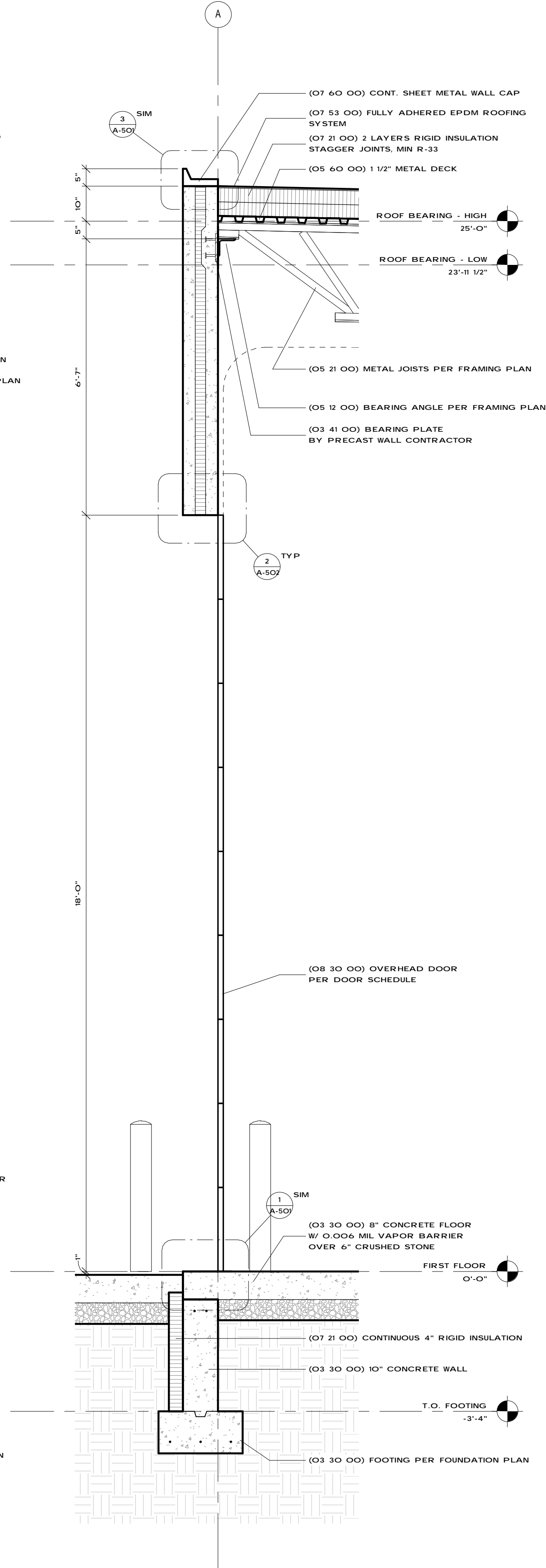

3 Wall Section
1/2" = 1'-0"

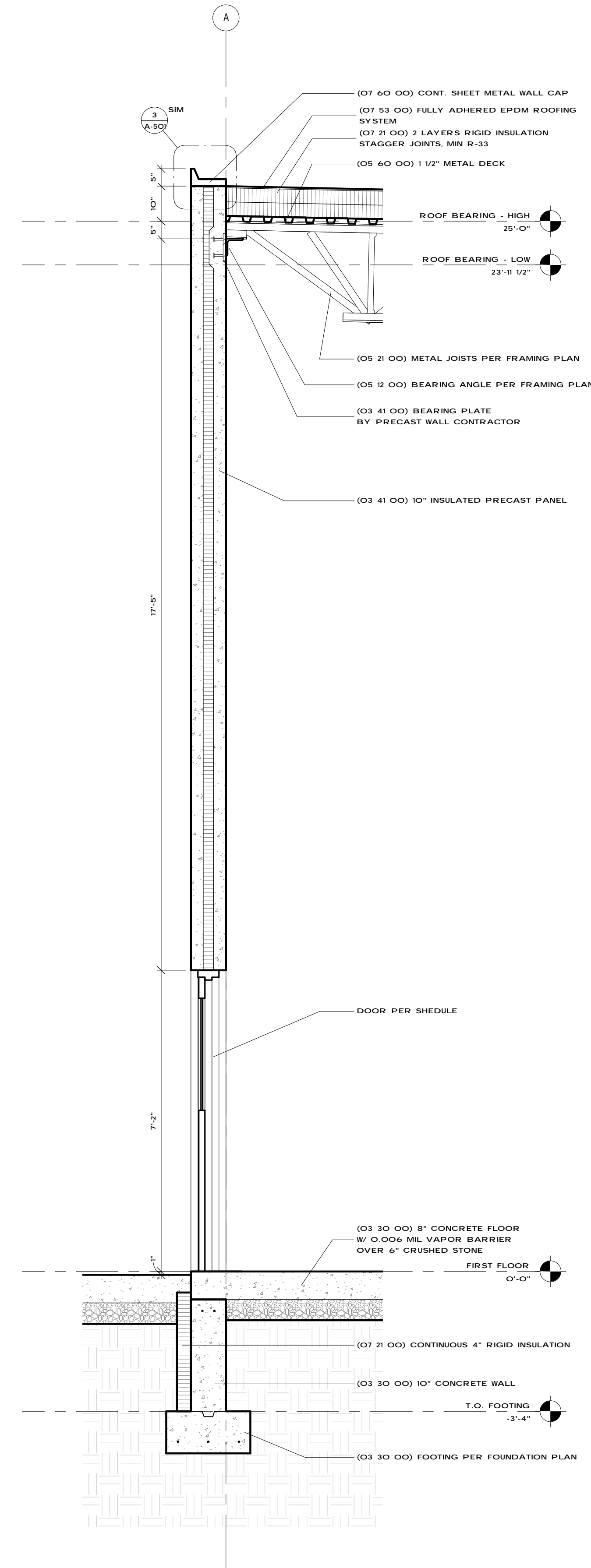

4 Wall Section
1/2" = 1'-0"

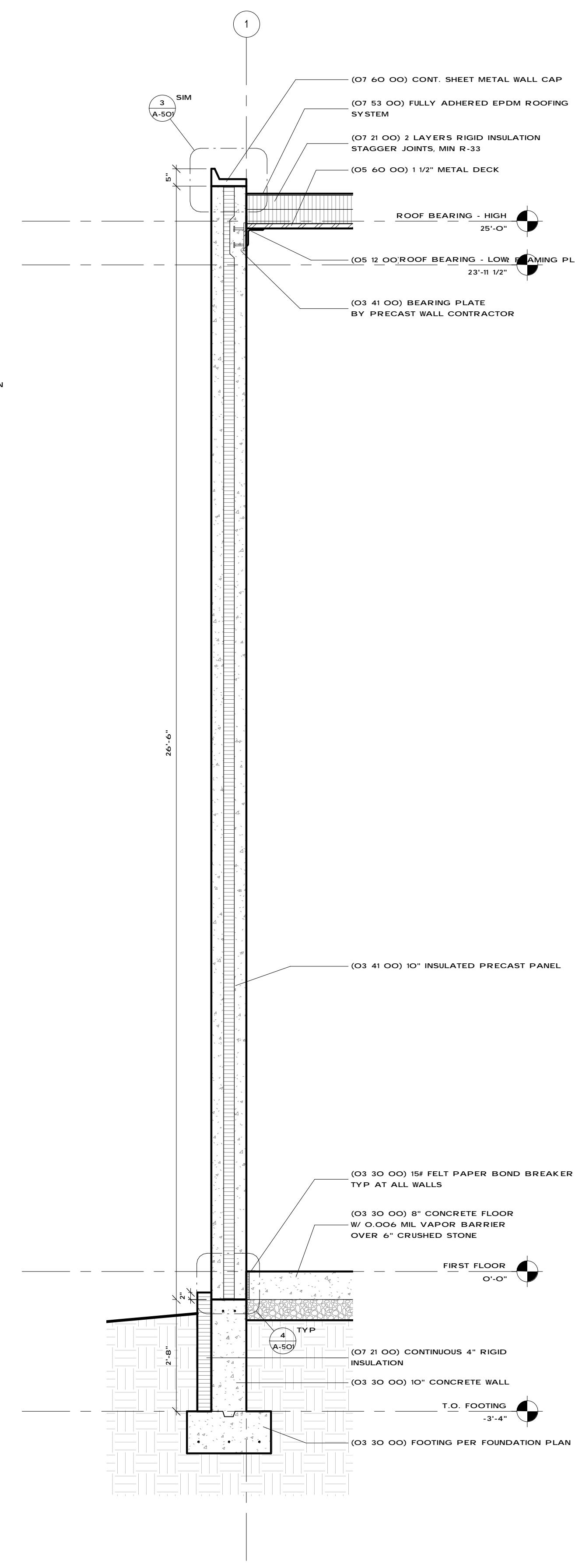

5 Wall Section
1/2" = 1'-0"

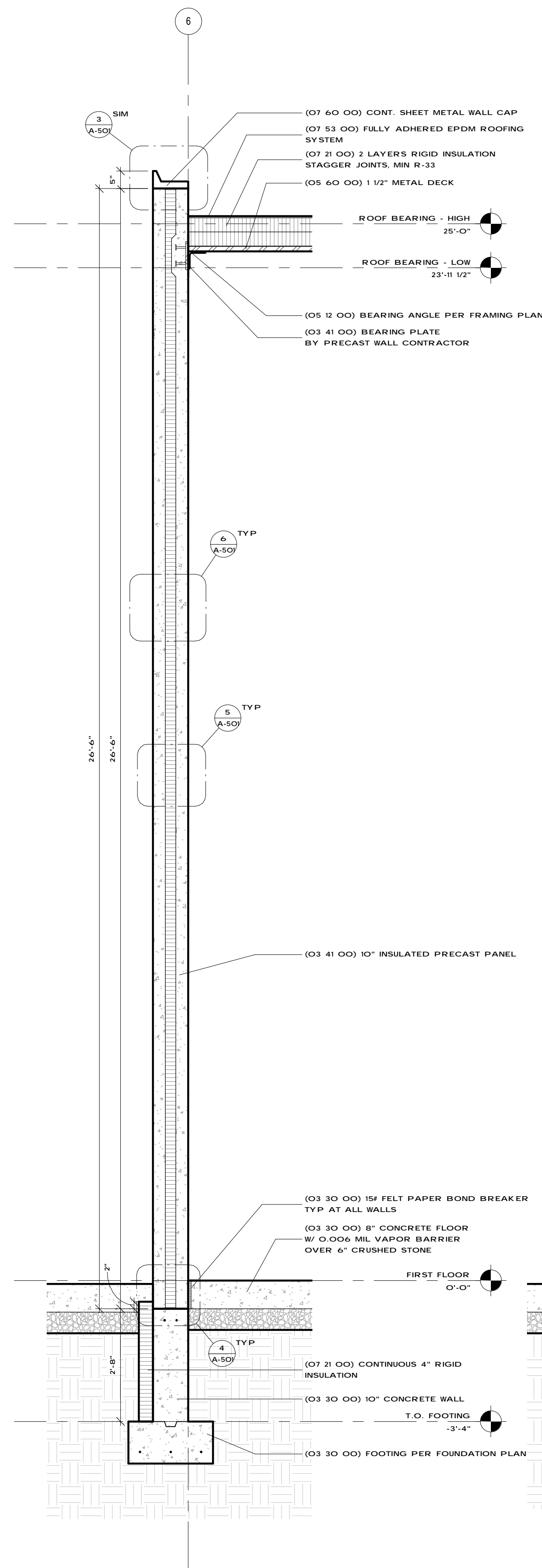

1 Wall Section
 1/2" = 1'-0"

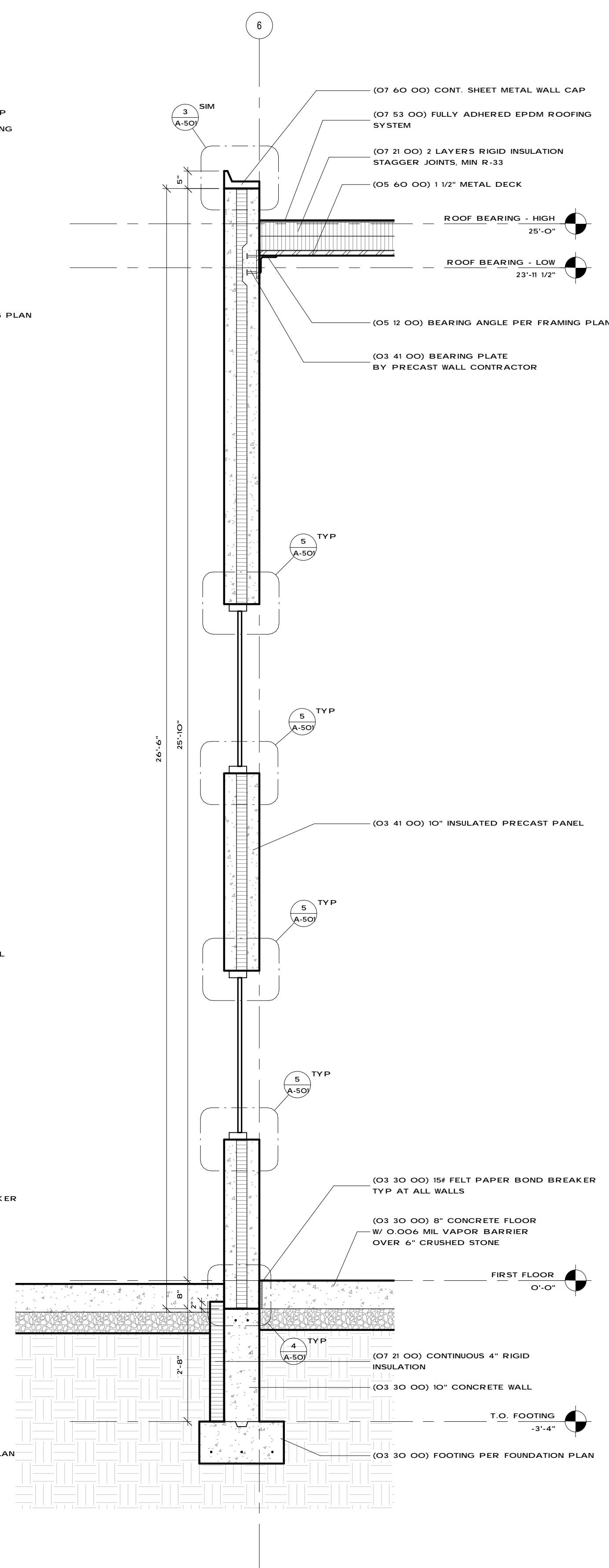

2 Wall Section
 1/2" = 1'-0"

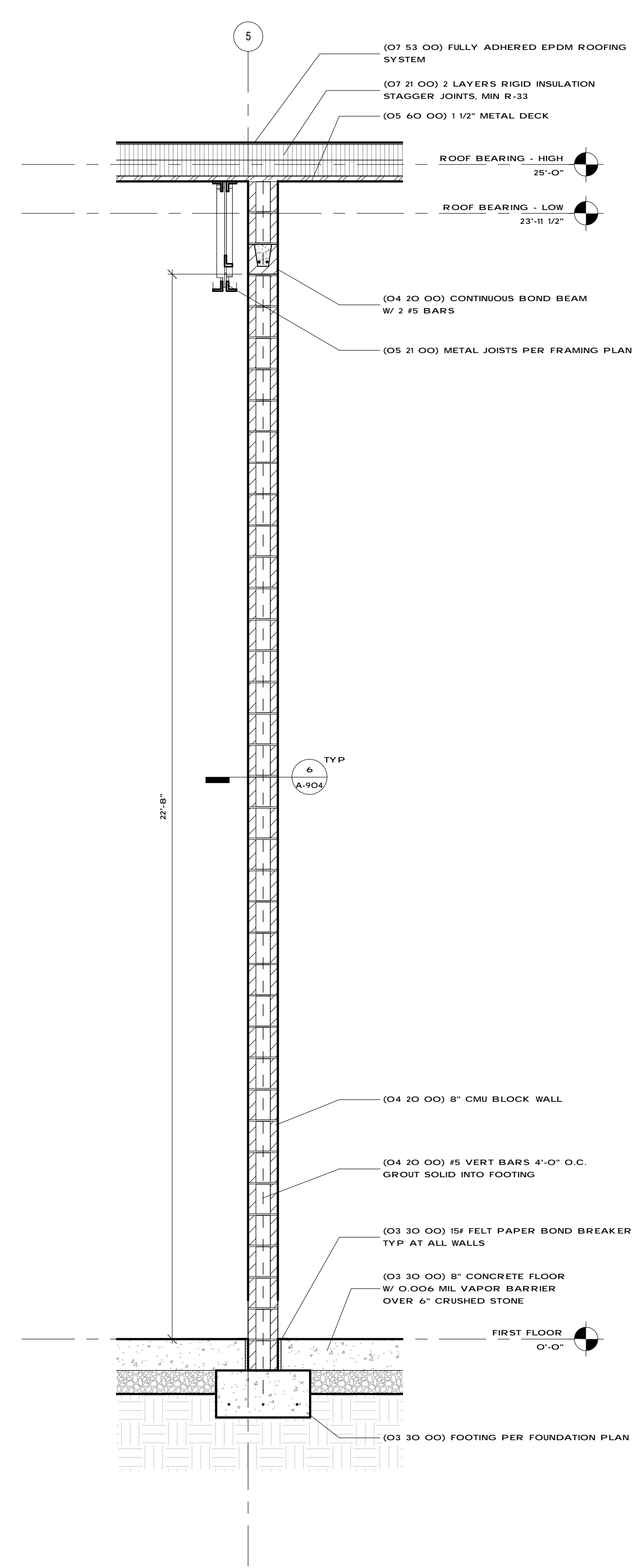

3 Wall Section
 1/2" = 1'-0"

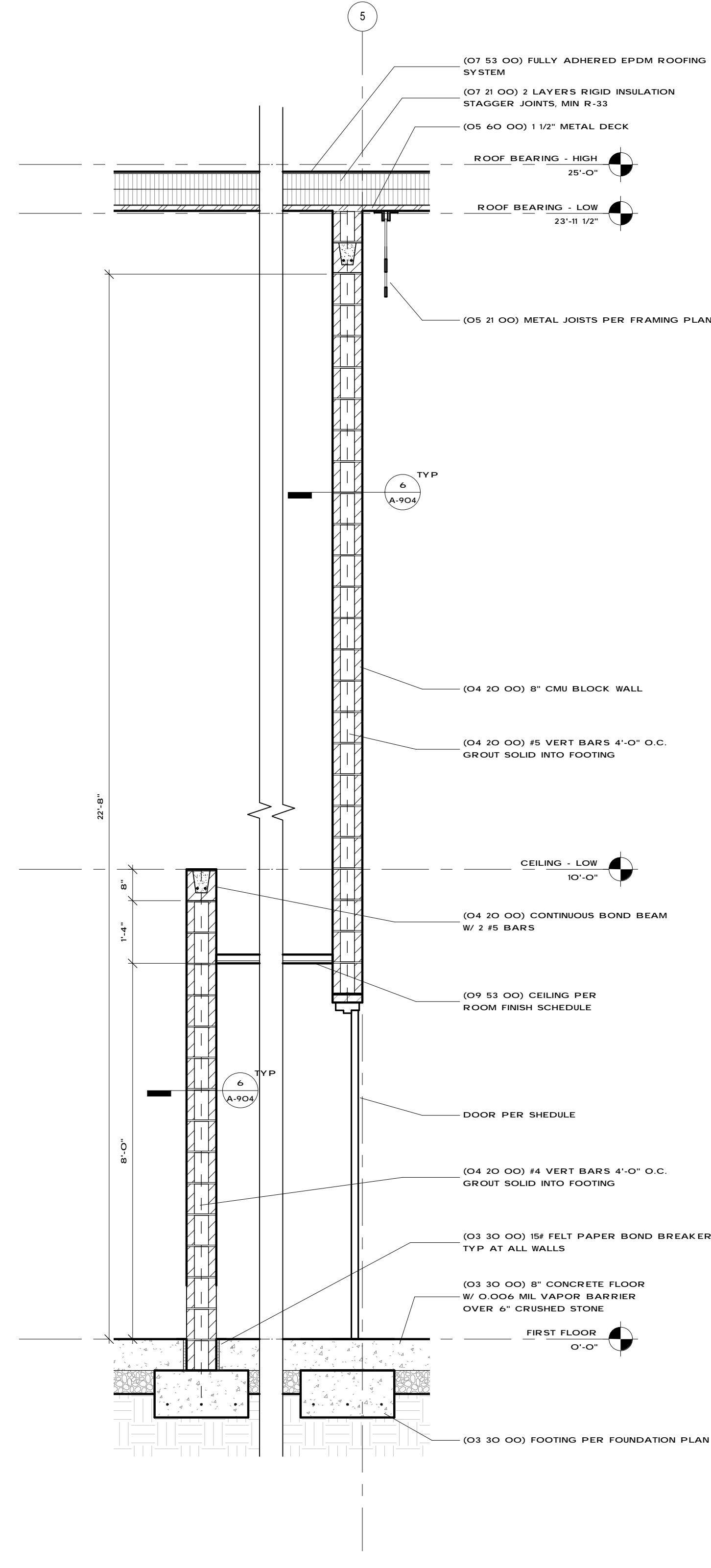

4 Wall Section
 1/2" = 1'-0"

12 Window Head - CMU
3" = 1'-0"

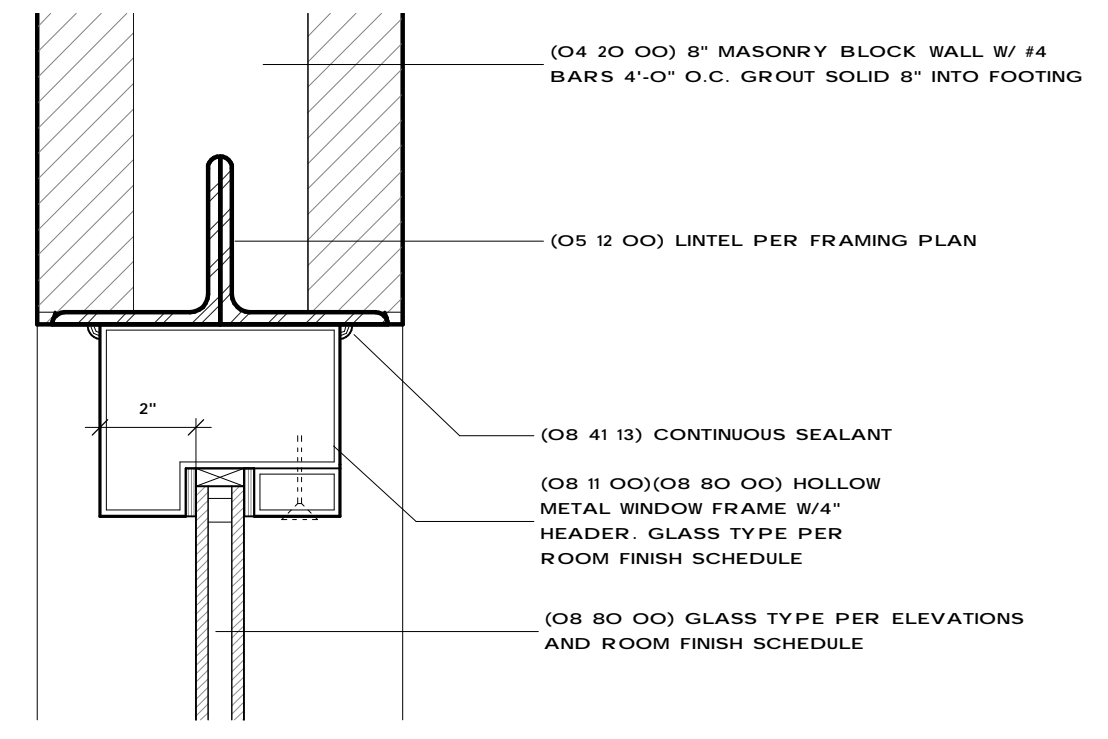

11 Window Sill - CMU
3" = 1'-0"

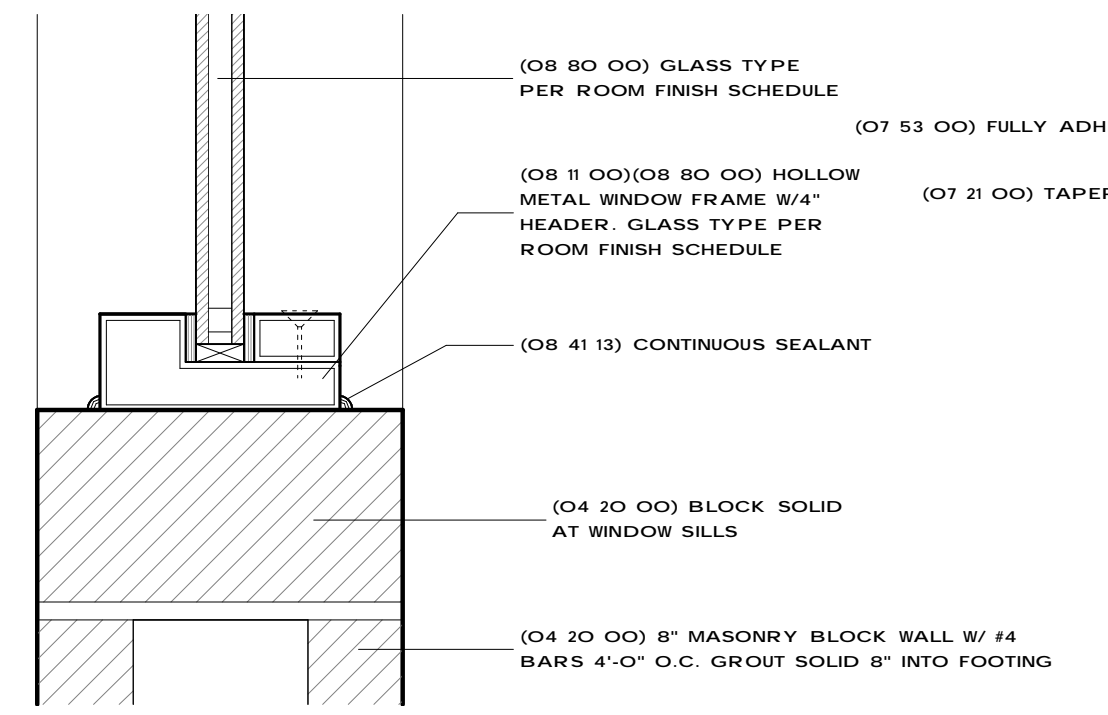

10 Mezzanine Bearing @ CMU
3" = 1'-0"

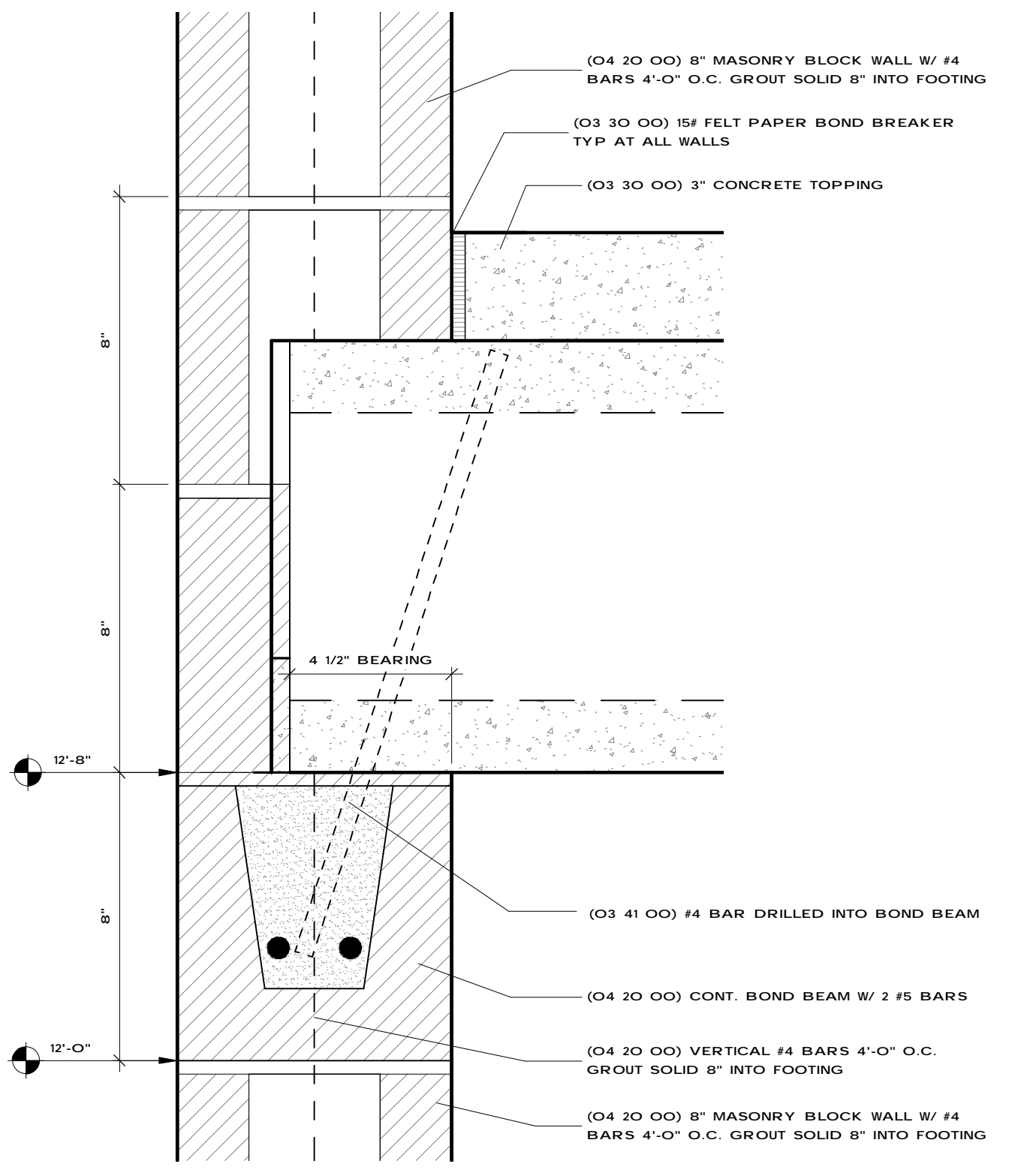

9 Callout of Offices - east wall
3" = 1'-0"

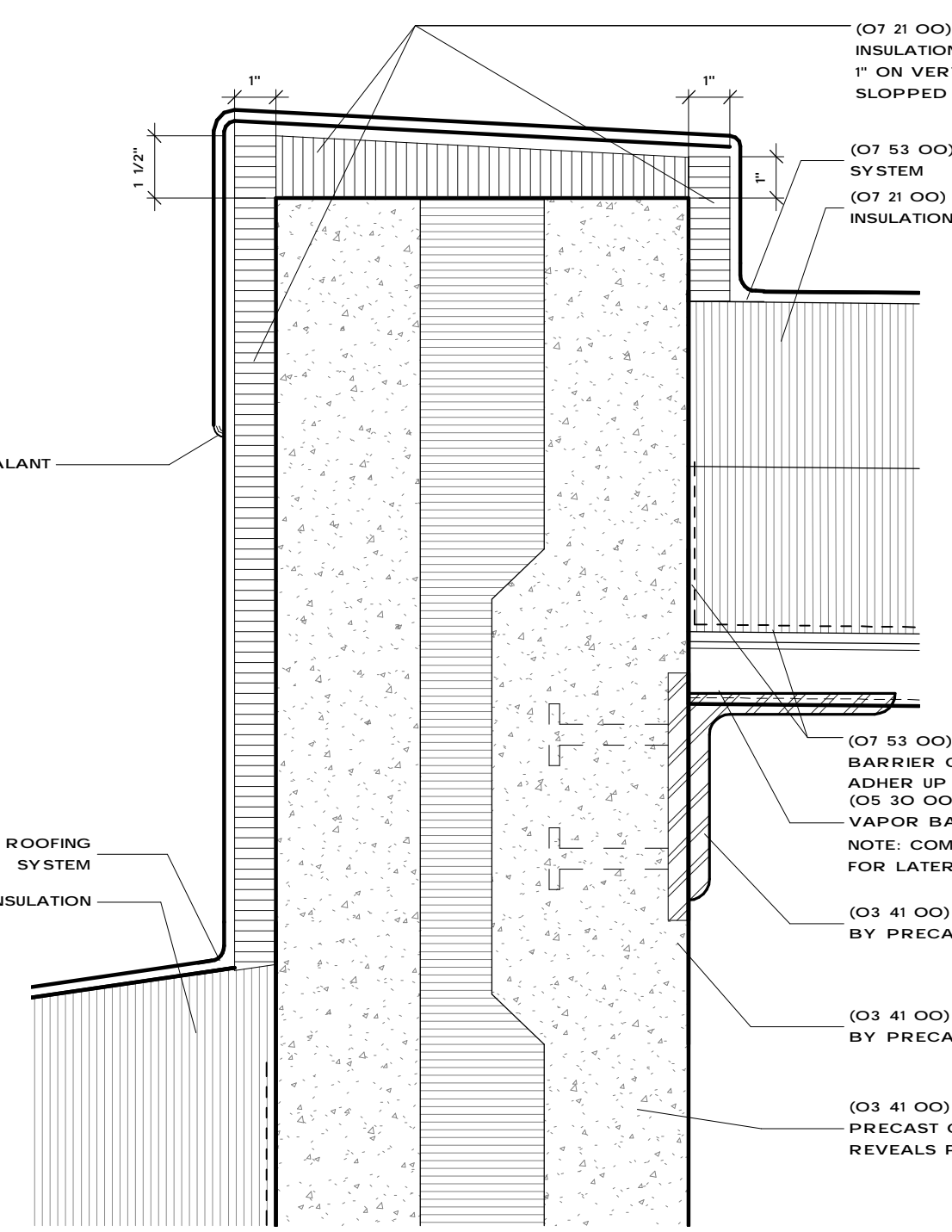

8 Roof Flashing
3" = 1'-0"

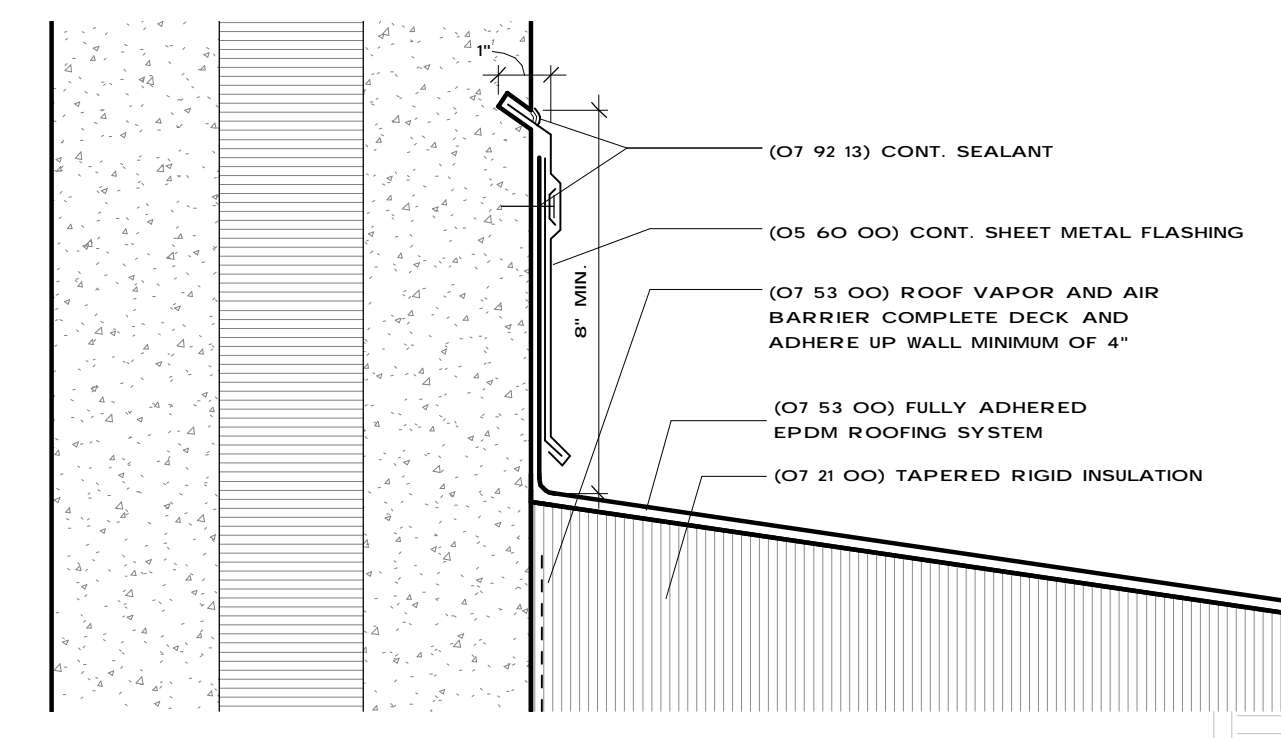

7 Reveal / Panel Joint
3" = 1'-0"

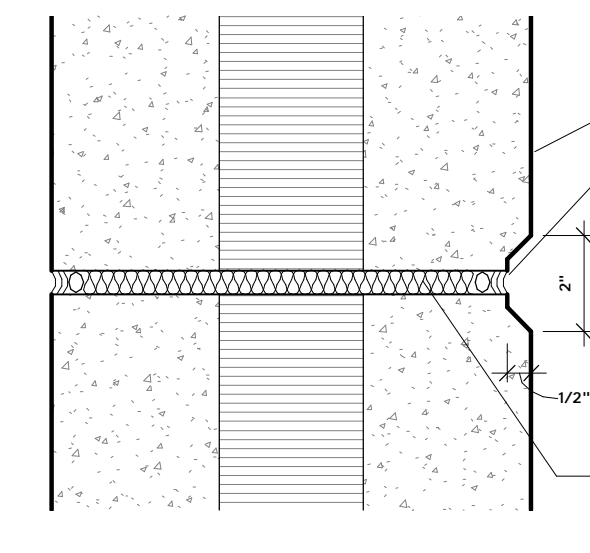

Typ. Window / Head Flashing

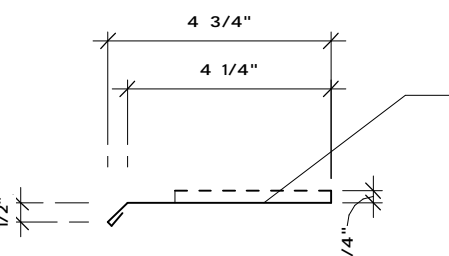

6 Window Head - Precast
3" = 1'-0"

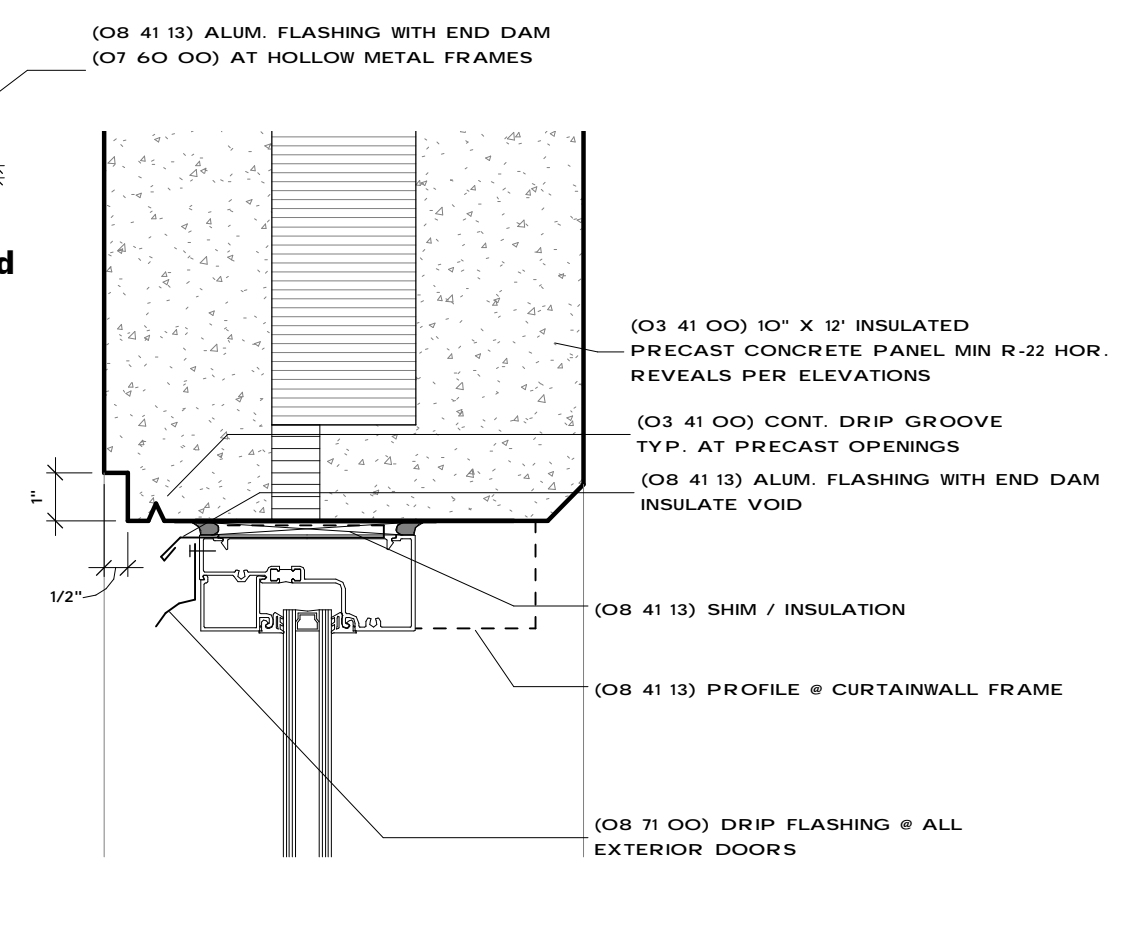

5 Window Sill - Precast
3" = 1'-0"

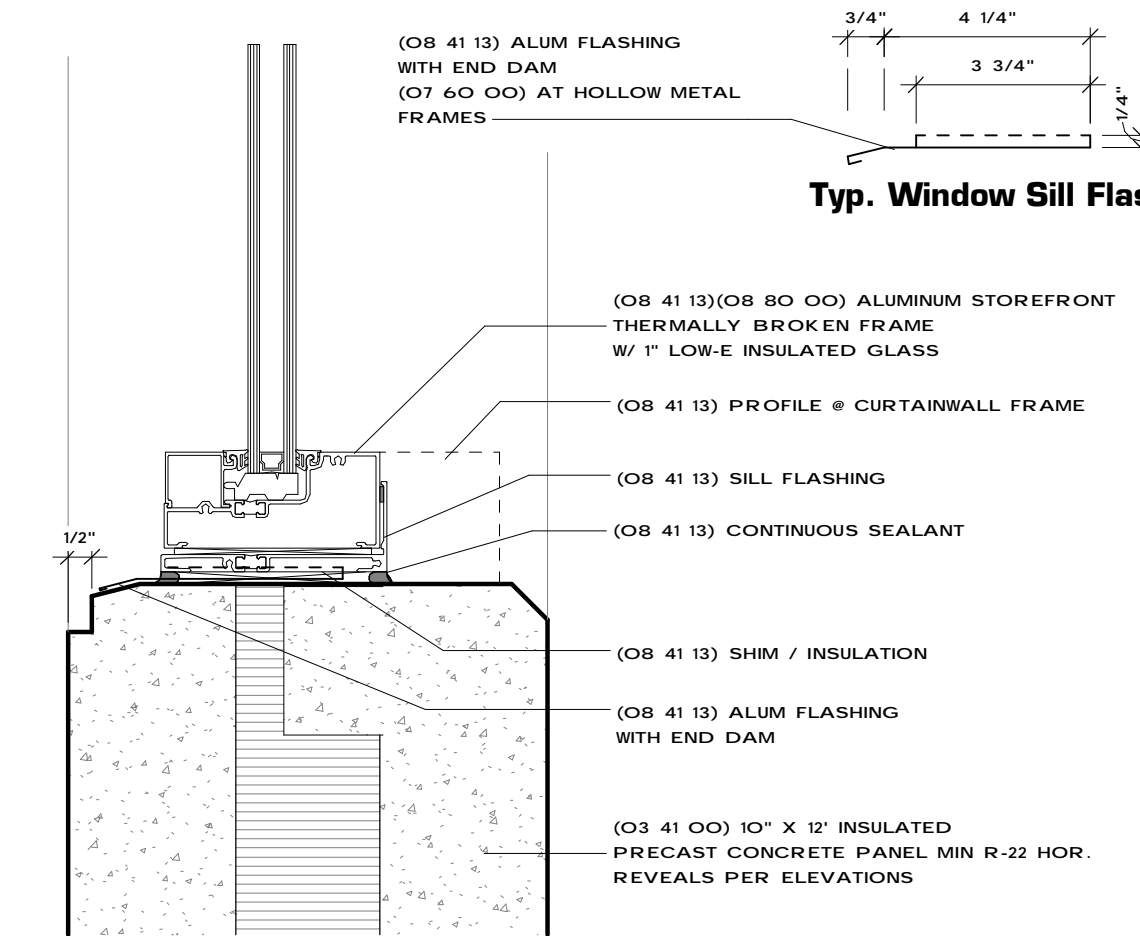

4 Precast Base
3" = 1'-0"

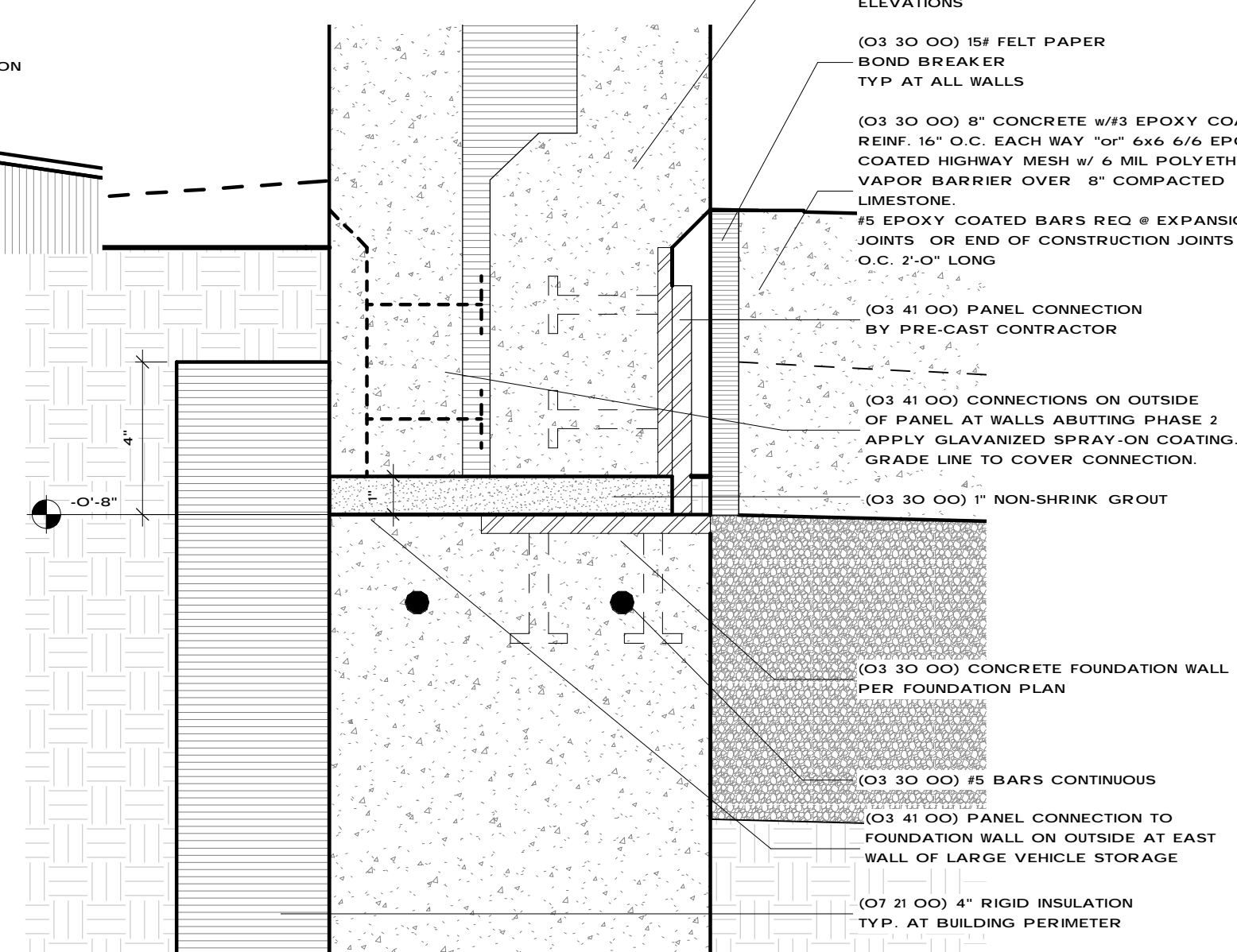

3 Wall Cap
3" = 1'-0"

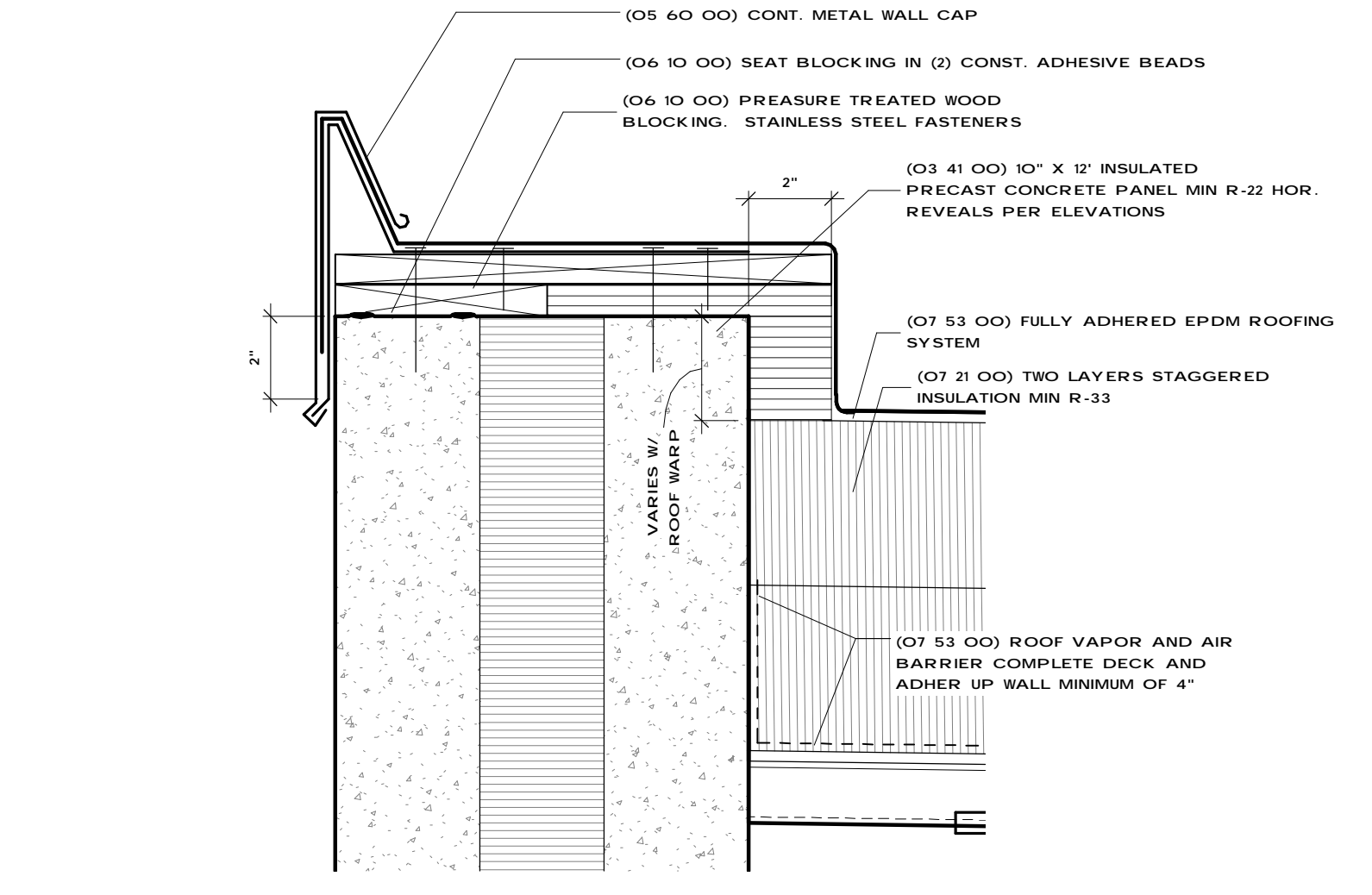

2 OH Door Head
3" = 1'-0"

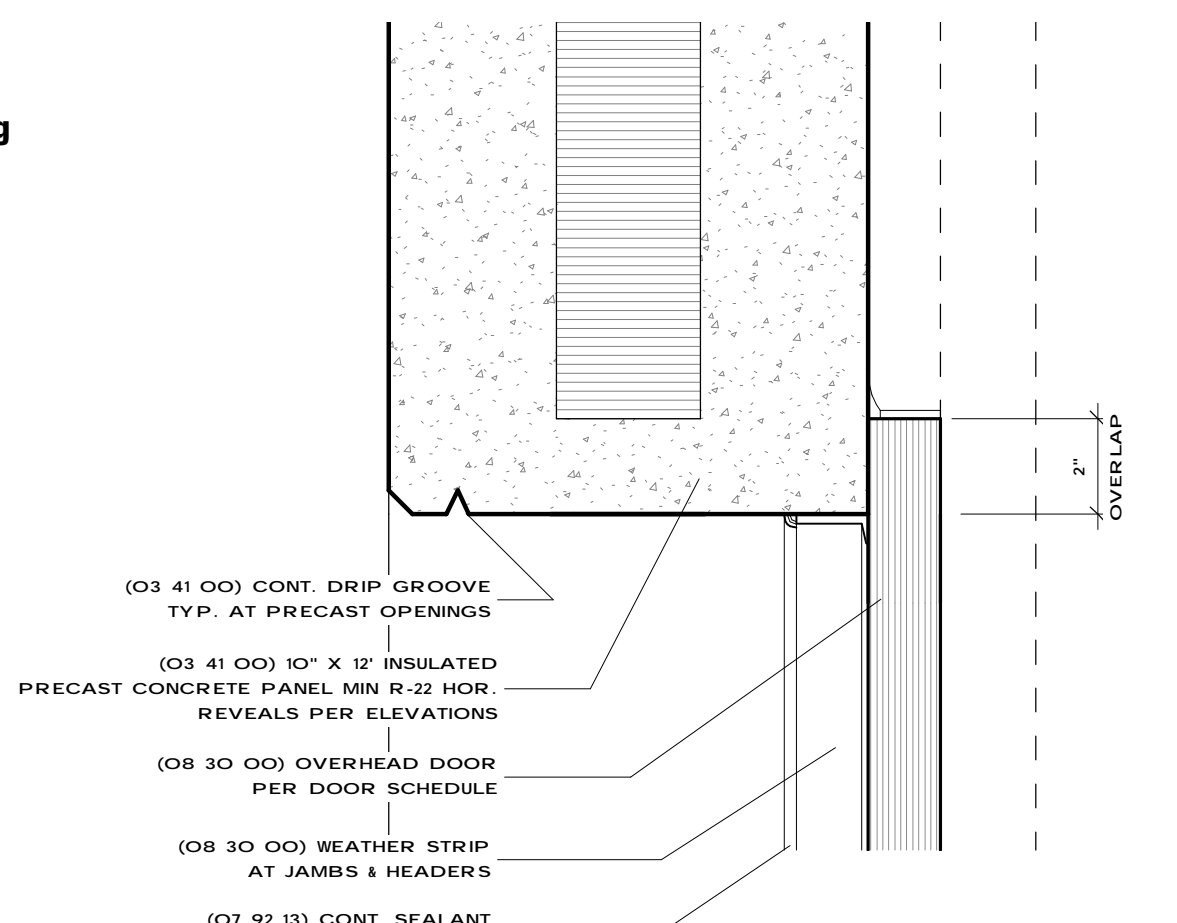

1 OH Door Threshold
3" = 1'-0"

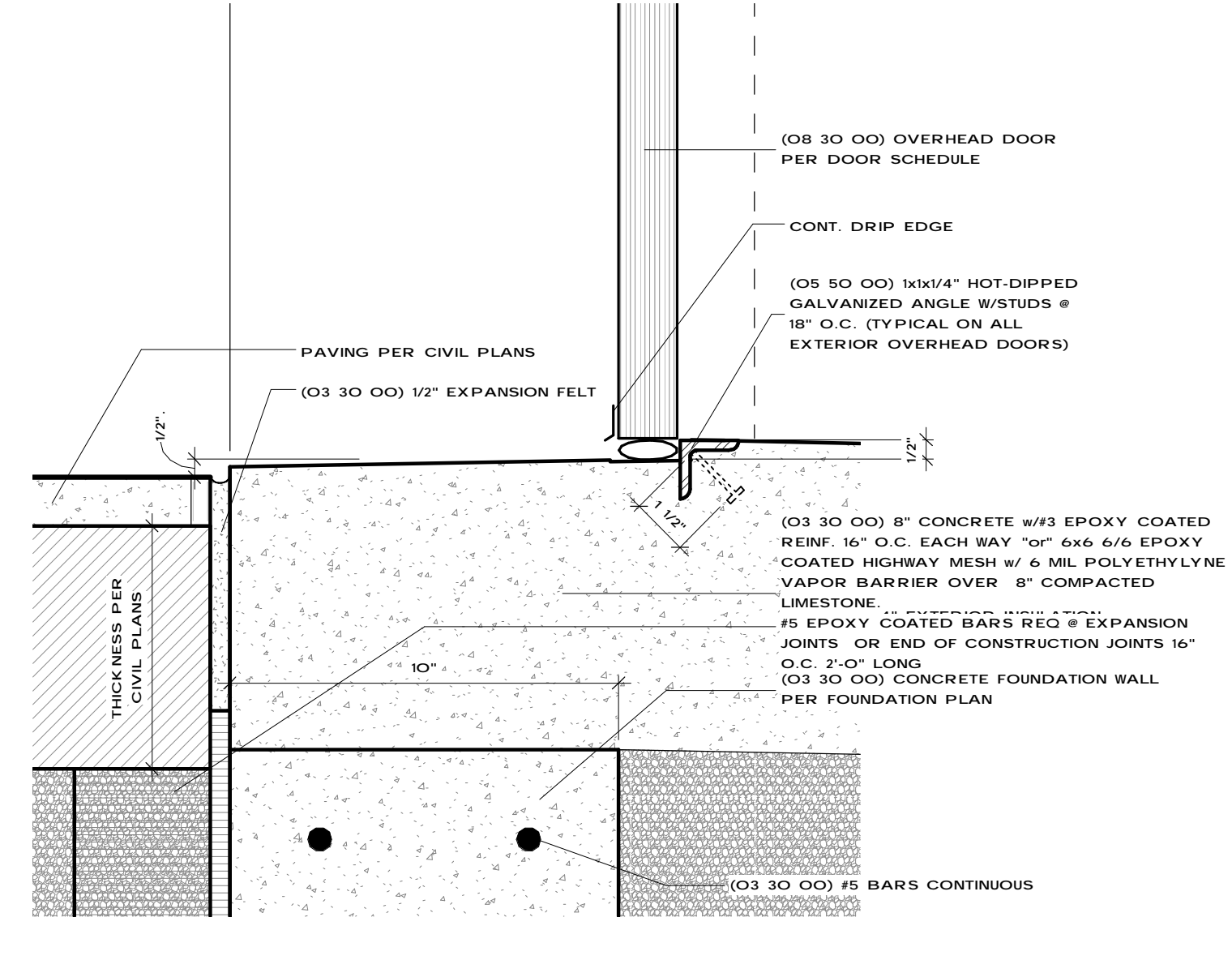

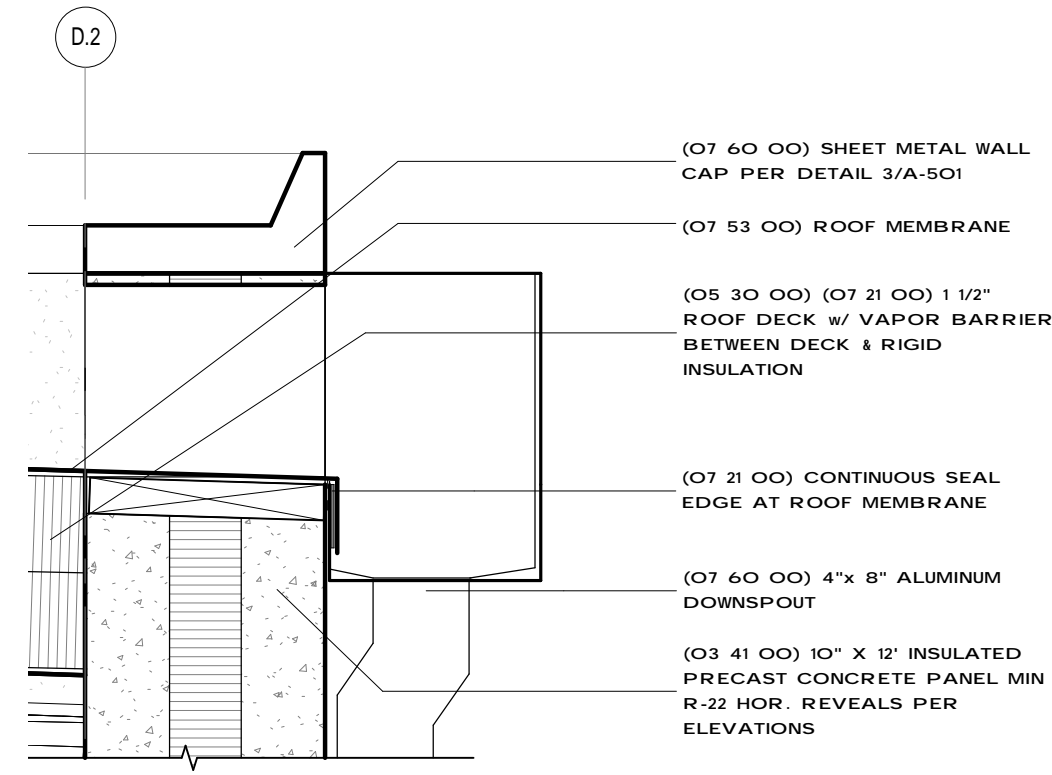

1 Scupper Drain Box Detail
1 1/2" = 1'-0"

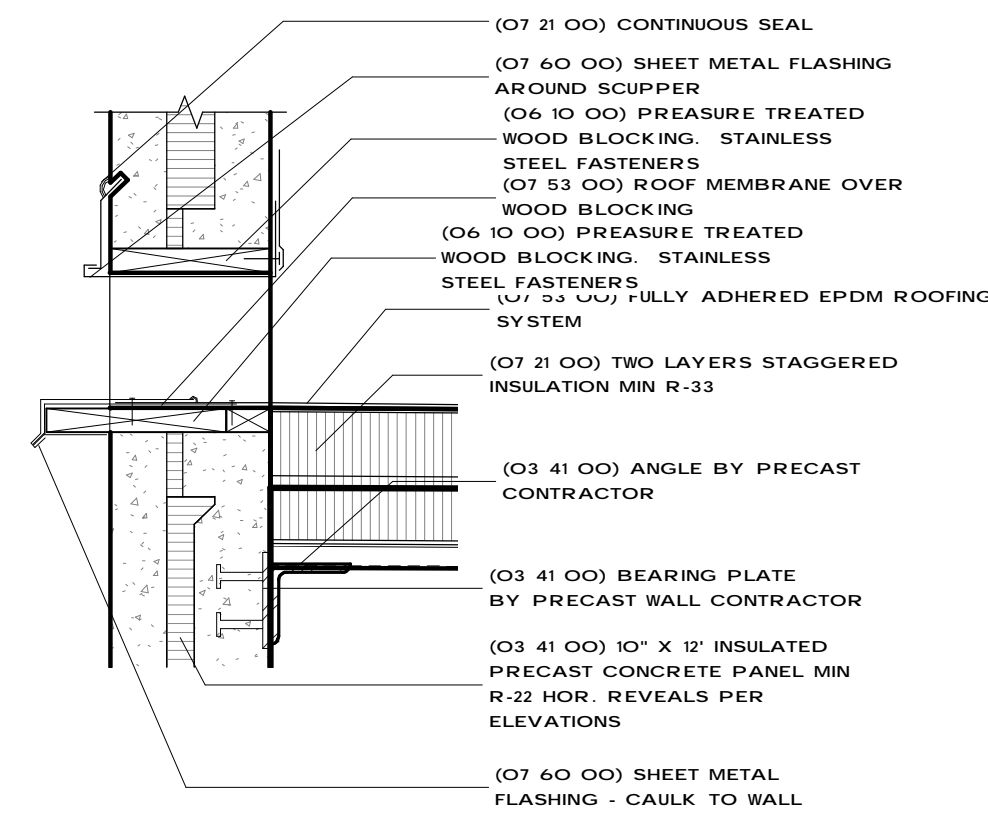

2 Scupper Detail - Section
1" = 1'-0"

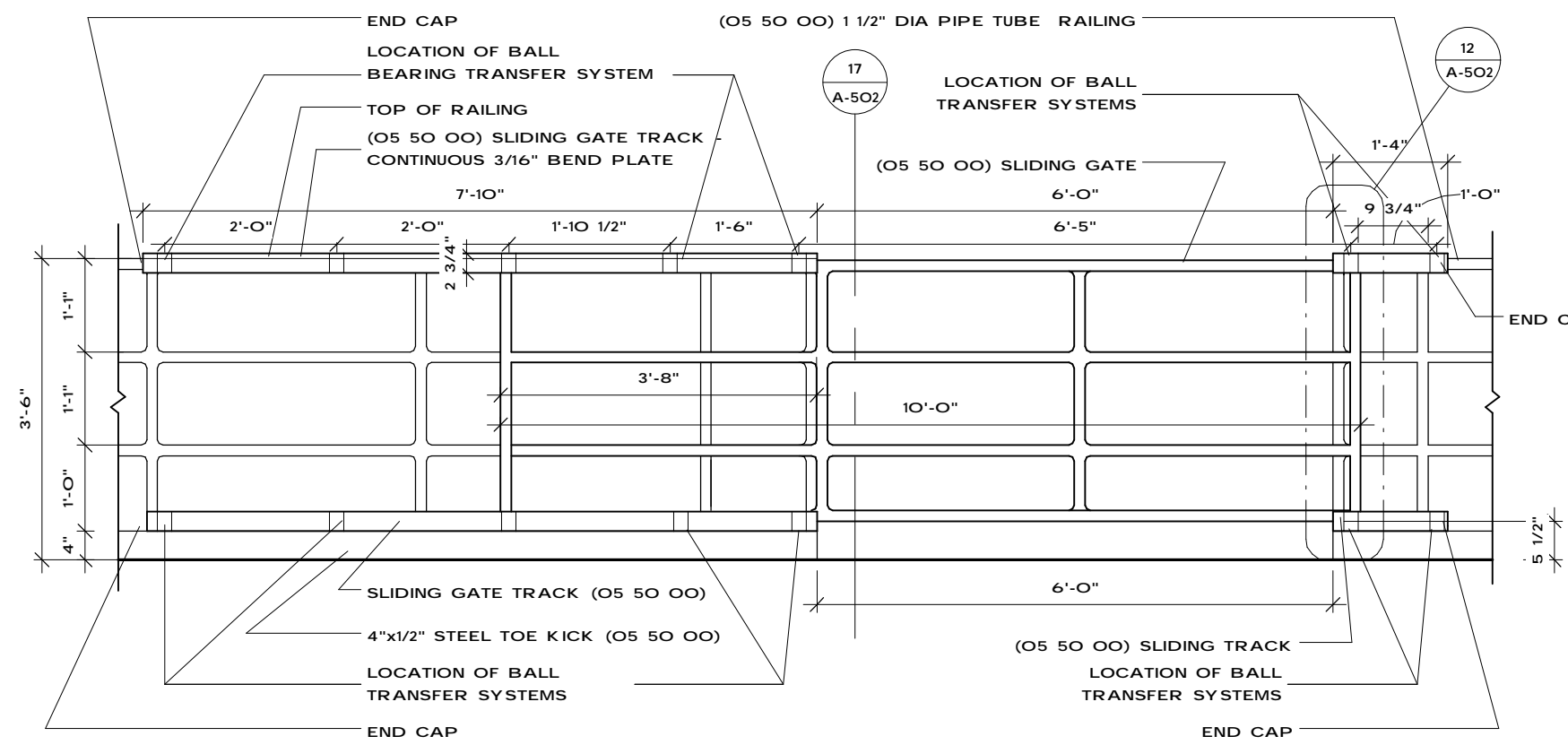

3 Mezzanine Sliding Gate - Typ. Elevation
1/2" = 1'-0"

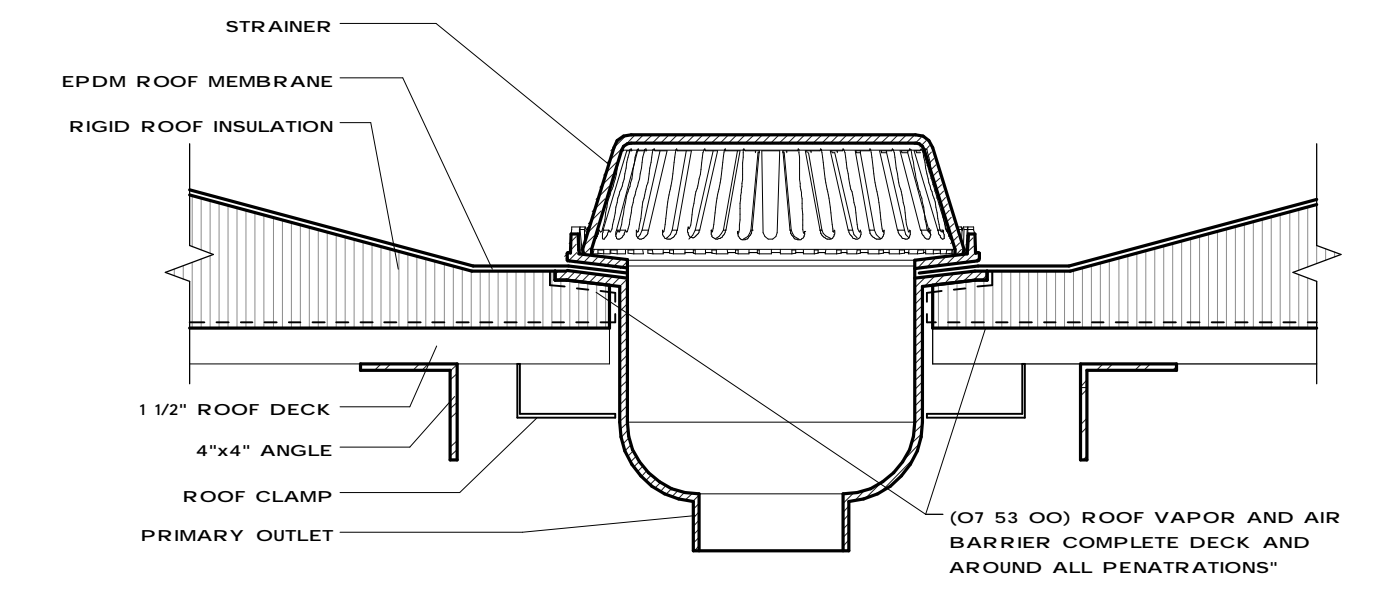

4 Roof Drain
1 1/2" = 1'-0"

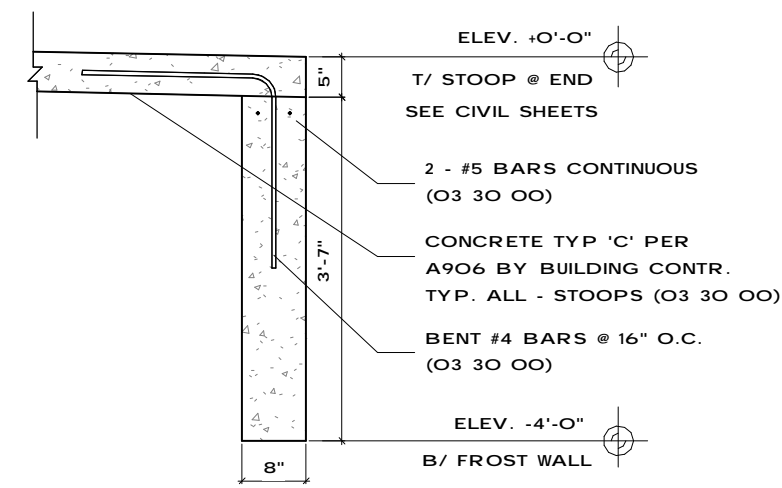

5 Stoop Frost Wall
1/2" = 1'-0"

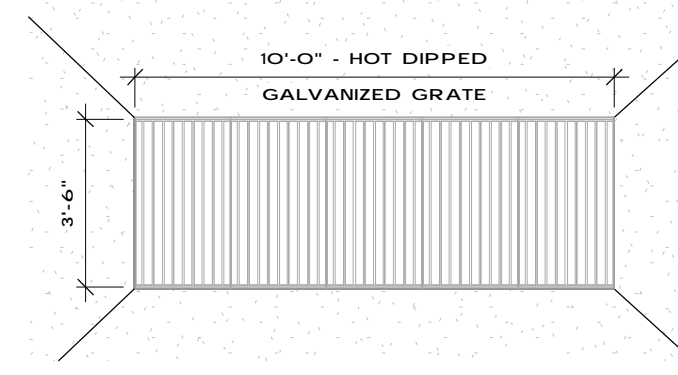

6 Large Trench Drain Plan
1/4" = 1'-0"

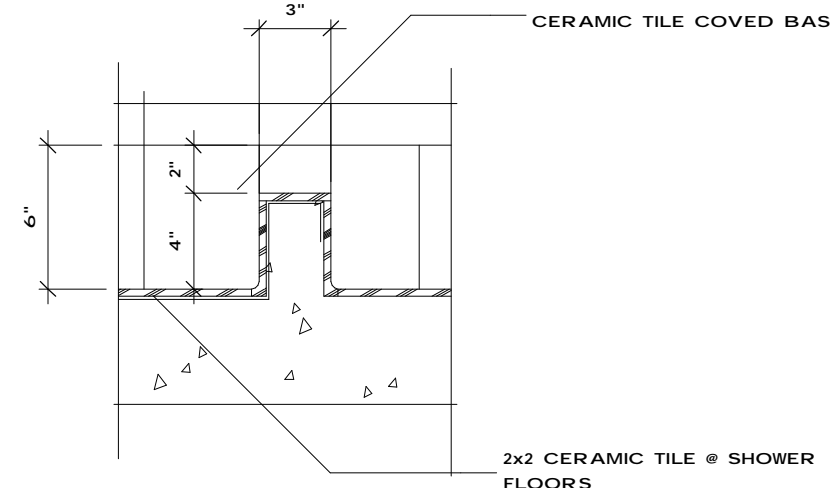

7 Detail @ Shower Floor
1 1/2" = 1'-0"

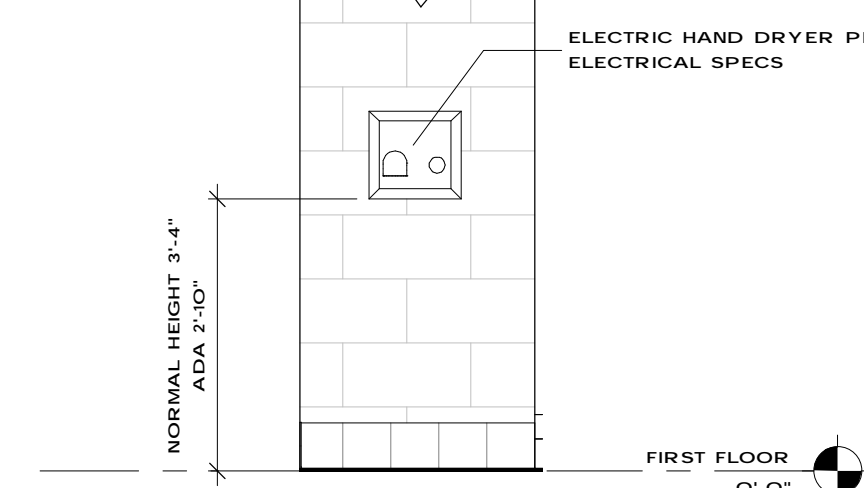

8 Electric Hand Dryer Elev
1/2" = 1'-0"

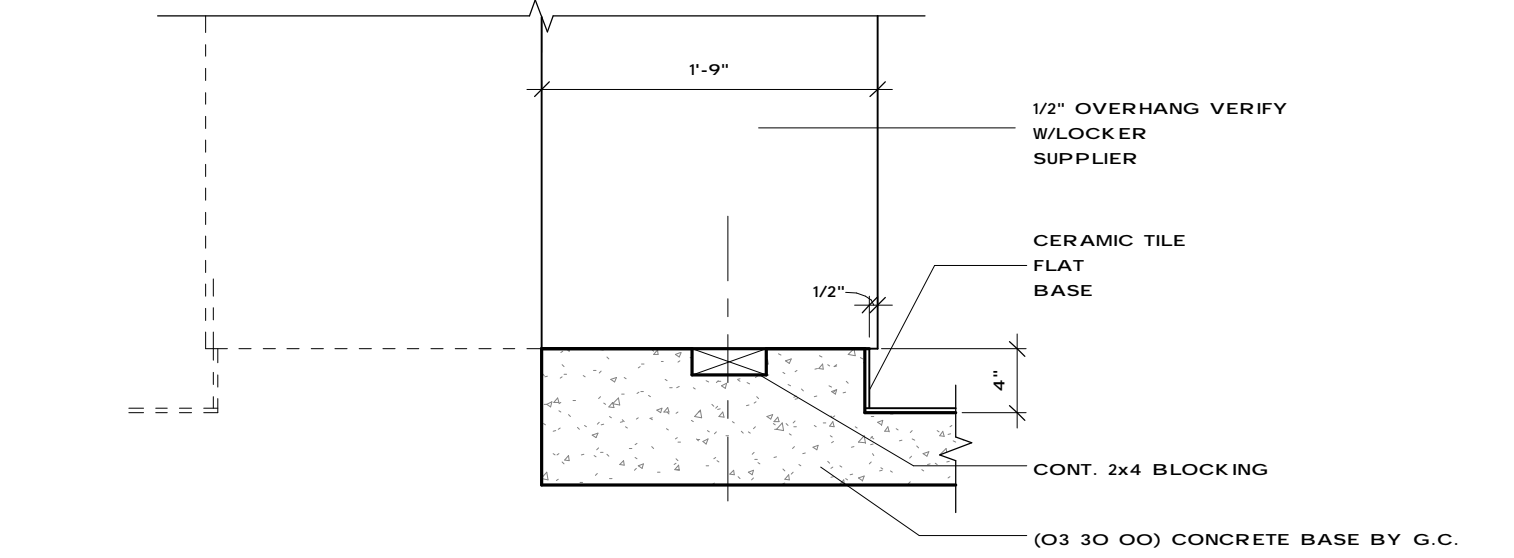

9 Locker Base
1" = 1'-0"

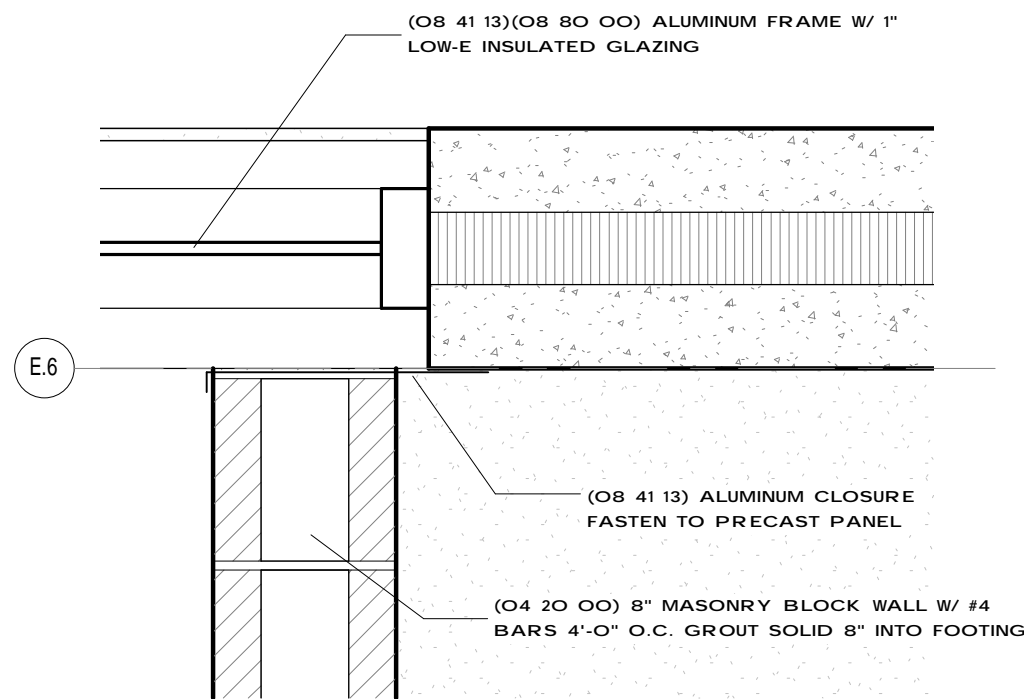

10 Masonry Wall Closure @ Window
1 1/2" = 1'-0"

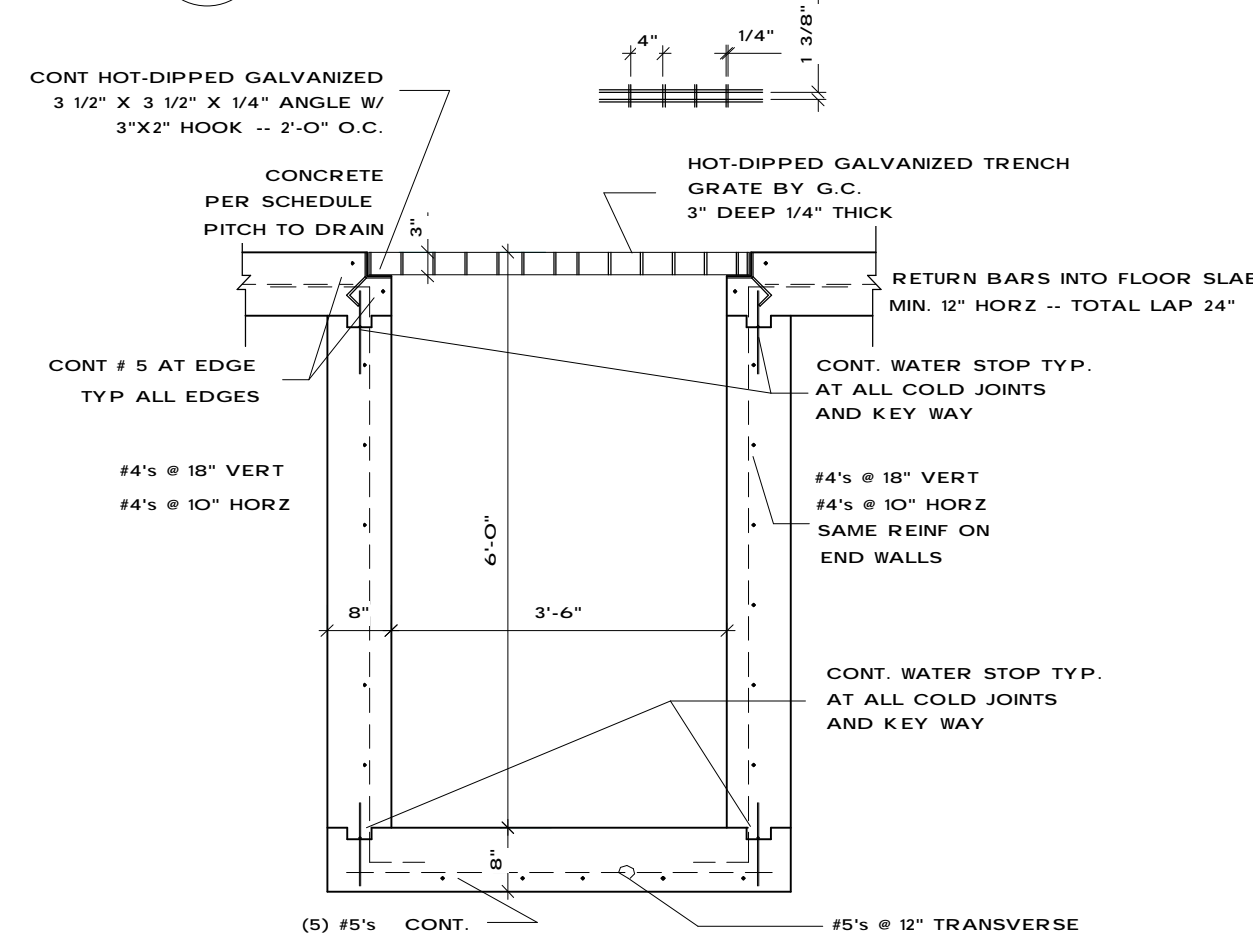

11 Trench Drain - Large
1/2" = 1'-0"

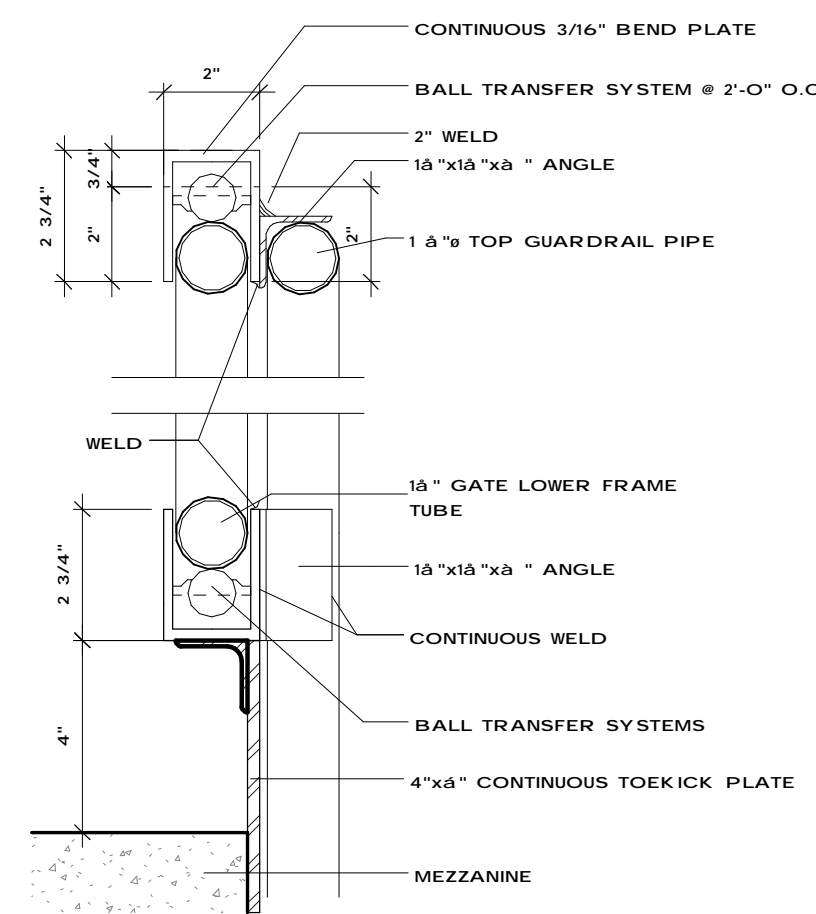

12 Sliding Gate Detail
3" = 1'-0"

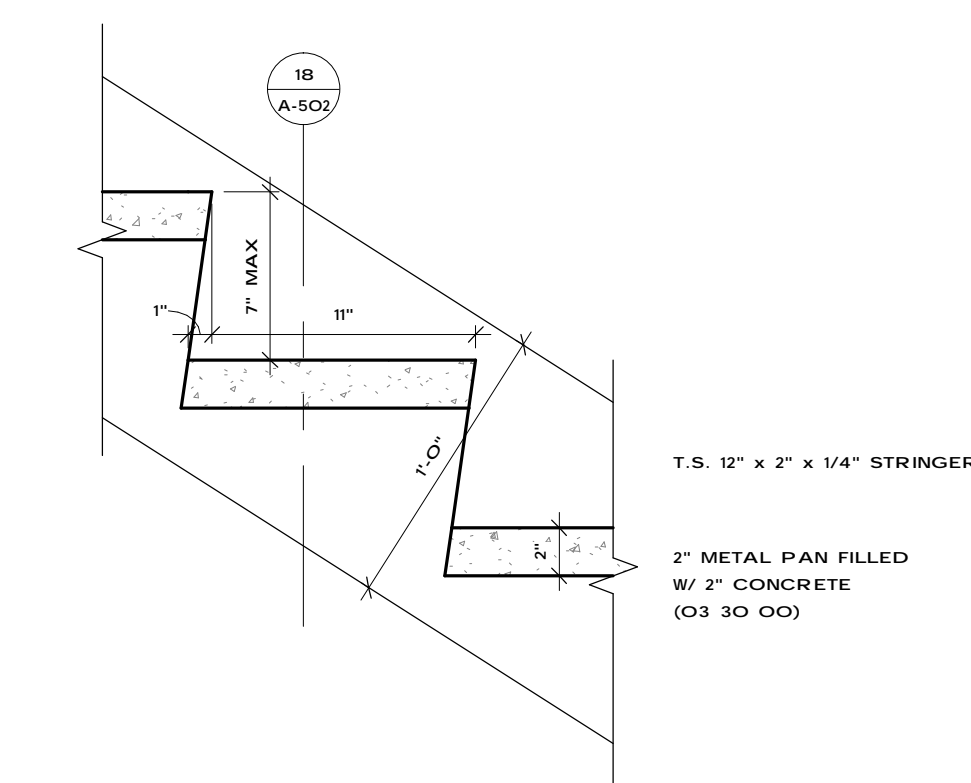

13 Stair Typ.
1 1/2" = 1'-0"

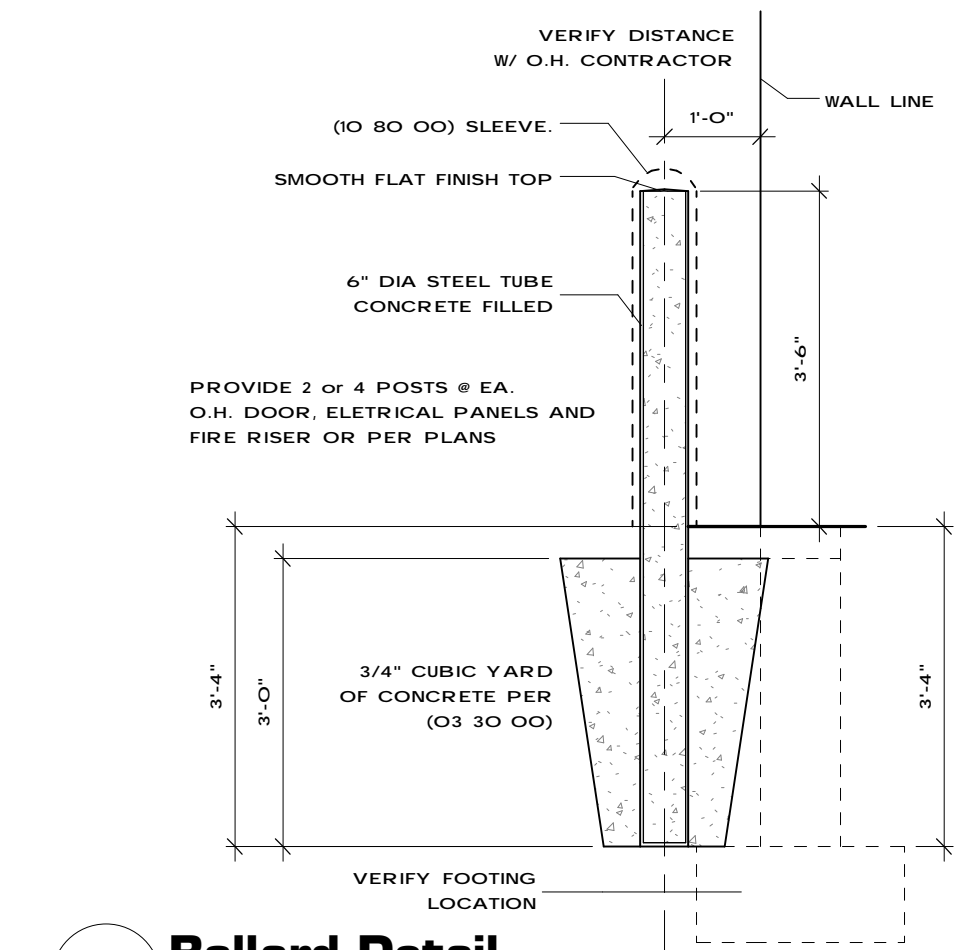

14 Bollard Detail
1/2" = 1'-0"

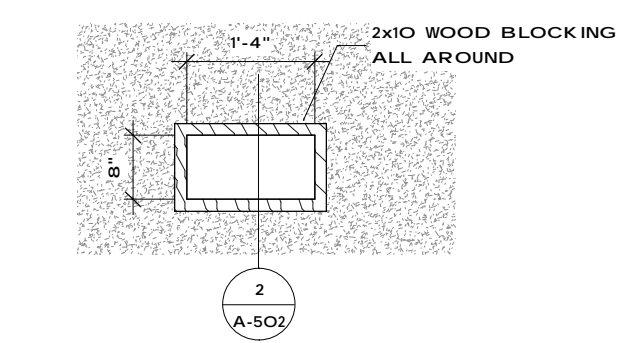

15 Scupper Detail - Elev
1/2" = 1'-0"

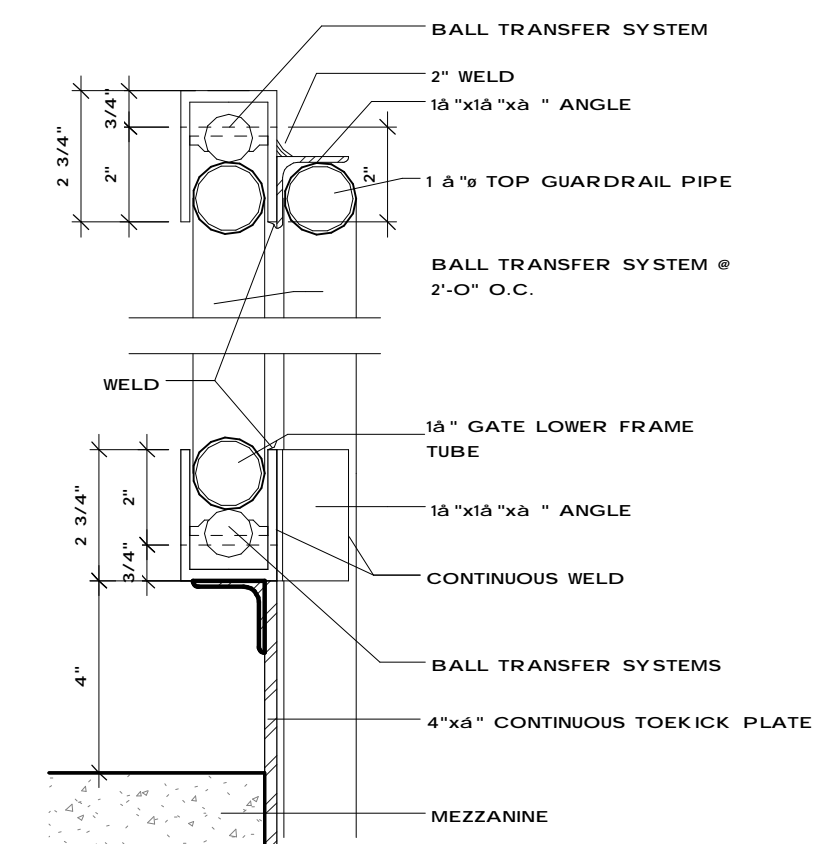

16 Sliding Gate Detail
3" = 1'-0"

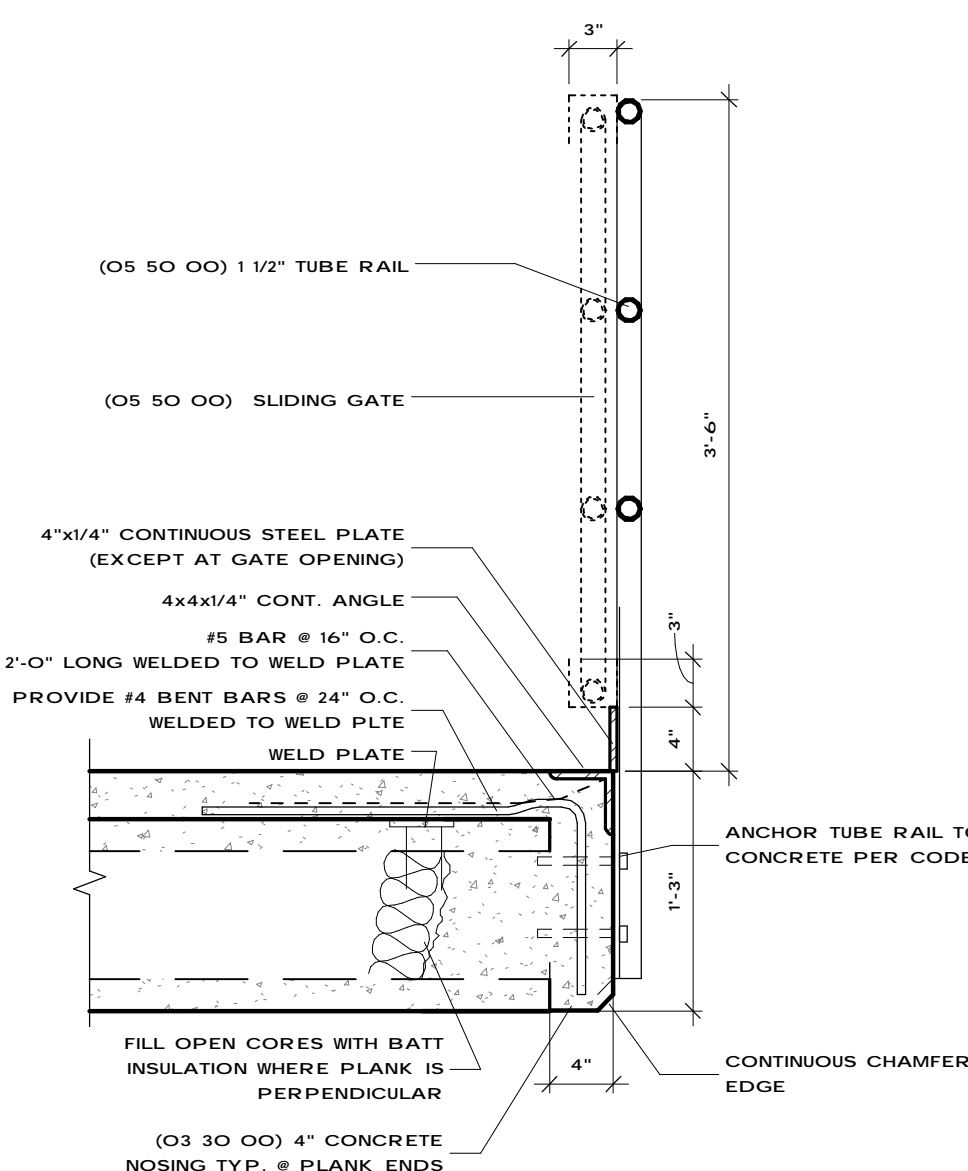

17 Mezzanine Gate Section
1" = 1'-0"

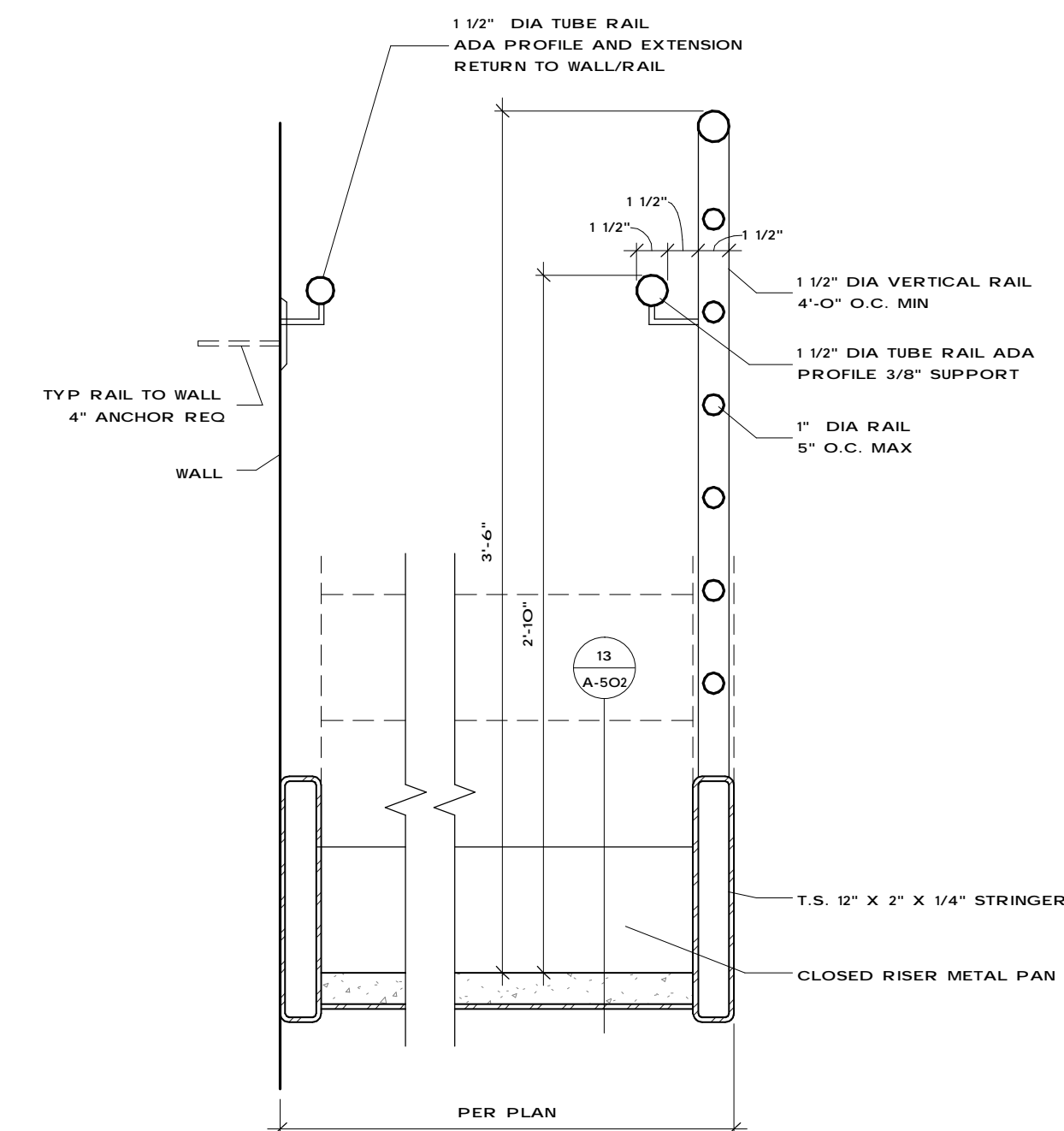

18 Pipe Rail Stair - Egress
1 1/2" = 1'-0"

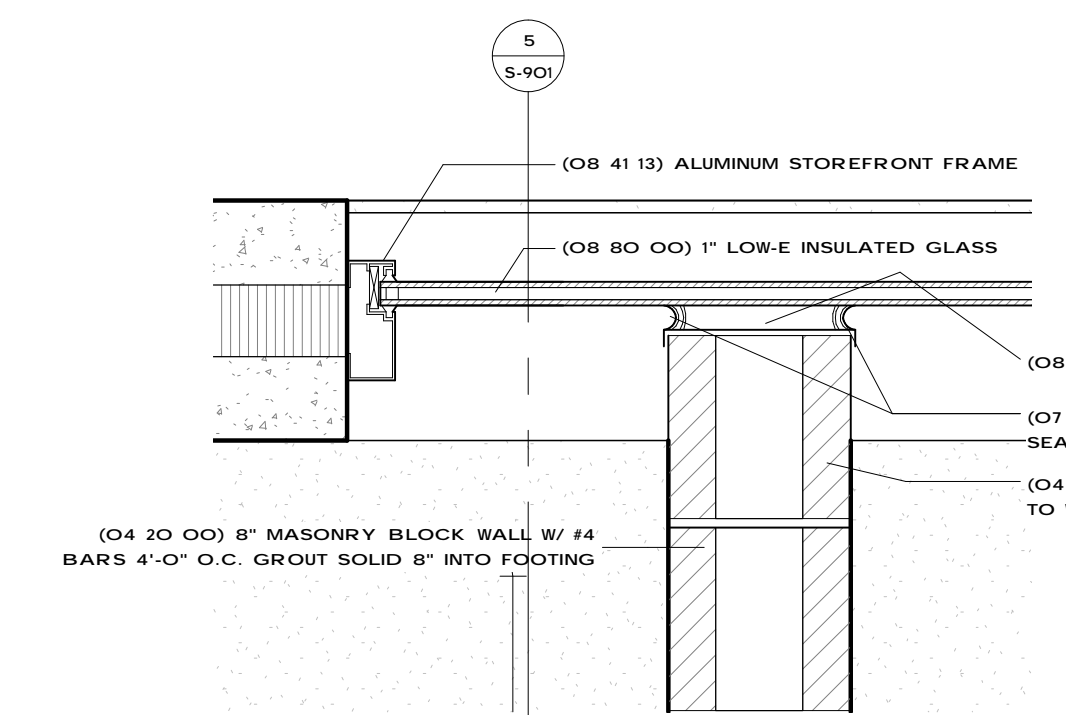

19 Fire Barrier Joint @ Window
1 1/2" = 1'-0"

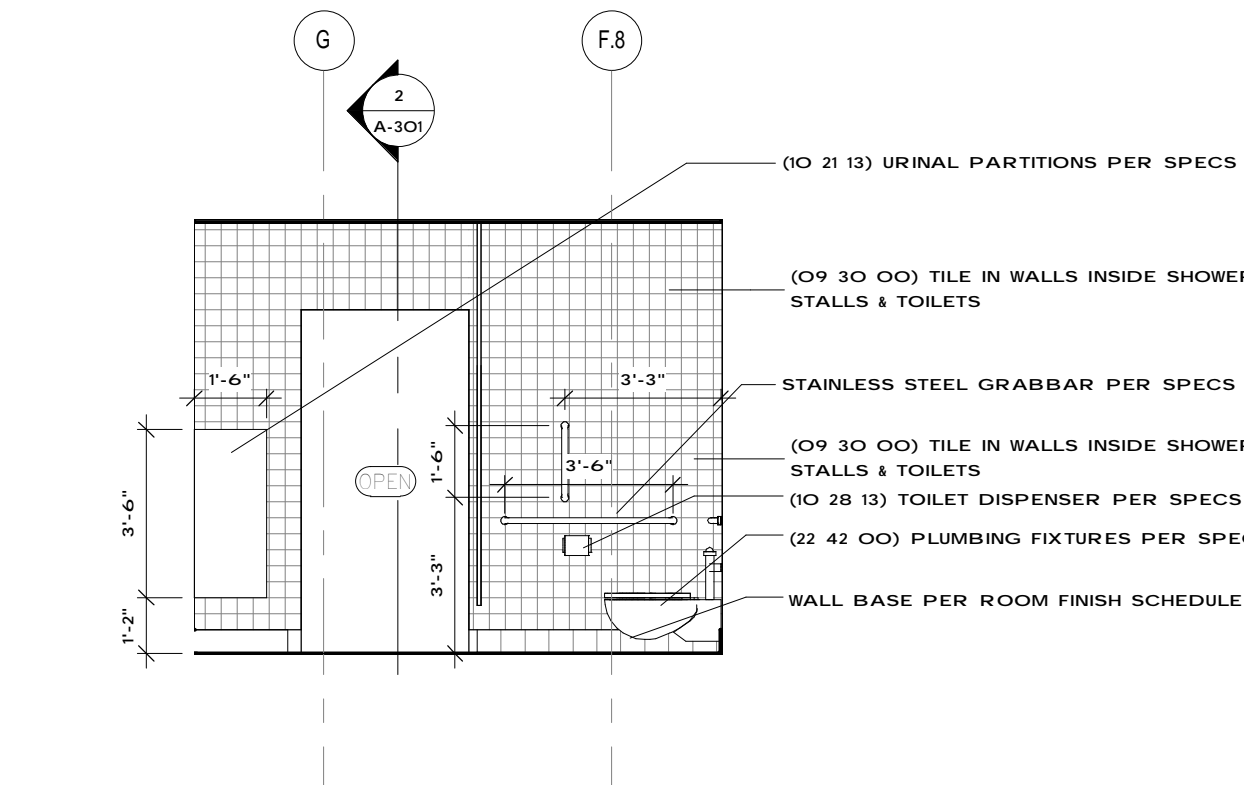

1 Men's Toilets 135-C - ADA stall West Wall
1/4" = 1'-0"

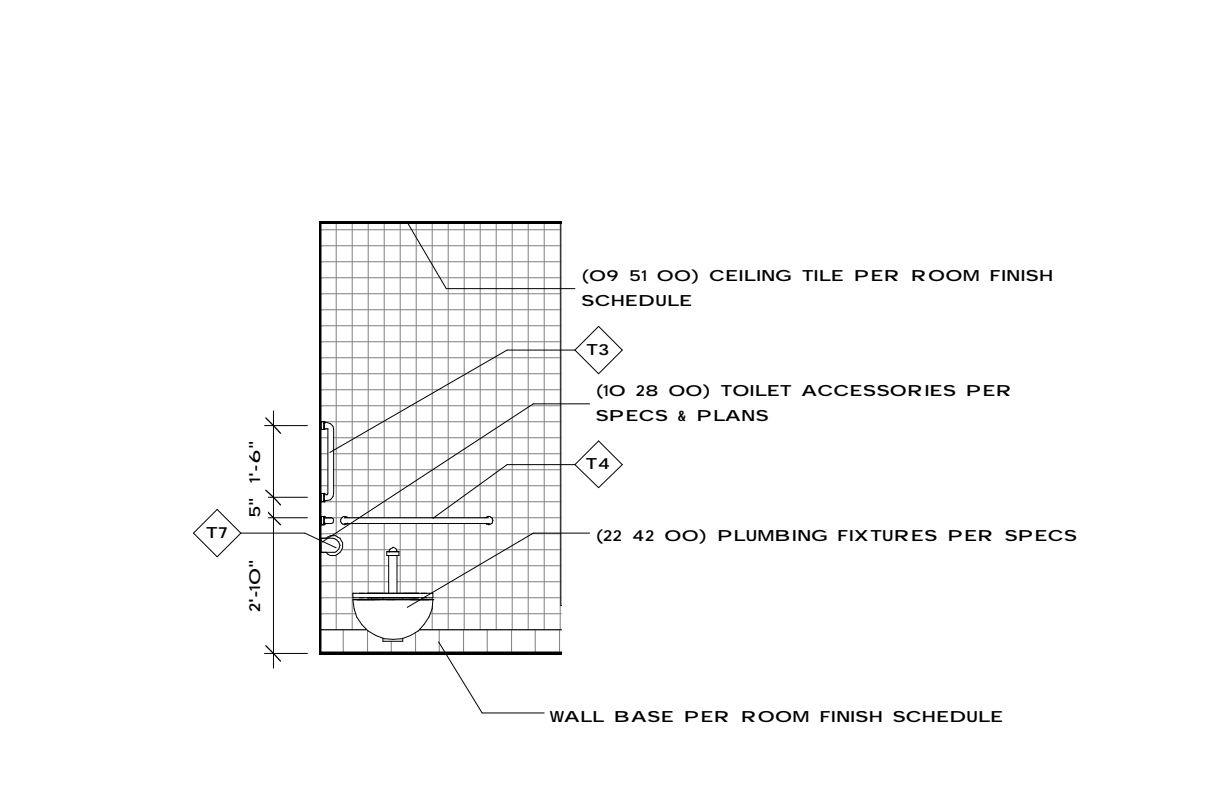

2 Men's Toilets 135-C - ADA Stall North Wall
1/4" = 1'-0"

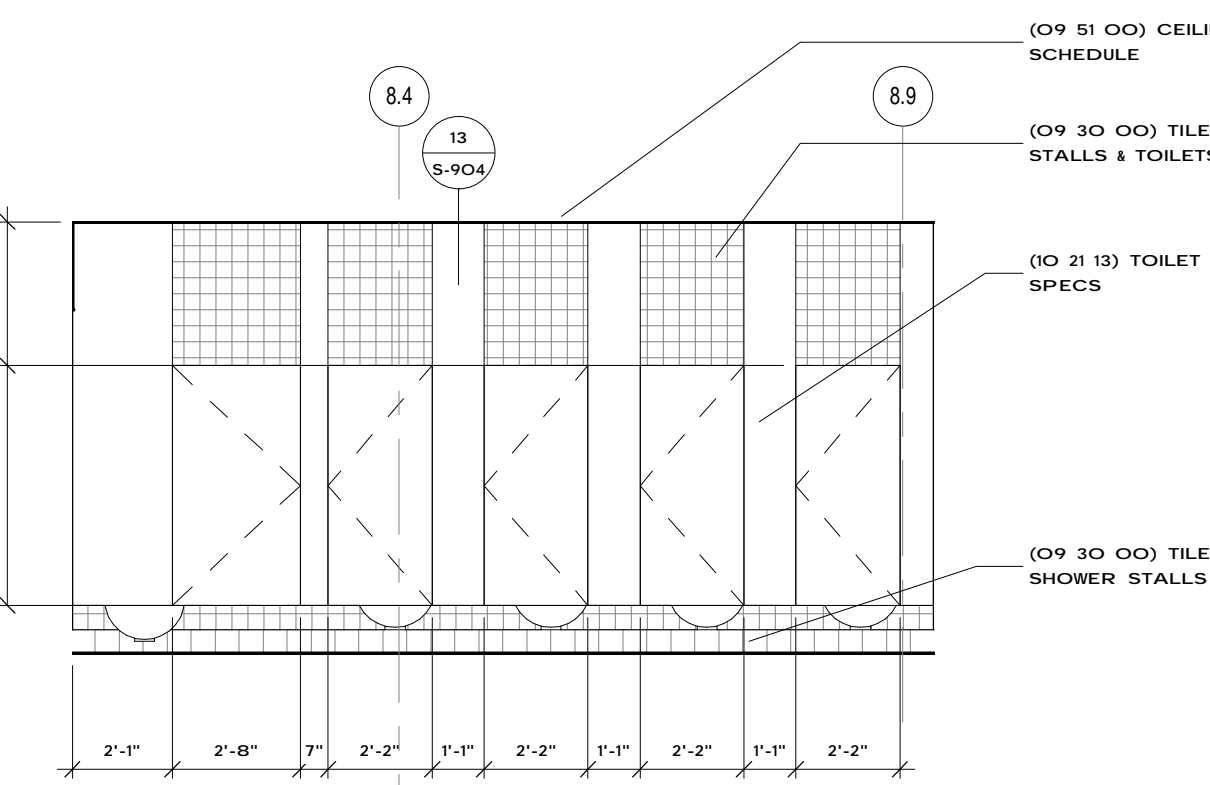

3 Men's Toilets 135-C - north wall
1/4" = 1'-0"

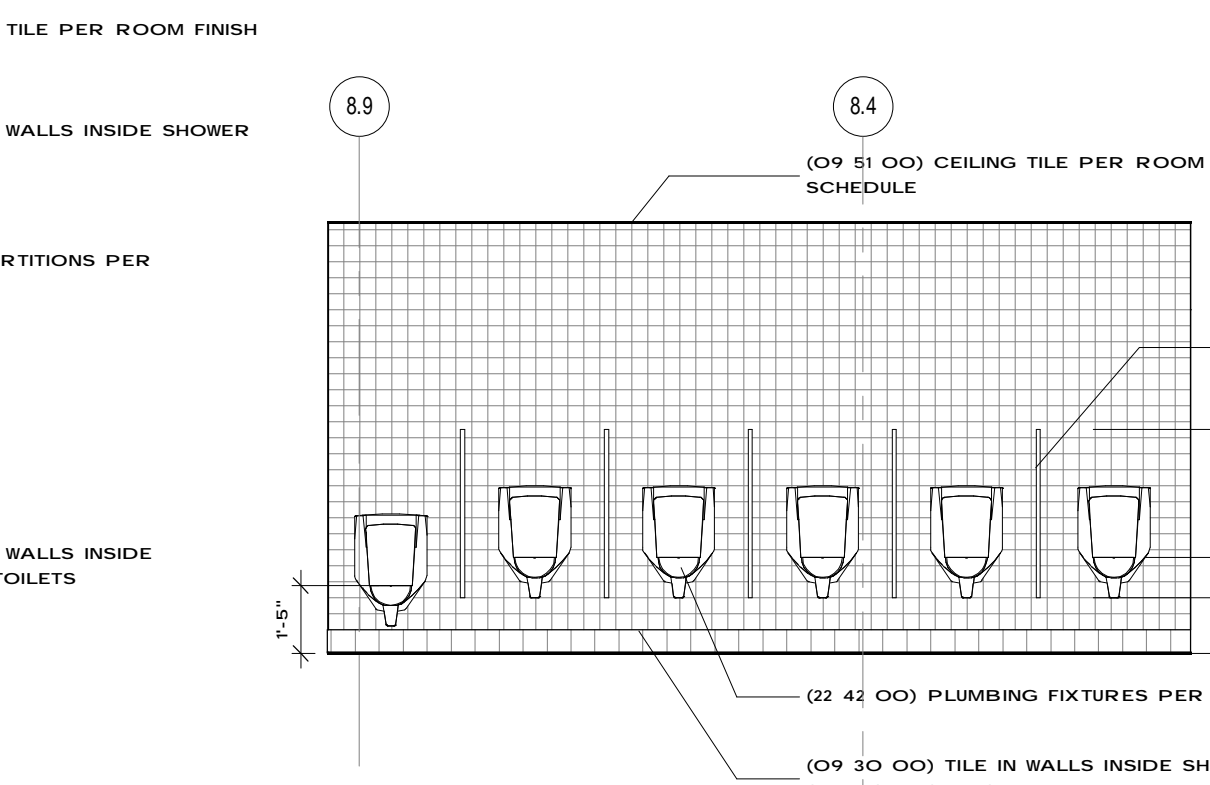

4 Men's Toilets 135-C - South Wall
1/4" = 1'-0"

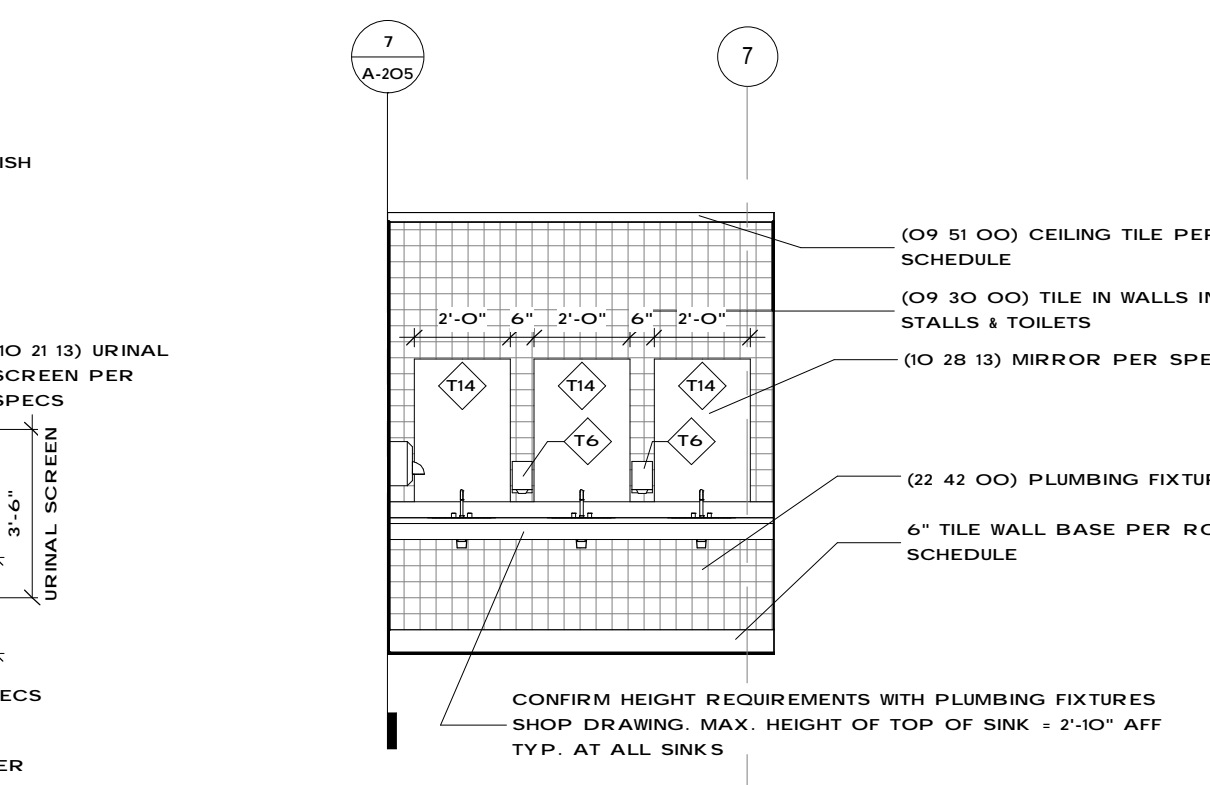

5 Women's Locker 130-B - Elevation 1
1/4" = 1'-0"

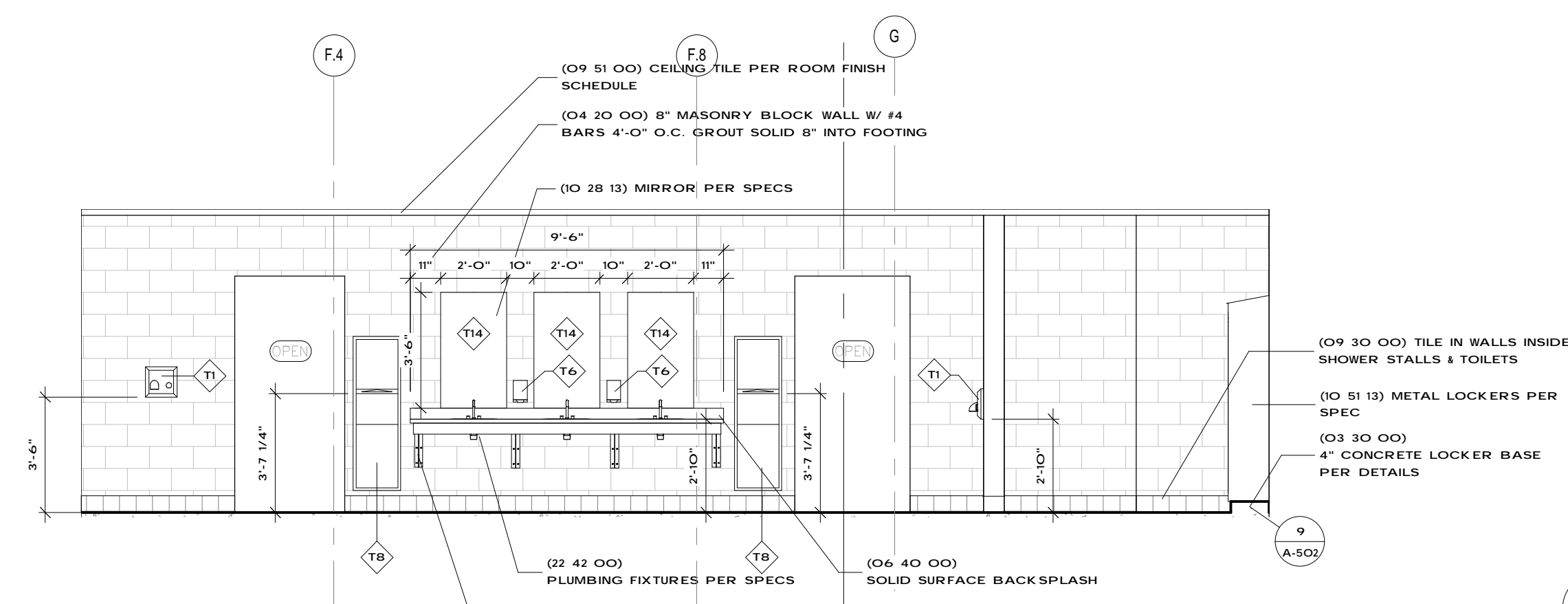

6 Men's Locker 135 - East Wall
1/4" = 1'-0"

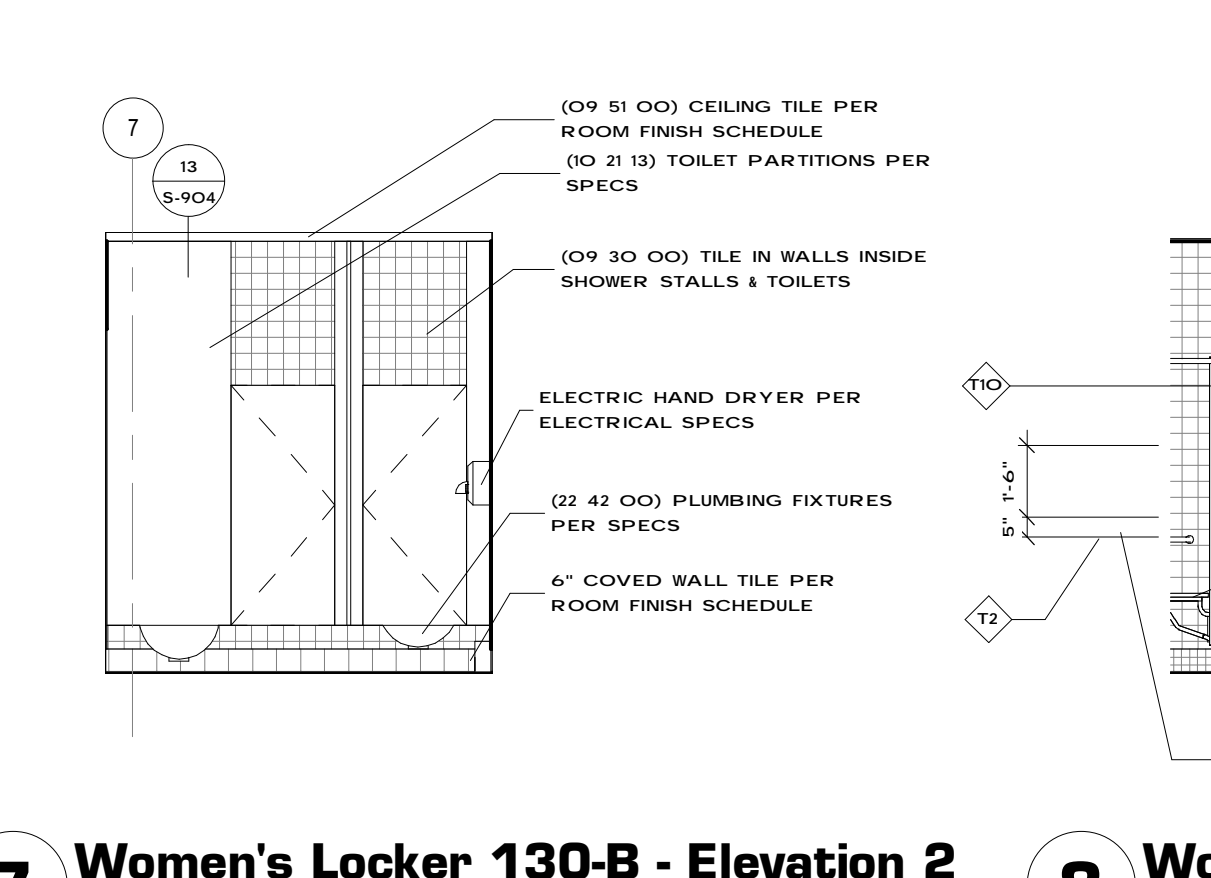

7 Women's Locker 130-B - Elevation 2
1/4" = 1'-0"

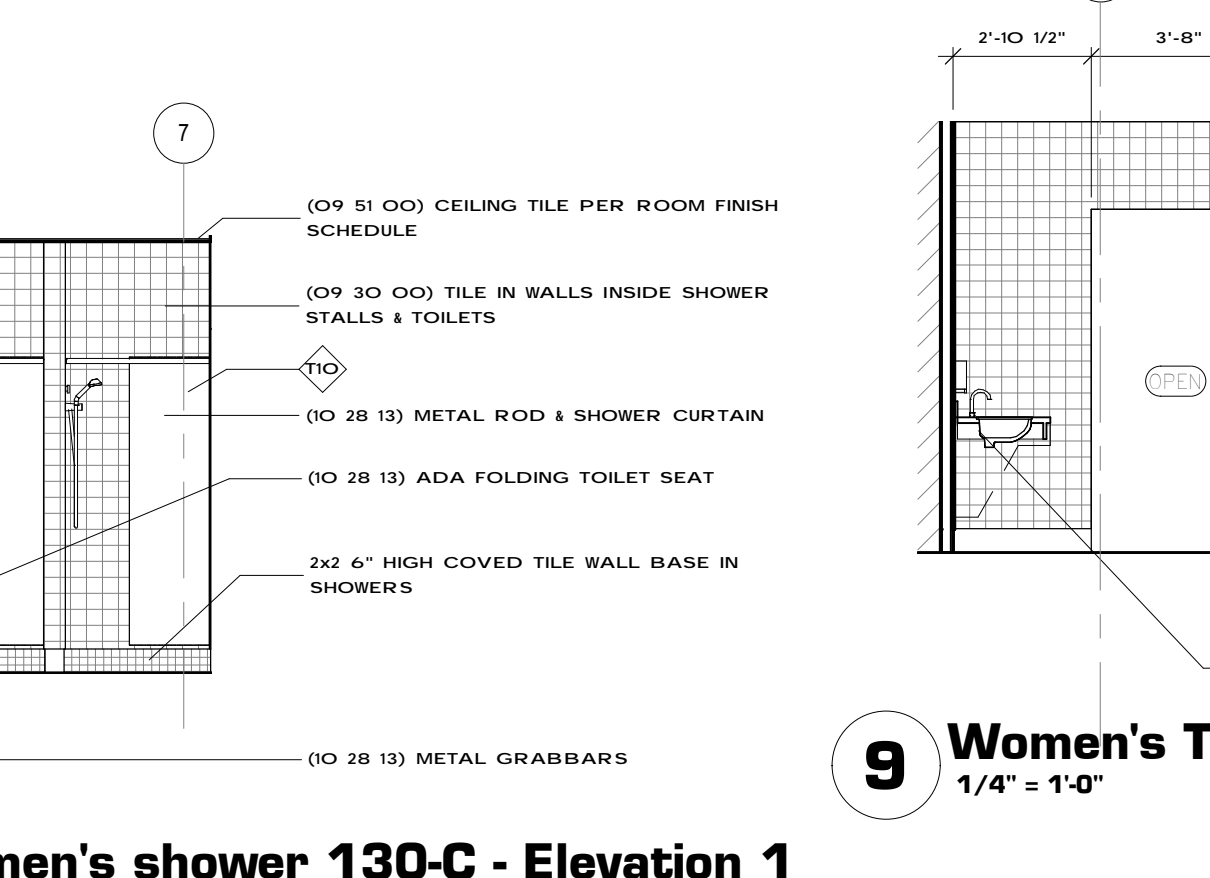

8 Women's shower 130-C - Elevation 1
1/4" = 1'-0"

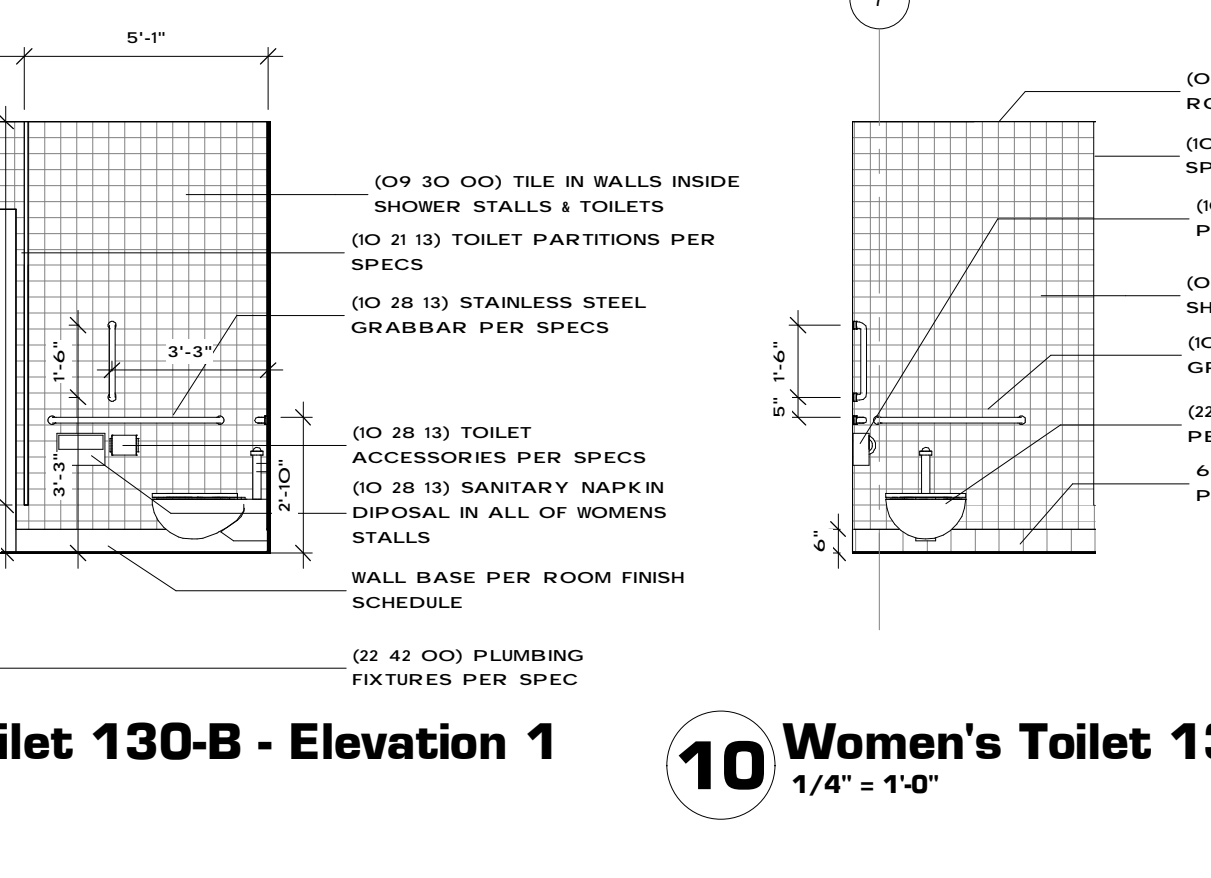

9 Women's Toilet 130-B - Elevation 1
1/4" = 1'-0"

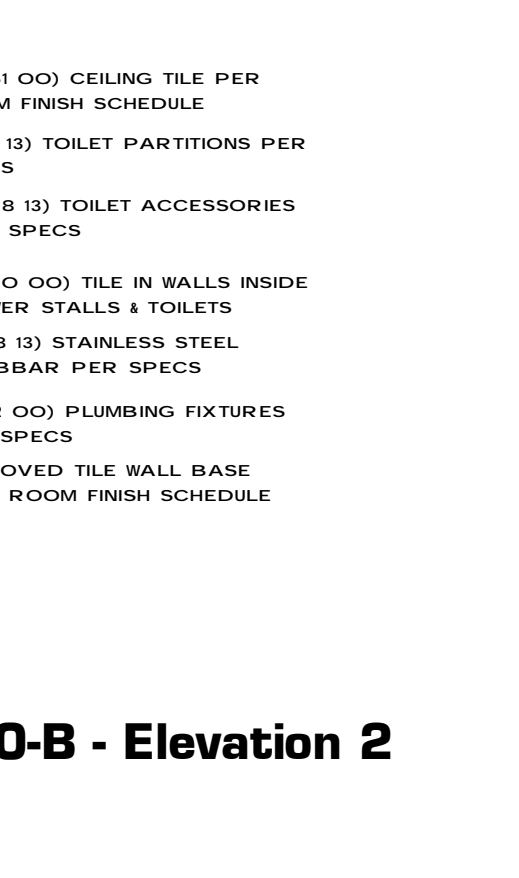

10 Women's Toilet 130-B - Elevation 2
1/4" = 1'-0"

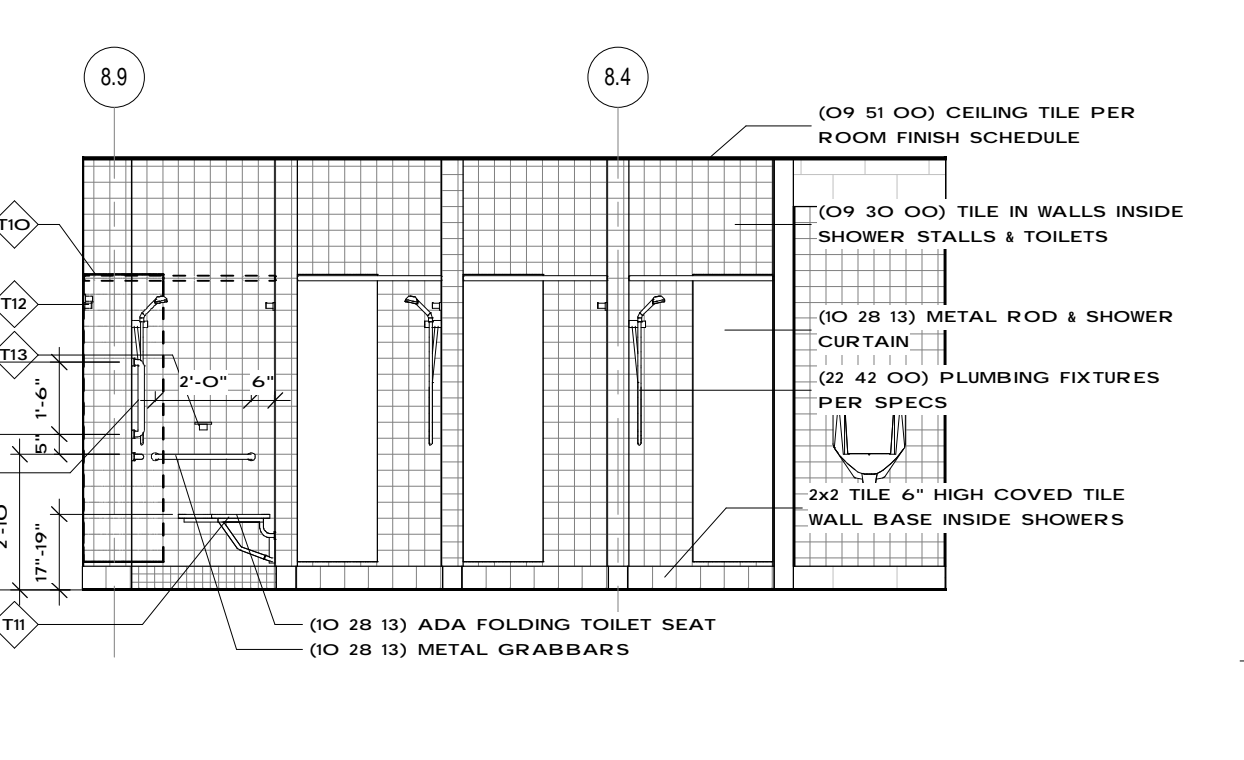

11 Men's Showers 135-B
1/4" = 1'-0"

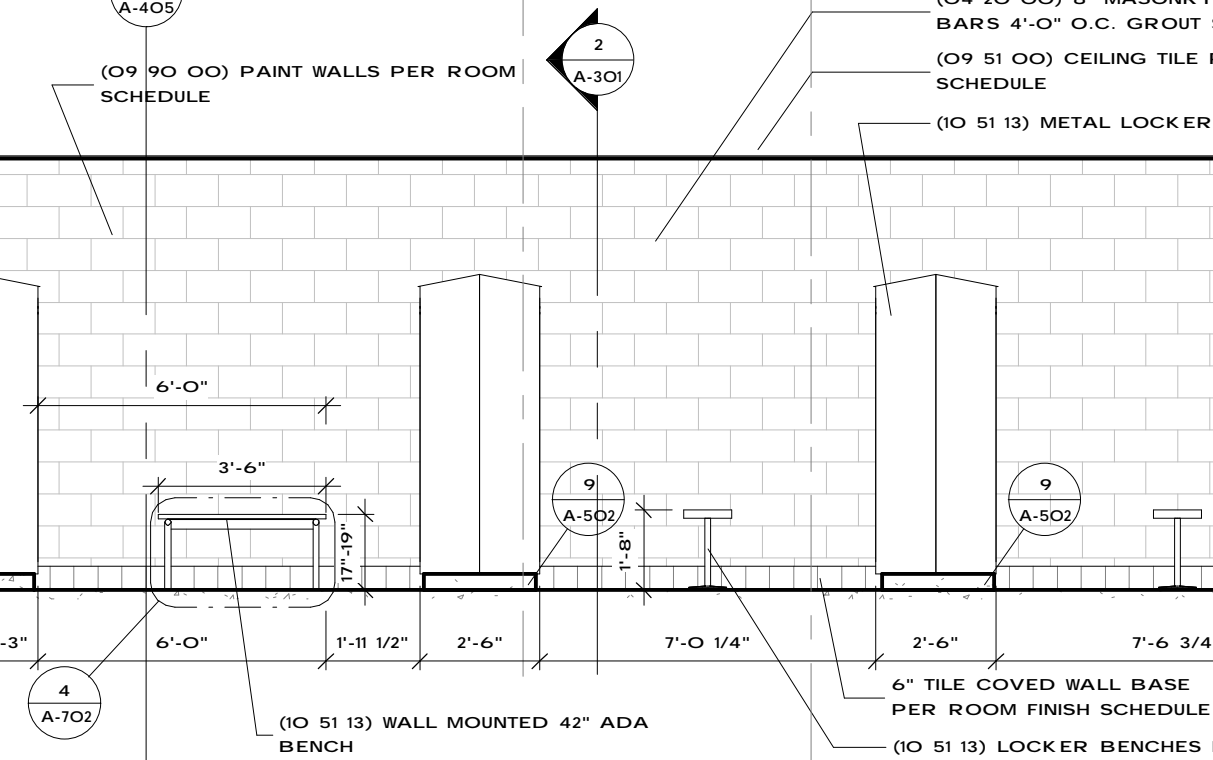

12 Men's Locker 135-A - Elevation
1/4" = 1'-0"

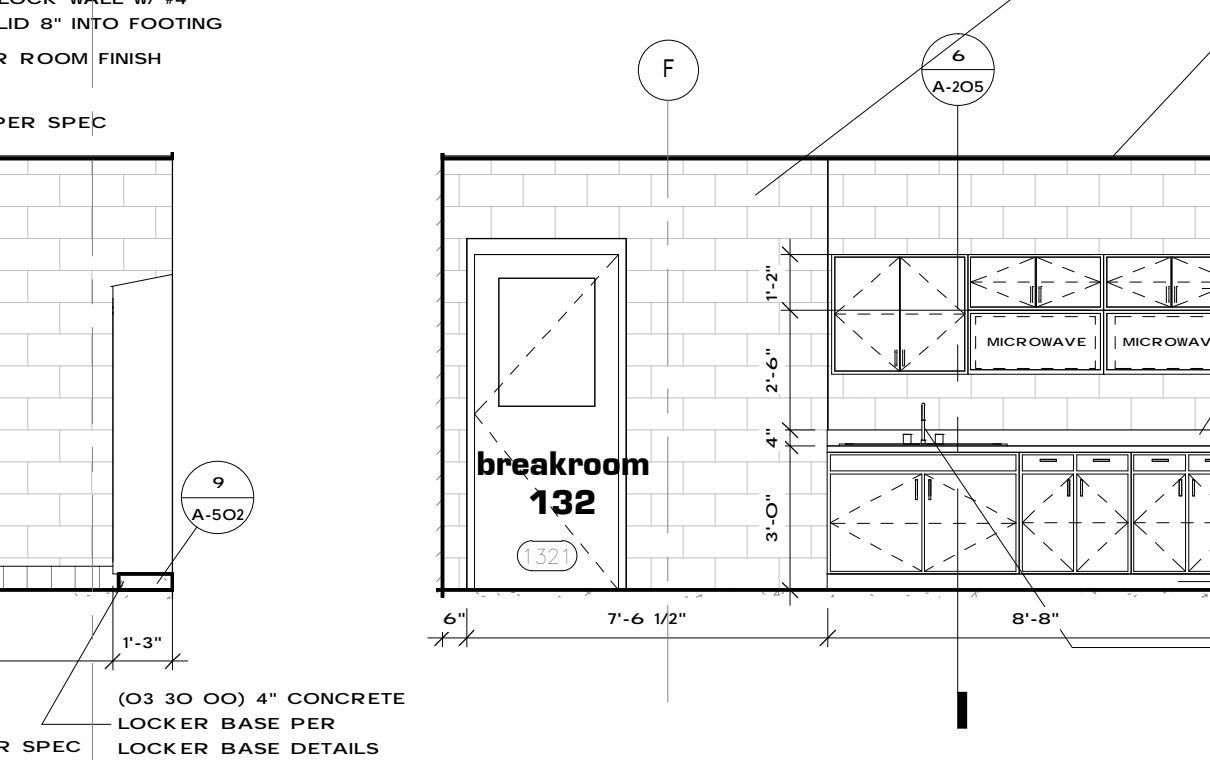

13 Breakroom 132 - west
1/4" = 1'-0"

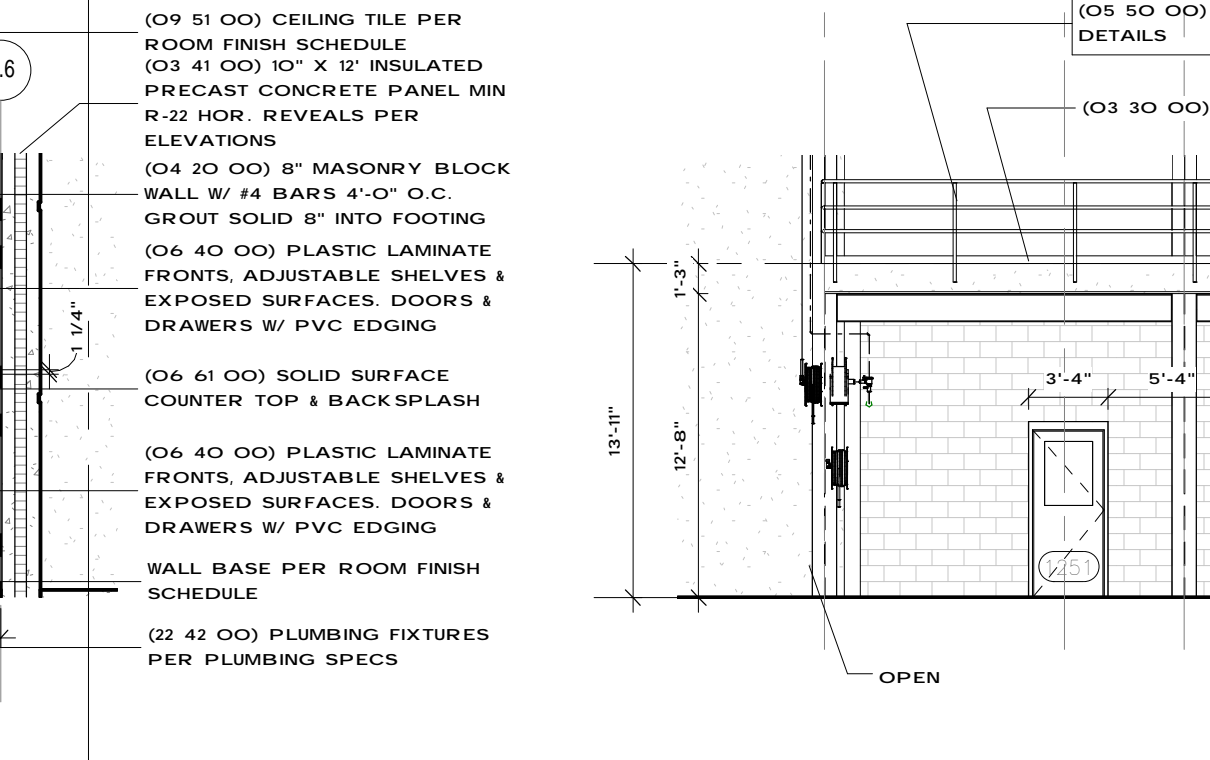

14 Large Vehicle Storage 138 - Elevation
1/8" = 1'-0"

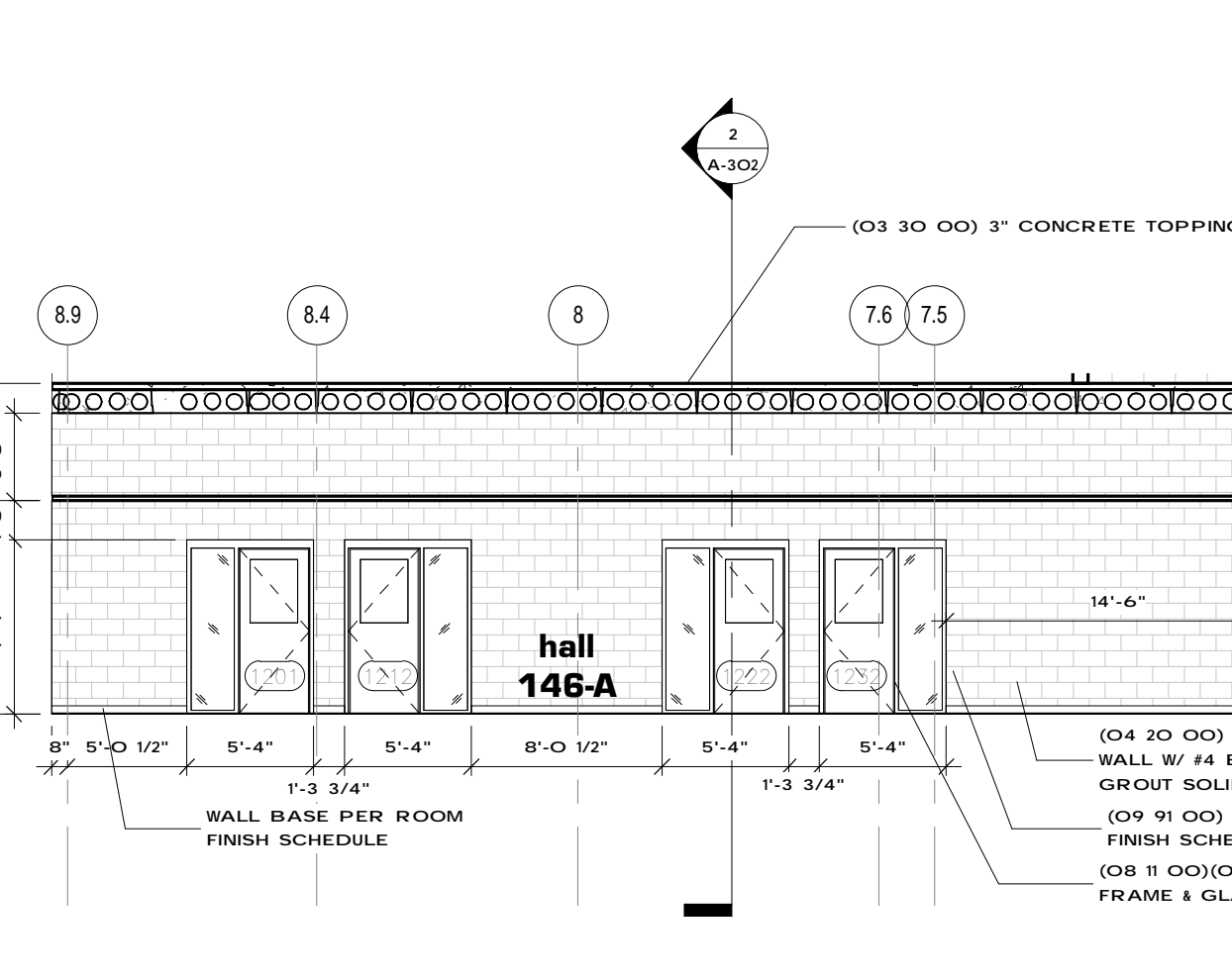

15 Hall 146-A - South Wall Elevation
1/8" = 1'-0"

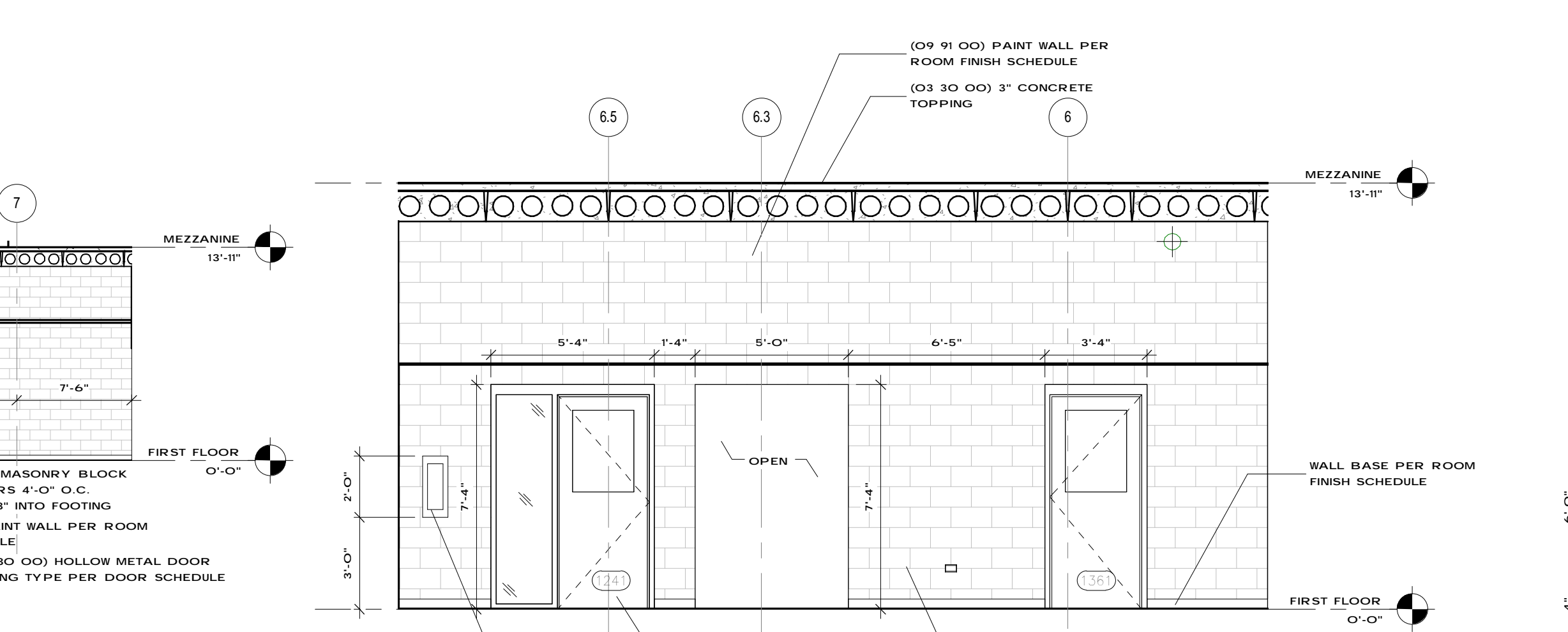

16 Parts 137 - South Wall Elevation
1/4" = 1'-0"

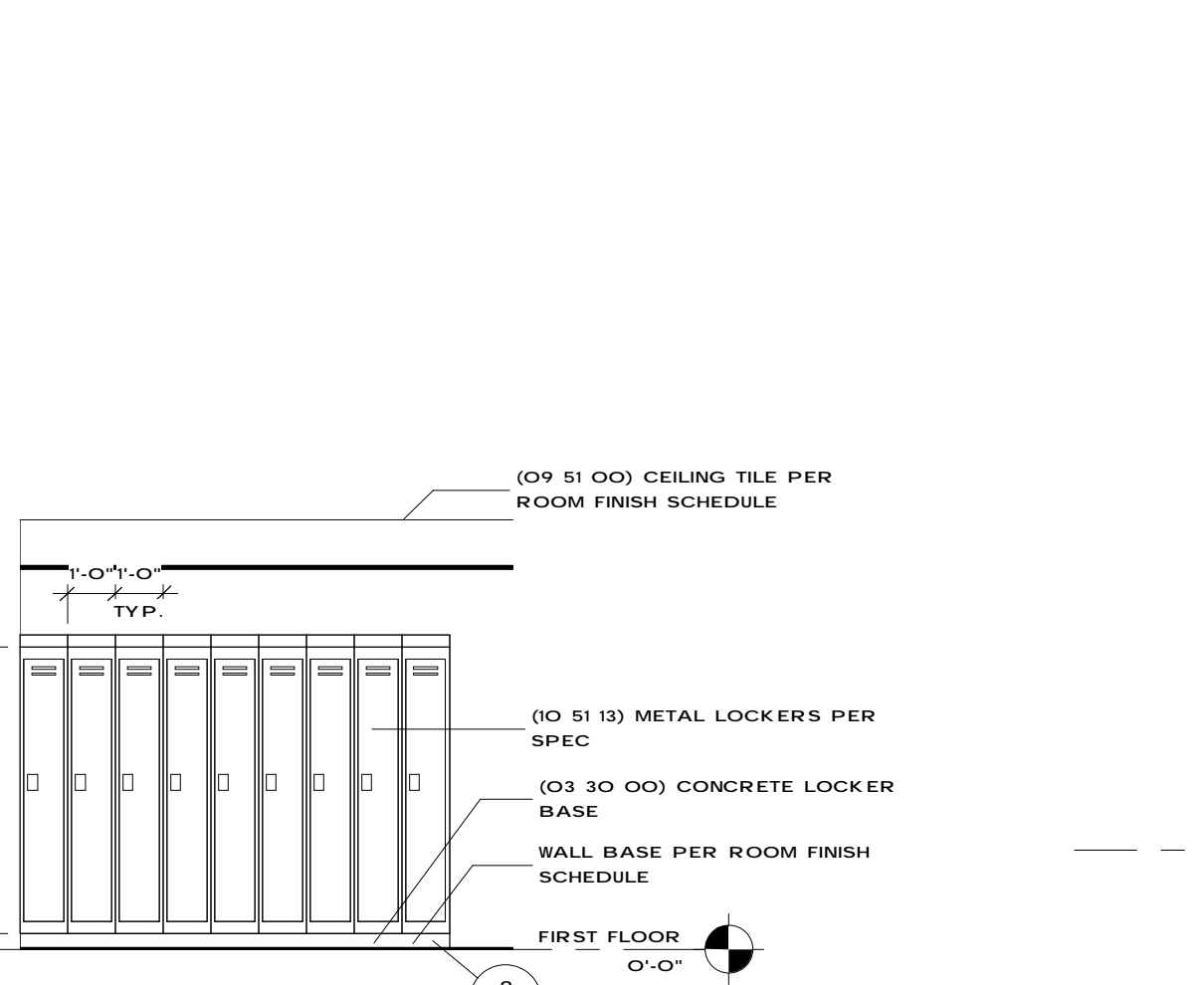

19 Typ. Locker Elevation
1/4" = 1'-0"

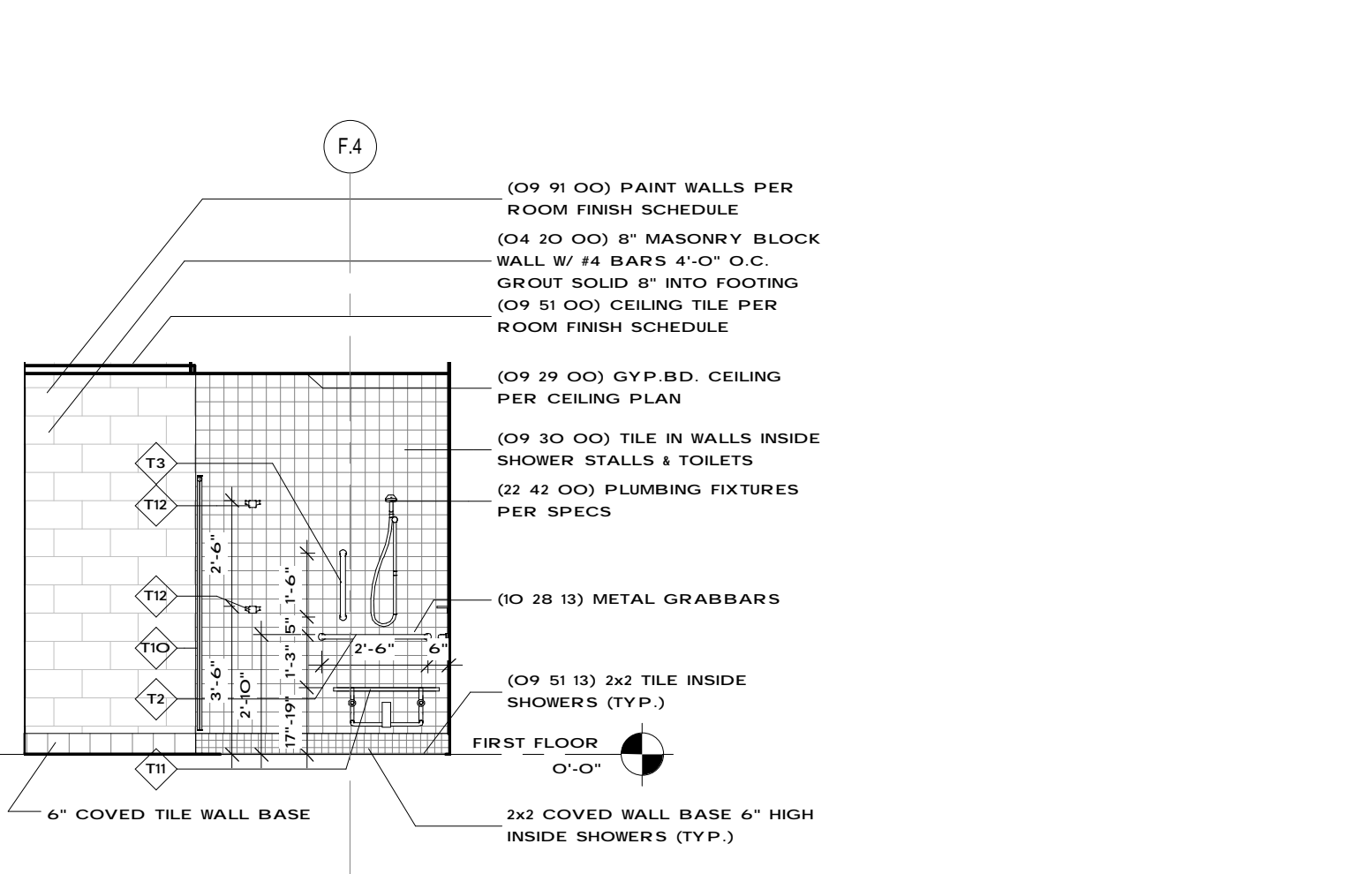

17 ADA Shower Elevation (Typ.)
1/4" = 1'-0"

TOILET ROOM & SHOWERS ACCESSORIES				
Type Mark	Description	Comments	Option 1	Option 2
T1	Electric Hand Dryer	Per Electric Specs		
T2	Heavy Duty Shower Grab Bars	Spec Section 10 28 13		
T3	Heavy Duty Grab Bar - 18"	Spec Section 10 28 13		
T4	Heavy Duty Grab Bar - 36"	Spec Section 10 28 13		
T5	Heavy Duty Grab Bar - 42"	Spec Section 10 28 13		
T6	Wall Mounted Soap Dispenser	Spec Section 10 28 13	Bay West # 91210	Kimberly Clark # 92145
T7	Toilet Paper Dispenser	Spec Section 10 28 13	Bay West # 80200 Dubl-Serv	Kimberly Clark # 09604
T8	Paper Towel Dispenser w/ Waste Receptacle	Spec Section 10 28 13	Bobrick # B-3944	Bradley #234
T9	Sanitary Napkin Disposal	Spec Section 10 28 13	Bobrick # B-353	Bradley #4737
T10	Shower Rod w/Curtain	Spec Section 10 28 13	Bobrick # B-207	Bradley #9538
T11	Folding Shower Seat	Spec Section 10 28 13	Bobrick # B-5181	Bradley # 956
T12	Shower Hook	Spec Section 10 28 13	Bobrick # B-672	Bradley # 9124
T13	Soap Dish - Wall Mounted	Spec Section 10 28 13	Bobrick # B-680	Bradley # 901
T14	Tempered Glass Mirror w/ Channel Frame	Spec Section 10 28 13	Bobrick # B-2436	Bradley # 781

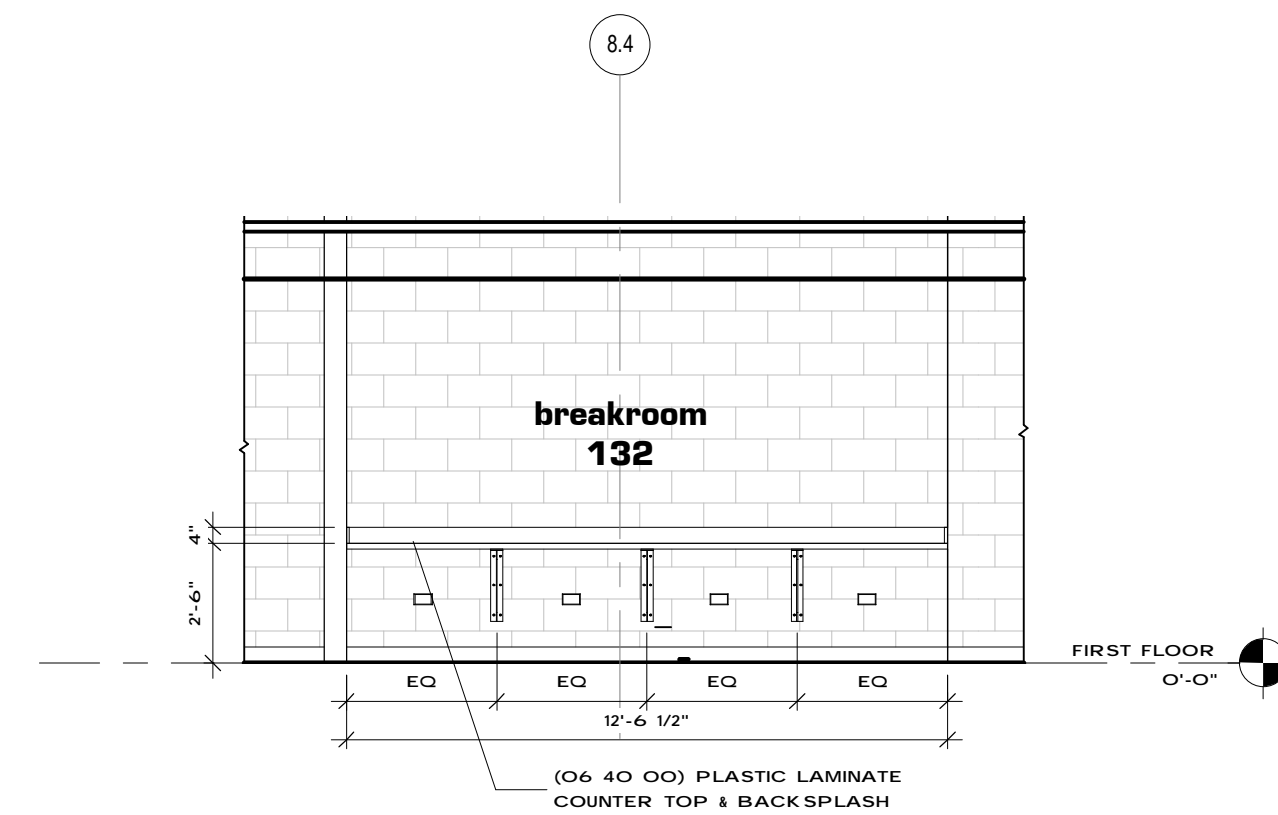

1 Counter @ Break Room 132
1/4" = 1'-0"

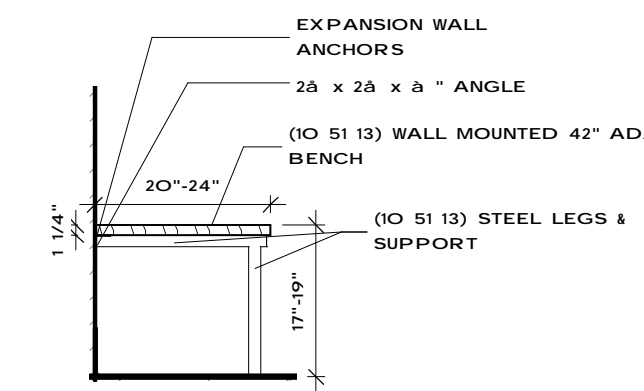

5 ADA Bench - Detail 2
1/2" = 1'-0"

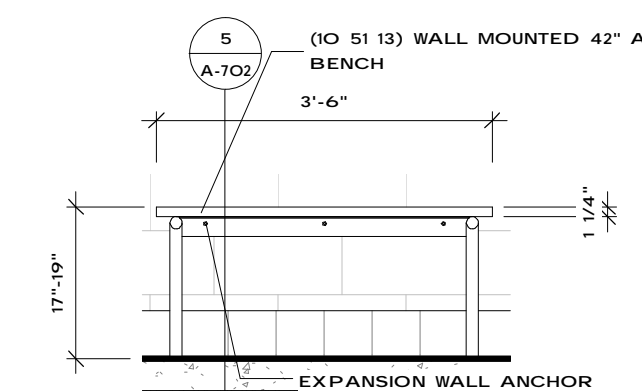

4 ADA Bench - Detail 1
1/2" = 1'-0"

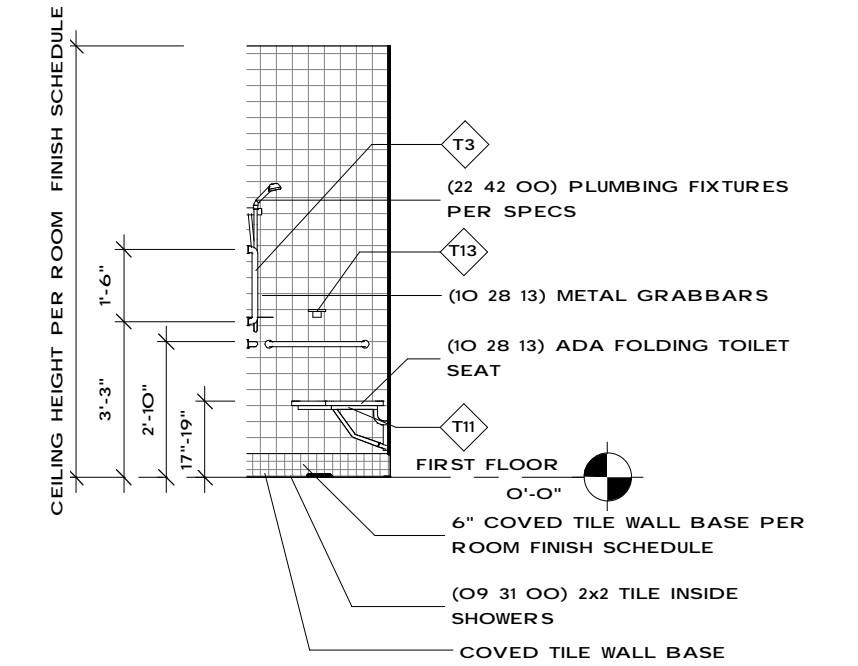

3 ADA Shower Elevation
1/4" = 1'-0"

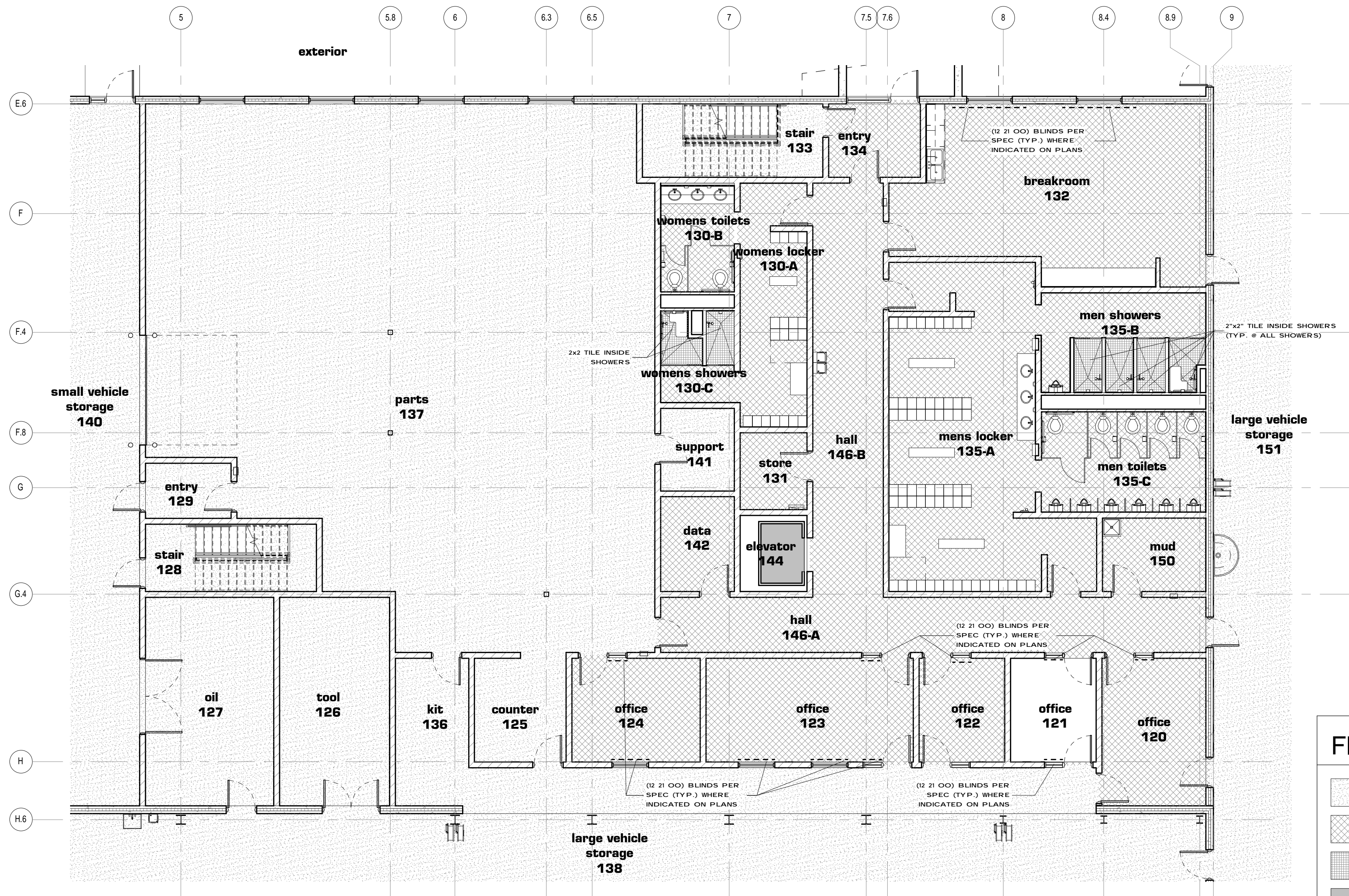

6 Floor Finish Plan - Offices
1/8" = 1'-0"

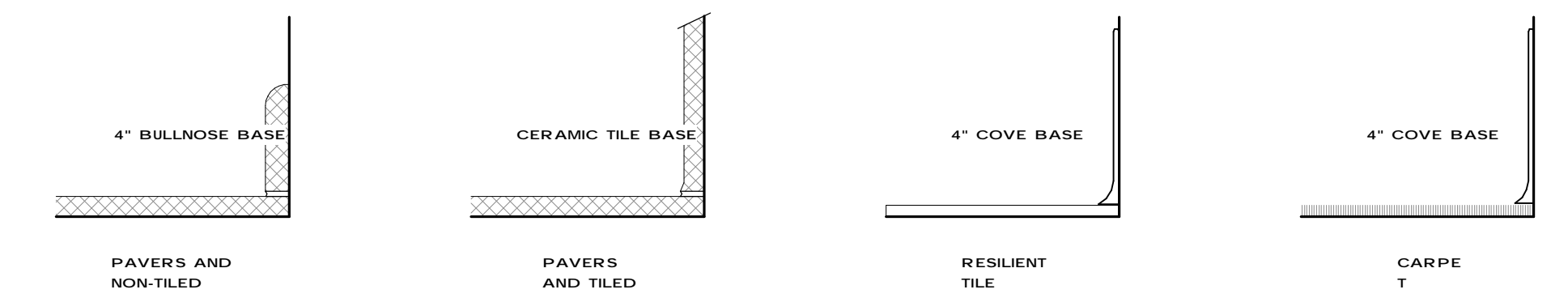
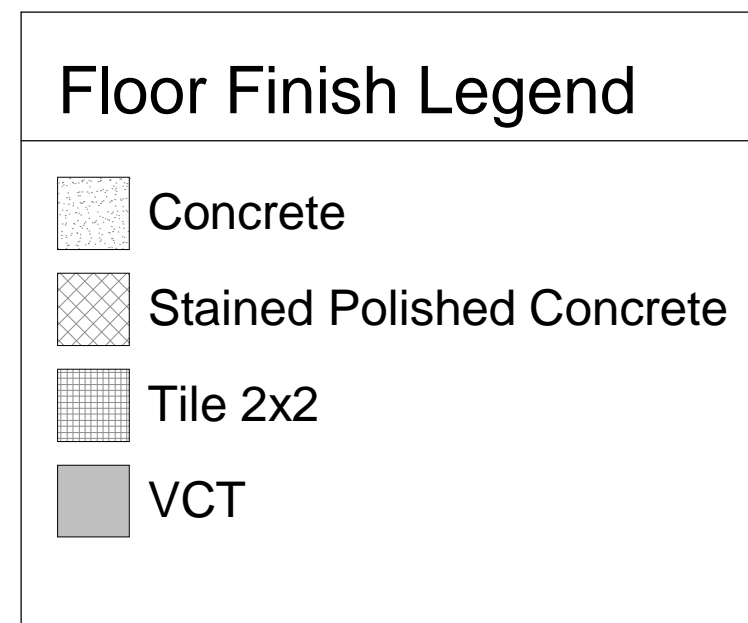

Base Details

TRANSITION NOTES:

1' OR GREATER - LEVELING BY GENERAL CONTRACTOR
LESS THAN 1' - LEVELING DONE BY FLOORING SUBCONTRACTOR

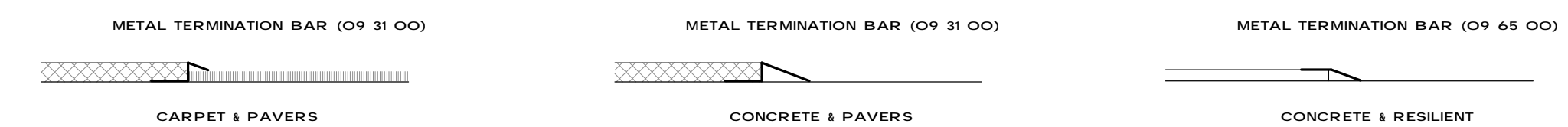

Threshold Details

Joint Details

CONCRETE SLAB NOTES

- CONCRETE TYPE "A"**
 4" CONCRETE SLAB - 6 x 6 W 1.4 x W 1.4 WWF
 W/ 10 MIL POLYETHYLENE VAPOR BARRIER
 OVER 4" COMPACTED CRUSHED STONE
- CONCRETE TYPE "B"**
 6" CONCRETE SLAB - 6 x 6 W 2.9 x W 2.9 WWF
 W/ 10 MIL POLYETHYLENE VAPOR BARRIER
 OVER 6" COMPACTED CRUSHED STONE
- CONCRETE TYPE "C"**
 8" CONCRETE W/ #3 EPOXY COATED REINF. 16" O.C. EACH WAY
 10" x 6" W 2.9 x W 2.9 EPOXY COATED HIGHWAY MESH
 W/ 10 MIL POLYETHYLENE VAPOR BARRIER
 OVER 8" COMPACTED LIMESTONE.
- #5 EPOXY COATED BARS REQ @ EXPANSION JOINTS OR END
 OF CONSTRUCTION JOINTS 16" O.C. 2'-0" LONG
- RADIANT FLOORING NOTES - ALTERNATE #4**
 AREAS TO RECEIVE RADIANT FLOORING SYSTEM BY H.V.A.C.
 CONTRACTOR TO INCLUDE 2" TYPE IX EXPANDED
 POLYSTYRENE INSULATION BY GENERAL CONTRACTOR.
 LIMESTONE BASE TO MAINTAIN THE SAME THICKNESS. VAPOR
 BARRIER TO BE PLACED BELOW INSULATION.

FOOTING SCHEDULE

NOTE: ALL STRIP FOOTINGS ARE "ST-1" UNLESS NOTED OTHERWISE

MARK	SIZE	REINFORCING
F-1	3'-3" x 3'-3" x 12"	4 - #5 BARS EACH WAY
F-2	4'-3" x 4'-3" x 12"	5 - #5 BARS EACH WAY
F-3	5'-0" x 5'-0" x 12"	6 - #5 BARS EACH WAY
F-4	6'-3" x 6'-3" x 12"	7 - #5 BARS EACH WAY
F-5	7'-5" x 7'-5" x 13"	7 - #6 BARS EACH WAY
F-6	7'-8" x 7'-8" x 13"	7 - #6 BARS EACH WAY
F-7	8'-3" x 8'-3" x 14"	8 - #6 BARS EACH WAY
ST-1	2'-0" x 1'-0"	3 - #5 BARS CONT.
ST-2	3'-0" x 1'-0"	4 - #5 BARS CONT.
ST-3	3'-6" x 1'-0"	4 - #5 BARS CONT.
ST-4	4'-10" x 1'-0"	5 - #5 BARS CONT. w. #5 BARS @ 18" O.C. PERPENDICULAR
ST-5	6'-0" x 1'-4"	6 - #5 BARS CONT. w/ #5 BARS @ 12" O.C. PERPENDICULAR

PIER SCHEDULE

MARK	SIZE	REINFORCING	TIES
P-1	16 X 16	4 - #8 BARS VERT	#3 BARS @ 16" O.C.
P-2	18 X 18	4 - #9 BARS VERT	#3 BARS @ 18" O.C.

COLUMN SCHEDULE

MARK	TYPE	BEARING	BASE PLATE
C-1	HSS60X60X1/4	-0' - 8"	12" X 1" X 1'-0"
C-2	HSS60X60X1/2	-0' - 8"	12" X 1-1/4" X 1'-0"
C-4	W10X39	-0' - 8"	14" X 1/2" X 1'-2"
C-5	W10X49	-0' - 8"	14" X 5/8" X 1'-2"
C-6	W12X65	-0' - 8"	16" X 1" X 1'-4"

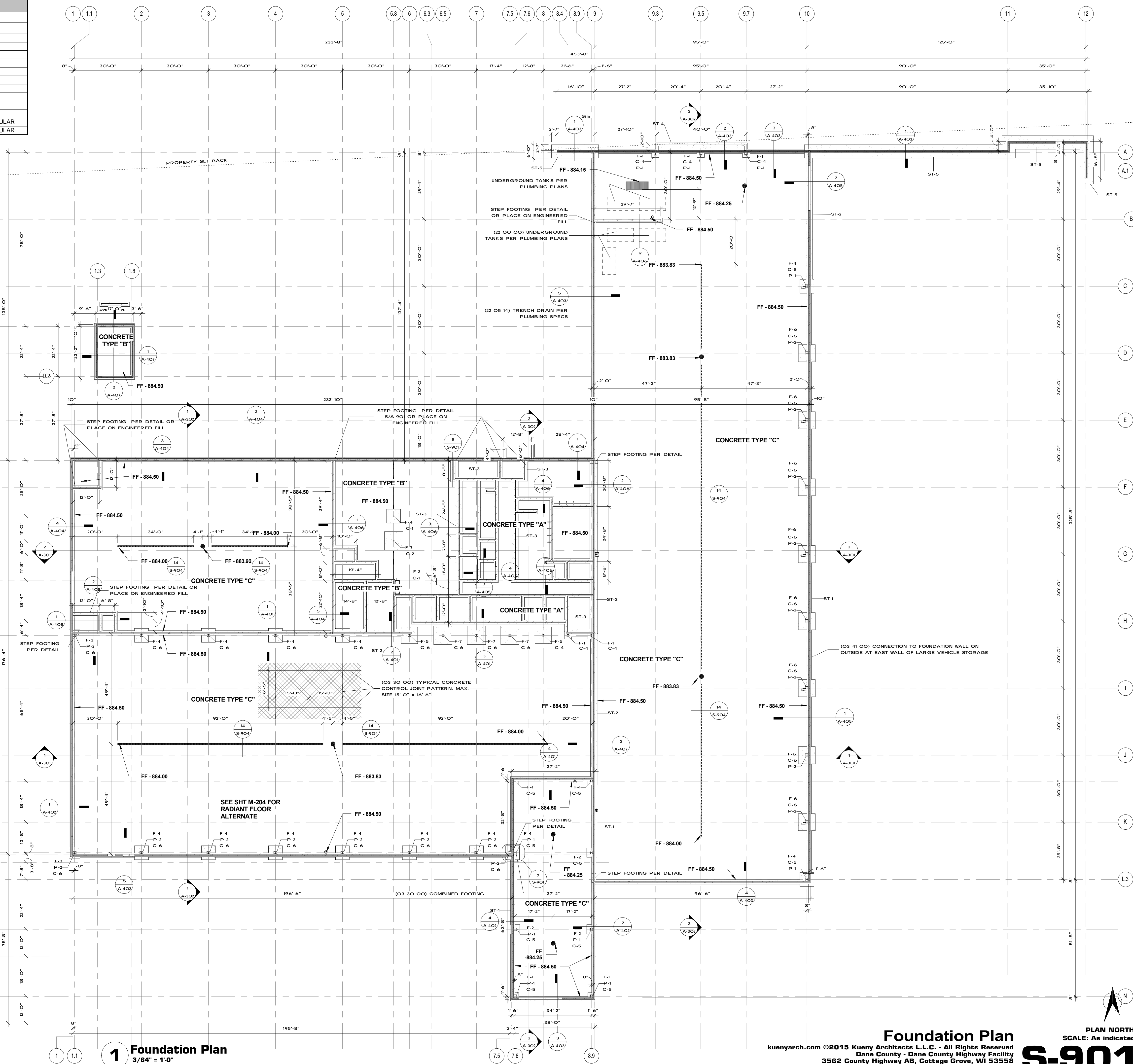
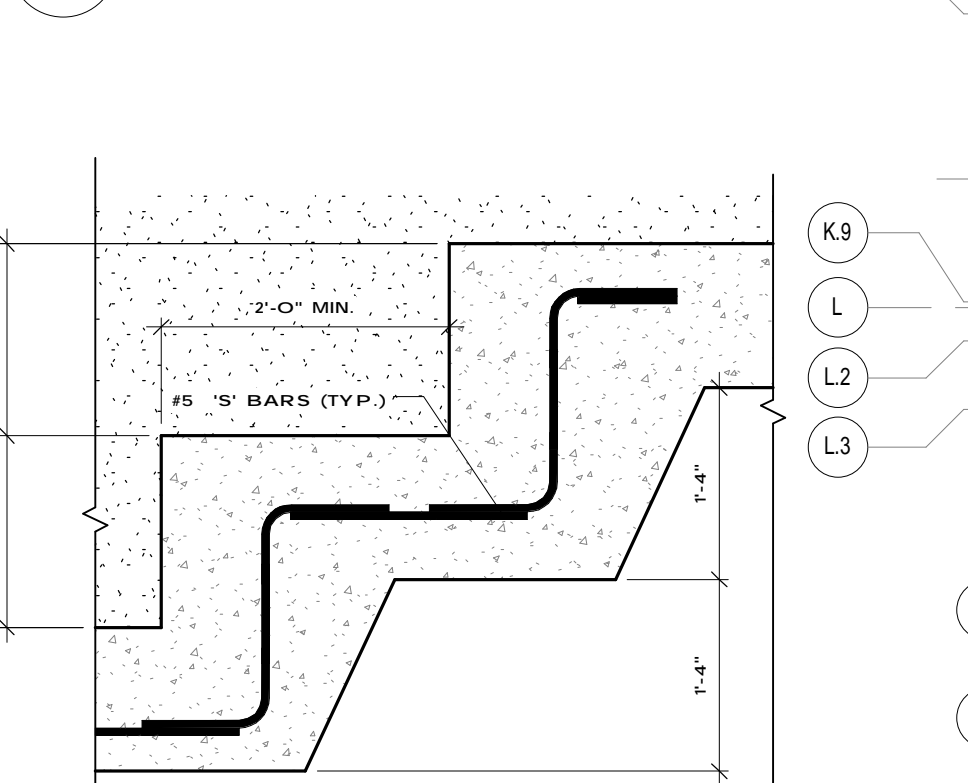
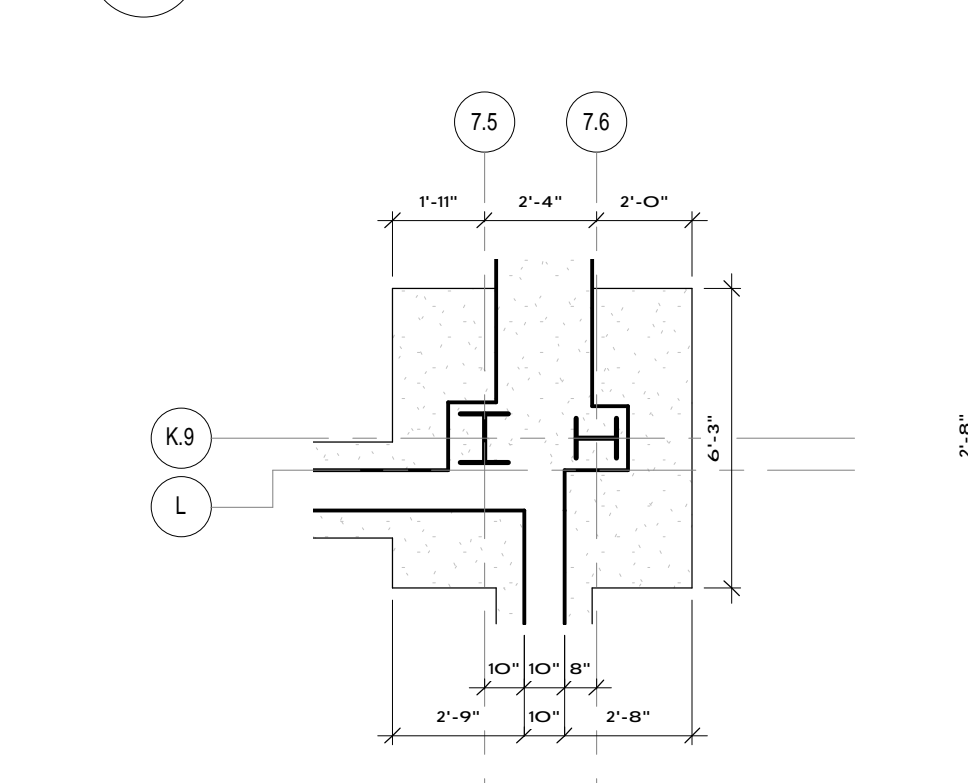
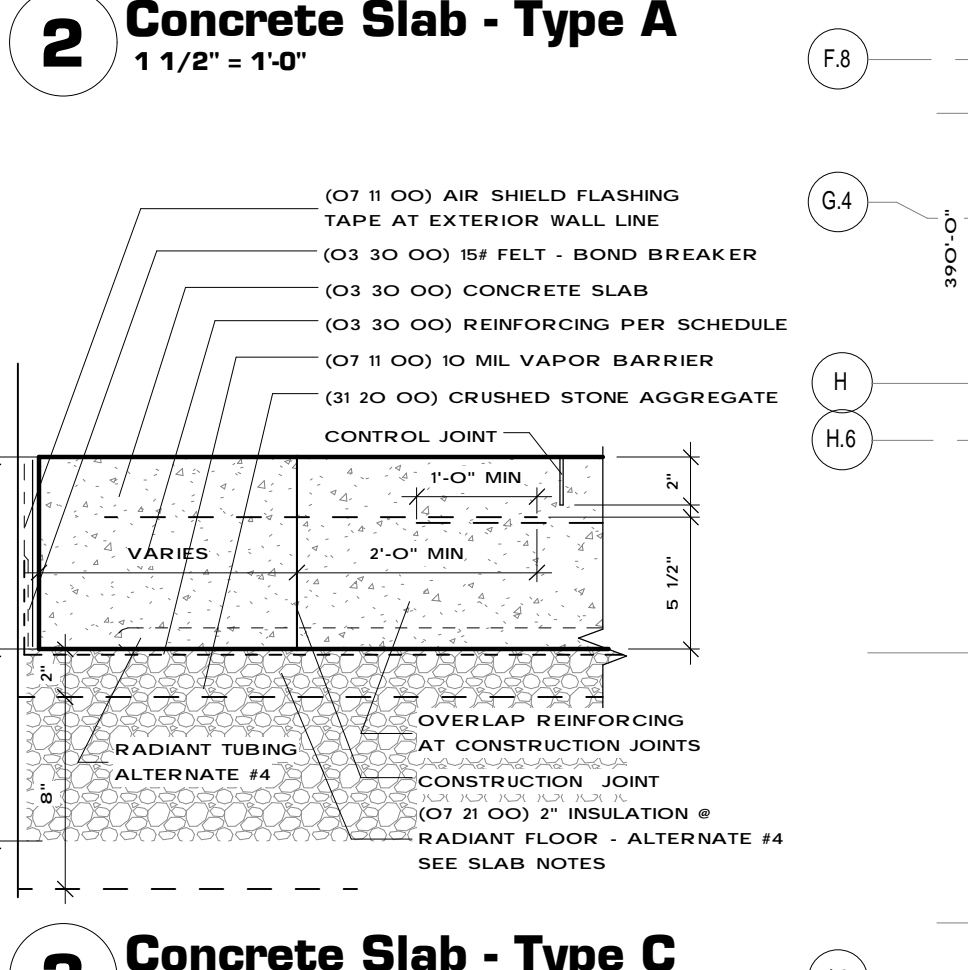
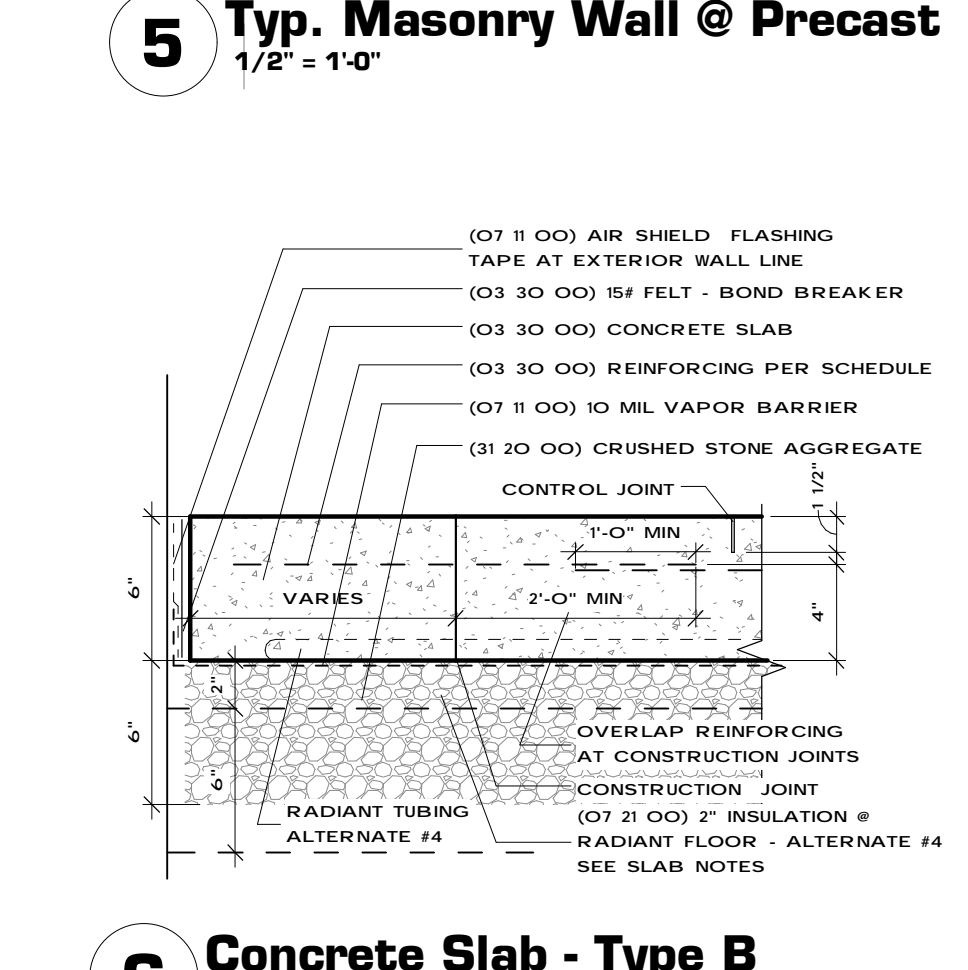
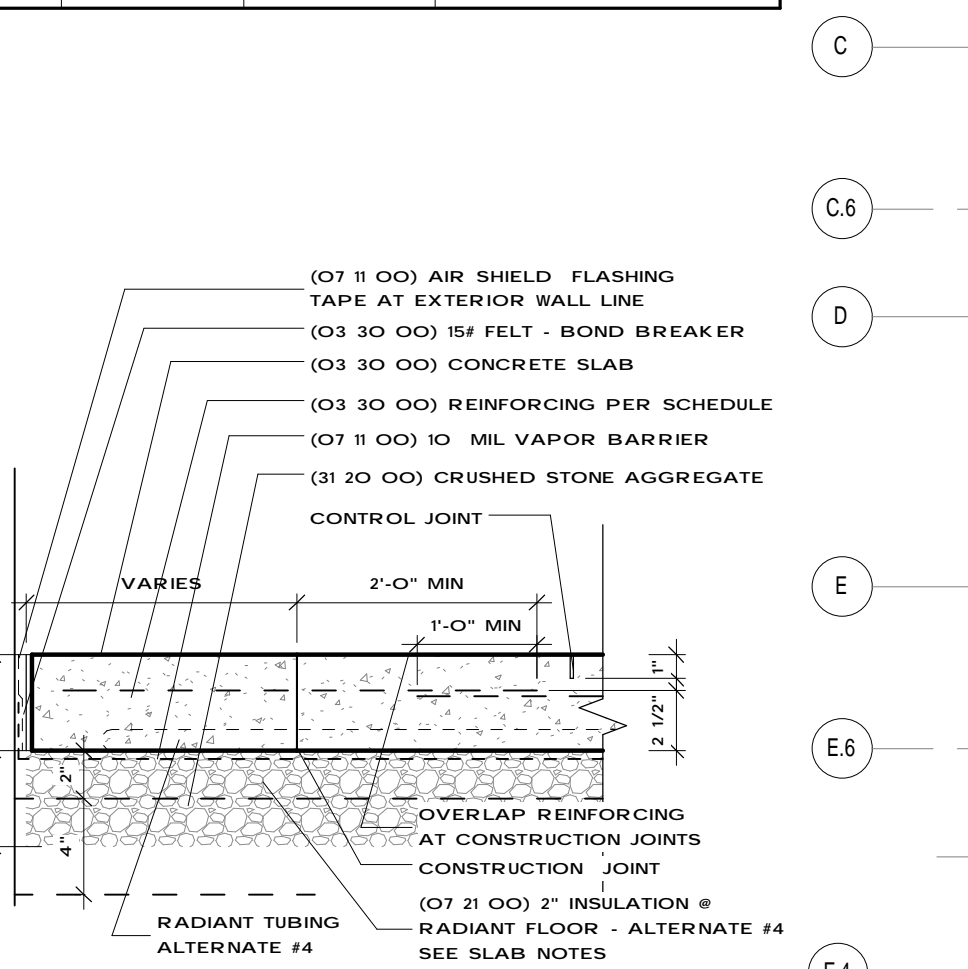
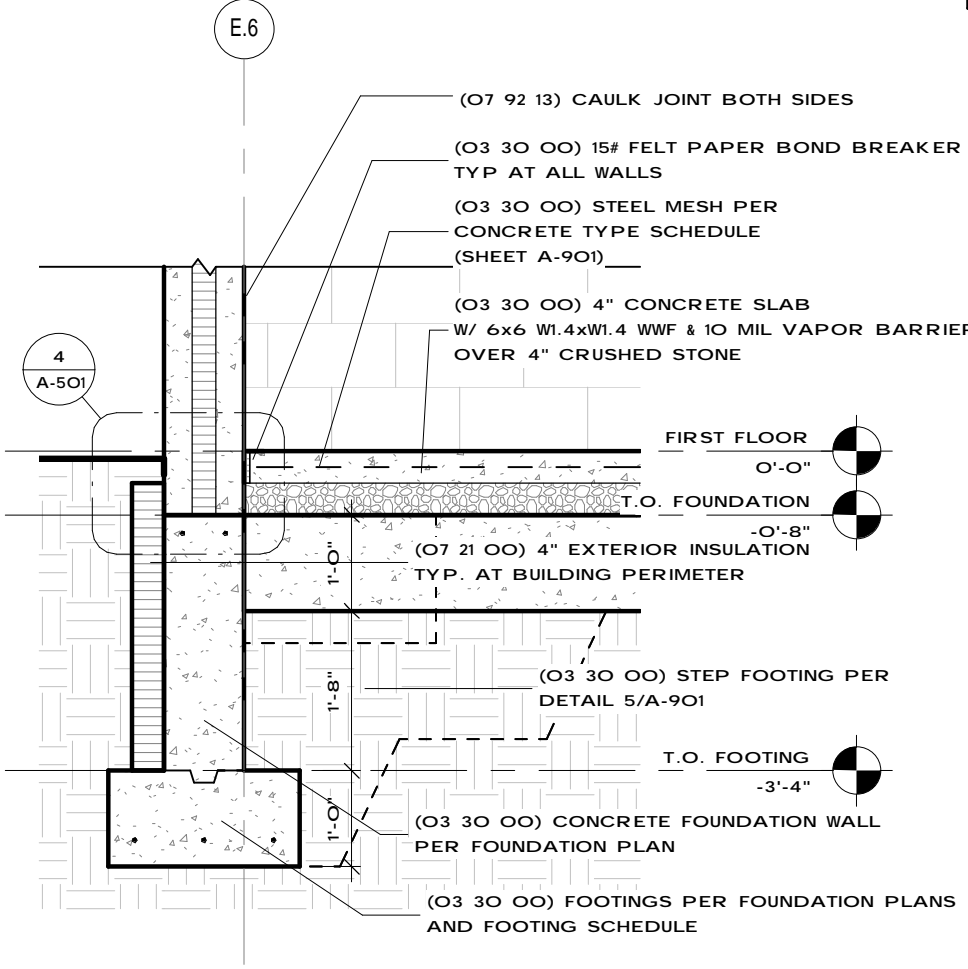

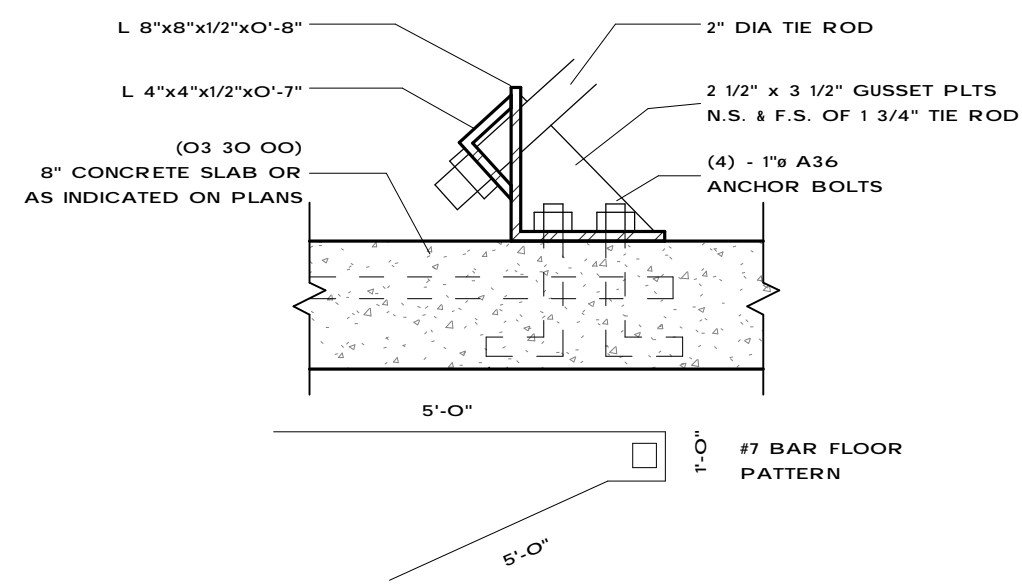

5 Cross Bracing Floor Attachment Detail
1" = 1'-0"

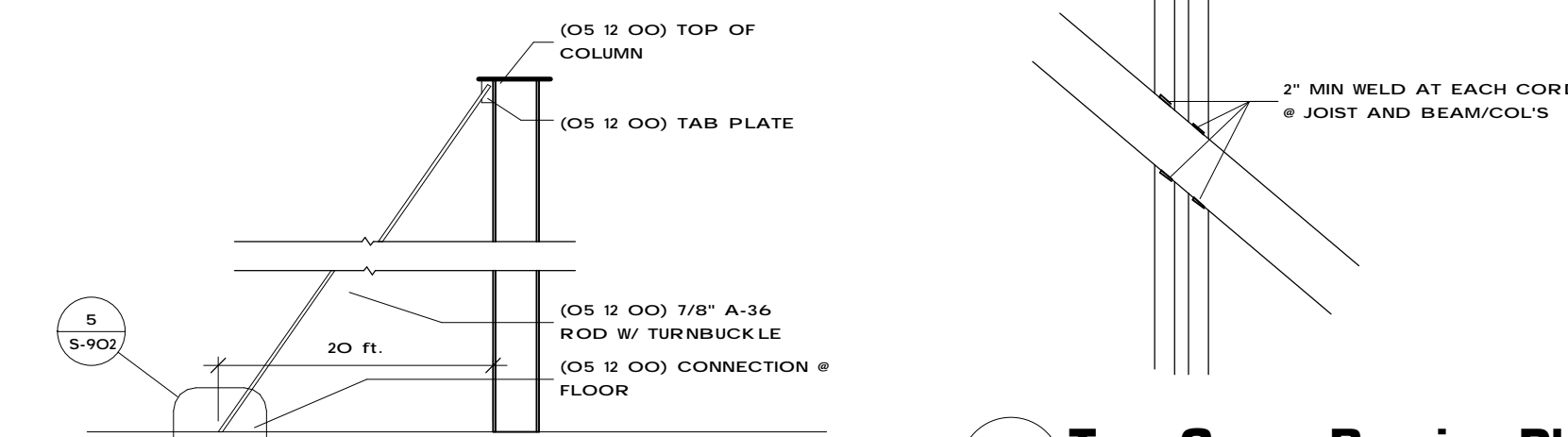

4 Bracing Detail
1/4" = 1'-0"

3 Typ. Cross Bracing Plate Detail
1 1/2" = 1'-0"

LINTEL SCHEDULE			
NOTE: ALL OPENINGS ON MASONRY WALLS TO HAVE A TYPE L-1 LINTEL UNLESS NOTED OTHERWISE AND AT ALL HVAC OPENINGS			
ALL LINTELS & JOISTS BEARING ON MASONRY WALLS TO HAVE A BASE PLATE TYPE BP-1 GROUTED SOLID INTO FOOTING U.N.O.			
MARK	TYPE	PLATE SIZE	REINFORCING AND END BEARING
BP-1	7" X 8" X 1/4"		(1) 4" STUD, GROUT (1) CORE TO FOOTING
L-1	2L3-1/2X3-1/2X1/4	7" X 1/4"	8" GROUT SOLID 3 COURSES
L-2	W16X26	7" X 1/4"	BP-1, GROUT CORE TO FOOTING W/ #5 BAR

Ⓜ = STRUCTURAL LOAD TAG

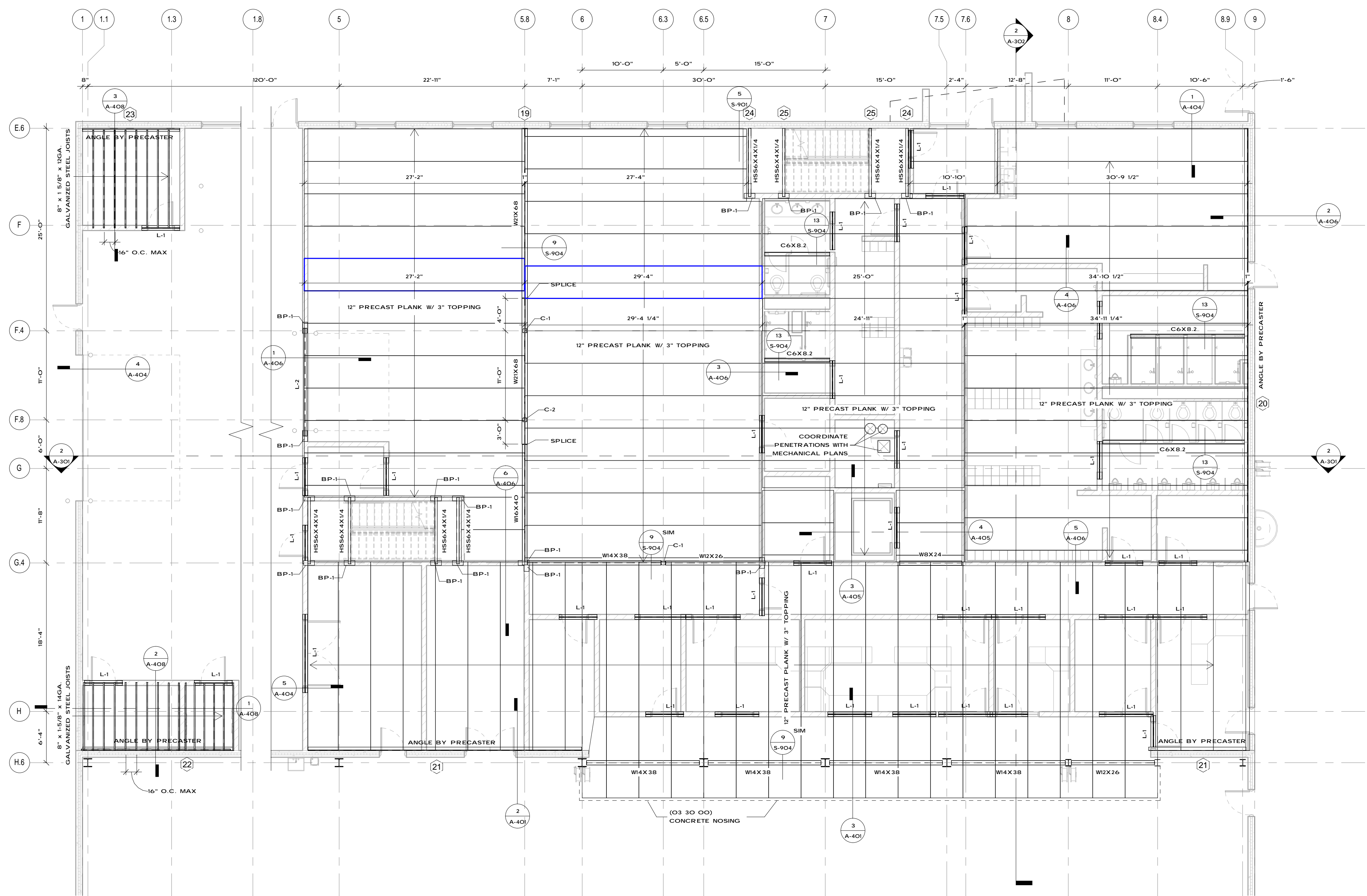

1 Mezzanine Framing Plan
1/8" = 1'-0"

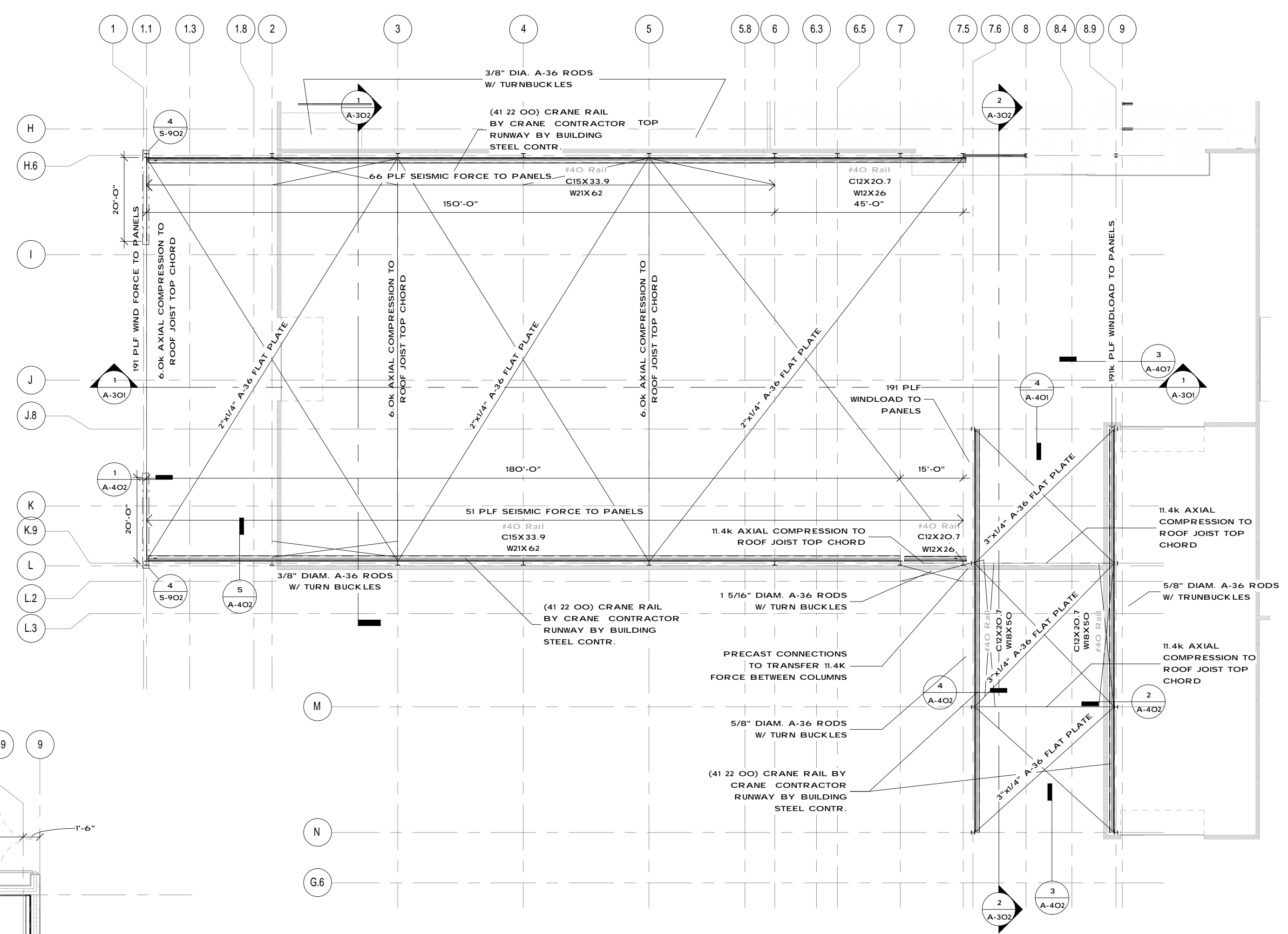

2 Crane Rail Framing Plan
3/64" = 1'-0"

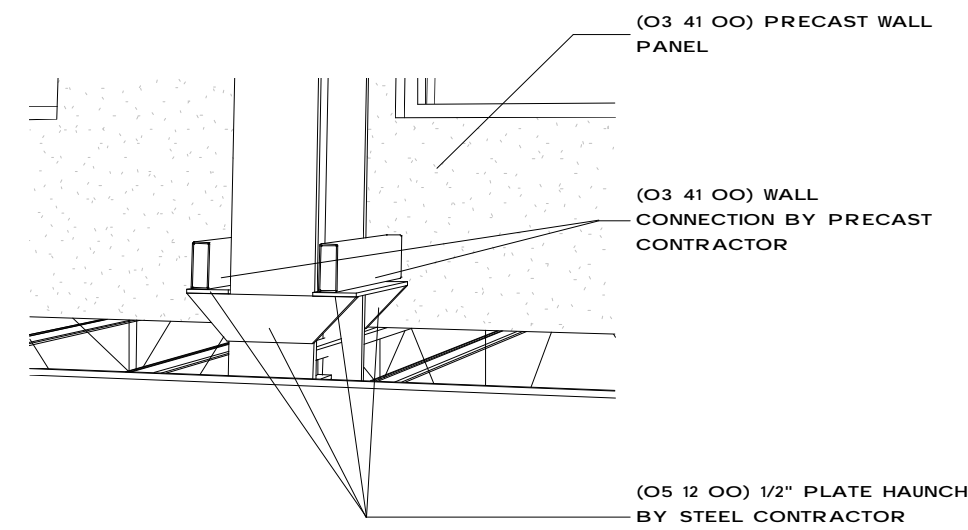

6 3D View of Typical Tall Wall Panel Haunch

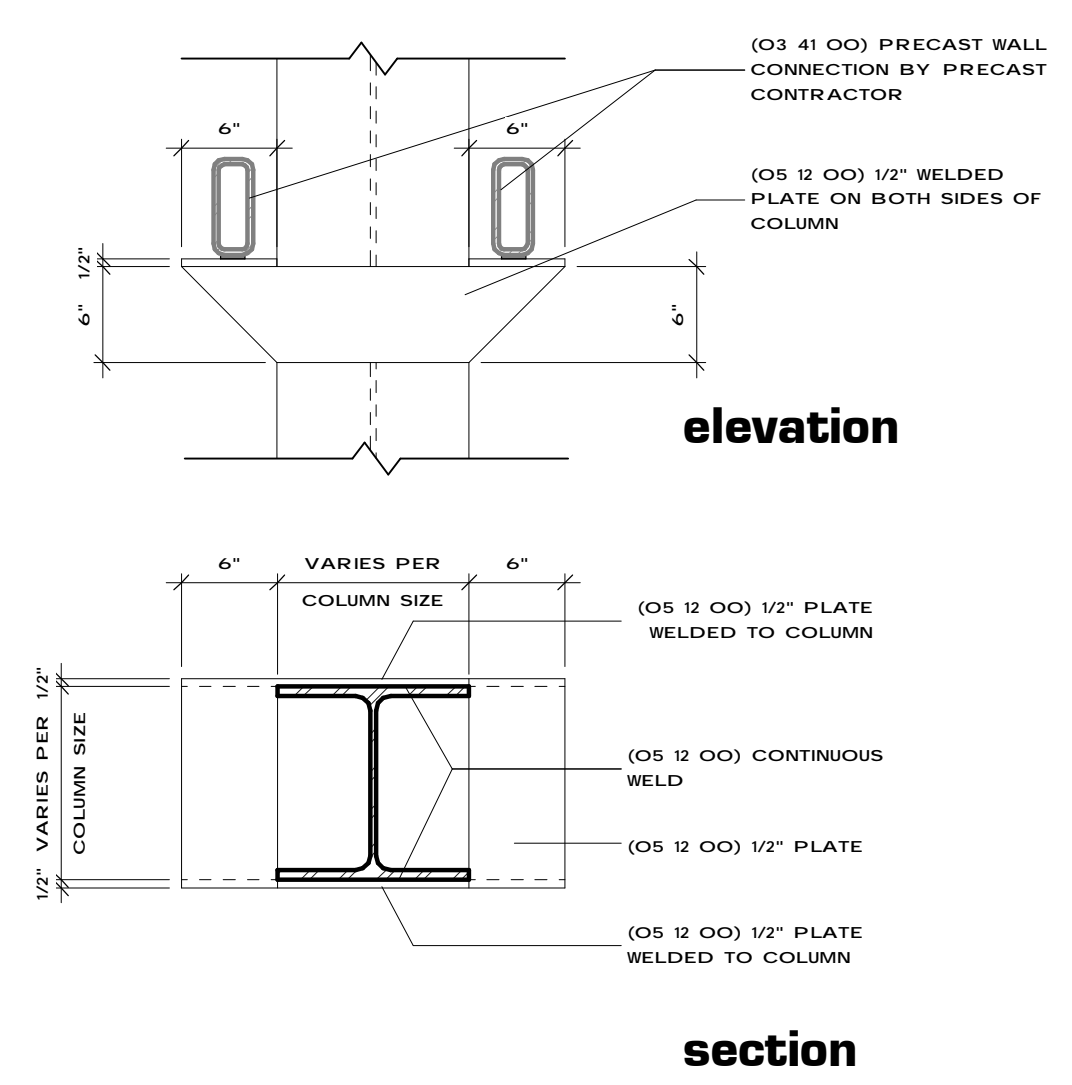

7 Tall Precast Wall Haunch Details

MARK	CONCENTRATED LOAD			UNIFORM LOAD		
	LL (k)	DL (k)	TL (k)	LL (plf)	DL (plf)	TL (plf)
1	0.0	0.0	0.0	63	45	108
2	4.9	4.3	9.2	0	0	0
3	4.9	4.4	9.3	0	0	0
4	4.9	4.6	9.5	0	0	0
5	4.9	4.6	9.5	0	0	0
6	2.8	2.4	5.2	0	0	0
7	6.0	4.3	10.3	0	0	0
8	6.0	5.7	11.7	0	0	0
9	6.0	4.4	10.4	0	0	0
10	4.0	3.6	7.6	0	0	0
11	7.1	5.7	12.8	0	0	0
12	7.1	6.0	13.1	0	0	0
13	6.3	6.6	12.9	0	0	0
14	6.3	5.7	12.0	0	0	0
15	6.3	5.7	12.0	0	0	0
16	6.0	5.7	11.7	0	0	0
17	0.9	1.0	1.9	0	0	0
18	1.5	1.2	2.7	0	0	0
19	37.0	36.7	73.7	0	0	0
20	0.0	0.0	0.0	2,188	2,126	4314
21	0.0	0.0	0.0	1,458	1,418	2876
22	0.0	0.0	0.0	563	170	733
23	0.0	0.0	0.0	750	232	982
24	1.0	0.5	1.5	0	0	0
25	3.1	1.0	4.1	0	0	0

= STRUCTURAL LOAD TAG

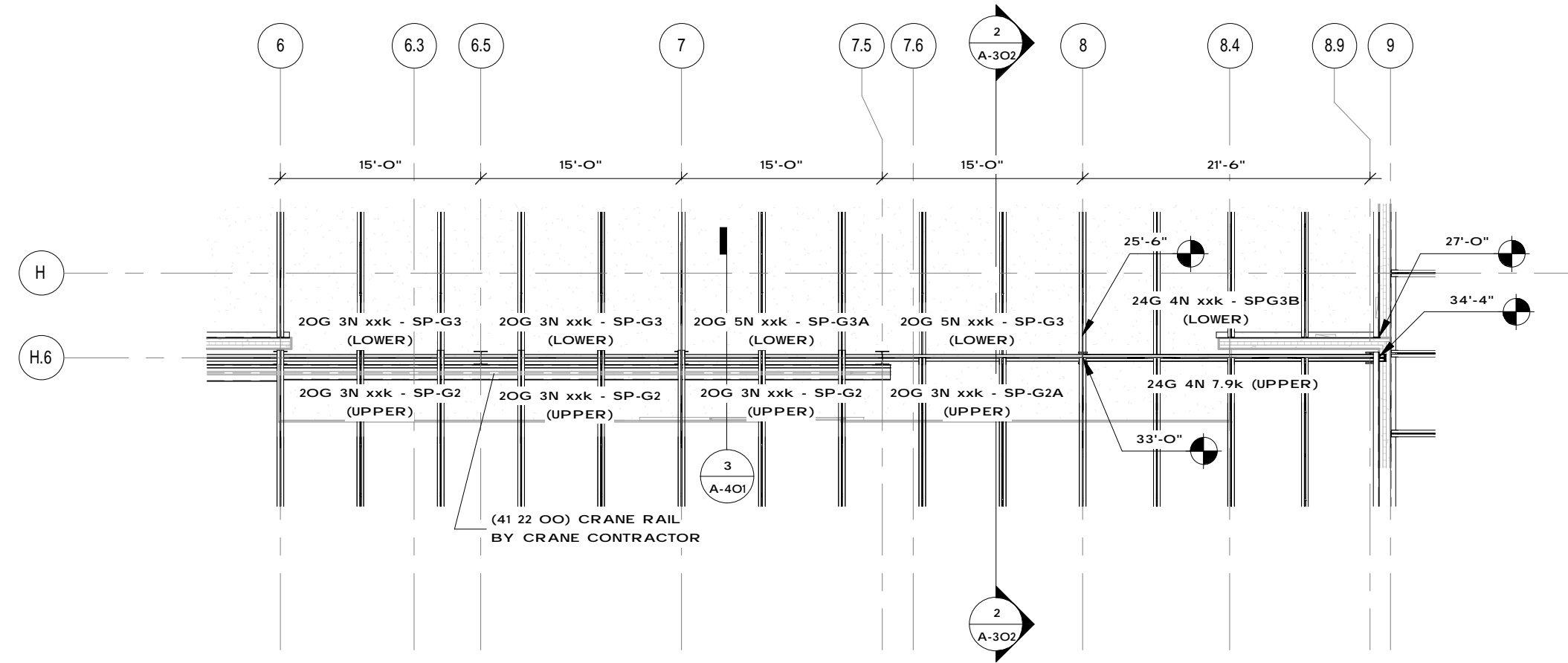

3 Girder Framing Above Mezz. Opening
3/32" = 1'-0"

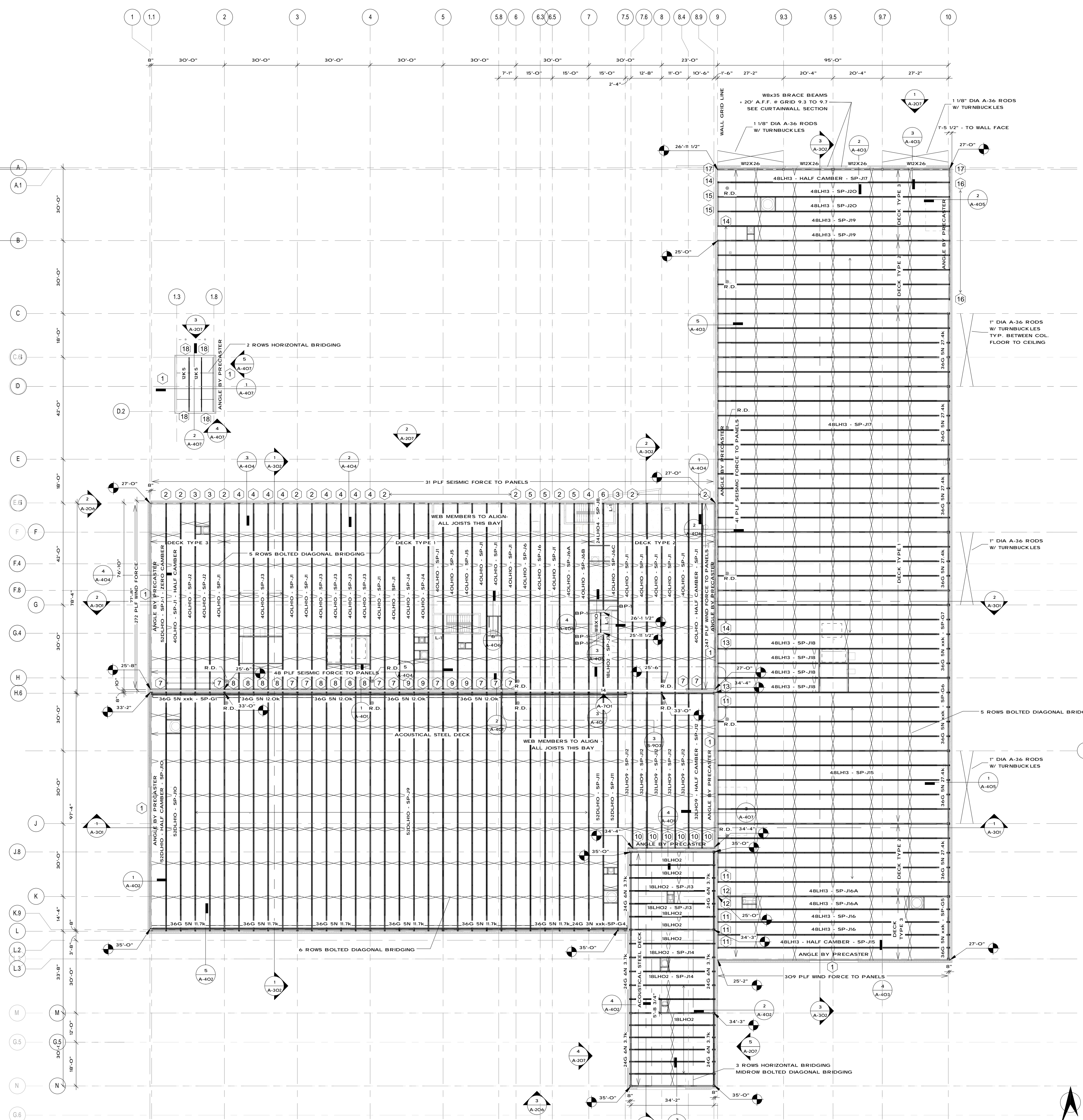

1 Roof Framing Plan
3/64" = 1'-0"



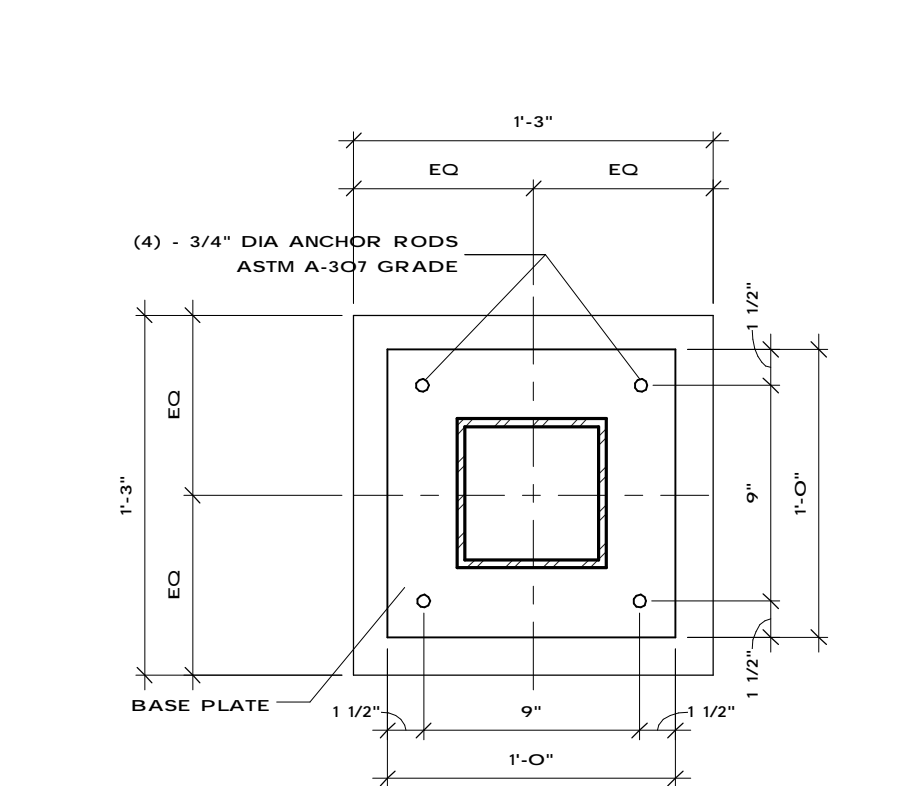
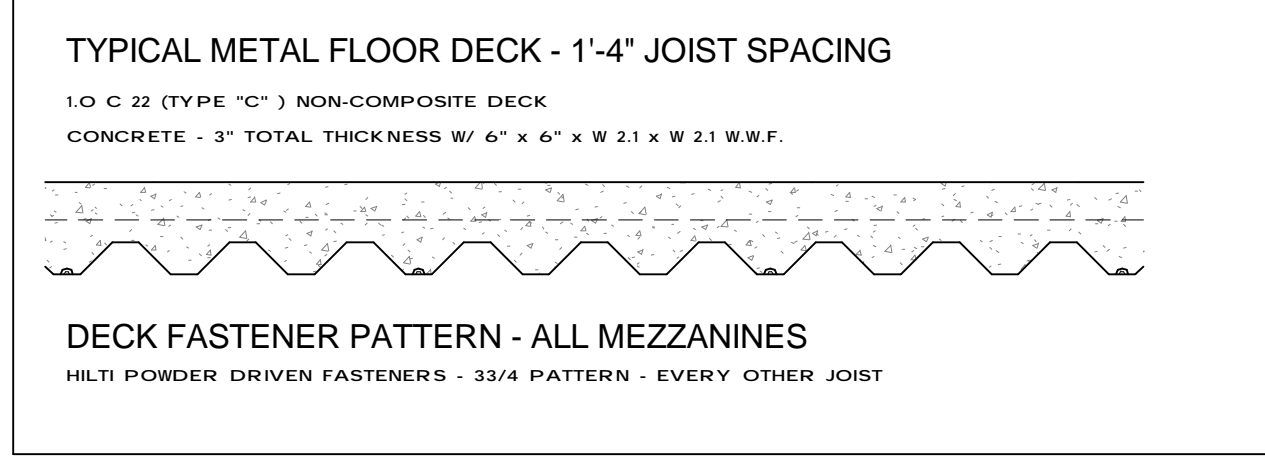
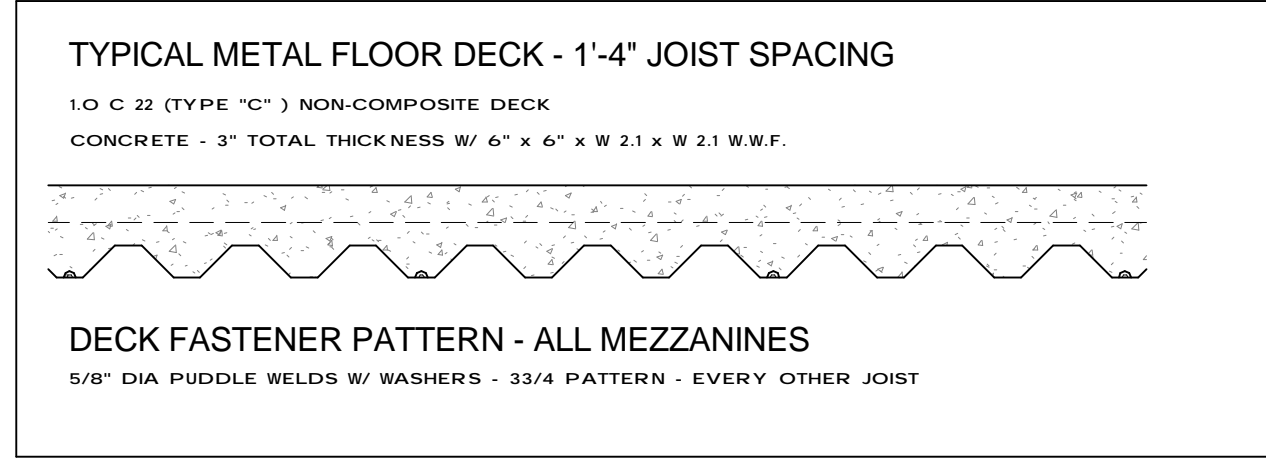
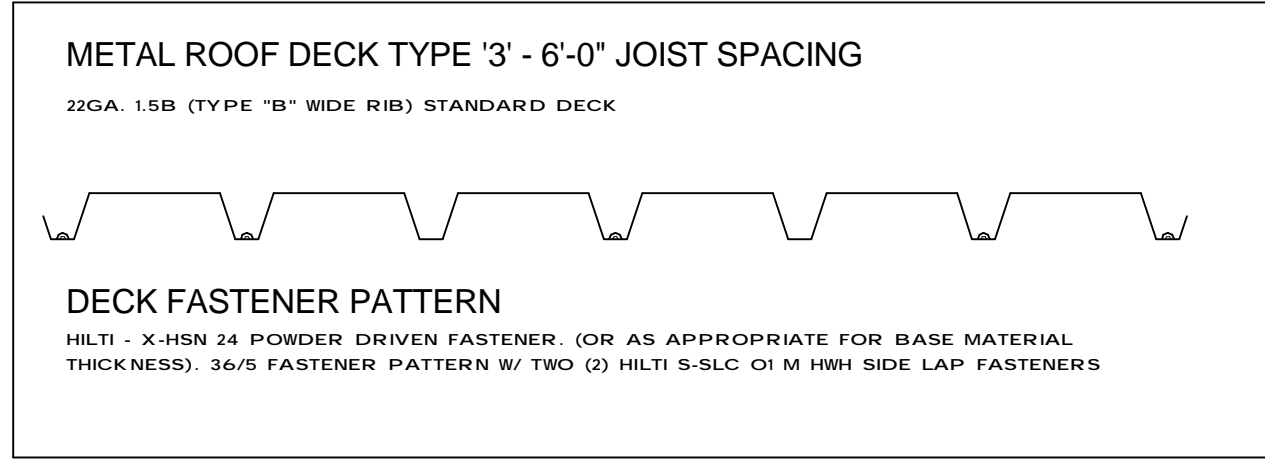
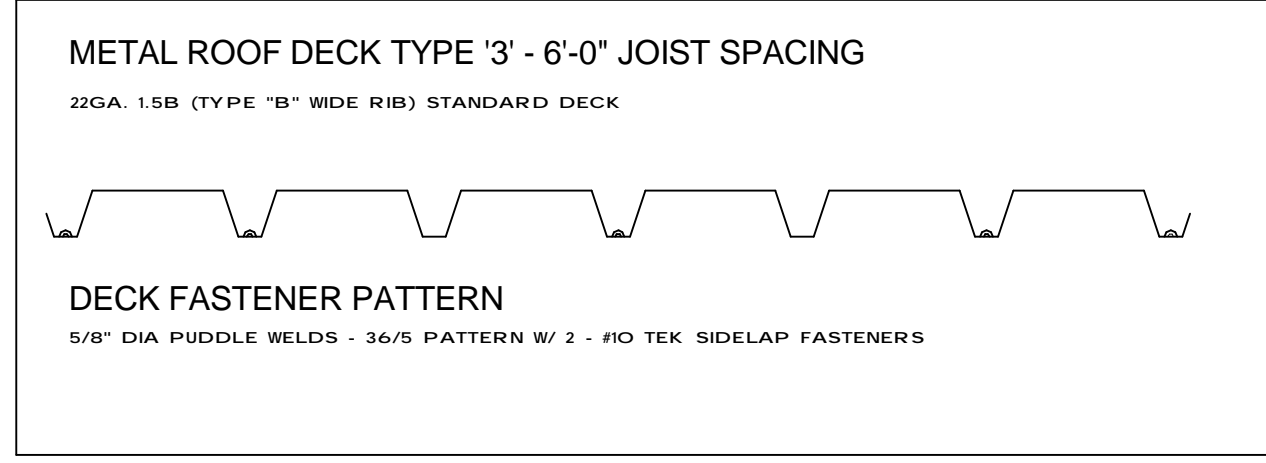
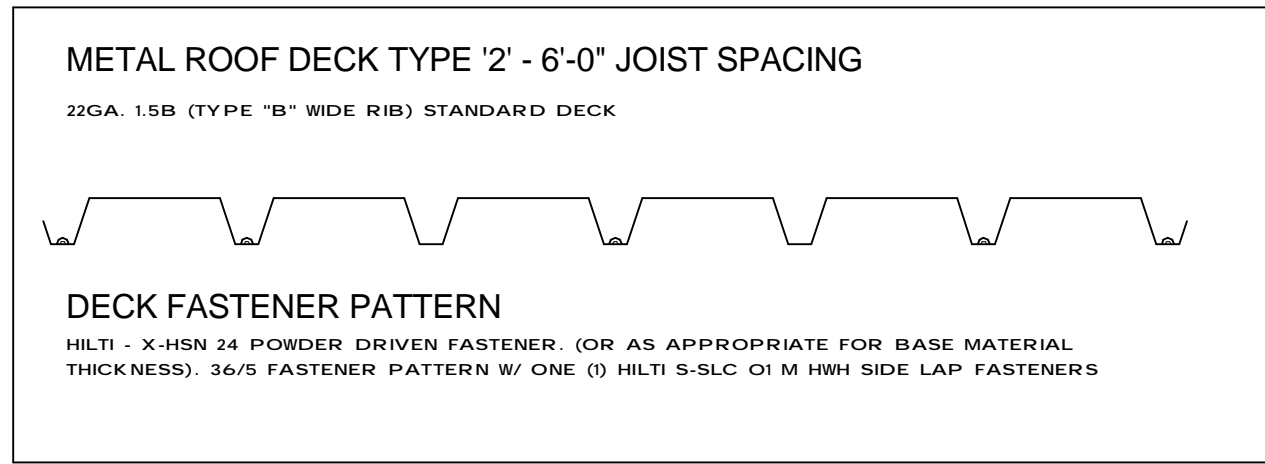
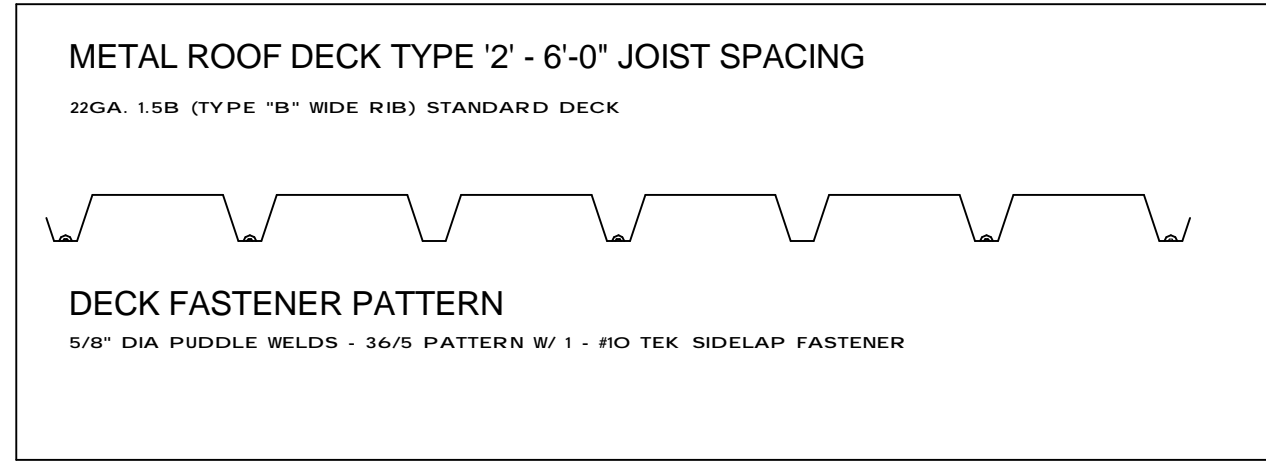
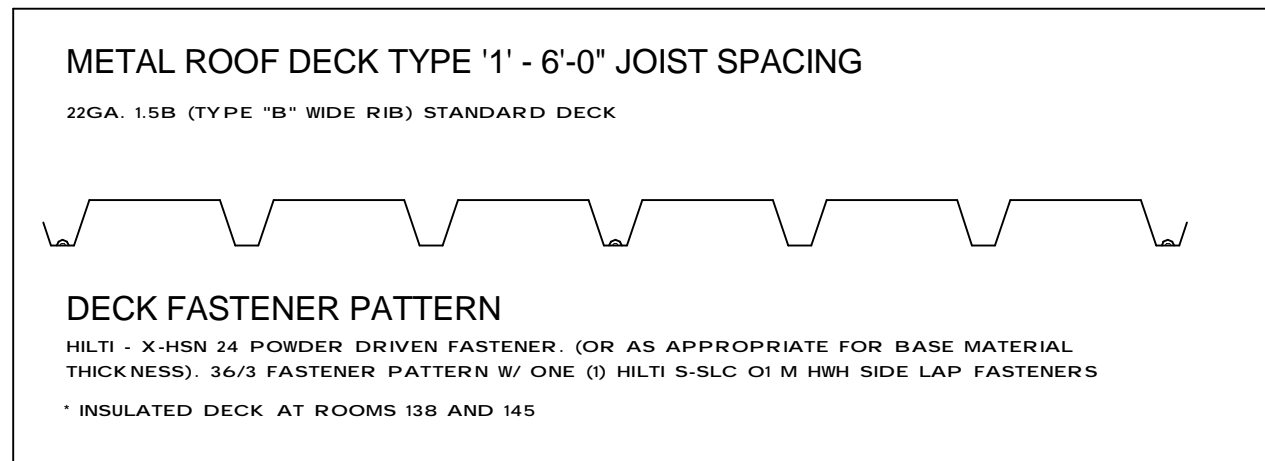
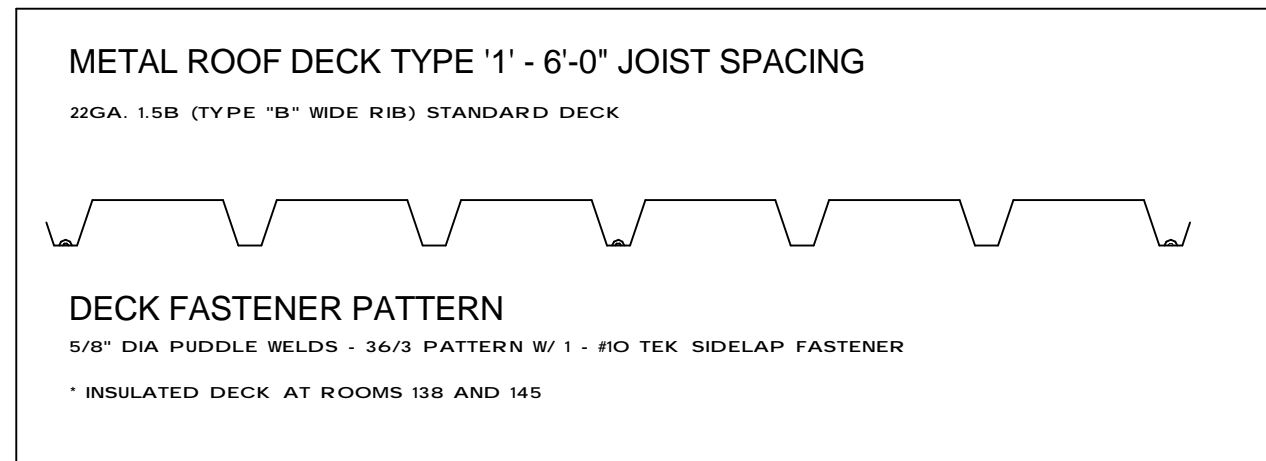

12 Base Plate - 6" HSS
1 1/2" = 1'-0"

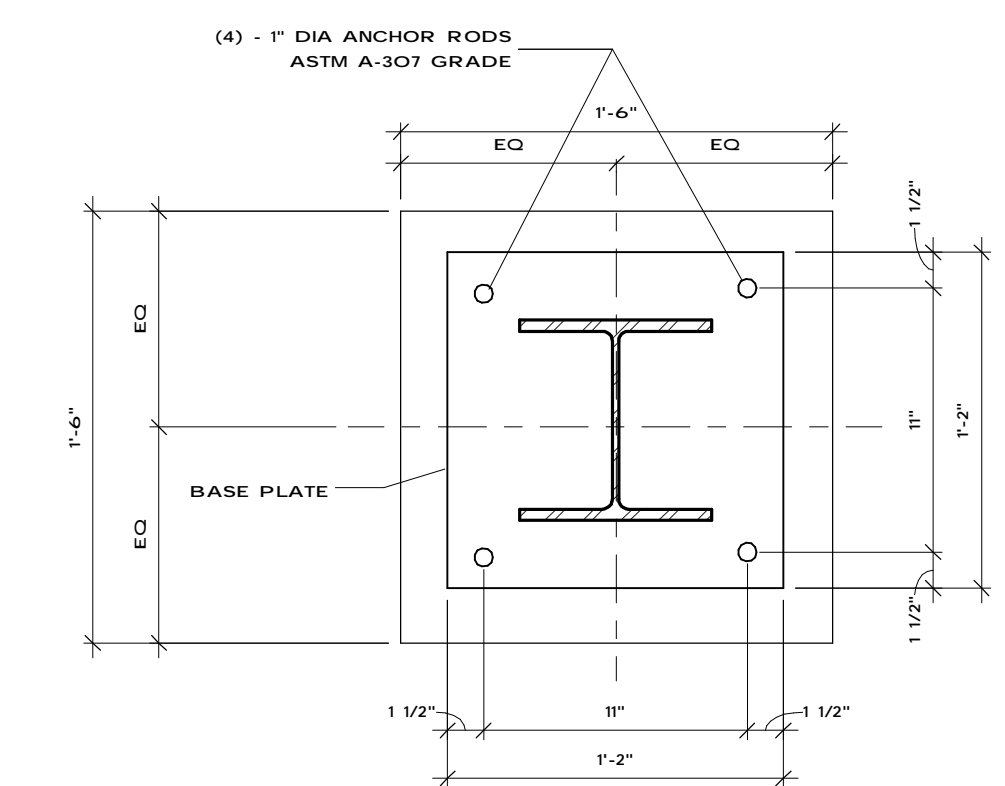

8 Base Plate - 8" Wide Flange
1 1/2" = 1'-0"

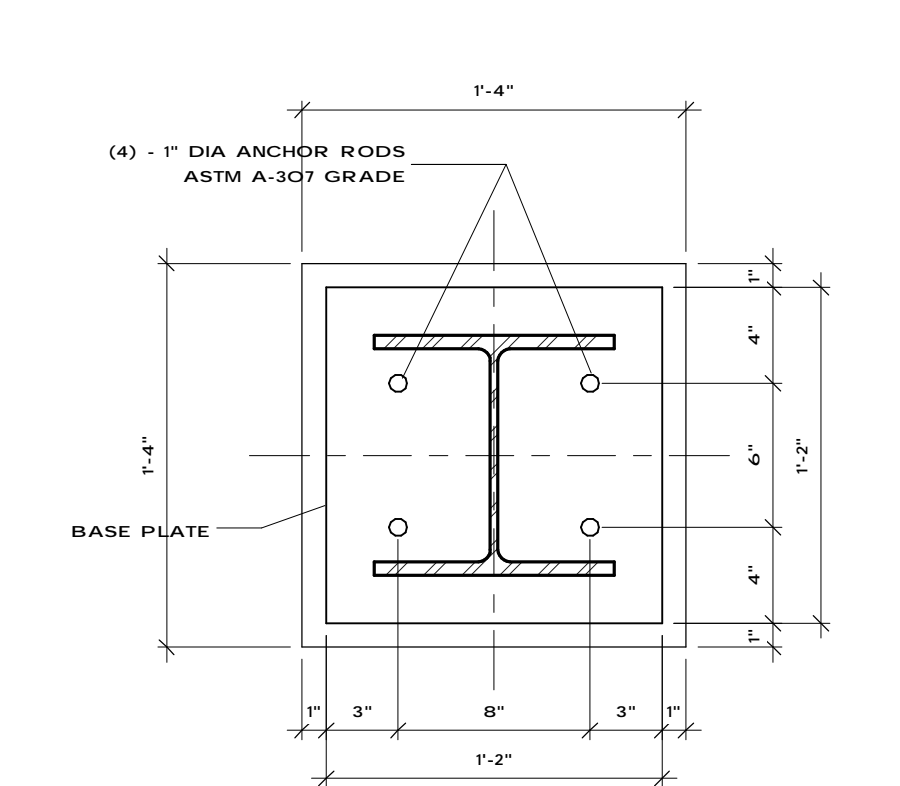

4 Base Plate - 10" Wide Flange
1 1/2" = 1'-0"

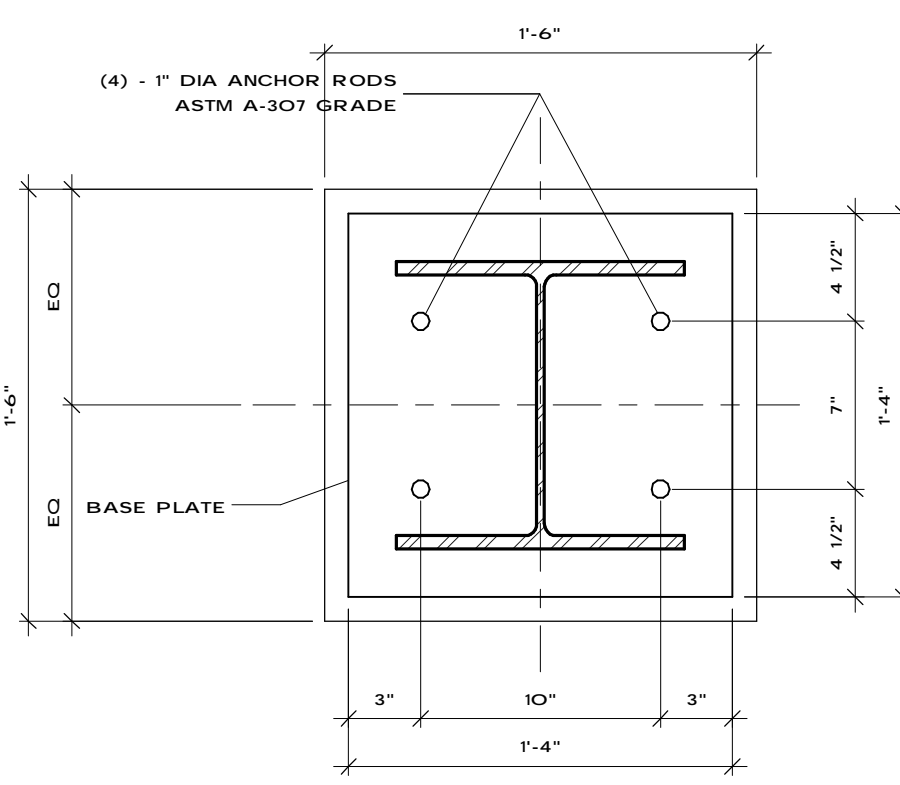

11 Base Plate - 12" Wide Flange
1 1/2" = 1'-0"

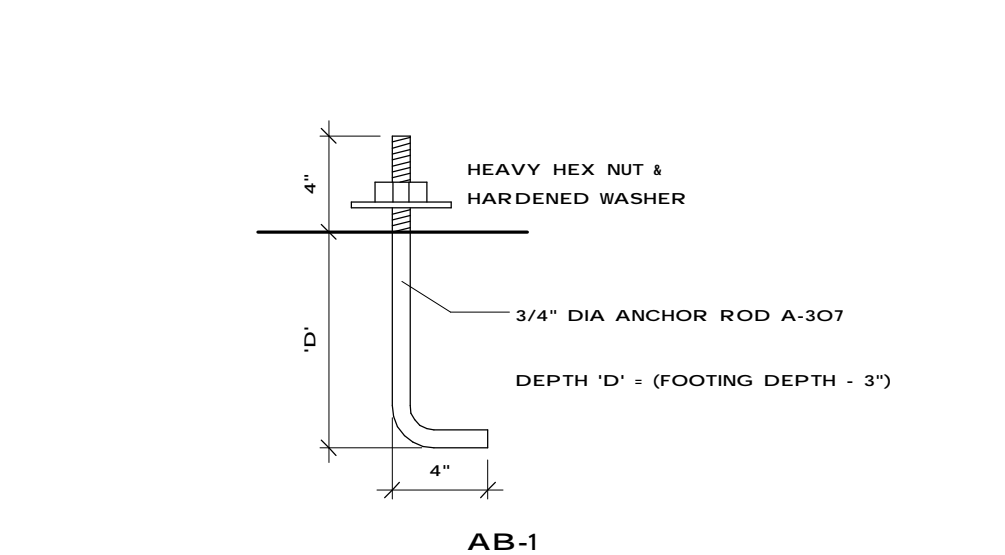

7 Anchor Rods
1 1/2" = 1'-0"

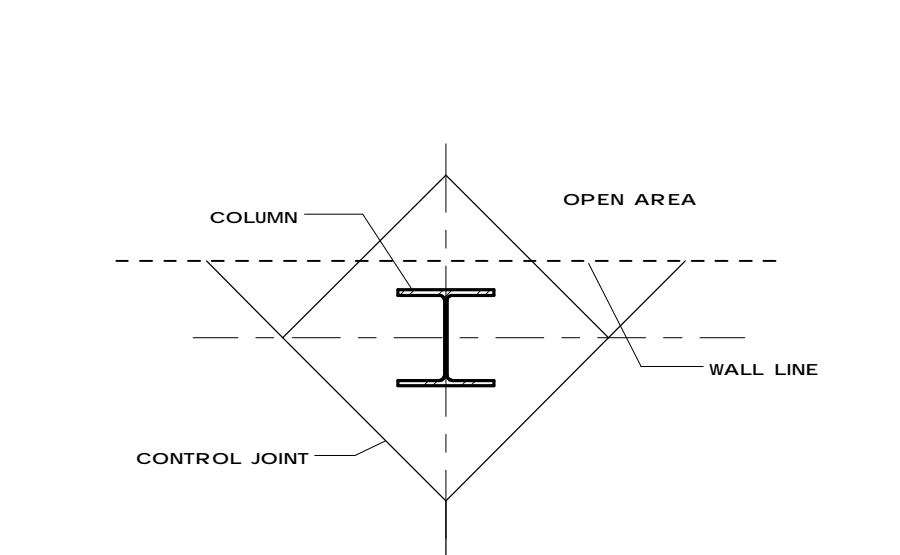

3 Column Control Joint
1/2" = 1'-0"

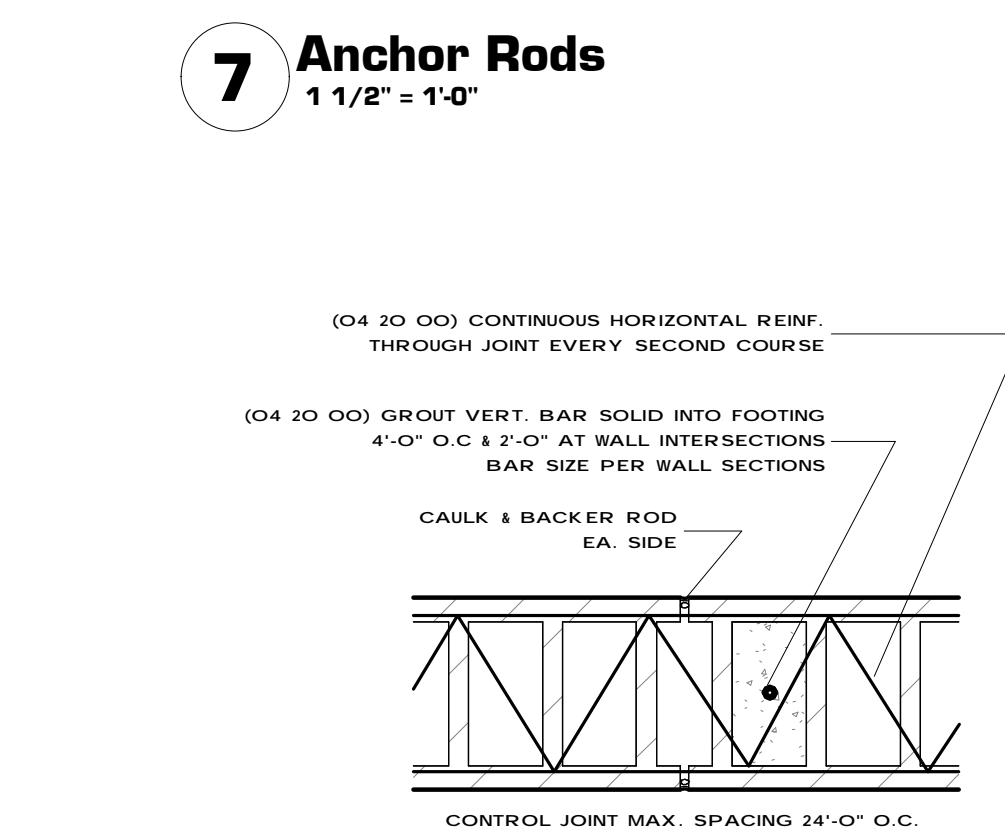

6 Masonry Control Joint
1 1/2" = 1'-0"

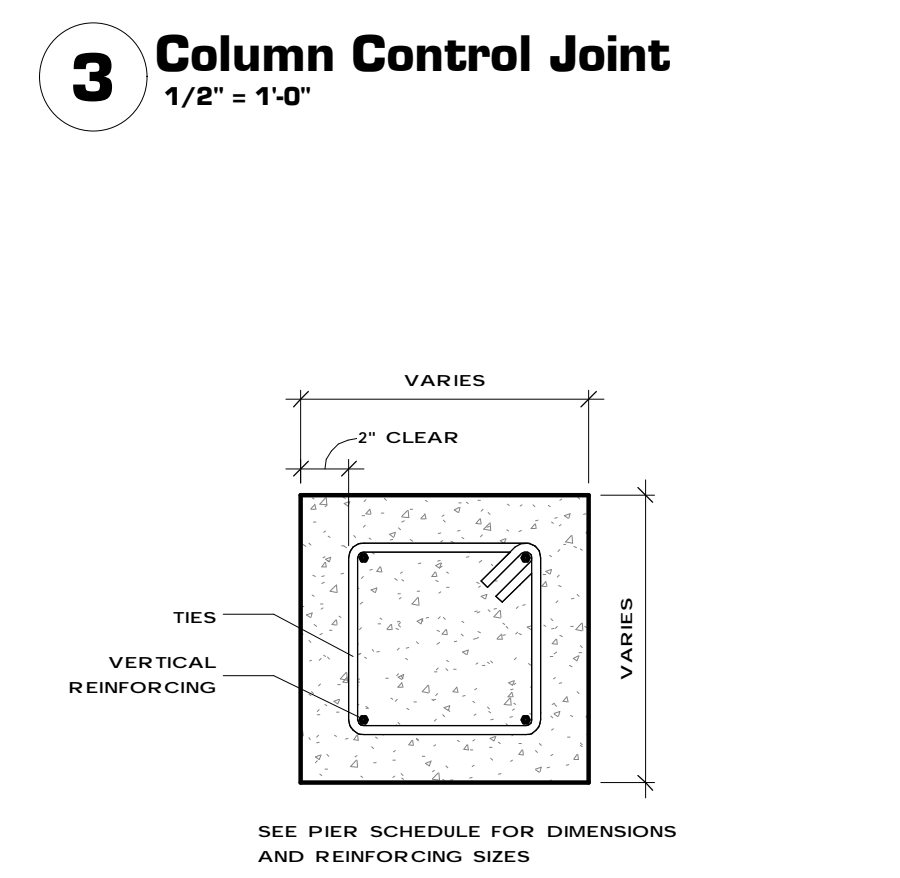

2 Pier Reinforcing Detail
1 1/2" = 1'-0"

Metal Deck Fastening - Puddle Welds

ROOF LOAD SYSTEM @ METAL DECK & JOISTS	
LIVE LOAD	21 P.S.F.
DEAD LOAD	15 P.S.F.
ROOF (ADHERED)	1.4
METAL DECK	1.8
INSULATION	1.6
SOLAR PANEL SYSTEM	5.0
MECHANICAL	2.0
MISCELLANEOUS	3.0
	14.8
DESIGN LOAD	36 P.S.F.

FLOOR LOAD SYSTEM @ 12" HOLLOWCORE DECK (LIGHT STORAGE)	
LIVE LOAD	125 P.S.F.
STORAGE LOADING	125.0
PARTITIONS	0.0
	125.0
DEAD LOAD	122 P.S.F.
2" TOPPING	37.5
12" HOLLOWCORE PRECAST	79.0
MECHANICAL	2.0
MISCELLANEOUS	3.0
	121.5
DESIGN LOAD	247 P.S.F.

FLOOR LOAD SYSTEM @ 3" CONCRETE / DECK (LIGHT STORAGE)	
LIVE LOAD	125 P.S.F.
STORAGE LOADING	125.0
PARTITIONS	0.0
	125.0
DEAD LOAD	36 P.S.F.
NON COMPOSITE DECK (3")	31.0
MECHANICAL	2.0
MISCELLANEOUS	3.0
	36.0
DESIGN LOAD	161 P.S.F.

Metal Deck Fastening - Hilti Fasteners

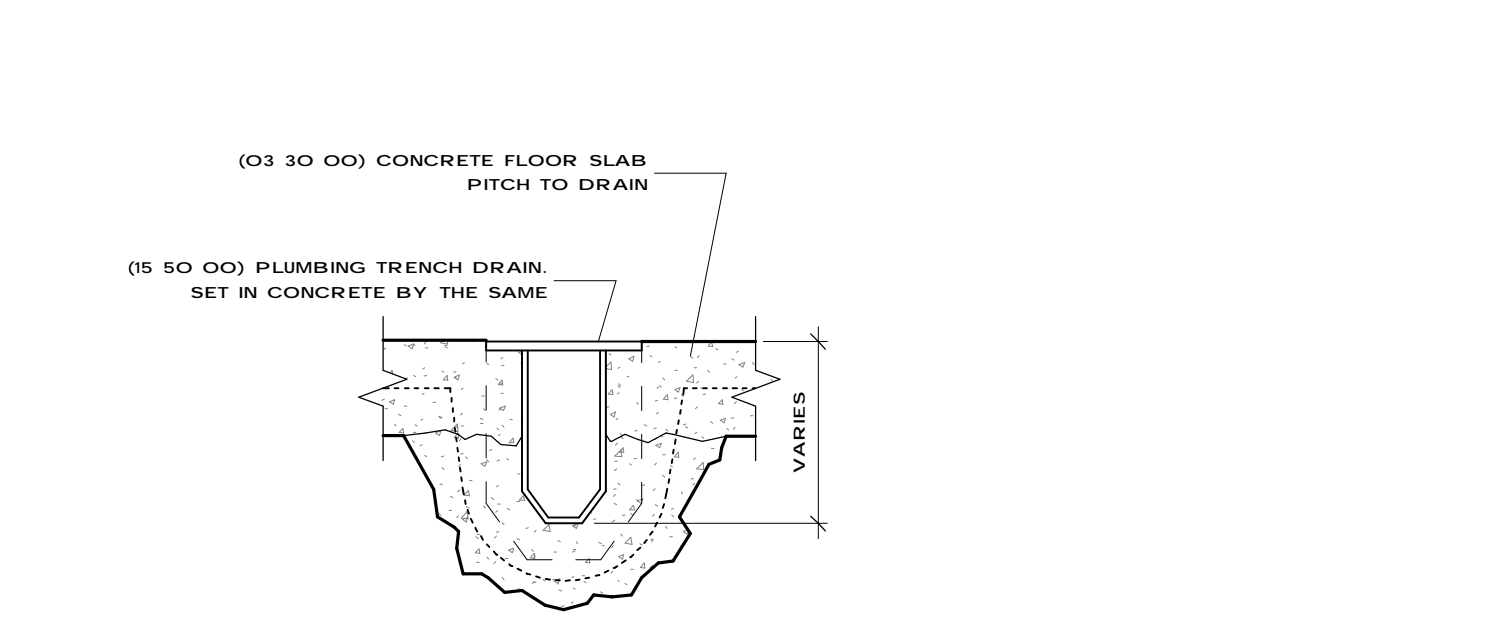

14 Trench Drain - Small
1 1/2" = 1'-0"

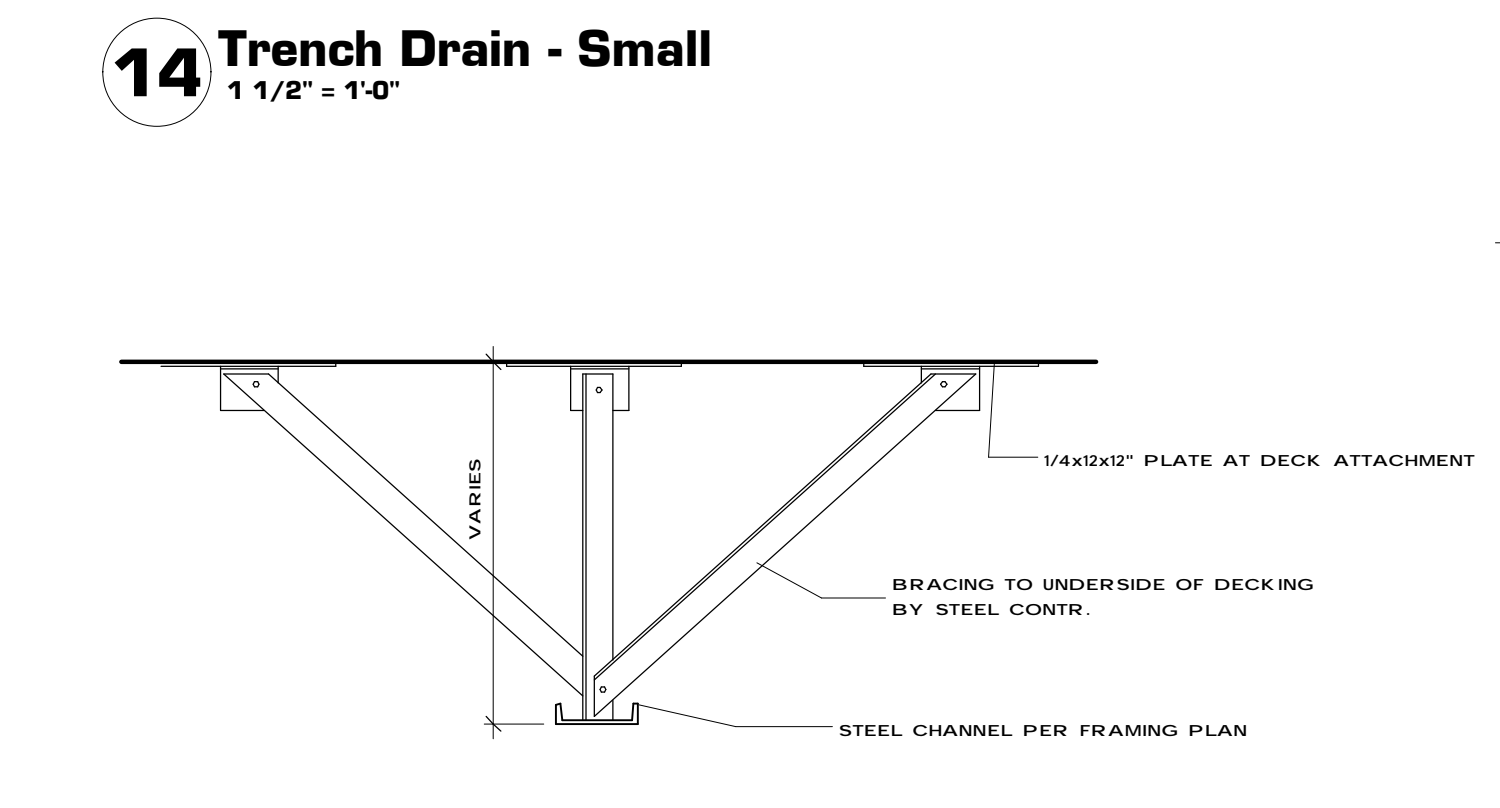

13 Toilet Partition Support
3/4" = 1'-0"

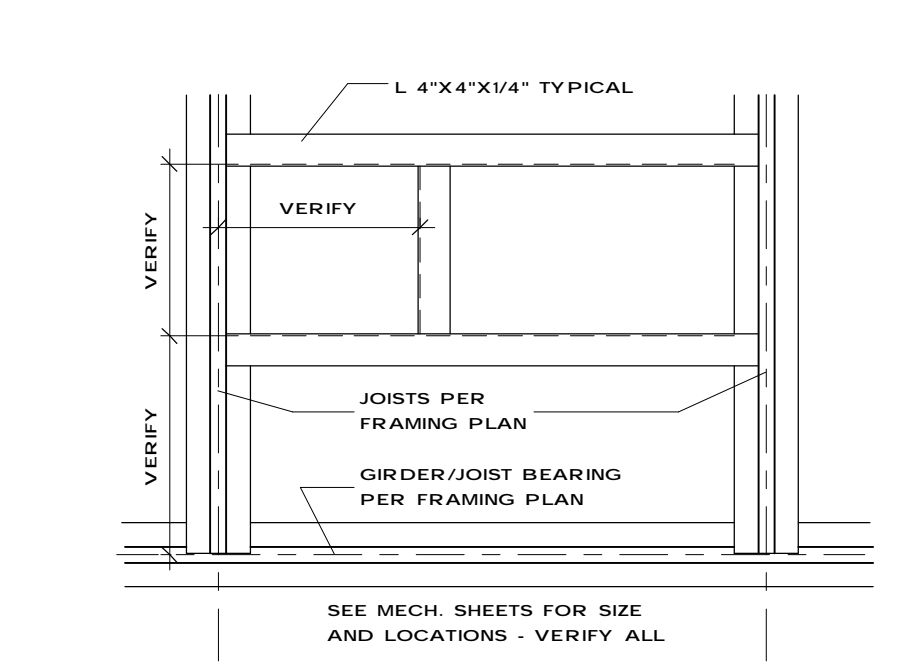

10 Framing @ All Roof Opening
1/2" = 1'-0"

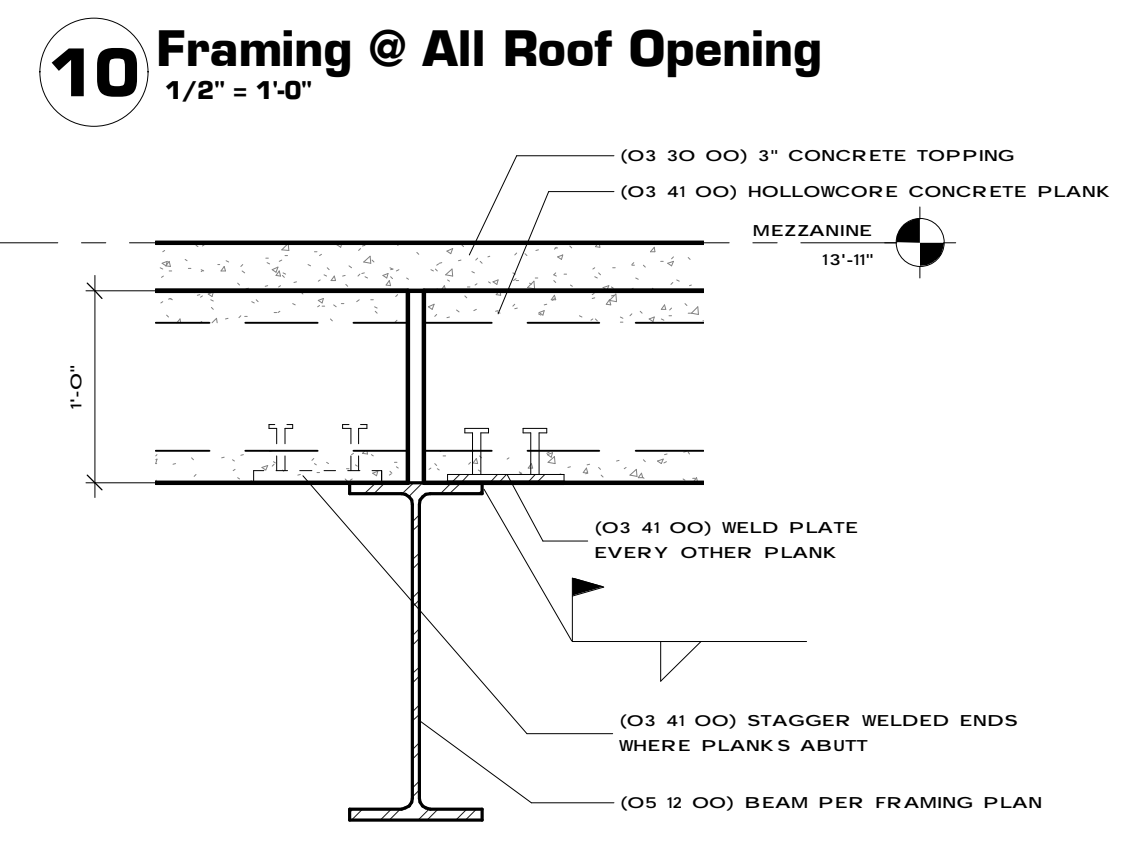

9 Plank Bearing
1" = 1'-0"

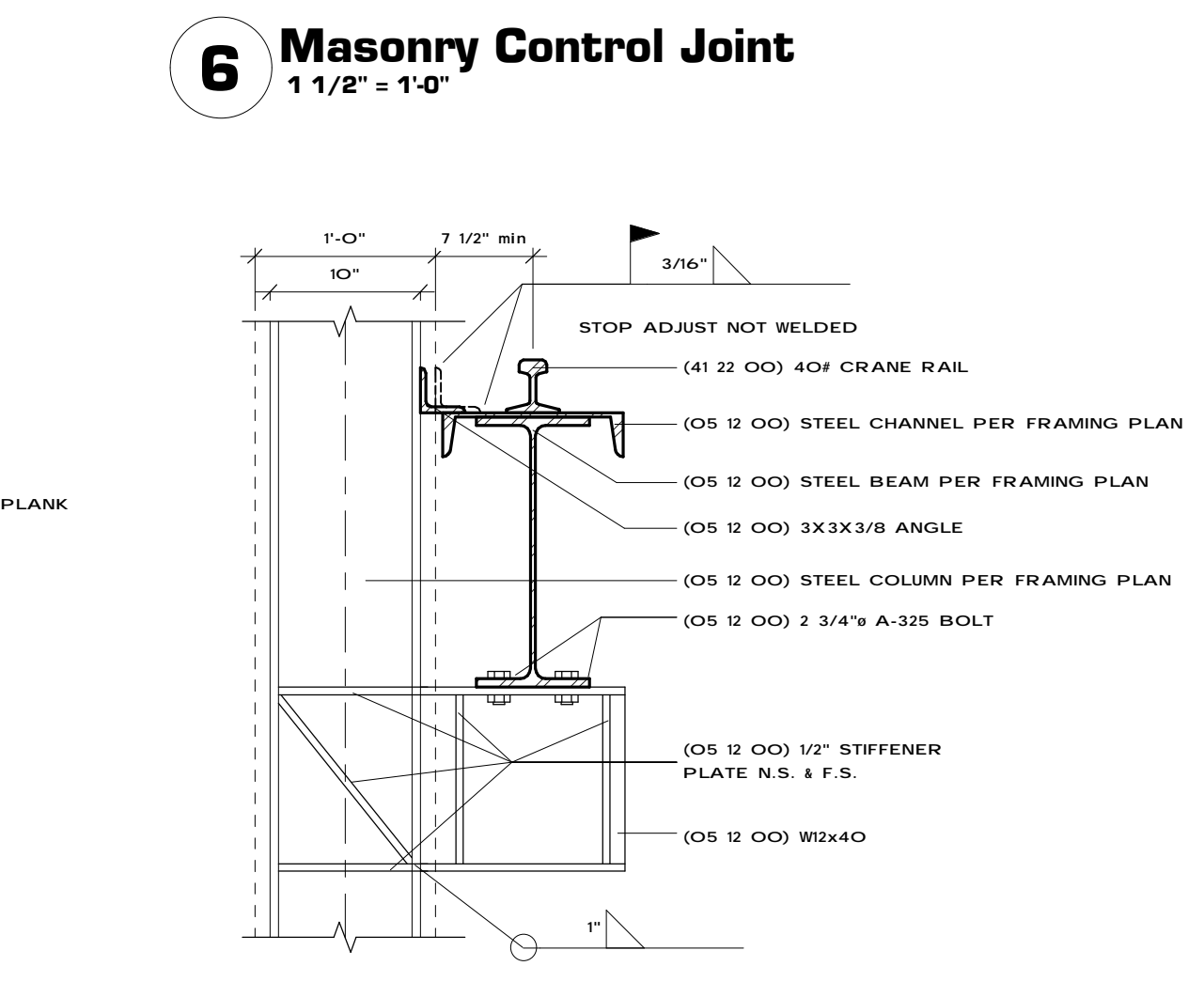

5 Crane Beam Haunch
1" = 1'-0"

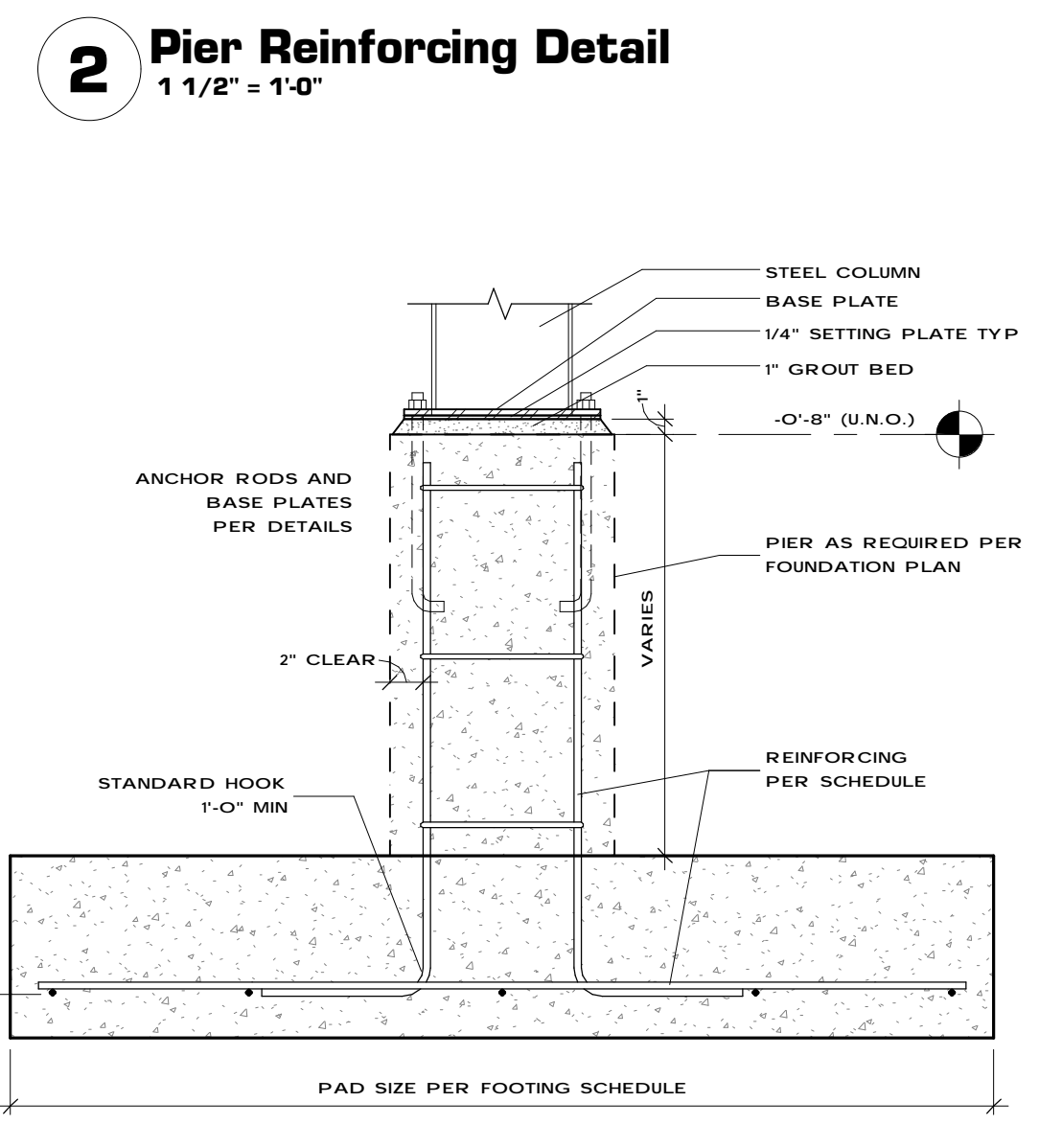

1 Pad Footing - Typ.
1" = 1'-0"

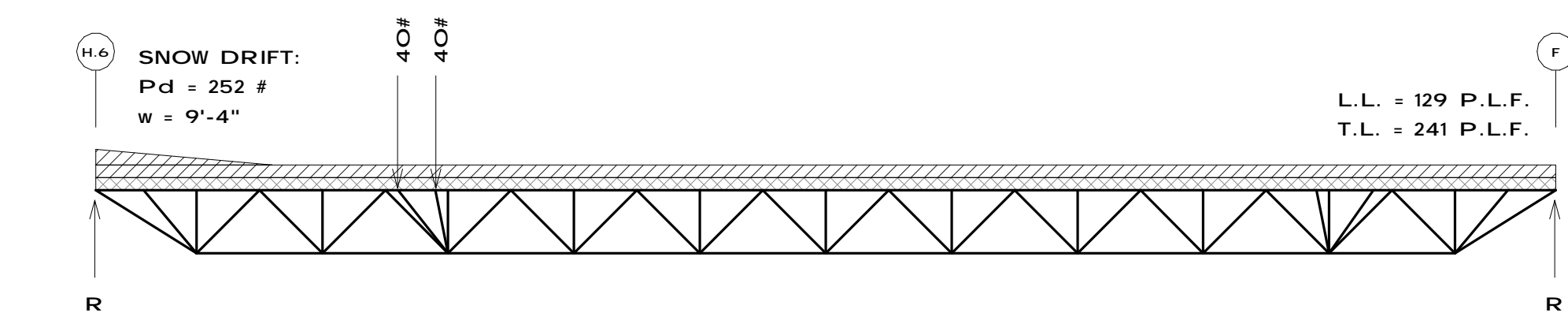

22 SP-J5
1/8" = 1'-0"

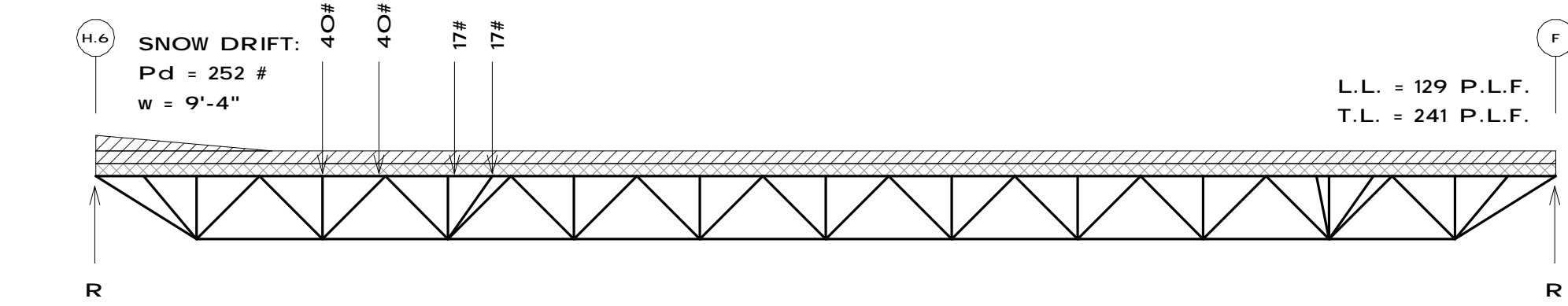

21 SP-J4
1/8" = 1'-0"

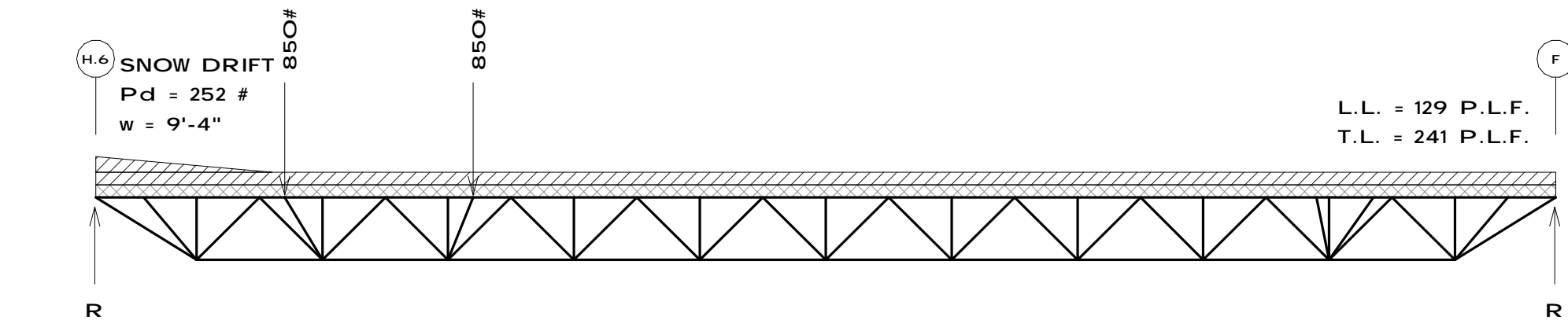

20 SP-J3
1/8" = 1'-0"

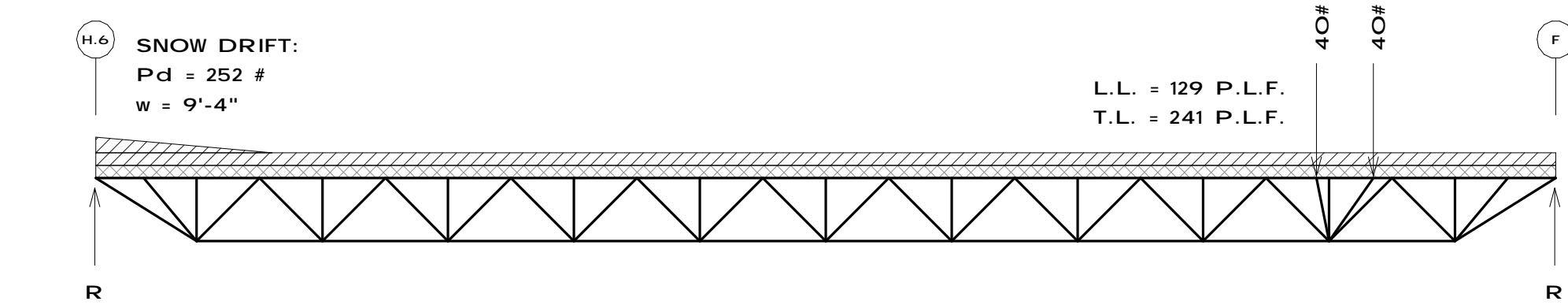

19 SP-J2
1/8" = 1'-0"

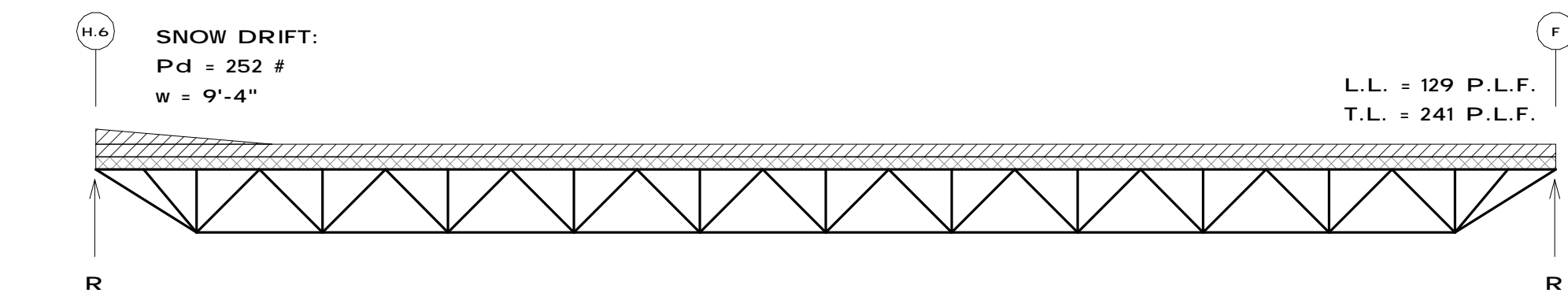

18 SP-J1
1/8" = 1'-0"

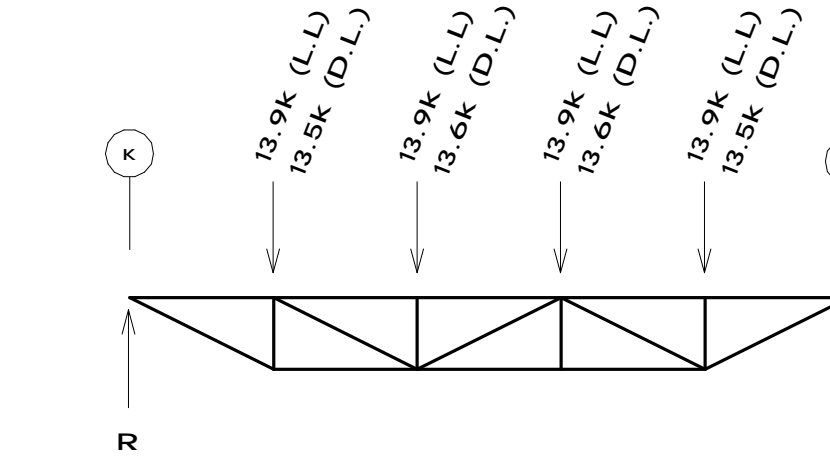

15 SP-G12
1/8" = 1'-0"

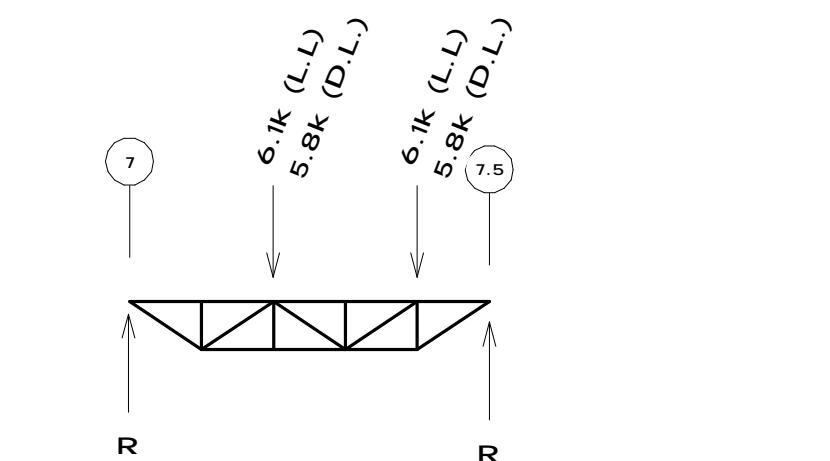

14 SP-G11
1/8" = 1'-0"

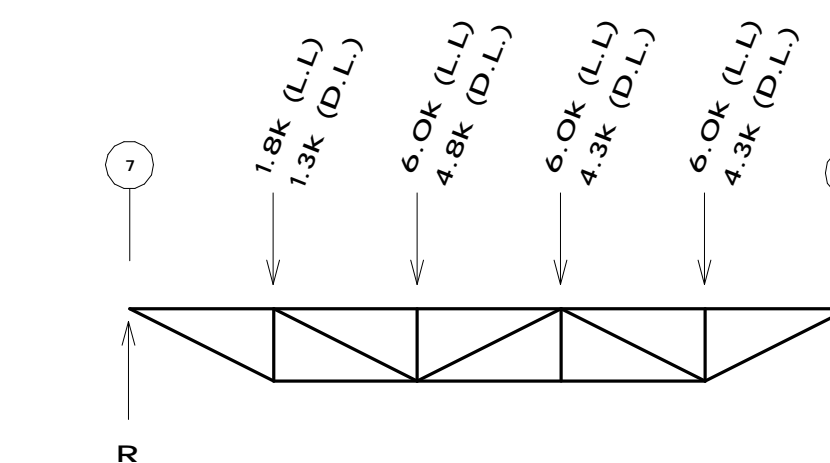

13 SP-G10
1/8" = 1'-0"

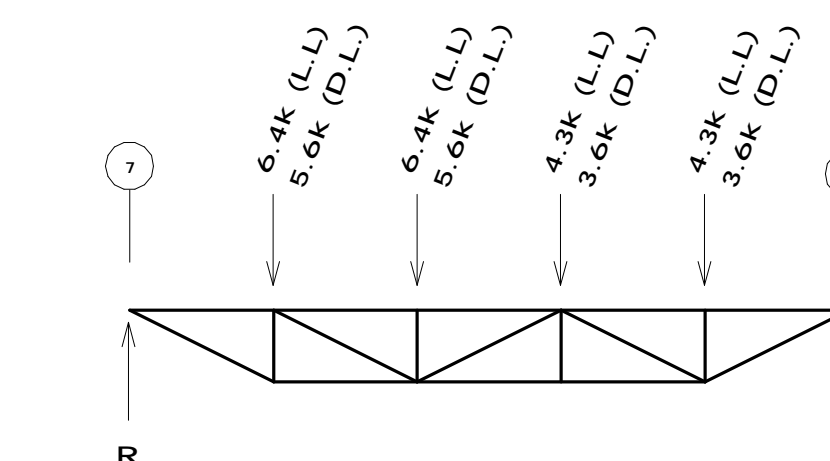

12 SP-G9
1/8" = 1'-0"

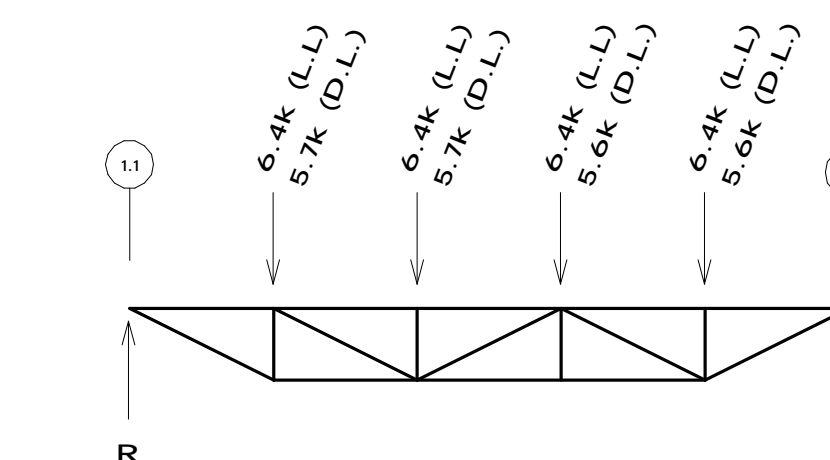

11 SP-G8
1/8" = 1'-0"

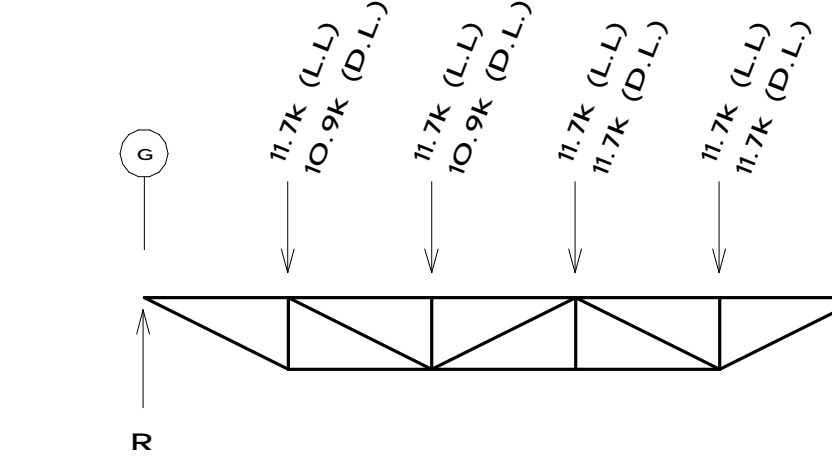

10 SP-G7
1/8" = 1'-0"

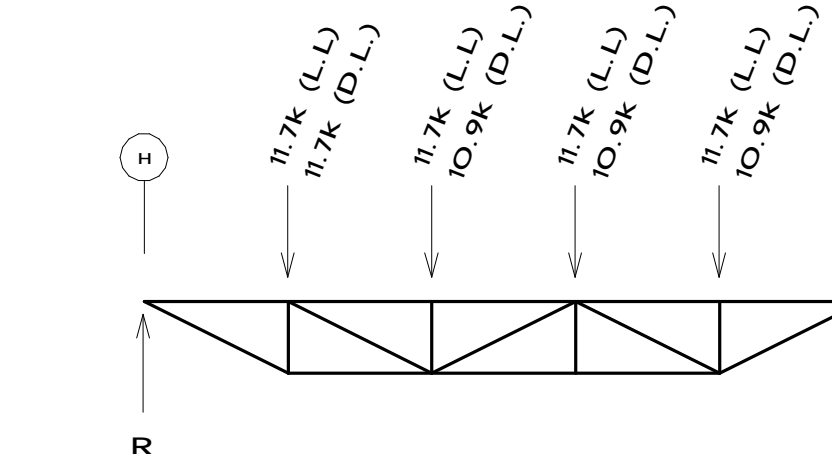

9 SP-G6
1/8" = 1'-0"

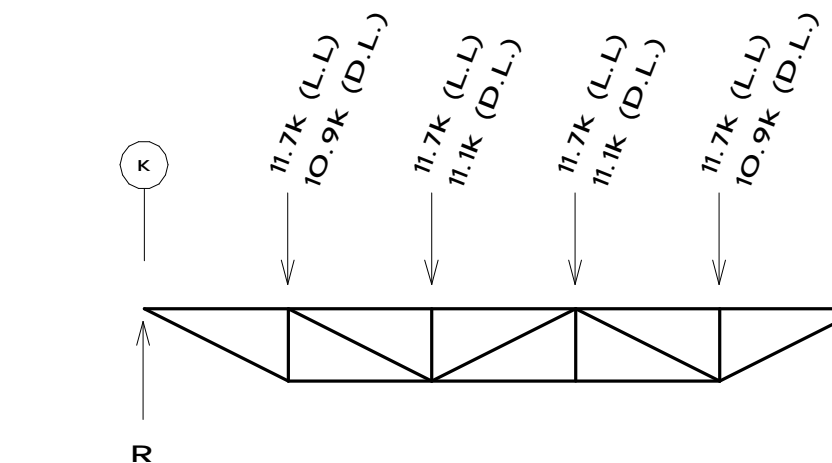

8 SP-G5
1/8" = 1'-0"

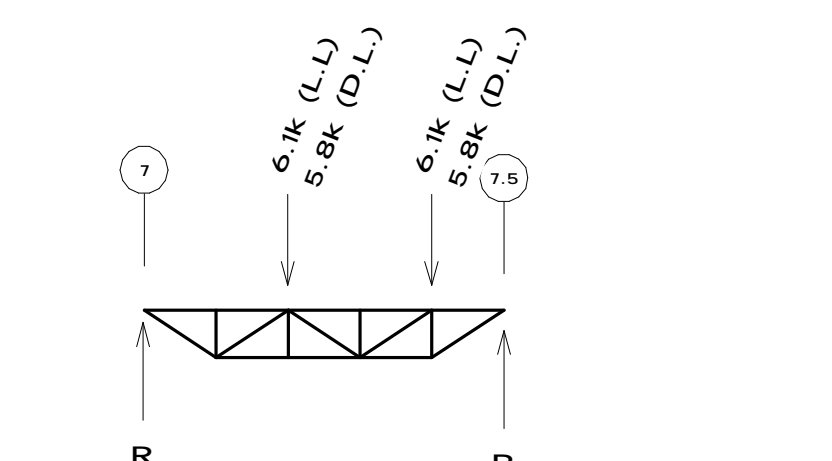

7 SP-G4
1/8" = 1'-0"

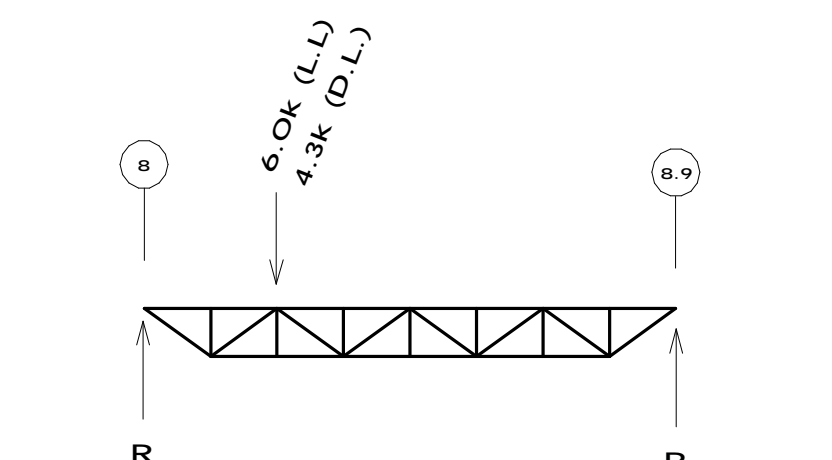

6 SP-G3B
1/8" = 1'-0"

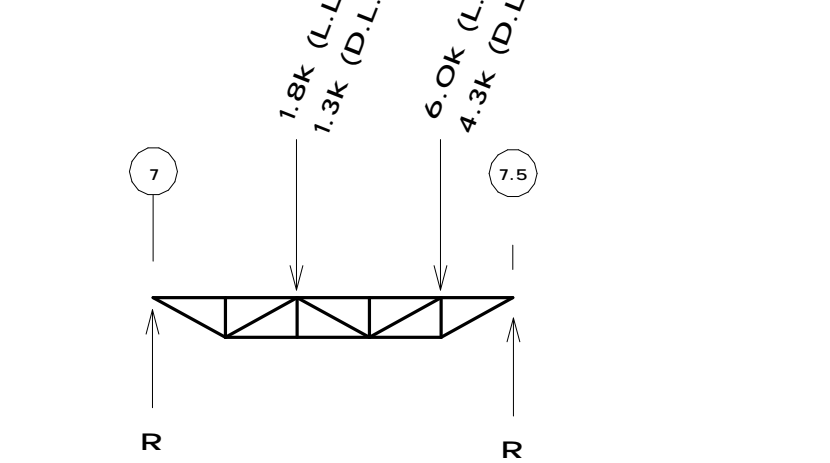

5 SP-G3A
1/8" = 1'-0"

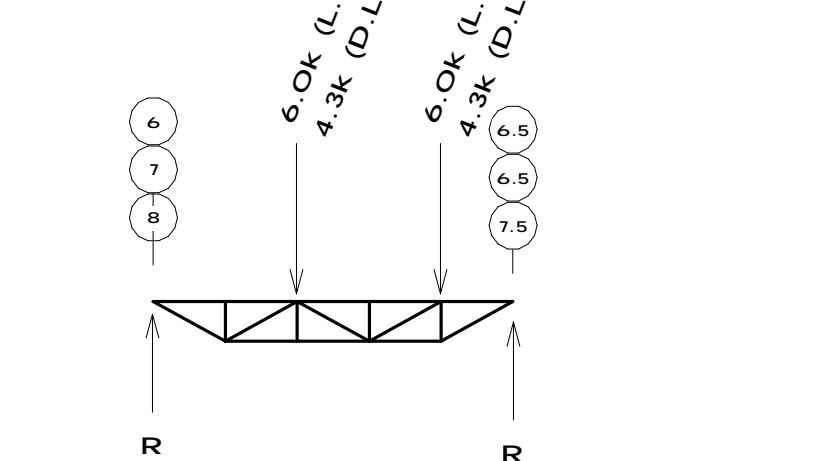

4 SP-G3
1/8" = 1'-0"

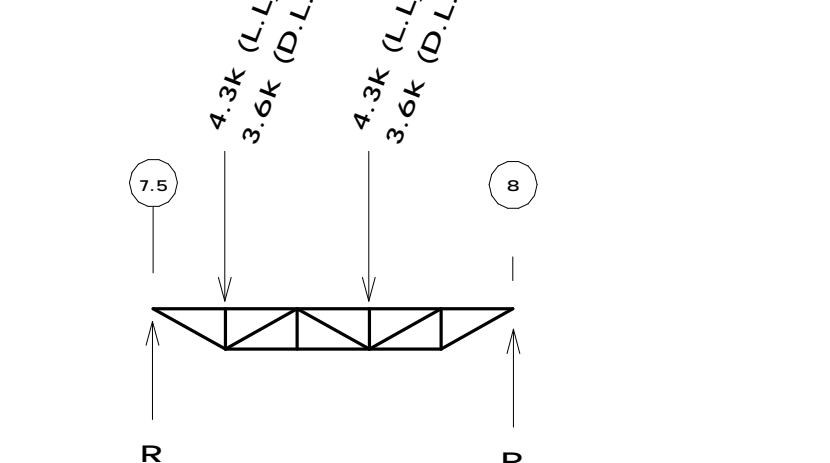

3 SP-G2A
1/8" = 1'-0"

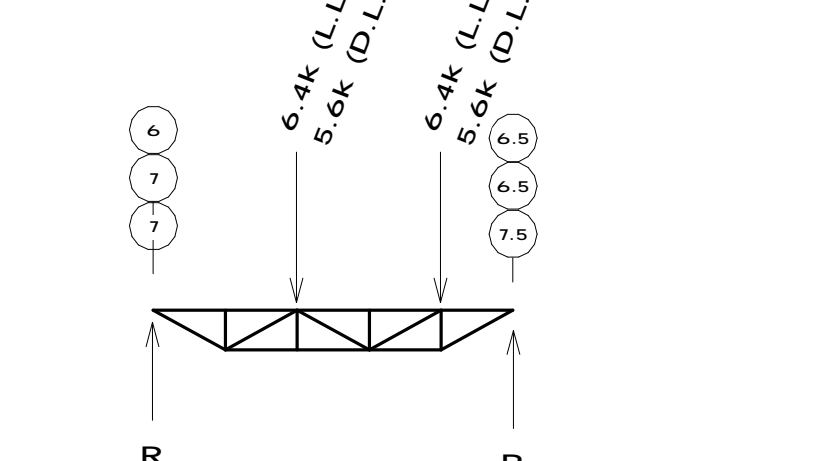

2 SP-G2
1/8" = 1'-0"

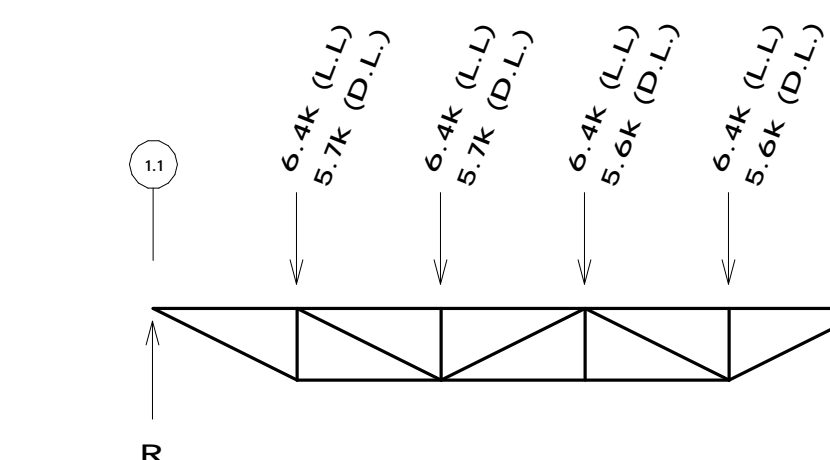

1 SP-G1
1/8" = 1'-0"

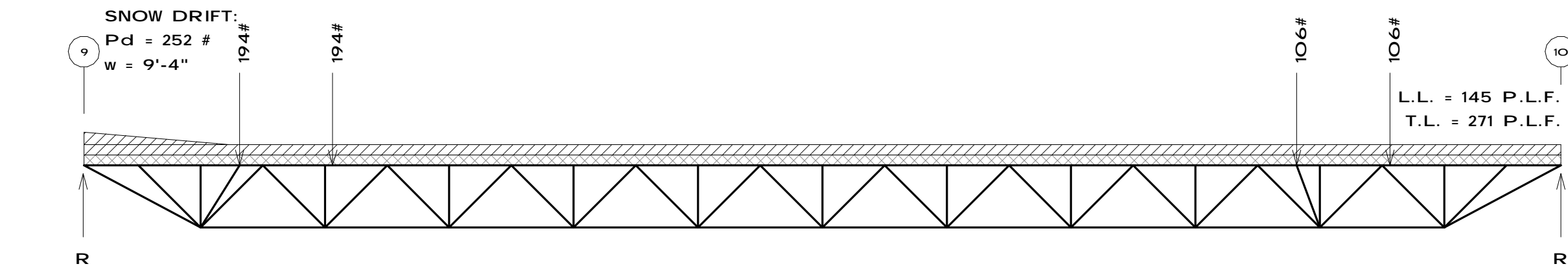

14 SP-J16
1/8" = 1'-0"

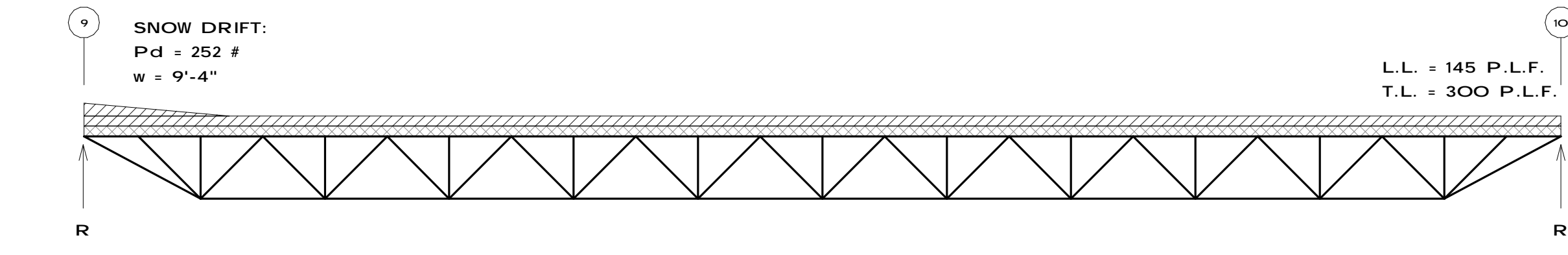

13 SP-J15
1/8" = 1'-0"

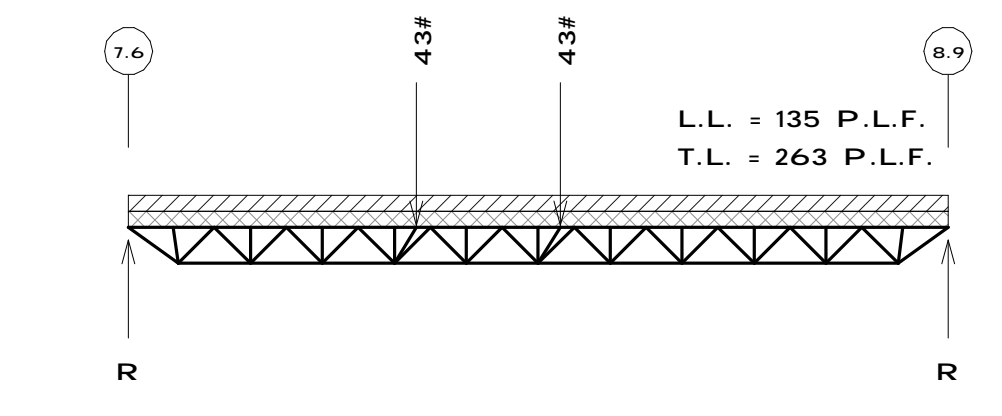

12 SP-J14
1/8" = 1'-0"

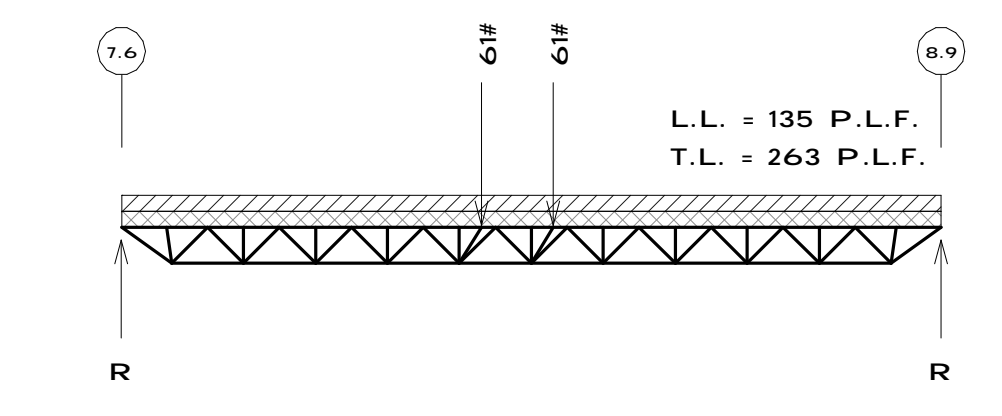

11 SP-J13
1/8" = 1'-0"

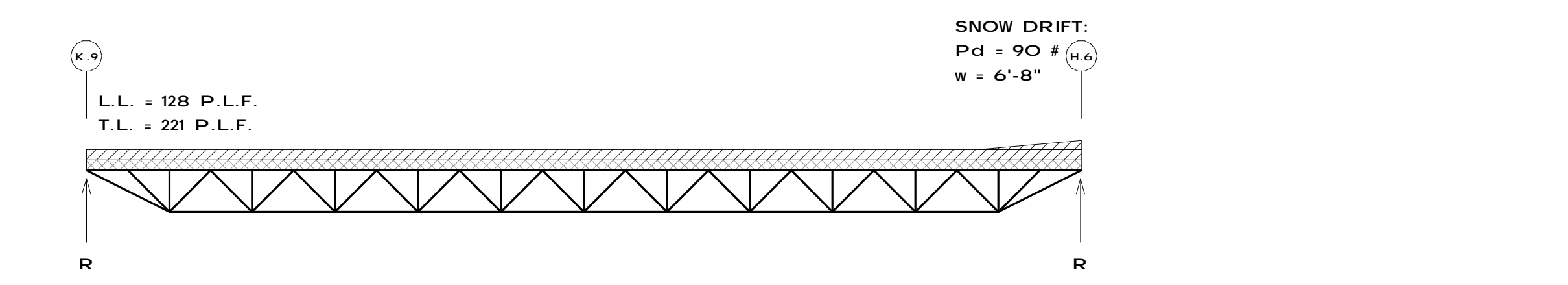

10 SP-J12
1/8" = 1'-0"

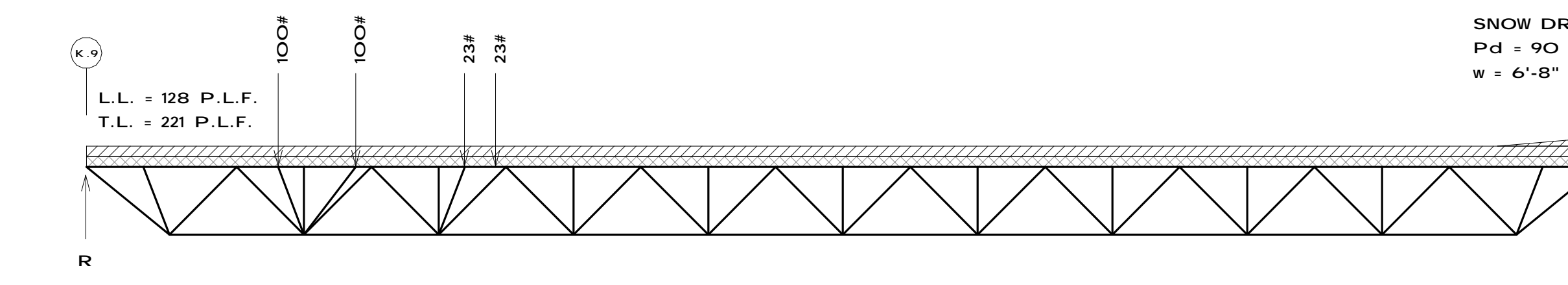

9 SP-J11
1/8" = 1'-0"

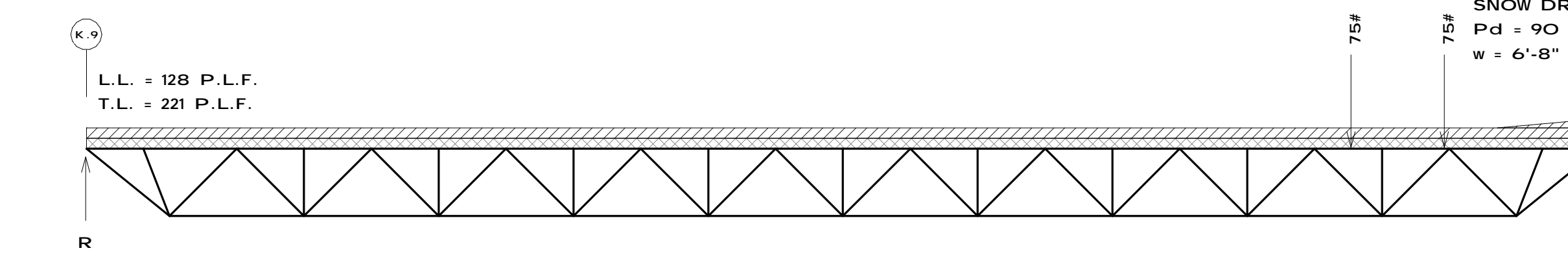

8 SP-J10
1/8" = 1'-0"

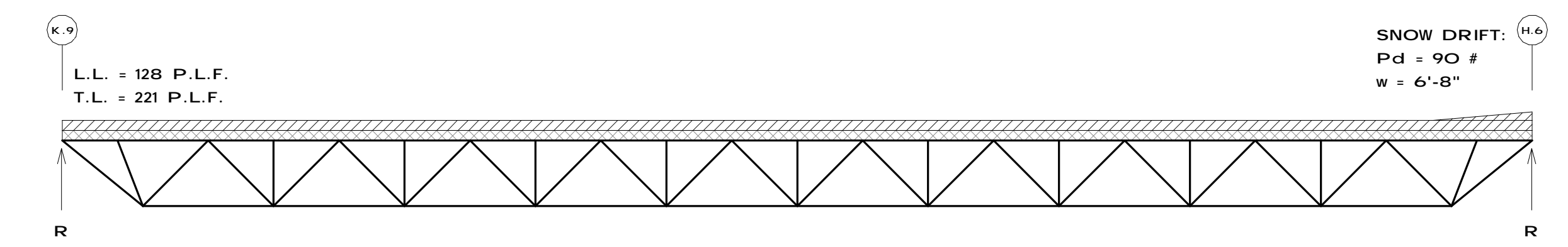

7 SP-J9
1/8" = 1'-0"

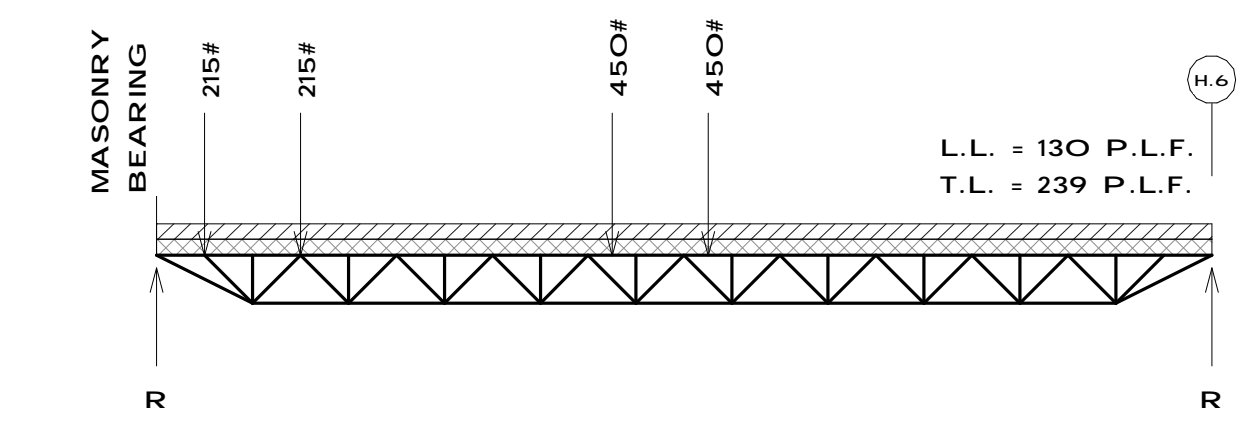

6 SP-J8
1/8" = 1'-0"

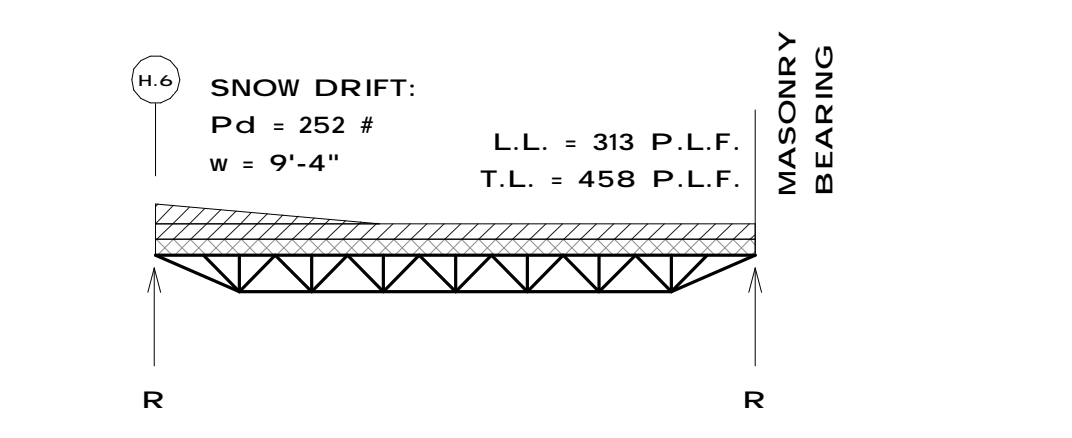

5 SP-J7
1/8" = 1'-0"

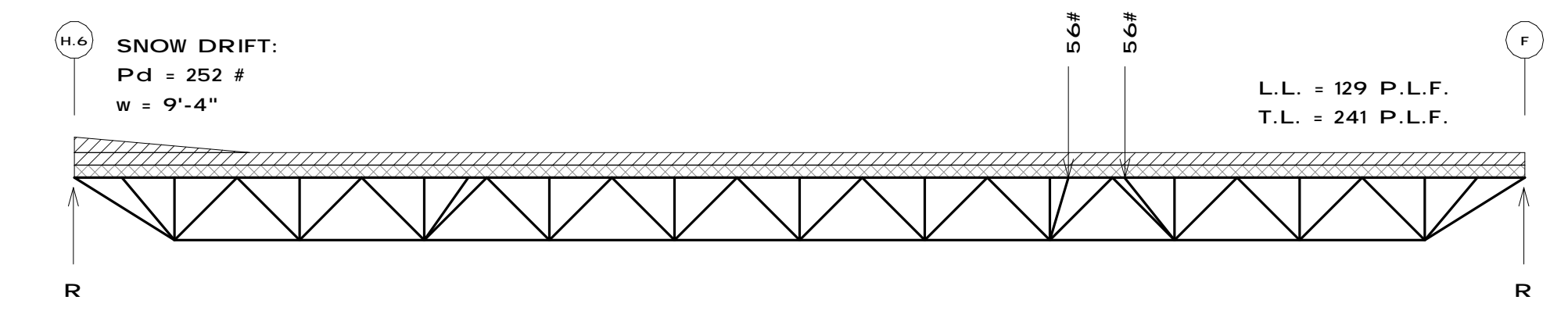

4 SP-J6C
1/8" = 1'-0"

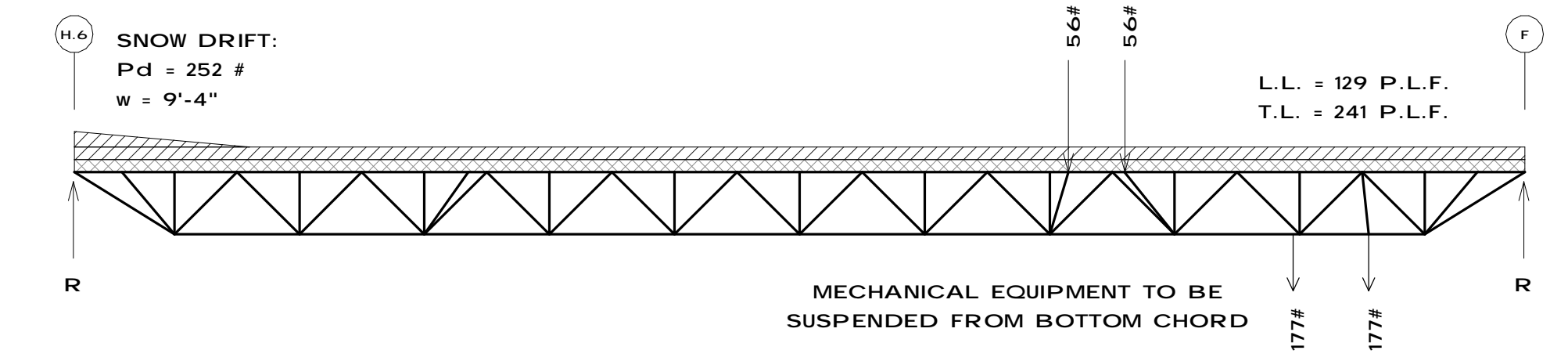

3 SP-J6B
1/8" = 1'-0"

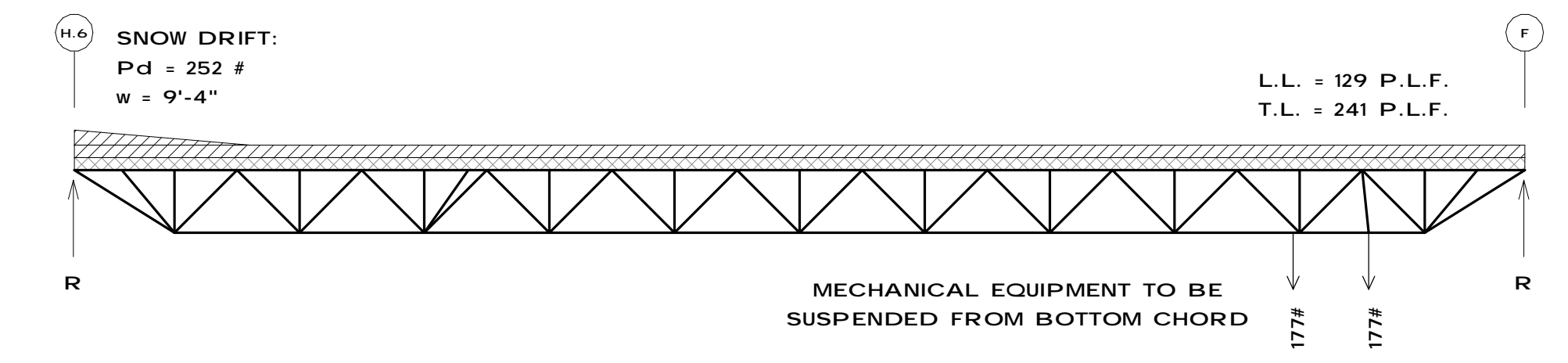

2 SP-J6A
1/8" = 1'-0"

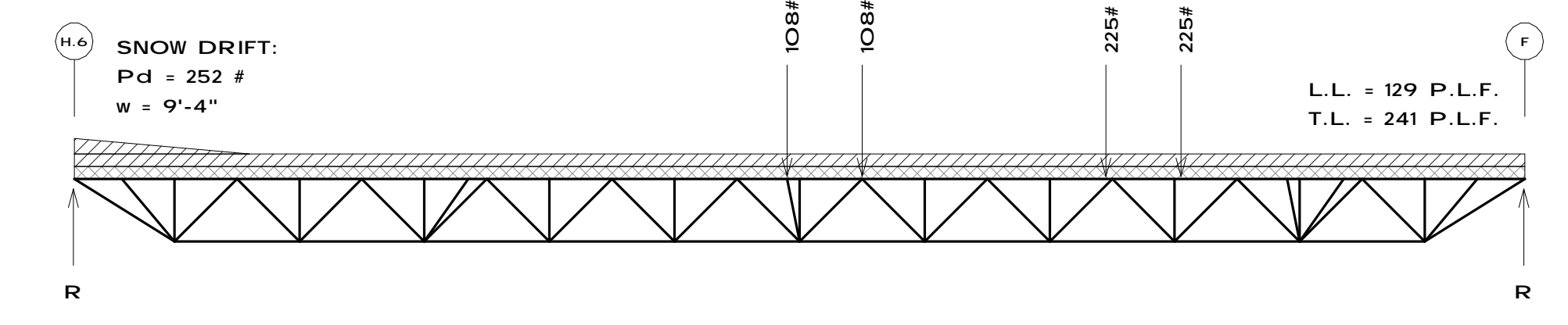

1 SP-J6
1/8" = 1'-0"

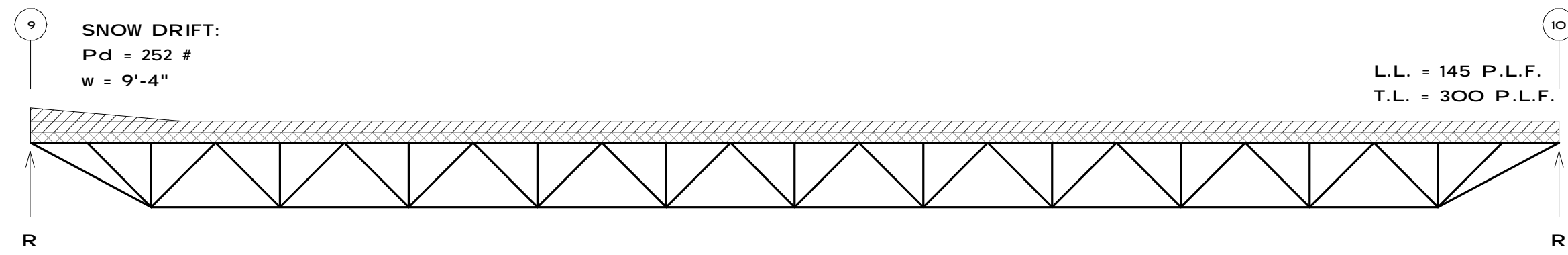

14 SP-J29
1/8" = 1'-0"

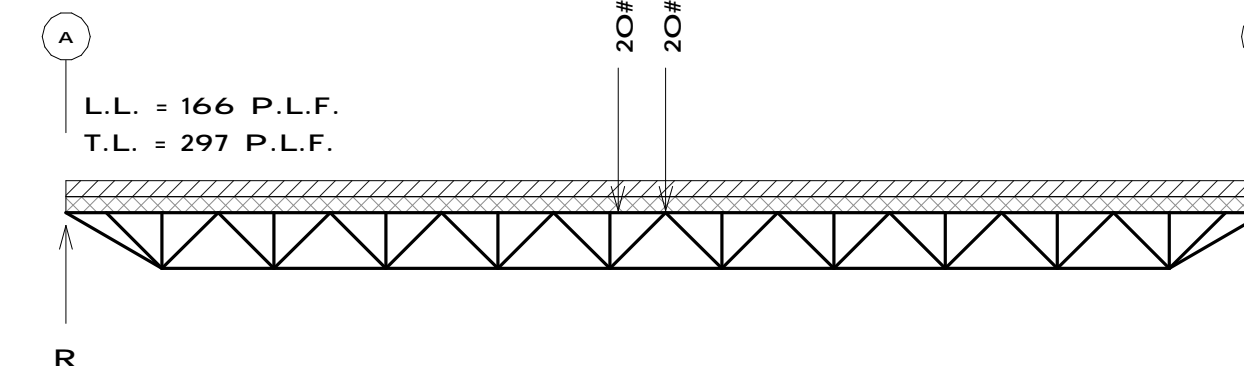

6 SP-J21
1/8" = 1'-0"

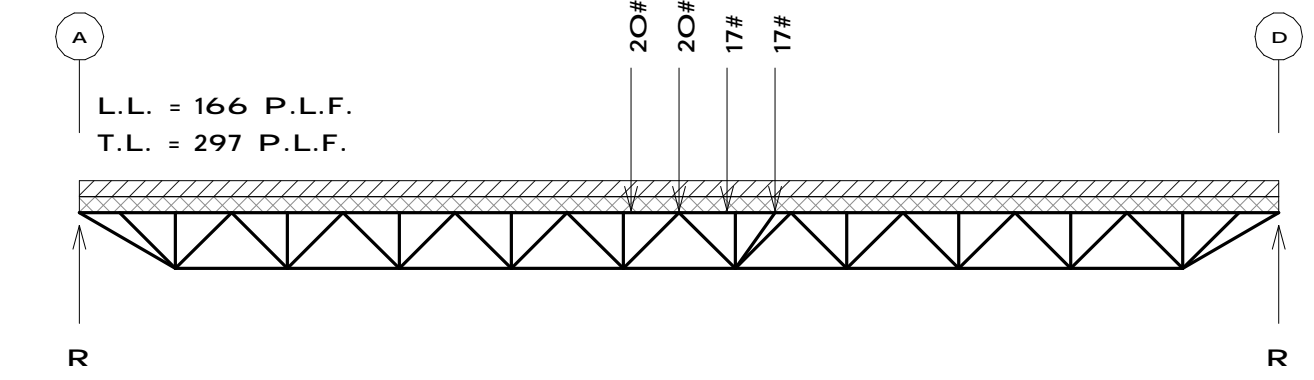

7 SP-J22
1/8" = 1'-0"

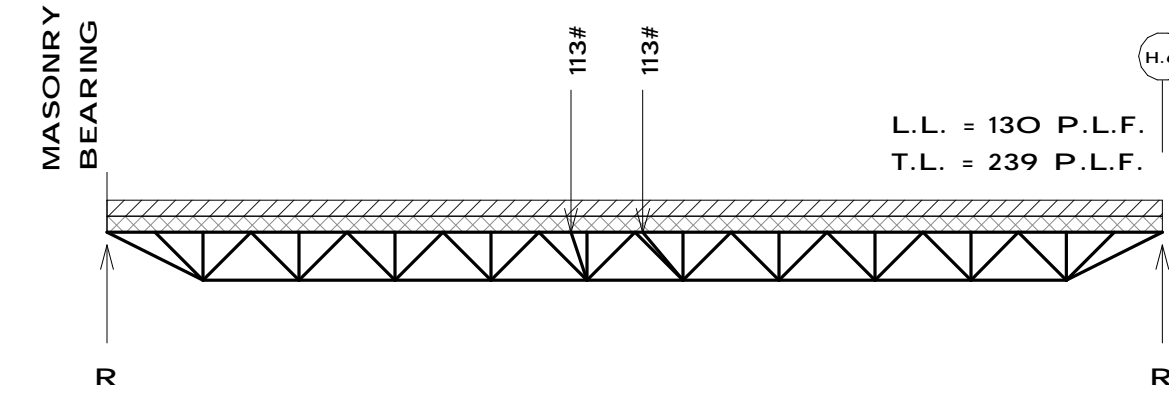

13 SP-J28
1/8" = 1'-0"

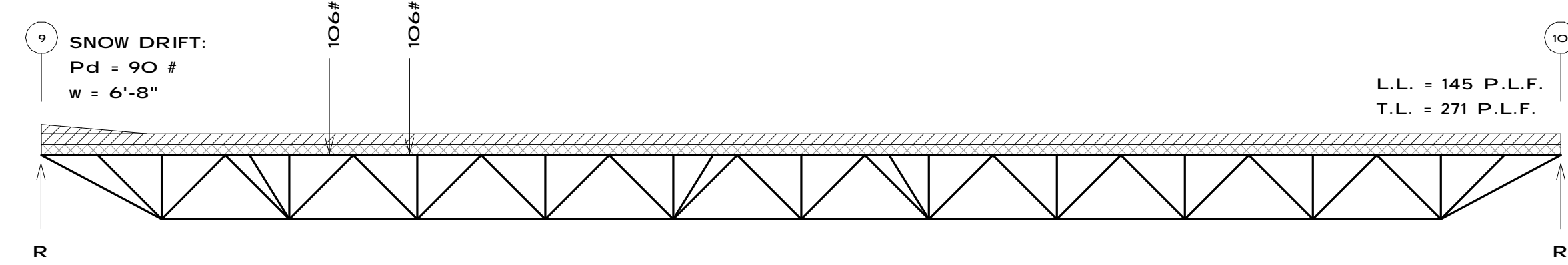

5 SP-J20
1/8" = 1'-0"

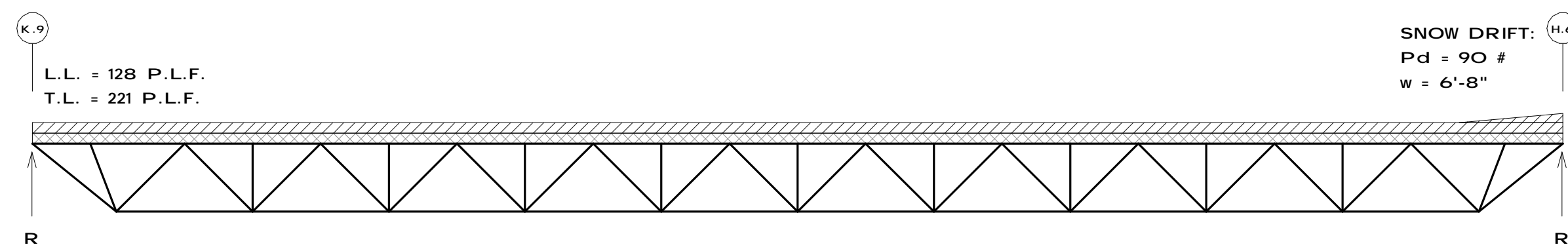

12 SP-J27
1/8" = 1'-0"

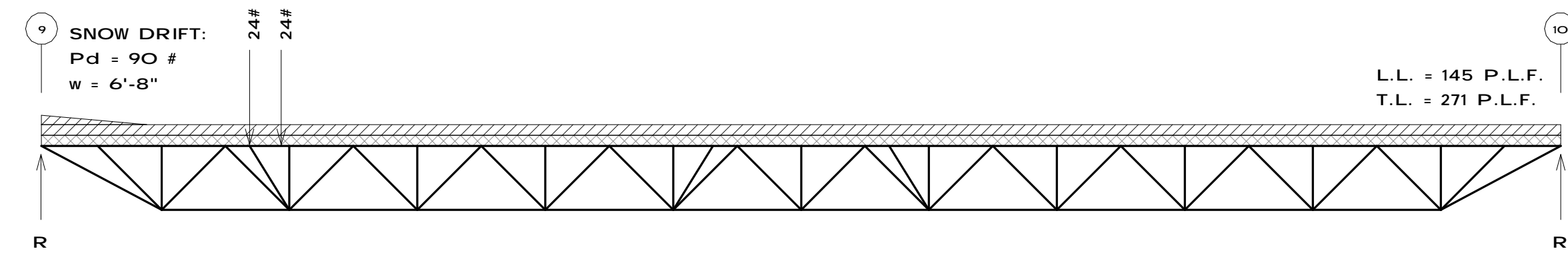

4 SP-J19
1/8" = 1'-0"

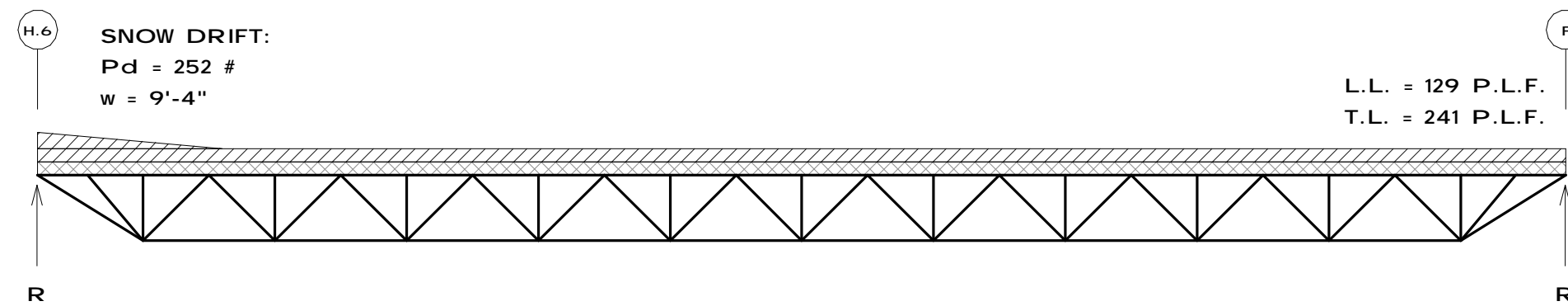

11 SP-J26
1/8" = 1'-0"

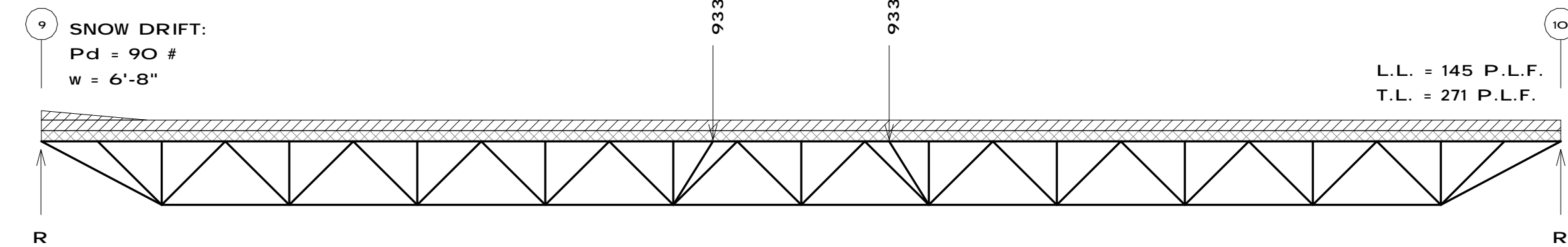

3 SP-J18
1/8" = 1'-0"

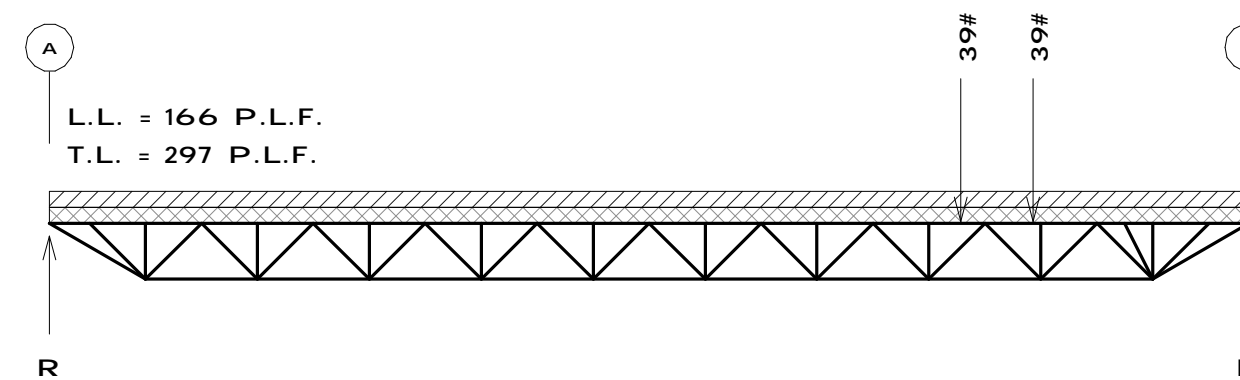

10 SP-J25
1/8" = 1'-0"

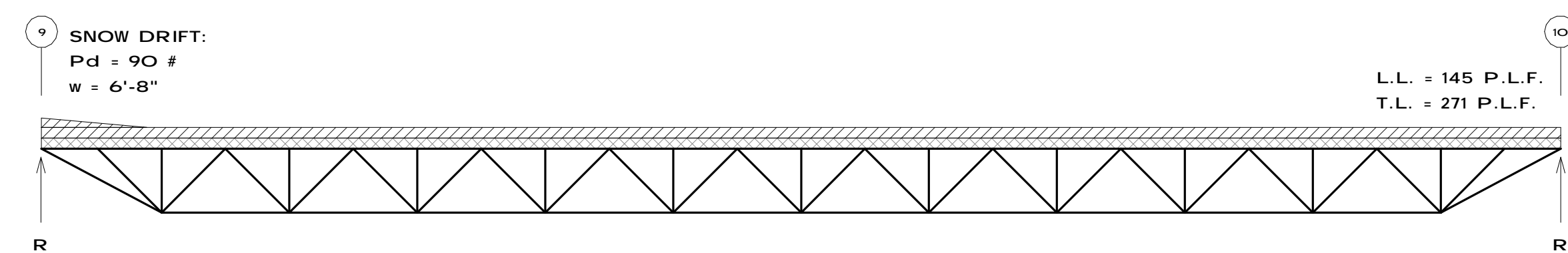

2 SP-J17
1/8" = 1'-0"

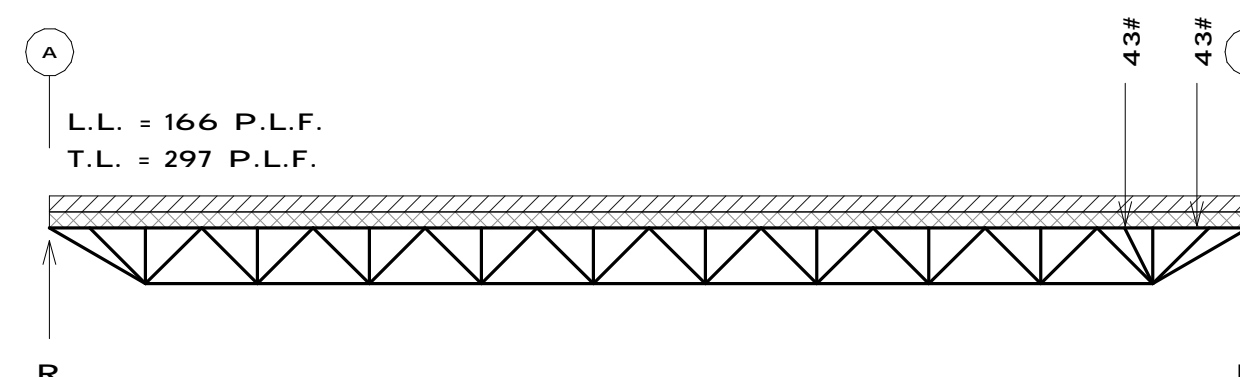

9 SP-J24
1/8" = 1'-0"

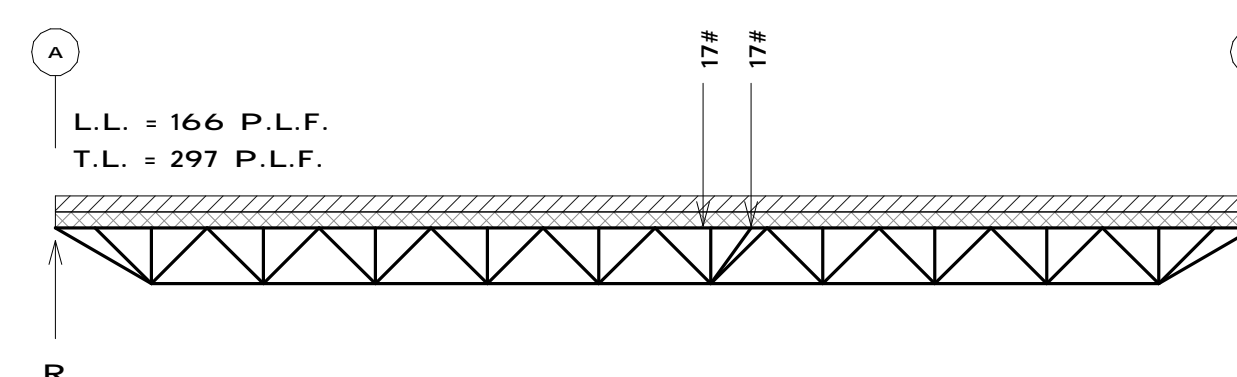

8 SP-J23
1/8" = 1'-0"

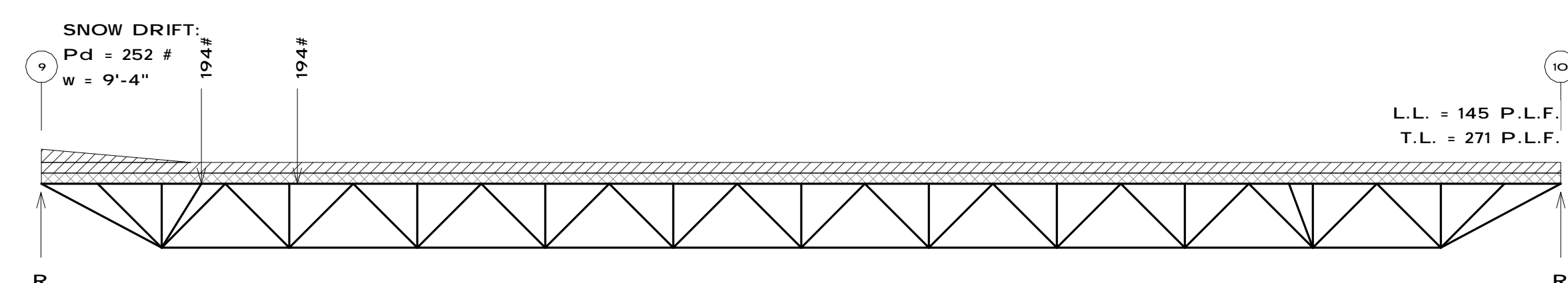

1 SP-J16A
1/8" = 1'-0"

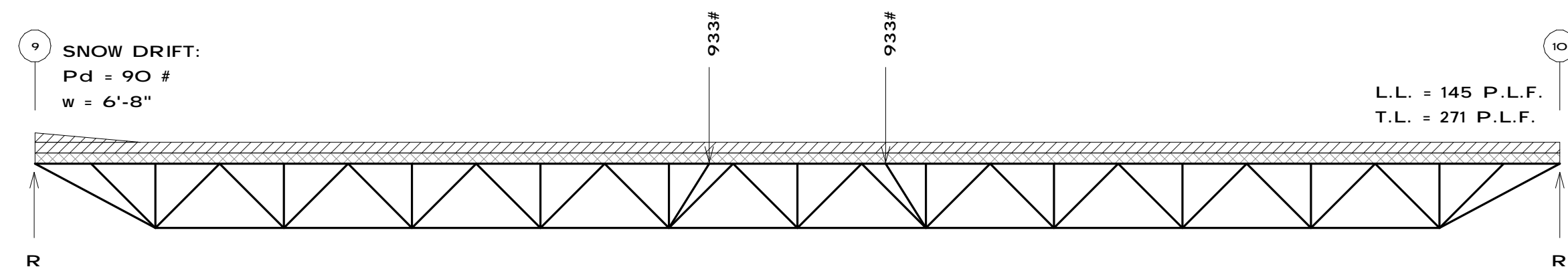

14 SP-J43
1/8" = 1'-0"

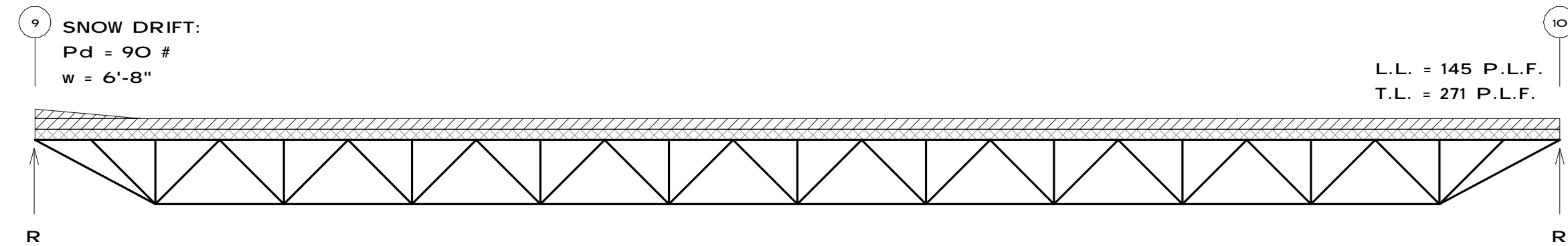

13 SP-J42
1/8" = 1'-0"

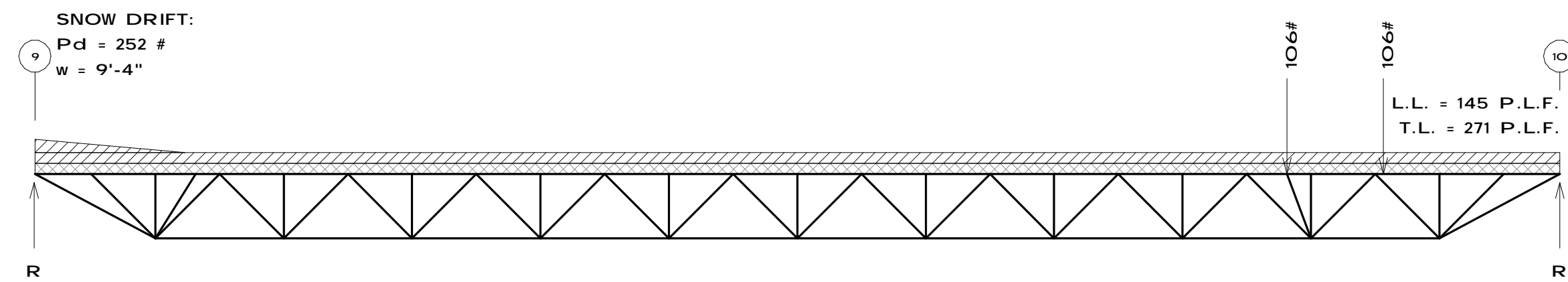

12 SP-J41
1/8" = 1'-0"

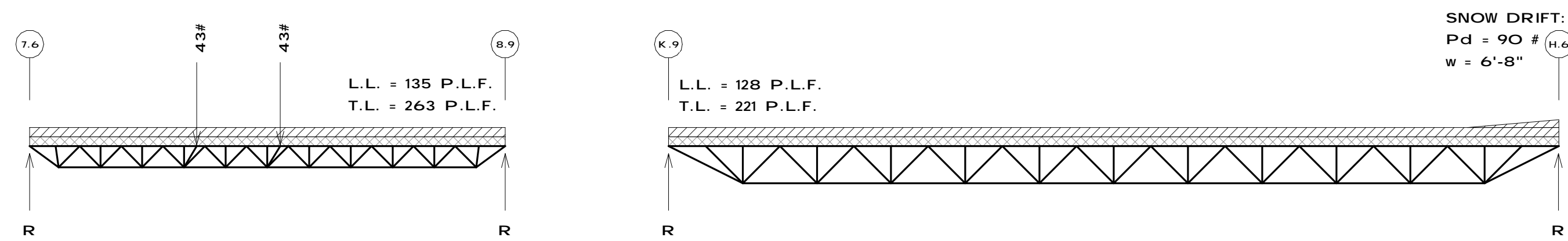

11 SP-J40
1/8" = 1'-0"

10 SP-J39
1/8" = 1'-0"

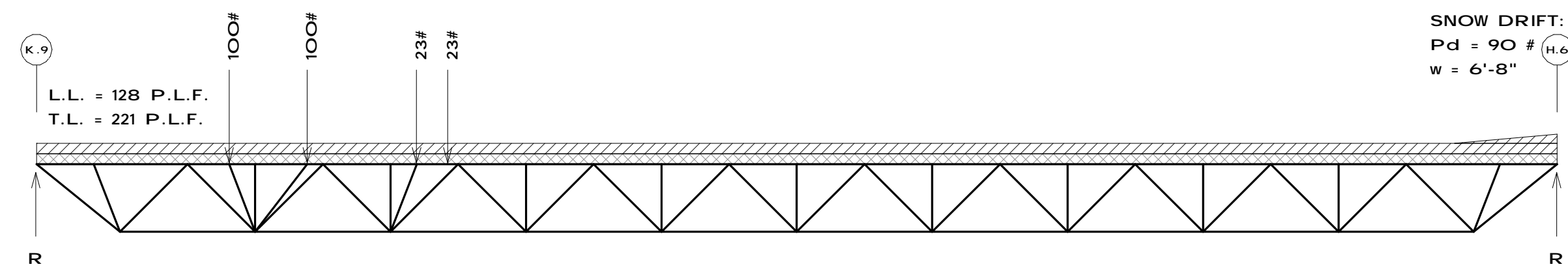

9 SP-J38
1/8" = 1'-0"

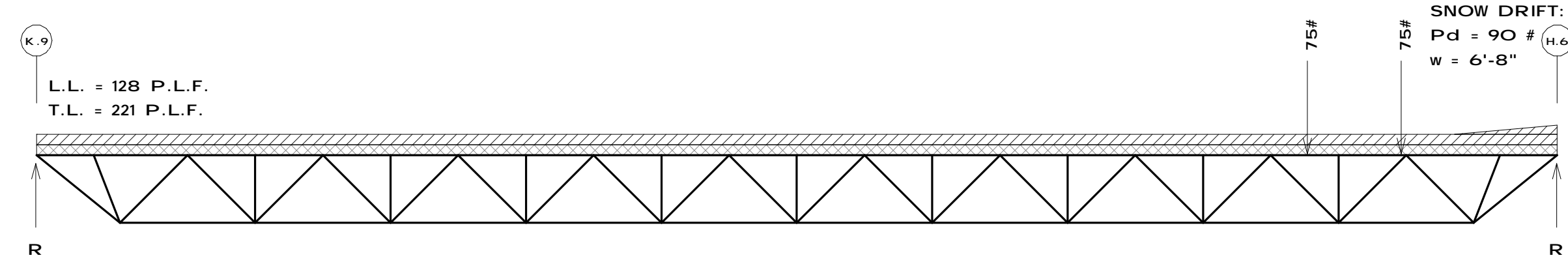

8 SP-J37
1/8" = 1'-0"

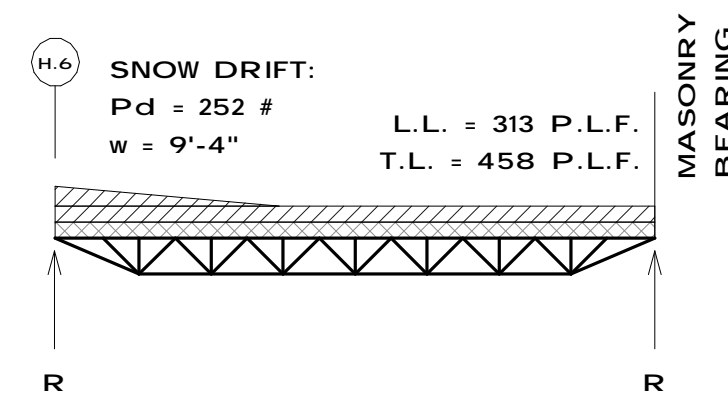

7 SP-J36
1/8" = 1'-0"

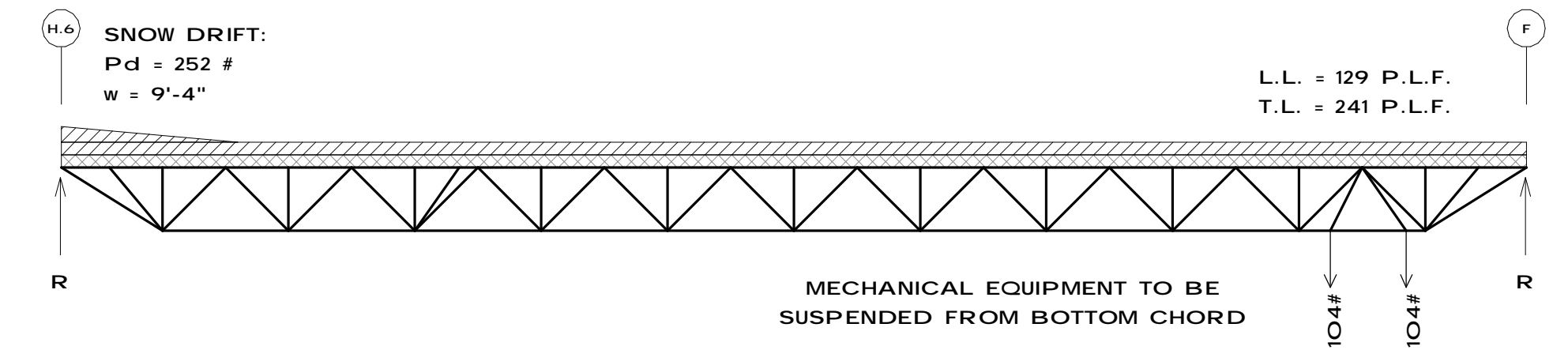

6 SP-J35
1/8" = 1'-0"

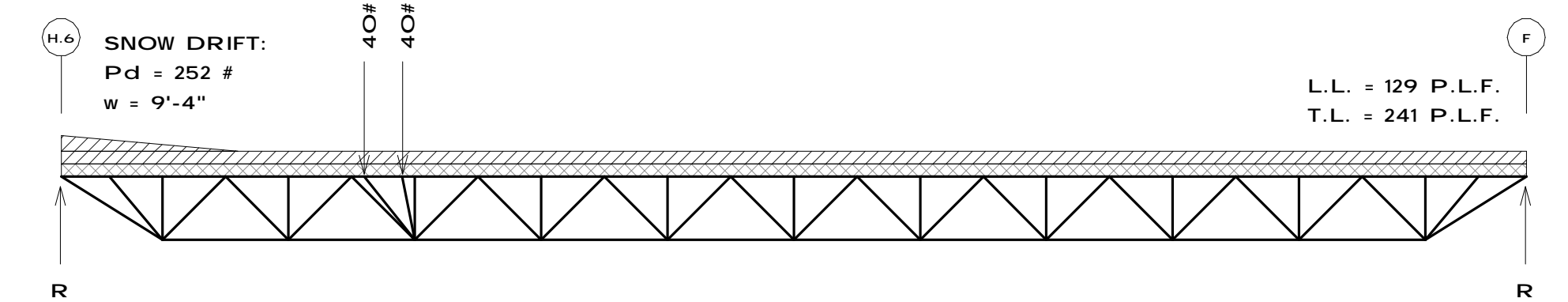

5 SP-J34
1/8" = 1'-0"

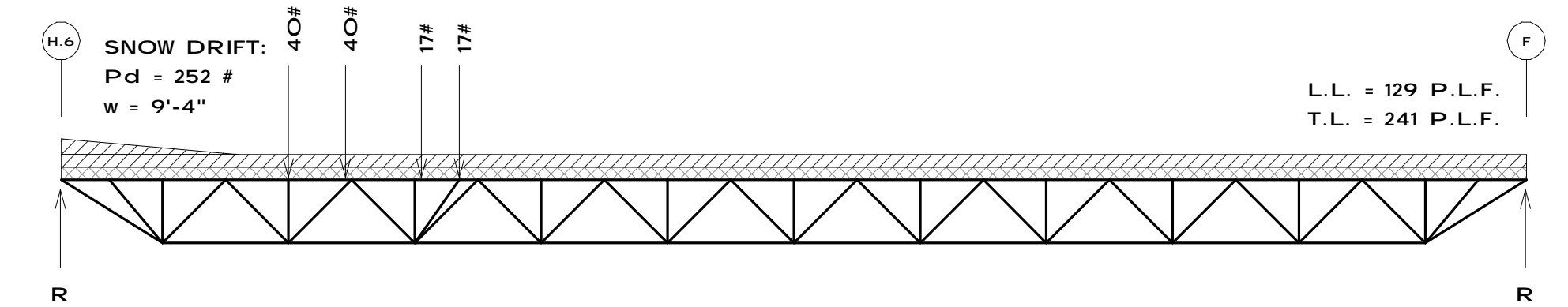

4 SP-J33
1/8" = 1'-0"

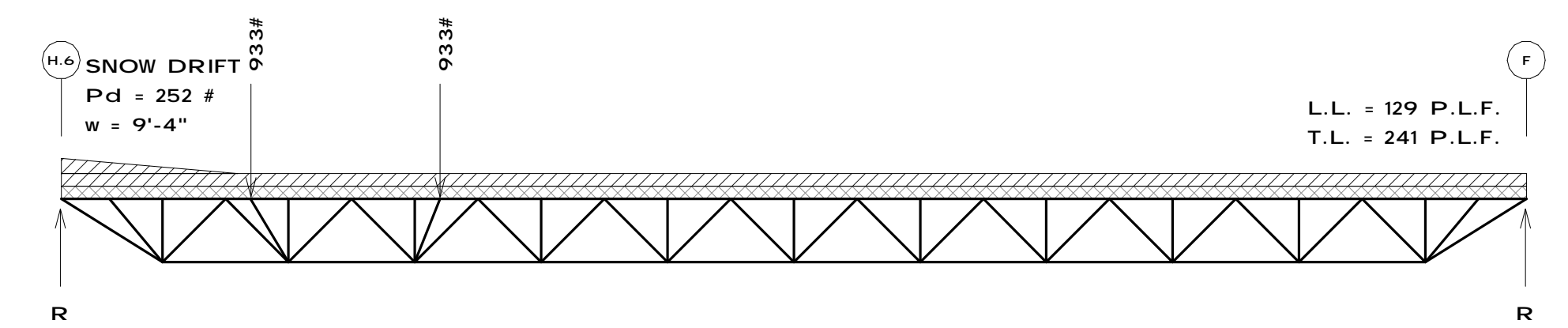

3 SP-J32
1/8" = 1'-0"

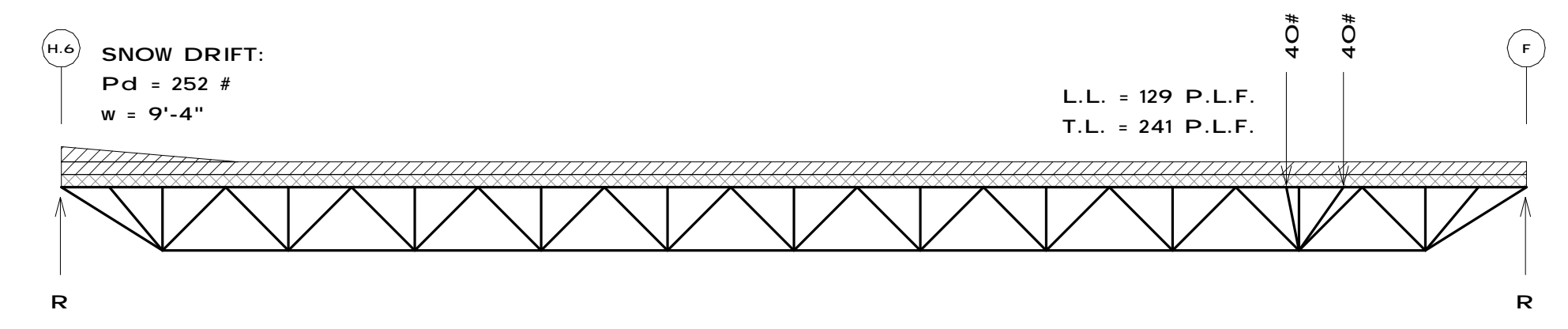

2 SP-J31
1/8" = 1'-0"

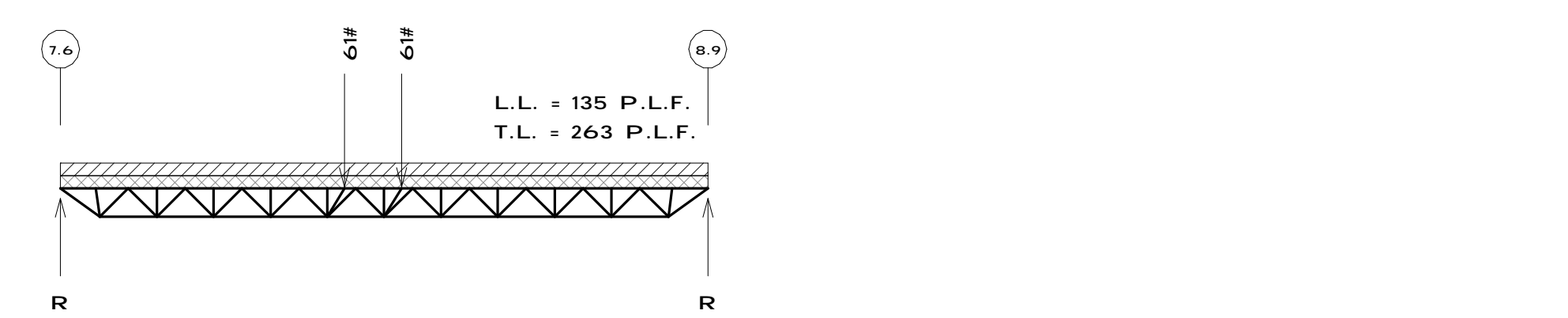

1 SP-J30
1/8" = 1'-0"

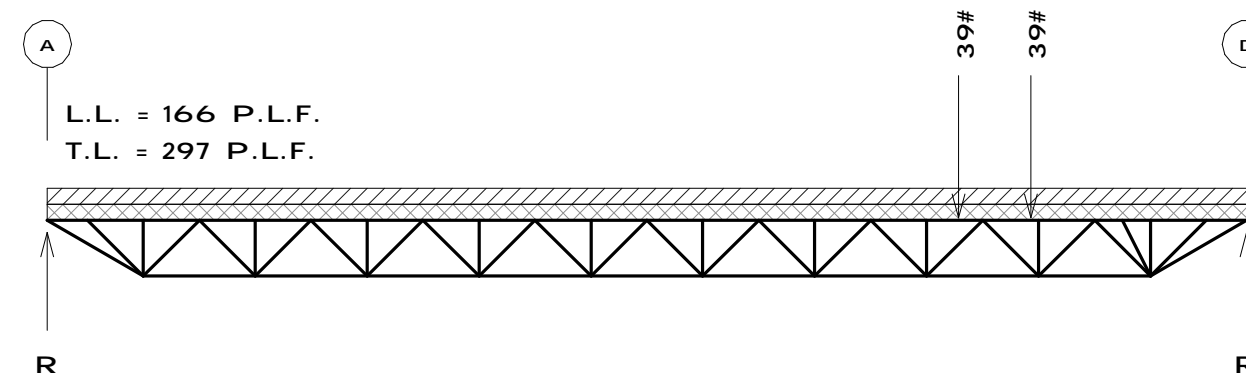

7 SP-J50
1/8" = 1'-0"

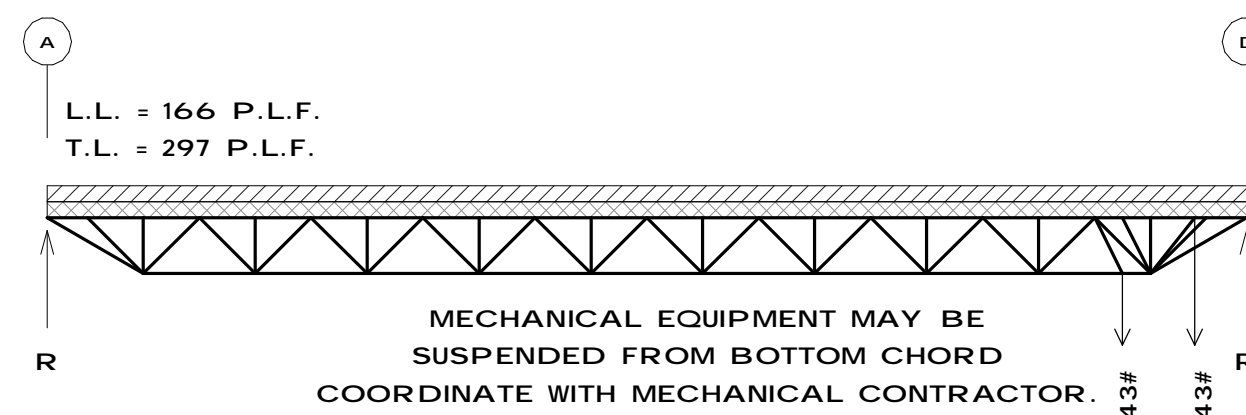

6 SP-J49
1/8" = 1'-0"

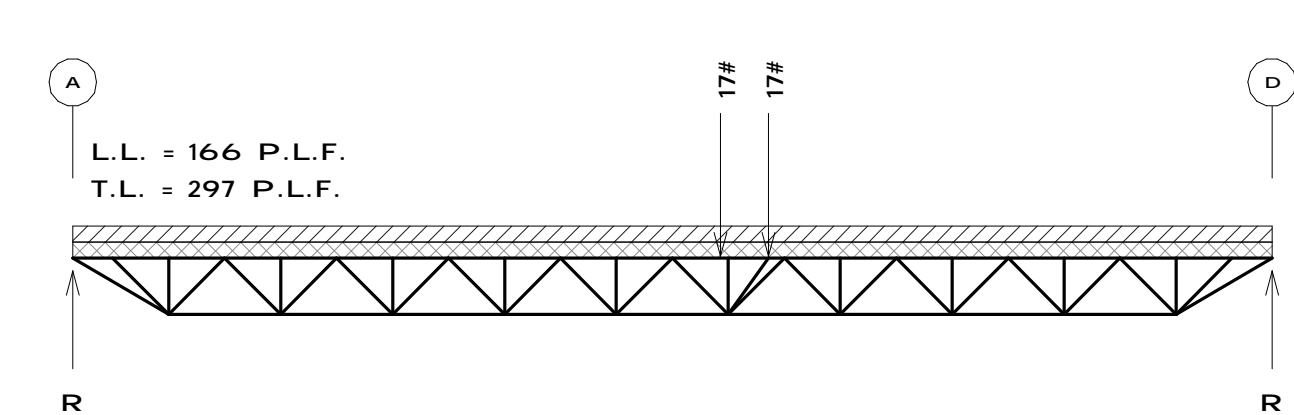

5 SP-J48
1/8" = 1'-0"

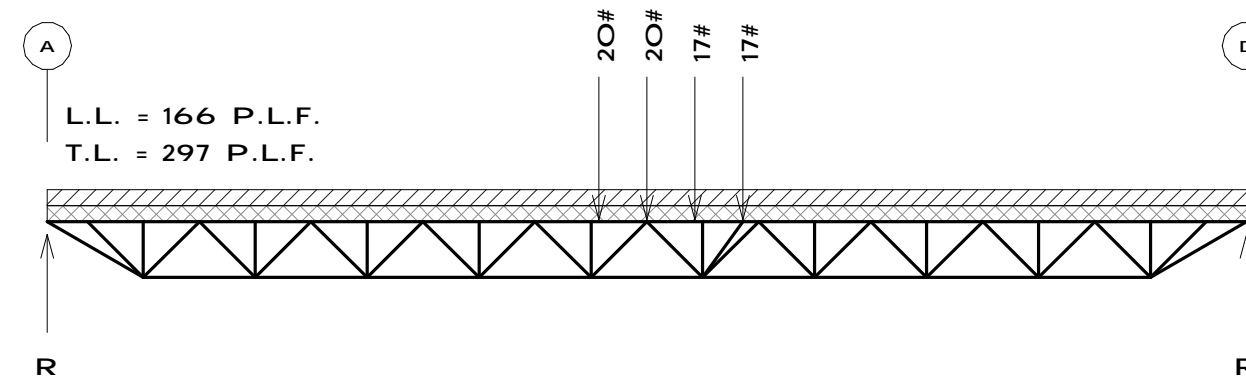

4 SP-J47
1/8" = 1'-0"

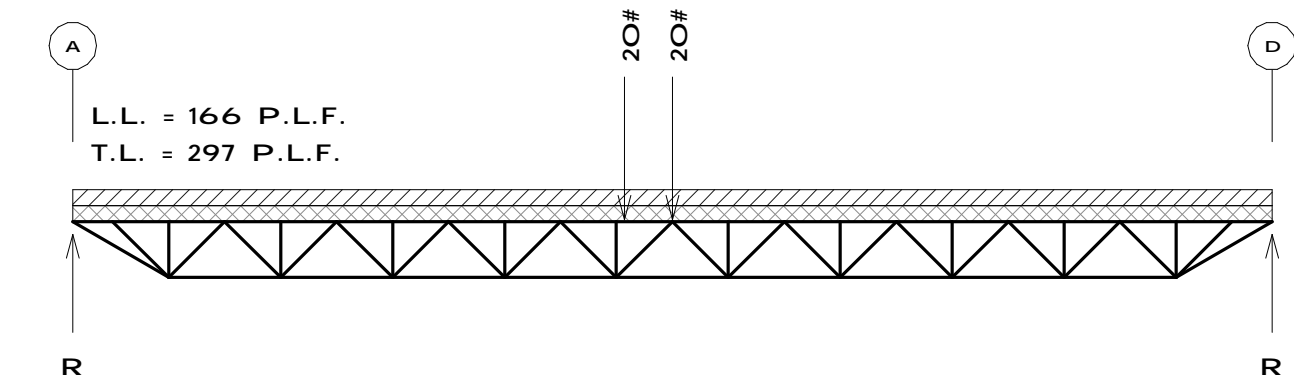

3 SP-J46
1/8" = 1'-0"

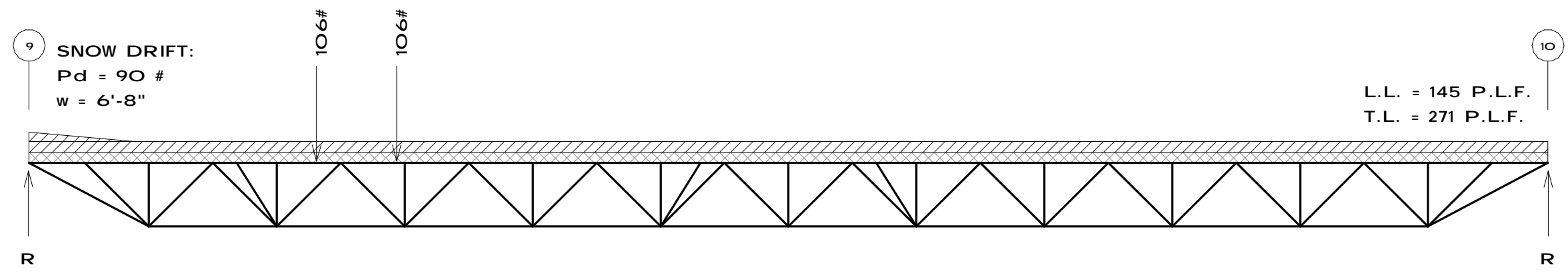

2 SP-J45
1/8" = 1'-0"

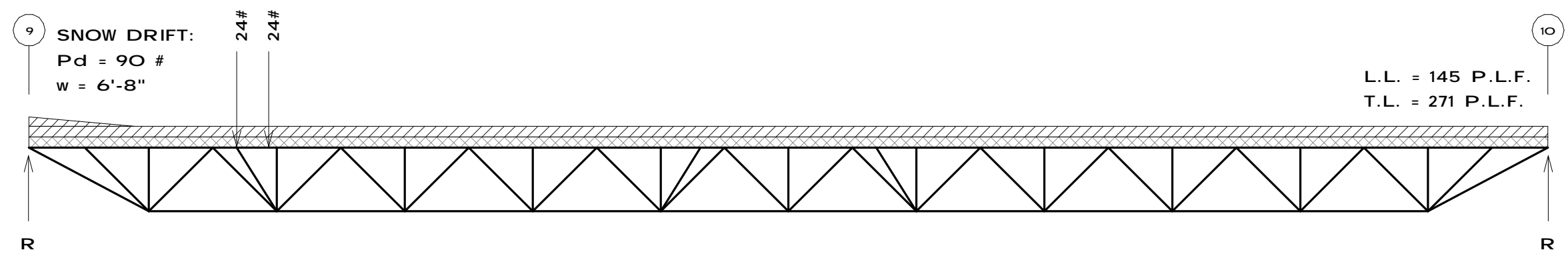

1 SP-J44
1/8" = 1'-0"

SEE SHEET A-904 FOR METAL DECK TYPES

- STRUCTURAL LOAD TAG

MARK	CONCENTRATED LOAD			UNIFORM LOAD		
	LL (k)	DL (k)	TL (k)	LL (plf)	DL (plf)	TL (plf)
30	0.0	0.0	0.0	42	30	72
31	3.2	2.7	5.9	0	0	0

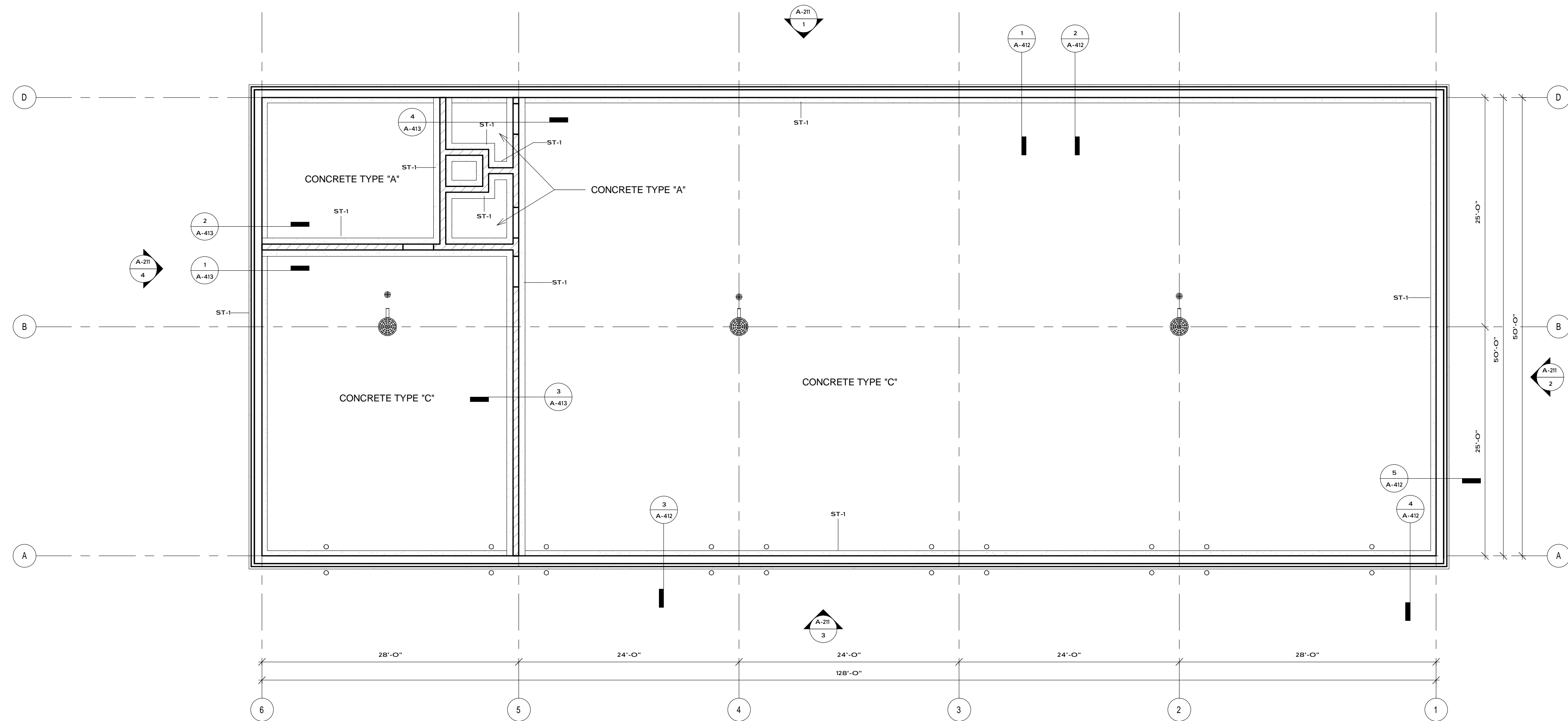
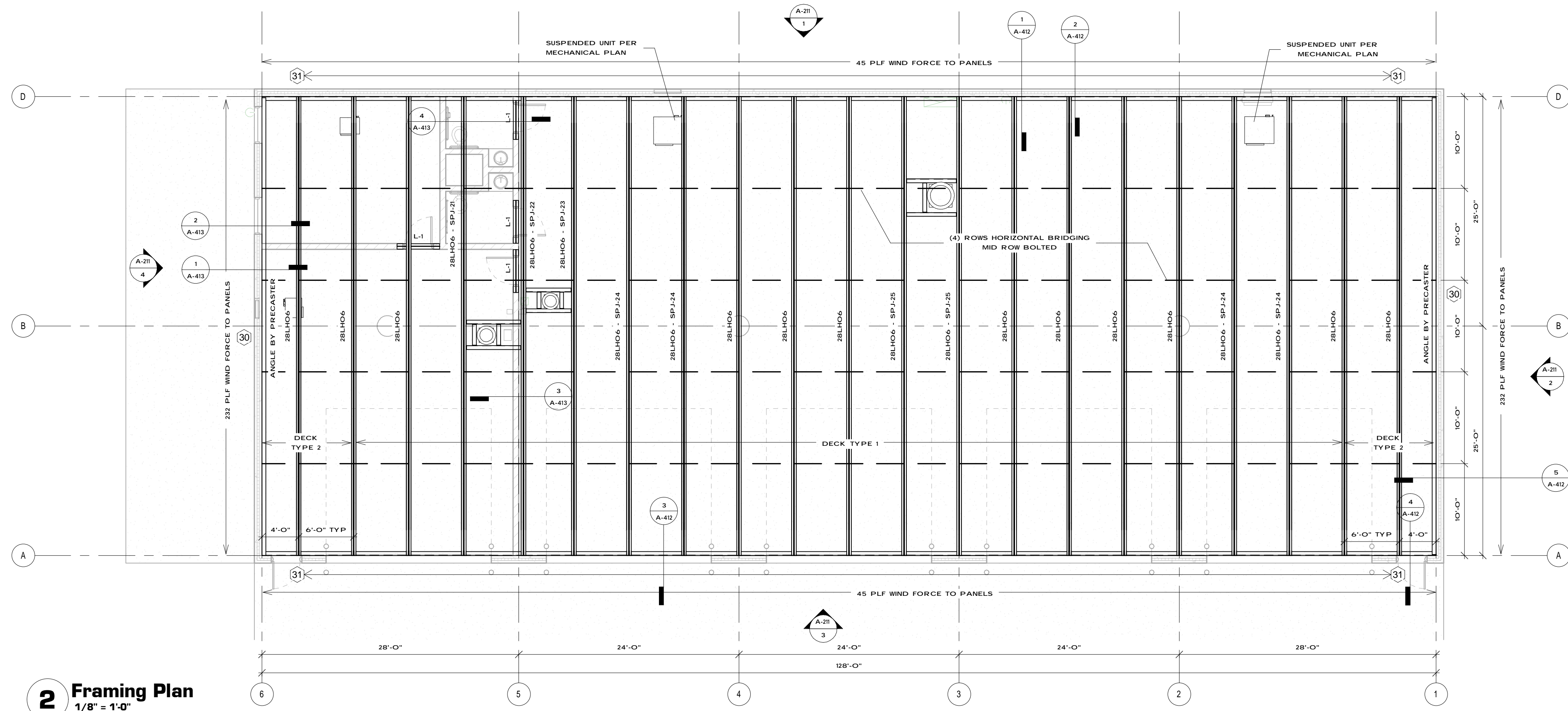

Satellite Building - Foundation and Framing Plan

kuenyarch.com ©2015 Kueny Architects L.L.C. - All Rights Reserved
Dane County - Highway Facility Satellite Building
US 151 and County Highway V
January 12, 2015

PLAN NORTH
SCALE: 1/8" = 1'-0"
S-910