

GENERAL REQUIREMENTS:

1.1 INTENT

1. THESE SPECIFICATIONS AND CONSTRUCTION DRAWINGS ACCOMPANYING THEM DESCRIBE THE WORK TO BE DONE AND THE MATERIALS TO BE FURNISHED FOR CONSTRUCTION.
2. THE DRAWINGS AND SPECIFICATIONS ARE INTENDED TO BE FULLY EXPLANATORY AND SUPPLEMENTARY. HOWEVER, SHOULD ANYTHING BE SHOWN, INDICATED OR SPECIFIED ON ONE AND NOT THE OTHER, IT SHALL BE DONE THE SAME AS IF SHOWN, INDICATED OR SPECIFIED IN BOTH.
3. THE INTENTION OF THE DOCUMENTS IS TO INCLUDE ALL LABOR AND MATERIALS REASONABLY NECESSARY FOR THE PROPER EXECUTION AND COMPLETION OF THE WORK AS STIPULATED IN THE CONTRACT.
4. THE PURPOSE OF THE SPECIFICATIONS IS TO INTERPRET THE INTENT OF THE DRAWINGS AND TO DESIGNATE THE METHOD OF THE PROCEDURE, TYPE AND QUALITY OF MATERIALS REQUIRED TO COMPLETE THE WORK.
5. MINOR DEVIATIONS FROM THE DESIGN LAYOUT ARE ANTICIPATED AND SHALL BE CONSIDERED AS PART OF THE WORK. NO CHANGES THAT ALTER THE CHARACTER OF THE WORK WILL BE MADE OR PERMITTED BY THE OWNER WITHOUT ISSUING A CHANGE ORDER.

1.2 CONFLICTS

1. THE CONTRACTOR SHALL BE RESPONSIBLE FOR VERIFICATION OF ALL MEASUREMENTS AT THE SITE BEFORE ORDERING ANY MATERIALS OR DOING ANY WORK. NO EXTRA CHARGE OR COMPENSATION SHALL BE ALLOWED DUE TO DIFFERENCE BETWEEN ACTUAL DIMENSIONS AND DIMENSIONS INDICATED ON THE CONSTRUCTION DRAWINGS. ANY SUCH DISCREPANCY IN DIMENSION WHICH MAY BE FOUND SHALL BE SUBMITTED TO THE OWNER FOR CONSIDERATION BEFORE THE CONTRACTOR PROCEEDS WITH THE WORK IN THE AFFECTED AREAS.
2. THE BIDDER, IF AWARDED THE CONTRACT, WILL NOT BE ALLOWED ANY EXTRA COMPENSATION BY REASON OF ANY MATTER OR THING CONCERNING WHICH SUCH BIDDER MIGHT HAVE FULLY INFORMED THEMSELVES PRIOR TO THE BIDDING.
3. NO PLEA OF IGNORANCE OF CONDITIONS THAT EXIST, OR OF DIFFICULTIES OR CONDITIONS THAT MAY BE ENCOUNTERED OR OF ANY OTHER RELEVANT MATTER CONCERNING THE WORK TO BE PERFORMED IN THE EXECUTION OF THE WORK WILL BE ACCEPTED AS AN EXCUSE FOR ANY FAILURE OR OMISSION ON THE PART OF THE CONTRACTOR TO FULFILL EVERY DETAIL OF ALL THE REQUIREMENTS OF THE CONTRACT DOCUMENTS GOVERNING THE WORK.

1.3 CONTRACTS AND WARRANTIES

1. CONTRACTOR IS RESPONSIBLE FOR APPLICATION AND PAYMENT OF CONTRACTOR LICENSES AND BONDS.

1.4 STORAGE

1. ALL MATERIALS MUST BE STORED IN A LEVEL AND DRY FASHION AND IN A MANNER THAT DOES NOT NECESSARILY OBSTRUCT THE FLOW OF OTHER WORK. ANY STORAGE METHOD MUST MEET ALL RECOMMENDATIONS OF THE ASSOCIATED MANUFACTURER.

1.5 CLEAN UP

1. THE CONTRACTORS SHALL AT ALL TIMES KEEP THE SITE FREE FROM ACCUMULATION OF WASTE MATERIALS OR RUBBISH CAUSED BY THEIR EMPLOYEES AT WORK AND AT THE COMPLETION OF THE WORK, THEY SHALL REMOVE ALL RUBBISH FROM AND ABOUT THE BUILDING AREA, INCLUDING ALL THEIR TOOLS, SCAFFOLDING AND SURPLUS MATERIALS AND SHALL LEAVE THEIR WORK CLEAN AND READY FOR USE.
2. EXTERIOR: VISUALLY INSPECT EXTERIOR SURFACES AND REMOVE ALL TRACES OF SOIL, WASTE MATERIALS, SMUDGES AND OTHER FOREIGN MATTER.
 - A. REMOVE ALL TRACES OF SPLASHED MATERIALS FROM ADJACENT SURFACES.
 - B. IF NECESSARY TO ACHIEVE A UNIFORM DEGREE OF CLEANLINESS, HOSE DOWN THE EXTERIOR OF THE STRUCTURE.
3. INTERIOR: VISUALLY INSPECT INTERIOR SURFACE AND REMOVE ALL TRACES OF SOIL, WASTE MATERIALS, SMUDGES AND OTHER FOREIGN MATTER FROM WALLS/FLOOR/CEILING.
 - A. REMOVE ALL TRACES OF SPLASHED MATERIAL FROM ADJACENT SURFACES.
 - B. REMOVE PAINT DROPPINGS, SPOTS, STAINS AND DIRT FROM FINISHED SURFACES.

GENERAL REQUIREMENTS (CONT.):

1.6 CHANGE ORDER PROCEDURE

1. CHANGE ORDERS MAY BE INITIATED BY THE OWNER AND/OR THE CONTRACTOR INVOLVED. THE CONTRACTOR, UPON VERBAL REQUEST FROM THE OWNER SHALL PREPARE A WRITTEN PROPOSAL DESCRIBING THE CHANGE IN WORK OR MATERIALS AND ANY CHANGES IN THE CONTRACT AMOUNT AND PRESENT TO THE OWNER & ENGINEER WITHIN 72 HRS FOR APPROVAL. SUBMIT REQUESTS FOR SUBSTITUTIONS IN THE FORM AND IN ACCORDANCE WITH PROCEDURES REQUIRED FOR CHANGE ORDER PROPOSALS. ANY CHANGES IN SCOPE OF WORK OR MATERIALS WHICH ARE PERFORMED BY THE CONTRACTOR WITHOUT A WRITTEN CHANGE ORDER AS DESCRIBED AND APPROVED BY THE ENGINEER AND OWNER SHALL PLACE FULL RESPONSIBILITY OF THESE ACTIONS ON THE CONTRACTOR.

1.7 RELATED DOCUMENTS AND COORDINATION

1. GENERAL CARPENTRY, ELECTRICAL AND ANTENNA DRAWINGS ARE INTERRELATED. IN PERFORMANCE OF THE WORK, THE CONTRACTOR MUST REFER TO ALL DRAWINGS. ALL COORDINATION TO BE THE RESPONSIBILITY OF THE CONTRACTOR.

1.8 SHOP DRAWINGS

1. CONTRACTOR SHALL SUBMIT SHOP DRAWINGS AS REQUIRED AND LISTED IN THESE SPECIFICATIONS TO THE ENGINEER AND OWNER FOR APPROVAL.
2. ALL SHOP DRAWINGS SHALL BE REVIEWED, CHECKED AND CORRECTED BY CONTRACTOR PRIOR TO SUBMITTAL TO THE OWNER.

1.9 PRODUCTS AND SUBSTITUTIONS

1. SUBMIT (3) HARD COPIES OR (1) SOFT COPY PER EACH REQUEST FOR SUBSTITUTION. IN EACH REQUEST IDENTIFY THE PRODUCT OR FABRICATION OR INSTALLATION METHOD TO BE REPLACED BY THE SUBSTITUTION. INCLUDE RELATED SPECIFICATION SECTION AND DRAWING NUMBERS AND COMPLETE DOCUMENTATION SHOWING COMPLIANCE WITH THE REQUIREMENTS FOR SUBSTITUTIONS.
2. SUBMIT ALL NECESSARY PRODUCT DATA AND CUT SHEETS WHICH PROPERLY INDICATE AND DESCRIBE THE ITEMS, PRODUCTS AND MATERIALS BEING INSTALLED. THE CONTRACTOR SHALL, IF DEEMED NECESSARY BY THE ENGINEER AND OWNER SUBMIT ACTUAL SAMPLES TO THE ENGINEER & OWNER FOR APPROVAL IN LIEU OF CUT SHEETS.

1.10 QUALITY ASSURANCE

1. ALL WORK SHALL BE IN ACCORDANCE WITH APPLICABLE LOCAL, STATE AND FEDERAL REGULATIONS. THESE SHALL INCLUDE BUT NOT BE LIMITED TO THE LATEST VERSION OF THE LOCAL BUILDING CODE.

1.11 ADMINISTRATION

1. BEFORE THE COMMENCEMENT OF ANY WORK, THE CONTRACTOR WILL ASSIGN A PROJECT MANAGER WHO WILL ACT AS A SINGLE POINT OF CONTACT FOR ALL PERSONNEL INVOLVED IN THIS PROJECT. THIS PROJECT MANAGER WILL DEVELOP A MASTER SCHEDULE FOR THE PROJECT WHICH WILL BE SUBMITTED TO THE OWNER PRIOR TO THE COMMENCEMENT OF ANY WORK.
2. SUBMIT A BAR TYPE PROGRESS CHART NOT MORE THAN 3 DAYS AFTER THE DATE ESTABLISHED FOR COMMENCEMENT OF THE WORK ON THE SCHEDULE, INDICATING A TIME BAR FOR EACH MAJOR CATEGORY OR UNIT OF WORK TO BE PERFORMED AT SITE, PROPERLY SEQUENCED AND COORDINATED WITH OTHER ELEMENTS OF WORK AND SHOWING COMPLETION OF THE WORK SUFFICIENTLY IN ADVANCE OF THE DATE ESTABLISHED FOR SUBSTANTIAL COMPLETION OF THE WORK.
3. PRIOR TO COMMENCING CONSTRUCTION, THE OWNER SHALL SCHEDULE AN ON-SITE MEETING WITH ALL MAJOR PARTIES. THIS WOULD INCLUDE (THOUGH NOT LIMITED TO) THE OWNER, PROJECT MANAGER/ENGINEER, CONTRACTOR, AND TOWER ERECTION FOREMAN (IF SUBCONTRACTED).
4. CONTRACTOR SHALL BE EQUIPPED WITH SOME MEANS OF CONSTANT COMMUNICATIONS, SUCH AS A MOBILE PHONE OR A BEEPER. THIS EQUIPMENT WILL NOT BE SUPPLIED BY THE OWNER, NOR WILL WIRELESS SERVICE BE ARRANGED.
5. DURING CONSTRUCTION, CONTRACTOR MUST ENSURE THAT EMPLOYEES AND SUBCONTRACTORS WEAR HARD HATS AT ALL TIMES. CONTRACTOR WILL COMPLY WITH ALL SAFETY REQUIREMENTS IN THEIR AGREEMENT.
6. PROVIDE WRITTEN WEEKLY UPDATES ON SITE PROGRESS TO THE OWNER.
7. COMPLETE INVENTORY OF CONSTRUCTION MATERIALS AND EQUIPMENT IS REQUIRED PRIOR TO START OF CONSTRUCTION.
8. NOTIFY THE OWNER / PROJECT MANAGER IN WRITING NO LESS THAN 48 HOURS IN ADVANCE OF CONCRETE POURS, TOWER ERECTIONS, AND EQUIPMENT CABINET PLACEMENTS.

1.12 INSURANCE AND BONDS - REFER TO SPECIFICATIONS

TOWER & ANTENNA INSTALLATION:

1.1 WORK INCLUDED

1. IF REQUIRED, ERECT FURNISHED TOWER.
2. GROUND TOWER TEMPORARILY DURING ERECTION. GROUNDING SHALL INCLUDE BASE(S) AND ANCHORS.
3. IF REQUIRED, INSTALL THREE (3) SIDE ARMS, CONSISTING OF THREE (3) 6'-0" AS INDICATED ON DRAWINGS - CONFIRM WITH ENGINEER OR OWNER.
4. INSTALL ANTENNAS AS INDICATED ON DRAWINGS AND OWNER SPECIFICATIONS.
5. INSTALL GALVANIZED STEEL ANTENNA MOUNTS AS INDICATED ON DRAWINGS.
6. INSTALL WAVEGUIDE BRIDGE AS INDICATED ON DRAWINGS.
7. SUPPLY AND INSTALL ONE INSULATED GROUND BAR AT EQUIPMENT CABINET.
8. SUPPLY AND INSTALL GROUNDING STRAP KITS WITH LONG BARREL COMPRESSION LUGS (SIM. TO ANDREW-223700TBD OR APPROVED EQUAL) ATOP TOWER BASE BEFORE ENTERING THE EQUIPMENT. GROUNDING STRAPS TO BE CONNECTED TO INSULATED GROUND BAR.
9. ASSIST OWNER TECHNICIANS IN PERFORMING SWEEP TEST OF INSTALLED CABLES.
10. CONCRETE PIERS FOR FOUNDATIONS SHALL BE DRILLED AND POURED ON THE SAME DAY.

1.2 REQUIREMENTS OF REGULATOR AGENCIES

1. FURNISH U.L. LISTED EQUIPMENT WHERE SUCH LABEL IS AVAILABLE, INSTALL IN CONFORMANCE WITH U.L. STANDARDS WHERE APPLICABLE.
2. INSTALL ANTENNA, ANTENNA CABLES, GROUNDING SYSTEM IN ACCORDANCE WITH DRAWINGS AND SPECIFICATION IN EFFECT AT PROJECT LOCATION AND RECOMMENDATIONS OF STATE AND LOCAL BUILDING CODES, SPECIAL CODES HAVING JURISDICTION OVER SPECIFIC PORTIONS OF WORK. THIS INCLUDES BUT IS NOT LIMITED TO THE FOLLOWING:
 - A. TIA - TELECOMMUNICATIONS INDUSTRY ASSOCIATION TIA-222-G. STRUCTURAL STANDARDS FOR STEEL ANTENNA TOWERS AND ANTENNA SUPPORTING STRUCTURES.
 - B. FAA - FEDERAL AVIATION ADMINISTRATION ADVISORY CIRCULAR AC 70/7460-IH, OBSTRUCTION MARKING AND LIGHTING.
 - C. FCC - FEDERAL COMMUNICATIONS COMMISSION RULES AND REGULATIONS FORM 715, OBSTRUCTION MARKING AND LIGHTING SPECIFICATIONS FOR ANTENNA STRUCTURES AND FORM 715A, HIGH INTENSITY OBSTRUCTION LIGHTING SPECIFICATIONS FOR ANTENNA STRUCTURES.
 - D. AISC - AMERICAN INSTITUTE OF STEEL CONSTRUCTION SPECIFICATION FOR STRUCTURAL JOINTS USING ASTM A325 OR A490 BOLTS.
 - E. NEC - NATIONAL ELECTRICAL CODE - ON TOWER LIGHTING KITS.
 - F. UL - UNDERWRITER'S LABORATORIES APPROVED ELECTRICAL PRODUCTS.
 - G. IN ALL CASES, PART 77 OR THE FAA RULES AND PARTS 17 AND 22 OF THE FCC RULES ARE APPLICABLE AND IN THE EVENT OF CONFLICT, SUPERSEDE ANY OTHER STANDARDS OR SPECIFICATIONS.
 - H. LIFE SAFETY CODE NFPA -101.

DANE COUNTY DEPARTMENT OF PUBLIC WORKS & TRANSPORTATION
PUBLIC WORKS ENGINEERING DIVISION
1919 ALANT ENERGY CENTER WAY
MADISON, WI 53713



PROJECT NO. 321017

DANE COUNTY EMERGENCY MANAGEMENT BUILDING
5415 KING JAMES WAY
FITCHBURG, WI 53719



JEFF GUTOWSKY, P.E.; S.E.
WI LICENSE NO. 35509-6
EXPIRES: 07/31/22 SIGNED: 10/26/21

REVISIONS

REV.	ISSUED FOR	DATE	BY
1	FOR BIDDING	10/26/21	JTB

AQUATIC \ DESIGN & PROGRAM MANAGEMENT
CIVIL \ TELECOMMUNICATION \ MECHANICAL
PLUMBING \ ELECTRICAL \ LAND SURVEYING
ACCESSIBILITY CONSULTING \ STRUCTURAL

WT GROUP
Engineering with Precision, Pace and Passion.
2876 Pratum Avenue Hoffman Estates, IL 60192
T: 815.383.6333 F: 224.293.6444
wtgroupinc.com

WT Group
Engineering • Design • Consulting

CHECK: JKR
DRAWN: JTB
JOB: 20024707

N-1
GENERAL NOTES

GROUNDING STANDARDS:

1.0 DEFINITIONS

AGB: ANTENNA GROUND BAR
AWG: AMERICAN WIRE GAUGE
CADWELDING: AN EXOTHERMIC WELDING PROCESS WHICH CREATES POSITIVE CONTACT OF GROUNDING CONDUCTORS ELECTRICAL METAL TUBING (LIGHT GAUGE METALLIC CONDUIT)
EMT: MASTER GROUND BAR
MGB: POLYVINYL CHLORIDE CONDUIT
PVC: RADIO FREQUENCY INTERFERENCE
RFI: TOWER GROUND BAR
TGB: LETTER TYPE DESIGNATION FOR CONDUCTOR INSULATION THAT IS MOISTURE AND HEAT RESISTANT THERMOPLASTIC WITH A MAXIMUM OPERATING TEMPERATURE OF 75 DEGREES CELSIUS OR 167 DEGREES FAHRENHEIT
THWN: TENANT IMPROVEMENT

2.0 BACKGROUND

2.1 AREAS OF CONCERN

WHEN DESIGNING A GROUNDING SYSTEM FOR A MOBILE RADIO FACILITY THERE ARE FOUR INTERRELATED AREAS OF CONCERN. THE BASIC OBJECTIVE FOR EACH IS:

- 1. LIGHTNING PROTECTION -TO MAINTAIN ALL EQUIPMENT AT THE SAME POTENTIAL DURING A LIGHTNING IMPULSE.
2. RFI FOR NOISE INDUCTION CONTROL -TO ESTABLISH THE LOWEST POSSIBLE IMPEDANCE AMONG ALL EQUIPMENT.
3. ELECTROSTATIC CONTROL -TO REDUCE ELECTROSTATIC DISCHARGE PROBLEMS.
4. PERSONNEL SAFETY -TO MAINTAIN A MINIMUM VOLTAGE DIFFERENCE BETWEEN ANY TWO METALLIC OBJECTS WHICH PERSONNEL MIGHT CONTACT SIMULTANEOUSLY.

2.2 ALTERNATING CURRENT GROUNDING

IN THIS GROUNDING SYSTEM THE ALTERNATING CURRENT SERVICE GROUND SHALL BE KEPT ISOLATED FROM THE EQUIPMENT FRAME WORK AND LIGHTNING PROTECTION GROUND SYSTEMS EXCEPT FOR ONE SPECIFIC POINT. THIS POINT IS THE MAIN GROUNDING POINT OF THE SYSTEM. THIS WOULD TYPICALLY BE CONNECTING THE A/C SERVICE GROUND AT THE COMMERCIAL POWER RISER POLE DISCONNECT/METER BASE TO THE EXTERNAL GROUND RING. ALL GROUNDING CONNECTIONS INSIDE OF CABINETS SHALL BE SCRAPED TO BARE METAL AND COATED WITH NOALOX.

2.3 LIGHTNING CONSIDERATIONS

LIGHTNING DAMAGE OCCURS FROM EITHER INDUCTION OR FROM AN ACTUAL DIRECT STRIKE TO THE BUILDING, USUALLY TAKEN THROUGH THE TOWER AND/OR ANTENNAS. STRIKES TO OTHER NEARBY OBJECTS INDUCE HIGH ENERGY INTO POWER OR TELEPHONE CABLES ENTERING THE BUILDING. THIS TYPE OF EFFECT HISTORICALLY CAUSES MOST OF THE DAMAGE TO THE BUILDING AND ITS CONTENTS.

3.0 STATION GROUNDING SYSTEM

3.1 MATERIALS

- 1. #2 AWG, BARE SOLID TINNED COPPER WIRE, FOR ALL EXTERIOR CONDUCTORS AND TOWER GROUND BAR CONDUCTORS OR AS OTHERWISE SPECIFIED. GROUNDS TO THE LNAs SHALL BE NO. 6 STANDARD GREEN INSULATED JUMPERS. THE GROUND WIRE TO THE MGB SHALL BE GREEN JACKETED STRANDED #2 TINNED WIRE BURNDY CONNECTED TO THE BUSS BAR AND CONNECTED TO THE GROUND RING ON A GROUND ROD.
2. #2 AWG, INSULATED STRANDED COPPER CABLE IS ACCEPTABLE FOR INTERIOR GROUND BAR CONDUCTORS ON TENANT IMPROVEMENT SITES.
3. 5/8" X 10" GROUND RODS OF SOLID COPPER, STAINLESS STEEL OR COPPER CLAD HIGH STRENGTH STEEL.
4. ABOVE GRADE CONNECTIONS SHALL BE BURNDY HYGROUND COMPRESSION. BELOW GRADE CONNECTIONS SHALL BE AN APPROVED EXOTHERMIC WELD FOR BONDING AS SPECIFIED.
5. XIT OR ADVANCED GROUNDING ELECTRODE (AGE), ALL CHEMICAL GROUND RODS SHALL BE UL APPROVED.
6. SOLID COPPER PLATES OF MINIMUM 3'X3'X1/4" SIZE AS SPECIFIED.
7. NOALOX OR APPROVED EQUAL CONDUCTIVE MEDIUM MATERIAL SHALL BE USED IN ALL MECHANICAL CONNECTIONS.
8. #2 AWG STRANDED INSULATED (GREEN) FOR ALL INTERNAL EQUIPMENT GROUNDING.
9. MECHANICAL FASTENERS (I.E., DOUBLE LUGS, SPLIT BOLTS PARALLEL CONNECTORS) SHALL BE BRONZE, BRASS, COPPER OR STAINLESS STEEL AND HAVE NOALOX BETWEEN CONDUCTOR AND CONNECTION.
10. BOLTS, NUTS AND SCREWS USED TO FASTEN MECHANICAL CONNECTORS SHALL BE STAINLESS STEEL WITH STAR TYPE STAINLESS STEEL LOCK WASHERS.
11. ALL LUG TUBE FASTENERS SHALL PROVIDE TWO HOLES TO ALLOW A DOUBLE BOLT CONNECTION.

GROUNDING STANDARDS (CONT.):

3.2 MASTER GROUND BAR (MGB)

THE PURPOSE OF THE MASTER GROUND BAR IS TO GROUND THE BTS AND ANY OTHER METALLIC OBJECTS AROUND THE BTS. IF AN MGB IS NOT PROVIDED WITH THE BTS, THE MGB SHALL BE AS FOLLOWS: THE MGB IS A COPPER BAR MEASURING 4"W X 24"L X 1/4" LOCATED AS CLOSE TO THE BTS AS POSSIBLE. THE MGB SHALL HAVE A MINIMUM NUMBER OF (28) 3/8" HOLES. GROUND BAR SHALL BE SUPPORTED BY MOUNTING BRACKETS WITH INSULATOR STANDOFFS. (2) #2 TINNED SHALL BE MECHANICALLY ATTACHED (2-HOLE COMPRESSION LUG 3/8" HOLES, 1" CENTER TO CENTER SPACING) TO THE MGB AND DOWN LEADS THEN TAKEN THROUGH CONDUIT TO THE GROUND RING. THIS CONDUCTOR SHALL BE KEPT SEPARATE AND ISOLATED UNTIL TERMINATING AT THE MAIN GROUNDING POINT, (I.E. EXTERIOR GROUND RING OR BUILDING STEEL).

3.3 ANTENNA GROUND BAR (AGB)

THE PURPOSE OF THE ANTENNA GROUND BAR IS PRIMARILY FOR LIGHTNING PROTECTION. COAXIAL CABLE IS USUALLY THE ONLY ITEM GROUNDED TO THIS BAR. HOWEVER IT IS ACCEPTABLE TO BOND EXTERIOR; CABLE TRAY, WAVE GUIDE PORTS AND CANTILEVERED WAVE GUIDE BRIDGES TO THE AGB. THE AGB IS A COPPER BAR MEASURING 4"W X 24"L X 1/4". THERE SHALL BE TWO AGBS, ONE LOCATED AT THE TOP OF THE TOWER AT THE START OF THE VERTICAL RUN OF COAX, THE OTHER AT THE BOTTOM OF THE VERTICAL RUN OF COAX BEFORE IT MAKES ITS BEND. (IF THE TOWER IS OVER 200' THERE SHALL BE A THIRD AGB LOCATED AT HE MIDDLE OF THE TOWER).THE AGB SHALL HAVE A MINIMUM OF (28) 3/8" HOLES. GROUND BARS SHALL BE SUPPORTED BY MOUNTING BRACKETS WITH INSULATOR STANDOFFS. USE #2 AWG SOLID TINNED WIRE W/ 2-HOLE SHORT BARREL COMPRESSION LUGS 3/8" HOLES, 1" CENTER TO CENTER SPACING). THIS CONDUCTOR SHALL BE KEPT SEPARATE AND ISOLATED UNTIL TERMINATING AT THE MAIN GROUNDING POINT (I.E. EXTERIOR GROUND RING, OR BUILDING STEEL).

3.4 SURGE ARRESTOR GROUND BAR

THE PURPOSE OF THE SURGE ARRESTOR GROUND BAR IS FOR LIGHTNING PROTECTION. THE SURGE ARRESTOR GROUND BAR IS A BENT (3" X 3") X 1/4" X 24" COPPER BAR. IT IS LOCATED ON THE WAVEGUIDE BRIDGE SUPPORT CLOSEST TO THE EQUIPMENT. ONE FACE OF THE BAR SHALL HAVE A MINIMUM OF (28) 3/8" DIA. HOLES. HOLES SHALL BE IN PAIRS THAT ARE 1" CENTER TO CENTER. THE OTHER FACE SHALL HAVE 3/8" DIA. HOLES AS REQUIRED TO ATTACH AND GROUND COAXIAL SURGE ARRESTORS. THE GROUND BAR SHALL BE SUPPORTED BY MOUNTING BRACKETS WITH INSULATOR STANDOFFS.

3.5 GROUND ROD AND GROUND RING PLACEMENT

THE OUTSIDE GROUND RING SHALL BE PLACED AROUND THE BTS AT A DISTANCE OF TWO (2) FEET FROM THE BTS AT A DEPTH OF 2'-6" OR 6" BELOW THE FROST LINE, WHICHEVER IS DEEPER. RODS SHALL BE DRIVEN TO A DEPTH SUCH THAT THE TOP OF THE RODS IS AT THE LEVEL OF THE GROUND RING CONDUCTOR. THE RODS SHALL BE PLACED MINIMALLY ALONG THE RING AT THE FOLLOWING LOCATIONS:

- A. BELOW THE AREA OF THE INTERNAL MASTER GROUND BAR FOR CONNECTION TO THE MGB.
B. BELOW THE UTILITY RACK FOR CONNECTION TO THE MAIN BUILDING COMMERCIAL POWER DISCONNECT.
C. BELOW THE CORNERS OF THE BTS.
D. AS REQUIRED TO ACHIEVE A RECOMMENDED SPACING OF TWENTY (20) FEET BETWEEN GROUND RODS ALONG THE RING PERIMETER.
E. AS REQUIRED ALONG THE RING PERIMETER TO ACHIEVE 5 OHMS OR LESS RESISTANCE WHEN TESTED.
F. TWO RODS LOCATED ON OPPOSITE SIDES AT EACH TOWER LEG OR MONOPOLE.
G. ONE ROD LOCATED BENEATH EACH END OF THE WAVE GUIDE BRIDGE OR CABLE TRAY.
H. ONE ROD LOCATED AT THE BASE OF THE TOWER FOR THE TGB.

3.6 TOWER GROUNDING

ALL MONOPOLES SHALL HAVE TWO GROUND RODS (MINIMUM). ALL OTHER TOWERS SHALL HAVE TWO GROUND RODS PLACED AT THE BASE OF EACH TOWER LEG. EACH MONOPOLE OR TOWER LEG SHALL BE BONDED TO THE SYSTEM VIA TWO #2 BARE TINNED SOLID COPPER CONDUCTORS. BURNDY CONNECT THE CONDUCTORS TO ONLY STRUCTURAL BASE PLATES OR LUGS OR EARS AS MAY BE PROVIDED. NO BURNDY CONNECTIONS SHALL BE MADE TO THE VERTICAL WALLS OF THE STRUCTURE. NEVER GROUND TO HOLLOW LEG MEMBERS.

3.7 ANTENNA GROUNDING

EACH ANTENNA COAXIAL CABLE SHALL TYPICALLY BE GROUNDED AT THREE POINTS USING A HARD-SHELL COAXIAL CABLE KIT FROM THE MANUFACTURER OF THE ANTENNA CABLE. A TYPICAL INSTALLATION SHALL BE AS FOLLOWS:

- A. THE FIRST GROUND CONNECTION SHALL OCCUR AS CLOSE TO THE ANTENNA AS POSSIBLE. BELOW THE FIRST POINT THE COAX CABLE BEGINS TO RUN VERTICAL DOWN THE TOWER. THIS GROUND SHALL TERMINATE DIRECT TO THE TOP AGB. ON A T/I, GROUND TO THE AGB AT THE ANTENNA MOUNTS.
B. THE SECOND GROUND SHALL BE MADE AT THE BOTTOM OF THE VERTICAL RUN OF THE COAXIAL CABLE AS IT TURNS OUT AWAY FROM THE TOWER TOWARDS THE BTS. THIS GROUND SHALL BE TERMINATED AT THE TGB. THE TGB SHALL HAVE TWO (2) LEADS OF #2 AWG BARE TINNED SOLID COPPER WIRE, AND SHALL TERMINATE AT THE TOWER GROUND RING. THESE SHALL BE ENCASED IN PVC PIPE.

GROUNDING STANDARDS (CONT.):

- A. THE THIRD GROUND SHALL BE ON THE SURGE ARRESTOR. GROUND TO BE ATTACHED TO THE CABLE ON STRAIGHT RUNS (NOT WITHIN BENDS) AND BE WEATHERPROOFED PER THE MANUFACTURER'S SPECIFICATIONS. THE SURGE ARRESTORS SHALL BE GROUNDED TO THE GROUND BAR. THE SAGB SHALL HAVE TWO (2) LEADS OF #2 AWG BARE TINNED SOLID COPPER WIRE, AND SHALL TERMINATE AT THE TOWER GROUND RING. THESE SHALL BE ENCASED IN PVC PIPE.

3.8 PERIMETER FENCE GROUNDING

- A. ALL FENCE CORNER AND END POSTS (MINIMUM OF TWO) SHALL HAVE ONE #2 SOLID TINNED COPPER GROUND WIRE CONNECTED TO A 5/8" X 10' SOLID COPPER CLAD GROUND ROD NEXT TO THE POST. THESE POSTS SHALL BE CONNECTED TO THE GROUND RING WITH A #2 SOLID TINNED COPPER GROUND WIRE AND INTERMEDIATE GROUND RODS IF THE DISTANCE FROM THE POST TO THE GROUND RING EXCEEDS 10 FEET, IN NO CASE SHALL ANY PORTION OF THE SAME FENCE REMAIN DISCONNECTED FROM THE GROUND RING.
B. GATE POSTS SHALL BE GROUNDED TO EACH OTHER TO ENSURE THE ENTIRE FENCE HAS ELECTRICAL CONTINUITY. CONNECTIONS SHALL BE DRILL AND TAP WITH BURNDY TYPE KC22 TO THE POST WITH A #2 AWG BARE SOLID TINNED COPPER WIRE.
C. GATES SHALL BE BONDED TO GATE POSTS WITH A 18" BRAIDED STRAP TYPE BD18G92. THE CONNECTIONS SHALL BE BURNDY 2-HOLE LUGS (3/8" HOLES, 1" CENTER TO CENTER) BOLTED THROUGH EACH POST.
D. ALL DOWN LEADS TO EARTH WILL BE ENCASED IN 3/4 INCH PVC NON-METALLIC AND SEALED WITH SILICONE.

3.9 EQUIPMENT ROOM GROUNDING

THE MASTER GROUND BAR (MGB) SERVES AS THE COLLECTION POINT FOR THE BTS AS WELL AS ALL INTERIOR NON-ELECTRICAL GROUNDED METAL MATERIALS (HVAC GRILLS, DOOR FRAMES/DOORS, TELCO BOARD, UNISTRUTS, CABLE TRAYS, ALARM JUNCTION BOX, ETC..) SHALL BE GROUNDED WITH #6 AWG STRANDED (GREEN) GROUND WIRES WITH INDIVIDUAL RUNS BACK TO THE MGB. (THE CABLE TRAY, DOOR/FRAME AND UNISTRUT MAY BE JUMPERED TOGETHER AND HAVE A SINGLE GROUND WIRE CONNECTION TO THE MGB.)

3.10 WALL PENETRATIONS SLEEVES

INSTALL PER CONSTRUCTION DRAWINGS.

3.11 A/C COMMERCIAL POWER GROUNDING CONNECTIONS

AT THE ON-SITE RISER POLE LOCATION OR UNDERGROUND SERVICE ENTRANCE LOCATION, THE A/C SERVICE SHALL BE MECHANICALLY BONDED TO THE A/C SERVICE ENTRANCE GROUND AS SPECIFIED BY THE NATIONAL ELECTRIC CODE, ARTICLE 250, AND/OR APPROPRIATE LOCAL CODES. A SEPARATE GROUND ROD SHALL BE PROVIDED AT THIS POINT AND SHALL BE CONNECTED TO THE EXTERIOR GROUND RING. A SEPARATE A/C SERVICE GROUND AND NEUTRAL SHALL THEN BE ROUTED TO AND CONNECTED TO THE MAIN DISCONNECT INSIDE THE BUILDING OR AS REQUIRED BY LOCAL AUTHORITY.

3.12 COAX BRIDGE / CABLE TRAY GROUNDING

BOND THE COAX BRIDGE OR CABLE TRAY TO THE AGB WITH #2 SOLID TINNED GROUND WIRE. THESE CONNECTIONS SHALL BE DOUBLE LUG BOLTED / SCREWED MECHANICAL CONNECTIONS WITH STAR LOCK WASHERS AND NOALOX. ALL BRIDGE SPLICES SHALL HAVE JUMPERS OF #2 SOLID WITH COMPRESSION LUGS.

3.13 EXOTHERMIC WELD & BURNDY CONNECTION

EXOTHERMIC WELDS AND BURNDY CONNECTIONS SHALL BOND ALL UNDERGROUND AND DAMP LOCATION CONNECTIONS, SHELTER SKID GROUNDS, TOWER OR MONOPOLE GROUNDS, FENCING CORNER AND GATE POSTS, ANTENNA GROUND BARS, (AGB) SURGE ARRESTER GROUND BAR, AND THE MASTER GROUND BAR (MGB). MECHANICAL CONNECTIONS SHALL BE TYPICALLY USED TO BOND ALL INTERIOR EQUIPMENT, COAX CABLE BRIDGES AND COAXIAL CABLE GROUND KITS. ALL LUG TYPE MECHANICAL CONNECTORS TO THE MGB OR AGB SHALL BE TWO HOLE TYPE CONNECTED WITH STAINLESS STEEL BOLTS AND NUTS WITH STAINLESS STEEL LOCK WASHERS AND NOALOX ON EITHER SIDE OF THE BUSS BAR.

3.14 CHEMICAL GROUND RODS

CHEMICAL GROUND RODS SHALL NOT BE INSTALLED ON GROUND RING INSTALLATIONS WITH NORMAL SOIL. CHEMICAL GROUND RODS SHALL BE INSTALLED ONLY FOR SPECIAL DESIGN APPLICATIONS THAT REQUIRE SINGLE POINT GROUNDING DUE TO SPE

GROUNDING STANDARDS (CONT.):

3.15 LIMITS OF BEND RADIUS

IT IS IMPORTANT THAT THE GROUNDING CONDUCTOR CONNECTING THE INSIDE AND OUTSIDE GROUND SYSTEMS BE AS STRAIGHT AS POSSIBLE, WITH NO TURN OR BEND SHORTER THAN ONE FOOT RADIUS WITH A THREE FOOT RADIUS PREFERRED. NO RIGHT ANGLE OR SHARP BENDS SHALL BE ALLOWED.

3.16 BONDING PREPARATION & FINISH

ALL SURFACES REQUIRE PREPARATION PRIOR TO BONDING OF EITHER AN EXOTHERMIC WELD OR BURNDY FASTENERS. GALVANIZED SURFACES SHALL BE GROUND OR SANDED TO THE POINT OF EXPOSING THE STEEL SURFACE BELOW, PRIOR TO BONDING THE GROUND CONDUCTOR. FOR OTHER SURFACES INCLUDING COPPER BUSS BARS ALL PAINT, RUST TARNISH AND GREASE SHALL BE REMOVED PRIOR TO BONDING THE GROUND CONDUCTOR. EXOTHERMIC WELD TYPE BONDS SHALL BE FINISHED WITH THE APPLICATION OF COLD GALVANIZATION AND WHEN APPLICABLE, FINISH PAINTED WITH AN APPROPRIATE COLOR AS REQUIRED. MECHANICAL TYPE BONDS ON BUSS BARS SHALL BE FINISHED WITH THE APPLICATION OF NOALOX OR OTHER APPROVED CONDUCTIVE MEDIUM MATERIAL BETWEEN CONNECTOR AND BUSS BAR. MECHANICAL TYPE BONDS ON ALL OTHER SURFACES SHALL BE FINISHED WITH THE APPLICATION OF COLD GALVANIZATION AND/OR THE APPROPRIATE PAINT TO MATCH AS REQUIRED.

3.20 TESTING

THE OUTSIDE GROUND RING SHALL BE TESTED AFTER INSTALLATION BUT PRIOR TO BACKFILLING THE GROUND RING TRENCH. THE GROUND FIELD RESISTANCE SHALL MEASURE 5 OHMS OR LESS TO GROUND. ANY DIFFICULTY IN ACHIEVING THIS LEVEL OF RESISTANCE MUST BE BROUGHT TO THE ATTENTION OF THE ENGINEER. THE RESISTANCE TO GROUND SHALL BE MEASURED USING THE FALL OF POTENTIAL METHOD. TESTING SHALL BE PERFORMED BY AN OWNER PROVIDED INDEPENDENT TESTING LABORATORY FROM WHICH A WRITTEN REPORT SHALL BE PRODUCED FOR REVIEW BY THE ENGINEER.

3.21 SPECIAL CONDITIONS

WHEN SOIL CONDITIONS EXIST (I.E., NON-COMPACTABLE ROCK, GRAVEL, SHALE, ETC.) THAT PREVENTS THE INSTALLATION OF THE STANDARD GROUNDING SYSTEM AND PROCEDURES, THEN VERBAL PROCEDURES SHALL BE REQUESTED BY THE PM.

3.22 EXTERNAL GROUND RING

THE EXTERNAL GROUND RING SHALL EXTEND TO THE MAXIMUM ALLOWABLE DEPTH IN 95% COMPACTED SOIL.

3.23 GROUND RODS (REPLACEMENT)

WHEN GROUND RODS CANNOT BE DRIVEN INTO THE SOIL VERTICALLY TO A DEPTH DESCRIBED IN PARAGRAPH 3.5, AND REMAIN IN 95% COMPACTED SOIL, THEN THE FOLLOWING METHODS OF SUBSTITUTION MAY BE USED. THESE ARE SUGGESTED METHODS ONLY, AND EACH CASE SHOULD BE REVIEWED BY THE LESSEE PROJECT MANAGER. THE PURPOSE IS TO ACHIEVE THE LOWEST IMPEDANCE TO GROUND, IN ANY CASE, EQUAL TO OR LESS THAN 5 OHMS.

3.24 ROCK WITH SOME OR NO SOIL COVER

FOR SITES WHICH HAVE SOIL CONDITIONS WHICH CONSIST OF SOLID OR SEMI SOLID ROCK BELOW ABOUT THREE FEET OF COMPATIBLE SOIL, A COMBINATION OF METHODS MAY BE USED:

- A. A COMBINATION OF SHORT GROUND RODS MAY BE USED WITH 3" SQUARE 1/4" COPPER PLATES. A MINIMUM OF TWO PLATES SHOULD BE USED AND SHOULD REPLACE GROUND RODS ON AN EQUIVALENCY OF TWO GROUND ROD LENGTHS PER COPPER PLATE. THE COPPER PLATE SHOULD BE PLACED IN A MINIMUM 3" BENTONITE BASE AND COVERED WITH 3" OF BENTONITE FILL PRIOR TO BACKFILL.
B. AN ACTIVE TYPE CHEMICAL ROD SYSTEM MAY BE USED, THIS IS AN ENGINEERING JUDGMENT AND SHOULD BE USED ONLY WHERE NECESSARY, DUE TO EXPENSE. IN ALL CASES, THE STANDARD PRACTICES OUTLINED IN THIS DOCUMENT SHOULD BE FOLLOWED TO THE EXTENT THAT IS APPLICABLE, AND SHOULD BE MODIFIED AS TO THE QUANTITY OF GROUND RODS AND CONDUCTOR SIZE ONLY AS RECOMMENDED BY THE MANUFACTURER OF THE GROUND ROD SYSTEM.
C. A SYSTEM UTILIZING CORED SHAFTS, STANDARD GROUND RODS ON A TYPICAL LAYOUT, WITH A BENTONITE (CLAY) BACKFILL. IN THIS CASE EACH GROUND ROD SHOULD BE TESTED INDIVIDUALLY, AND EACH ROD SHOULD HAVE AN ACCESS BOX PLACED FOR FUTURE TESTING.

WT GROUP logo and contact information: 2675 Pratum Avenue Hoffman Estates, IL 07192, T: 224.293.6333 F: 224.293.6444, wtgroupinc.com. PROJECT NO. 321017. DANE COUNTY DEPARTMENT OF PUBLIC WORKS & TRANSPORTATION PUBLIC WORKS ENGINEERING DIVISION 1919 ALAUNT ENERGY CENTER WAY MADISON, WI 53713. DANE COUNTY EMERGENCY MANAGEMENT BUILDING 5415 KING JAMES WAY FITCHBURG, WI 53719. JEFF S. GUTOWSKY PROFESSIONAL ENGINEER LICENSE NO. 35509-006 EXPIRES: 07/31/22 SIGNED: 10/26/21. REVISIONS table with columns REV., ISSUED FOR, DATE, BY. FOR BIDDING 10/26/21 JTB.

WT GROUP logo and contact information. A list of services: AQUATIC, DESIGN & PROGRAM MANAGEMENT, CIVIL, TELECOMMUNICATION, MECHANICAL, PLUMBING, ELECTRICAL, LAND SURVEYING, ACCESSIBILITY CONSULTING, STRUCTURAL. CHECK: JKR, DRAWN: JTB, JOB: 20024707. N-2 GENERAL NOTES.

BOUNDARY & TOPOGRAPHIC SURVEY

LOTS ONE OF CERTIFIED SURVEY MAP NO. 15368, RECORDED IN THE DANE COUNTY REGISTER OF DEEDS OFFICE IN VOLUME 110 OF CERTIFIED SURVEY MAPS, PAGES 86-88, AS DOCUMENT NO. 5567984, IN THE CITY OF FITCHBURG, DANE COUNTY, WISCONSIN.



LOCATION MAP

- | | | | |
|----|--|----|---|
| 1 | RM=997.22' (STORM)
36"x18" CONCRETE STRUCTURE
INV=993.85' (18" RCP N/SSE) | 12 | RM=1000.57' (STORM)
48" CONCRETE STRUCTURE
INV=995.85' (30" RCP N)
INV=993.23' (30" RCP S) |
| 2 | RM=997.95' (STORM)
12"x12" CONCRETE STRUCTURE
INV=991.80' (48"x76" RCP N)
INV=993.55' (18" RCP S)
INV=991.80' (43"x63" RCP W) | 13 | RM=1001.59' (STORM)
48" CONCRETE STRUCTURE
INV=997.26' (30" RCP N/S) |
| 3 | RM=997.10' (STORM)
36"x18" CONCRETE STRUCTURE
INV=994.79' (18" RCP NNW)
INV=994.79' (15" PVC S) | 14 | RM=1002.81' (SANITARY)
48" CONCRETE STRUCTURE
INV=996.35' (8" PVC N/S) |
| 4 | RM=998.34' (SANITARY)
48" CONCRETE STRUCTURE
INV=993.34' (12" RCP NE/S)
INV=993.66' (8" PVC W) | 15 | RM=1005.42' (STORM)
60" CONCRETE STRUCTURE
INV=999.57' (30" RCP N/S)
INV=999.72' (18" RCP E)
INV=999.87' (18" RCP W) |
| 5 | RM=997.85' (STORM)
36"x18" CONCRETE STRUCTURE
INV=992.90' (18" RCP N) | 16 | RM=998.11' (SANITARY)
48" CONCRETE STRUCTURE
INV=994.67' (8" PVC N/E/S/W) |
| 6 | RM=997.26' (STORM)
36"x18" CONCRETE STRUCTURE
INV=993.61' (12" RCP NNW) | 17 | RM=995.13' (STORM)
84" CONCRETE STRUCTURE
INV=987.18' (36" RCP ENE)
INV=979.93' (42" RCP SSE/NNW) |
| 7 | RM=997.31' (STORM)
36"x18" CONCRETE STRUCTURE
INV=992.54' (12" RCP NNW/SSE) | 18 | RM=996.01' (STORM)
CONCRETE STRUCTURE
UNABLE TO DETERMINE SIZE
INV=987.46' (66" RCP NE/SW)
INV=989.21' (24" RCP ESE CAPPED) |
| 8 | RM=998.05' (STORM)
CONCRETE STRUCTURE
UNABLE TO DETERMINE SIZE
INV=988.55' (43"x63" RCP E)
INV=988.55' (66" RCP SW)
INV=988.65' (36" RCP NW CAPPED) | 19 | RM=997.33' (SANITARY)
48" CONCRETE STRUCTURE
INV=992.28' (15" PVC E)
INV=992.28' (12" RCP N) |
| 9 | RM=997.87' (STORM)
60" CONCRETE STRUCTURE
INV=980.45' (42" RCP SSE/NNW) | 20 | RM=999.10' (SANITARY)
48" CONCRETE STRUCTURE
INV=994.46' (12" RCP NNE/SW)
INV=995.72' (4" PVC E) |
| 10 | RM=998.51' (STORM)
36"x18" CONCRETE STRUCTURE
INV=992.68' (18" RCP WSW) | 21 | RM=1010.75' (STORM)
84" CONCRETE STRUCTURE
INV=996.20' (48" RCP N)
INV=996.20' (48"x76" RCP S) |
| 11 | RM=998.42' (STORM)
72" CONCRETE STRUCTURE
INV=990.23' (30" RCP W)
INV=990.47' (18" RCP ENE)
INV=981.23' (42" RCP SE) | | |

NOTES:

- BENCHMARK #1 - SET CROSS ON HYDRANT ON THE EAST SIDE OF KAPEC ROAD, 8' SOUTH OF THE ENTRANCE AS SHOWN. ELEVATION=1001.46' (NAVD88)
- BENCHMARK #2 - TAG BOLT ON HYDRANT ON THE SOUTH SIDE OF KING JAMES WAY, 91' SOUTHEAST OF LIGHT POLE ON THE EAST SIDE OF EAST ENTRANCE & 30' SOUTHWEST OF EXISTING MH#3. ELEVATION=1000.80' (NAVD88)
- PARCEL NUMBER: 060906399652
- THE LOCATION OF UNDERGROUND UTILITIES WAS DETERMINED BY FIELD OBSERVATION AND VISIBLE MARKINGS ONLY.
- FIELD WORK COMPLETED ON SEPTEMBER 11TH, 2020.
- SURVEY PREPARED WITHOUT THE AID OF A TITLE REPORT, REFER TO A CURRENT TITLE REPORT, DEED AND LOCAL CODES FOR ANY EASEMENT, BUILDING SETBACKS AND OTHER LOCAL RESTRICTIONS NOT SHOWN HERON. DESCRIPTION PER WARRANTY DEED DOC.#5569234
- SURVEY PREPARED FOR: PRAIRIE FORGE GROUP
- BASIS OF BEARINGS IS TRUE NORTH BASED ON ILLINOIS STATE PLANE COORDINATE SYSTEM, WISCONSIN SOUTH 4803 ZONE.
- ANY DISCREPANCIES FOUND WITHIN THIS DOCUMENT NEED TO BE REPORTED TO THE SURVEYOR AS SOON AS POSSIBLE.

STATE OF ILLINOIS)
COUNTY OF COOK)

WE THE W-T GROUP DO HEREBY DECLARE THAT WE HAVE SURVEYED THE ABOVE DESCRIBED PROPERTY AND THAT THIS PLAN IS A CORRECT REPRESENTATION OF SAID SURVEY. THIS PROFESSIONAL SERVICE CONFORMS TO THE CURRENT WISCONSIN MINIMUM STANDARDS FOR A PROPERTY AND TOPOGRAPHIC SURVEY.

GIVEN UNDER OUR HAND AND SEAL THIS 3rd DAY OF FEBRUARY 2021 AT HOFFMAN ESTATES, ILLINOIS.

THE W-T GROUP, LLC

Franjo I. Matijic
FRANJO I. MATIJIC - #S-2933-008 EXPIRES 01/31/2022
WISCONSIN PROFESSIONAL LAND SURVEYOR



WT GROUP
Engineering with Precision, Passion and Perseverance.
2075 Prairie Avenue Hoffman Estates, IL 60112
T: 224.295.0333 F: 224.295.0444
www.wtgroup.com 181.007925.0015 Email: info@wtgroup.com
© COPYRIGHT 2021 THE WT GROUP, LLC

WT Group
Engineering • Design • Consulting

EMERGENCY MANAGEMENT BUILDING
5415 KING JAMES WAY
FITCHBURG, WISCONSIN
PROJECT NO. 321017

ISSUE

TO	DATE
CLIENT	9/15/20
CLIENT	9/17/20
CLIENT	9/23/20
CLIENT	10/7/20
CLIENT	2/3/21

CHECK/FM
DRAWN/REM
JOB: 2002193S

SUR-1
SHEET 1 OF 1
BOUNDARY & TOPOGRAPHIC SURVEY

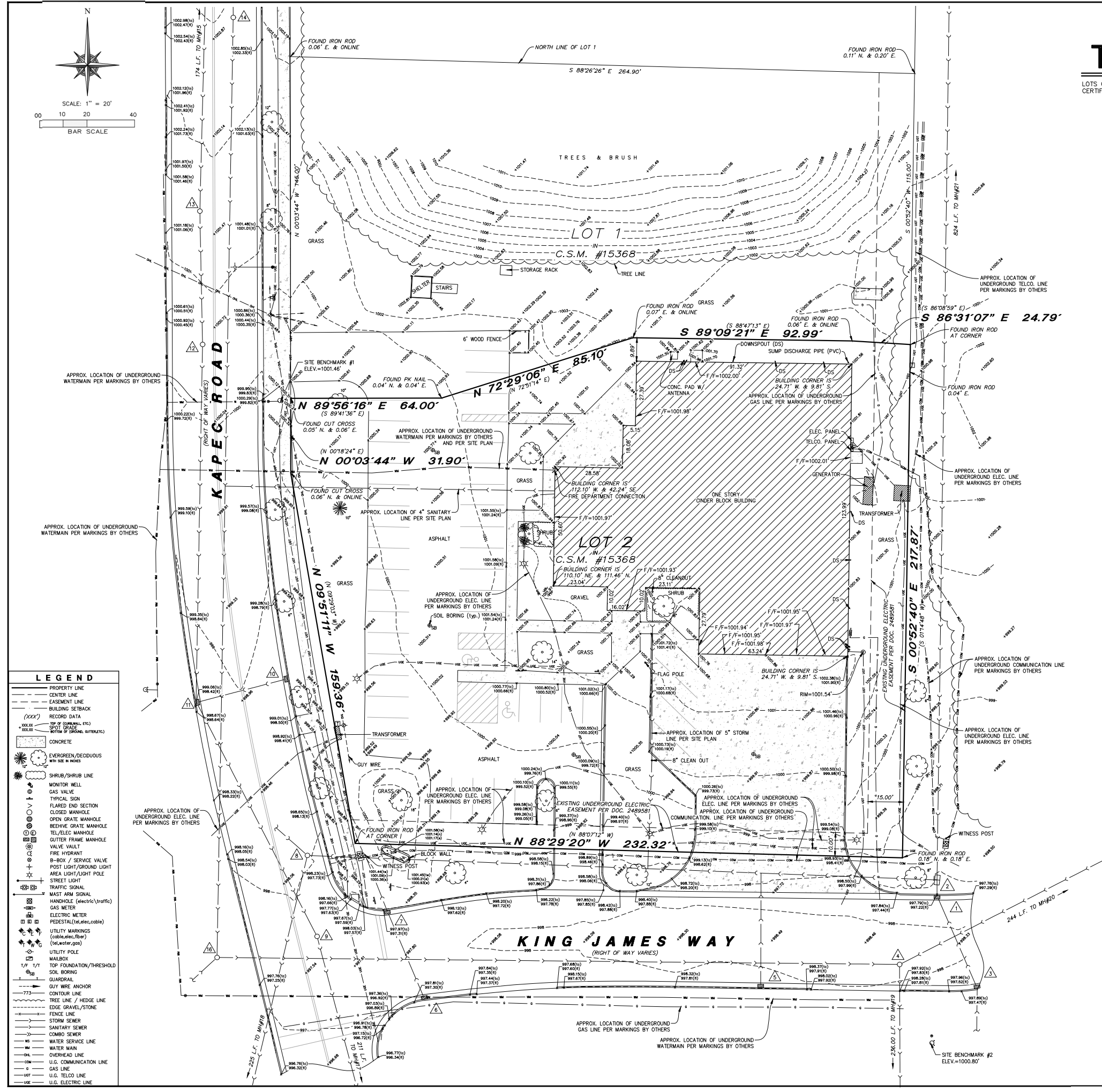

LEGEND

- PROPERTY LINE
- CENTER LINE
- EASEMENT LINE
- BUILDING SETBACK
- RECORD DATA
- SPOT GRADE
- CONCRETE
- EVERGREEN/DECIDUOUS
- SHRUB/SHRUB LINE
- MONITOR WELL
- GAS VALVE
- TYPICAL SIGN
- FLARED END SECTION
- CLOSED MANHOLE
- OPEN GRATE MANHOLE
- BEDHIVE GRATE MANHOLE
- TELE/ELC MANHOLE
- QUITTER FRAME MANHOLE
- VALVE VAULT
- FIRE HYDRANT
- B-BOX / SERVICE VALVE
- POST LIGHT/GROUND LIGHT
- AREA LIGHT/LIGHT POLE
- STREET LIGHT
- TRAFFIC SIGNAL
- MAST ARM SIGNAL
- HANDLEHOLE (electric, traffic)
- GAS METER
- ELECTRIC METER
- PEDESTAL (tel, elec, cable)
- UTILITY MARKINGS (cable, elec, fiber) (tel, water, gas)
- UTILITY POLE
- MAILBOX
- TOP FOUNDATION/THRESHOLD
- SOIL BORING
- GUARDRAIL
- GUY WIRE ANCHOR
- CONTOUR LINE
- TREE LINE / HEDGE LINE
- EDGE GRAVEL/STONE
- FENCE LINE
- STORM SEWER
- SANITARY SEWER
- COMBO SEWER
- WATER SERVICE LINE
- WATER MAIN
- OVERHEAD LINE
- U.G. COMMUNICATION LINE
- GAS LINE
- U.G. TELCO LINE
- U.G. ELECTRIC LINE

IMPORTANT SITE NOTES:

1. CONTRACTOR WILL NOT START CONSTRUCTION UNTIL AFTER THEY HAVE RECEIVED THE PRE-CON PACKAGE AND HAVE A PRE-CON WALK WITH THE PROJECT MANAGER.
2. CONTRACTOR TO HIRE PUBLIC (811) AND PRIVATE LOCATING SERVICE IN ORDER TO LOCATE AND PROTECT ALL SUB-SURFACE UTILITIES. DO NOT SCALE OFF THESE PLANS FOR ANY BELOW GRADE UTILITIES.
3. CONTRACTOR SHALL VERIFY ALL EXISTING BURIED AND OVERHEAD UTILITIES PRIOR TO EXCAVATION. CONTRACTOR SHALL REPAIR ALL DAMAGED UTILITIES AT HIS OWN COST AND COORDINATE ANY REPAIRS WITH RESPECTIVE UTILITY COMPANY.
4. CONTRACTOR TO VERIFY ALL HEIGHTS AND AZIMUTHS IN FIELD PRIOR TO CONSTRUCTION. CONTRACTOR SHALL NOTIFY CARRIER AND ENGINEERING FIRM OF ANY DISCREPANCIES BEFORE PROCEEDING.
5. CONTRACTOR SHALL RESTORE AND REPAIR ANY DAMAGED AREAS CAUSED BY CONSTRUCTION.

NOTE:

1. PROJECT MANAGER SHALL COORDINATE WITH THE PROPERTY OWNER TO OBTAIN THE PROPER EASEMENT AGREEMENTS TO CONSTRUCT AND MAINTAIN EQUIPMENT IN AND AROUND THE SITE.
2. PROPOSED LAYOUT BASED ON SURVEY PROVIDED BY WT GROUP, LLC DATED 10/07/2020.

TOWER DISTANCE TO PROPERTY LINES (FROM TOWER CENTER)

	PROVIDED
NORTH	57'-0"
WEST	243'-0"
EAST	15'-0"
SOUTH	161'-0"

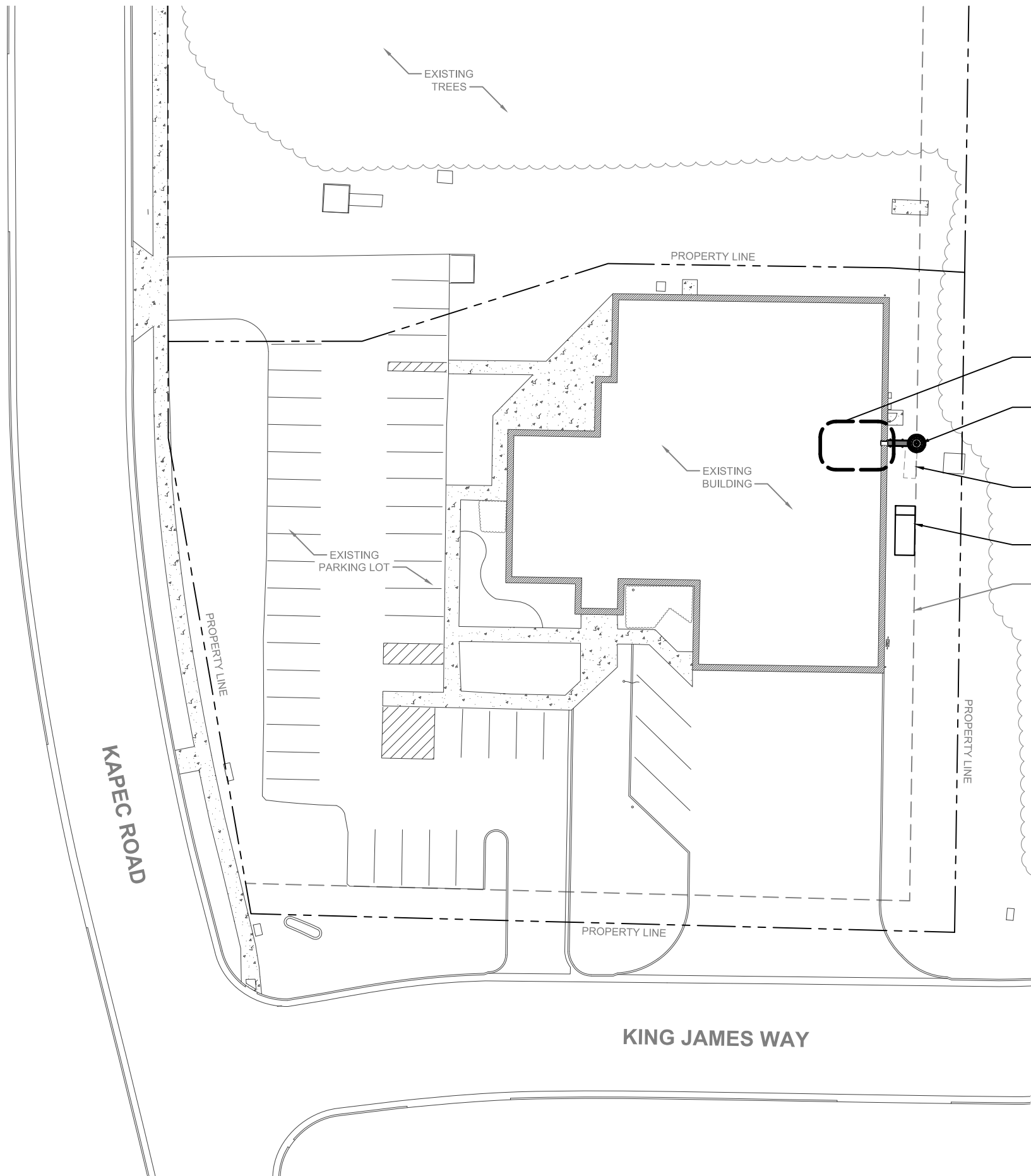

- NEW EQUIPMENT ROOM (BY OTHERS)
- NEW 70'-0" MONOPOLE. SEE A-1
- EXISTING GENERATOR & CONCRETE PAD TO BE REMOVED (BY OTHERS)
- NEW GENERATOR ON CONCRETE PAD (BY OTHERS)
- EXISTING 15'-0" UTILITY EASEMENT

DANE COUNTY DEPARTMENT OF PUBLIC WORKS & TRANSPORTATION
PUBLIC WORKS ENGINEERING DIVISION
1919 ALJANT ENERGY CENTER WAY
MADISON, WI 53713



PROJECT NO. 321017

DANE COUNTY EMERGENCY MANAGEMENT BUILDING
5415 KING JAMES WAY
FITCHBURG, WI 53719



JEFF GUTOWSKY, P.E.; S.E.
WI LICENSE NO. 35509-6
EXPIRES: 07/31/22 SIGNED: 10/26/21

REVISIONS

REV.	ISSUED FOR	DATE	BY
Δ	FOR BIDDING	10/26/21	JTB

AQUATIC \ DESIGN & PROGRAM MANAGEMENT
CIVIL \ TELECOMMUNICATION \ MECHANICAL
PLUMBING \ ELECTRICAL \ LAND SURVEYING
ACCESSIBILITY CONSULTING \ STRUCTURAL

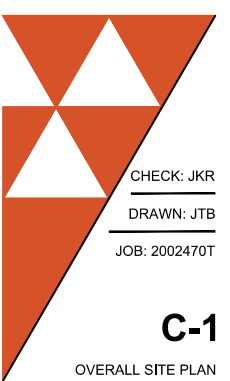

C-1

OVERALL SITE PLAN

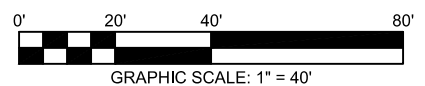

OVERALL SITE PLAN

SCALE: 1" = 40'-0"

1



WT GROUP
Engineering with Precision, Pace and Passion.
2875 Pratum Avenue Hoffman Estates, IL 60192
T: 224-293-6333 F: 224-293-6444
wtgroupinc.com

WT Group
Engineering • Design • Consulting

© COPYRIGHT 2021 THE WT GROUP, LLC

NOTE:
 1. PROJECT MANAGER SHALL COORDINATE WITH THE PROPERTY OWNER TO OBTAIN THE PROPER EASEMENT AGREEMENTS TO CONSTRUCT AND MAINTAIN EQUIPMENT IN AND AROUND THE SITE.
 2. PROPOSED LAYOUT BASED ON SURVEY PROVIDED BY WT GROUP, LLC DATED 10/07/2020.

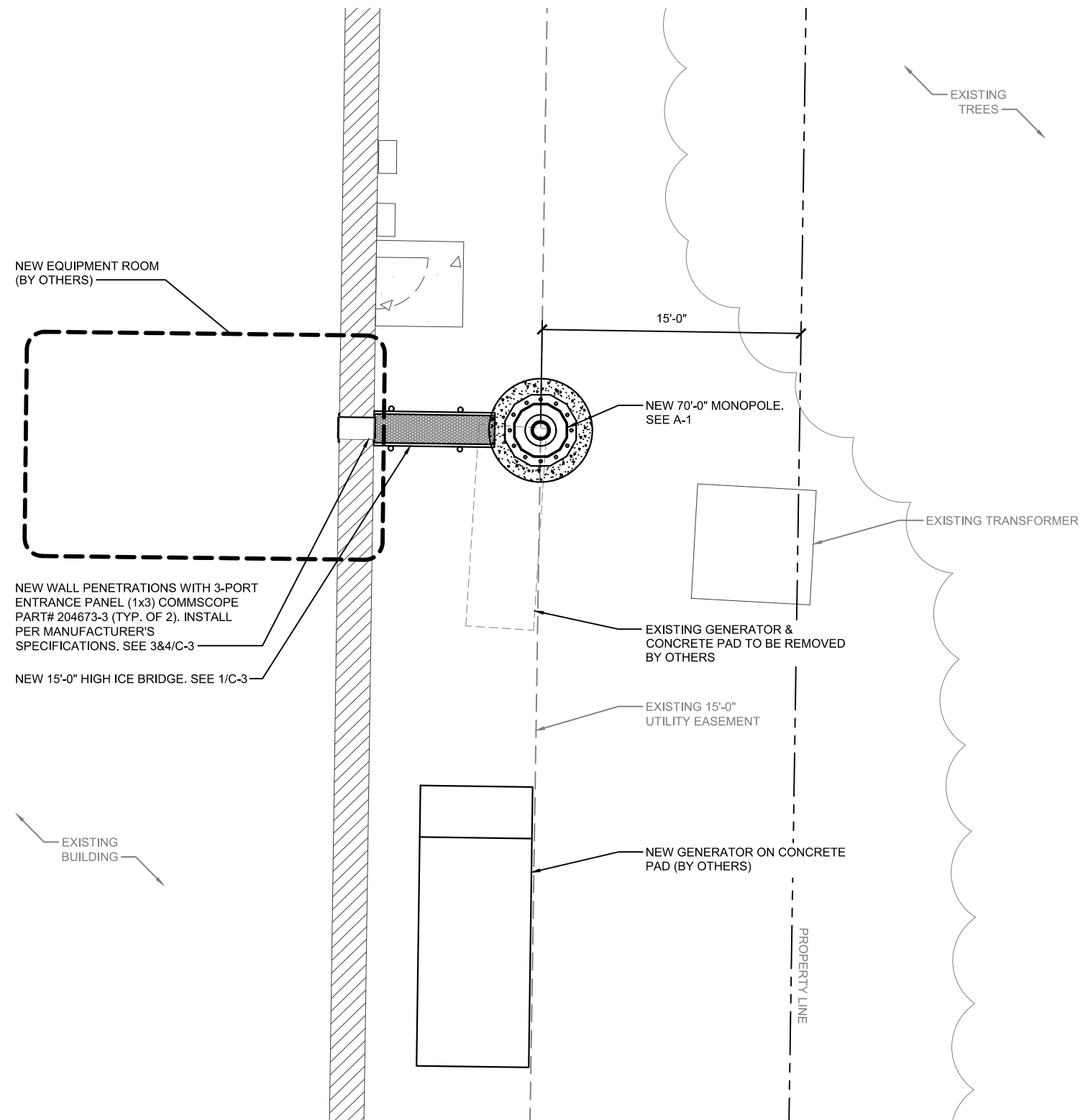

ENLARGED SITE PLAN

SCALE: 1/8" = 1'-0"

1



DANE COUNTY DEPARTMENT OF PUBLIC WORKS & TRANSPORTATION
 PUBLIC WORKS ENGINEERING DIVISION
 1919 ALJANT ENERGY CENTER WAY
 MADISON, WI 53713

WT GROUP
 Engineering with Precision, Pace and Passion.
 2675 Prichard Avenue Hoffman Estates, IL 00192
 T: 224-293-6333 F: 224-293-6444
 wtgroup.com

WT Group
 Engineering • Design • Consulting

PROJECT NO. 321017

DANE COUNTY EMERGENCY MANAGEMENT BUILDING
 5415 KING JAMES WAY
 FITCHBURG, WI 53719

© COPYRIGHT 2021 THE WT GROUP, LLC



JEFF GUTOWSKY, P.E.; S.E.
 WI LICENSE NO. 35509-6
 EXPIRES: 07/31/22 SIGNED: 10/26/21

REV.	ISSUED FOR	DATE	BY
1	FOR BIDDING	10/26/21	JTB

AQUATIC \ DESIGN & PROGRAM MANAGEMENT
 CIVIL \ TELECOMMUNICATION \ MECHANICAL
 PLUMBING \ ELECTRICAL \ LAND SURVEYING
 ACCESSIBILITY CONSULTING \ STRUCTURAL

CHECK: JKR
 DRAWN: JTB
 JOB: 2002470T

C-2
 ENLARGED SITE PLAN

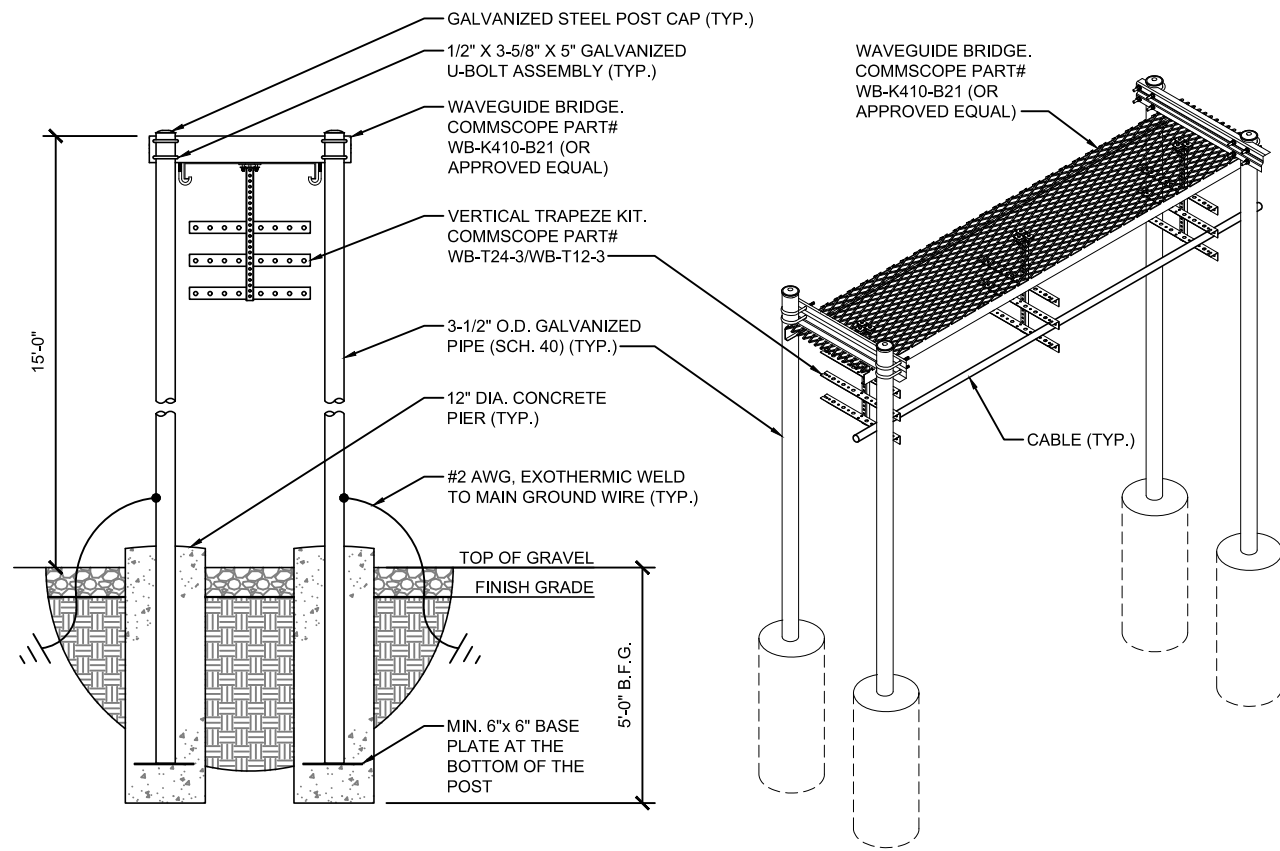

ICE BRIDGE DETAIL
SCALE: NONE

1

NOT USED
SCALE: NONE

2

U.L. SYSTEM NO. C-AJ-1150
CONDUIT THROUGH BEARING WALL SIMILAR TO U.L. DESIGN NO. U902
F RATING = 3-HR.
T RATING = 0-HR.

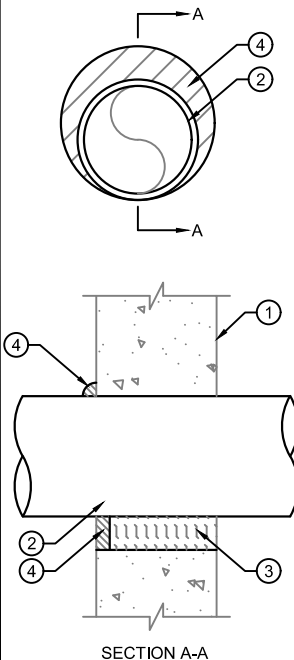

- FLOOR OR WALL ASSEMBLY -- MINIMUM 4-1/2" THICK REINFORCED LIGHTWEIGHT OR NORMAL WEIGHT (100-150 PCF) CONCRETE. WALL MAY ALSO BE CONSTRUCTED OF ANY UL CLASSIFIED CONCRETE BLOCKS *. MAX DIAMETER OF OPENING IS 8". SEE CONCRETE BLOCKS (CAZT) CATEGORY IN THE FIRE RESISTANCE DIRECTORY FOR NAMES OF MANUFACTURERS.
- THROUGH PENETRATIONS -- ONE METALLIC PIPE OR CONDUIT TO BE INSTALLED WITHIN THE FIRESTOP SYSTEM. PIPE OR CONDUIT TO BE RIGIDLY SUPPORTED ON BOTH SIDES OF FLOOR OR WALL ASSEMBLY. THE ANNULAR SPACE SHALL BE MINIMUM 0". (POINT CONTACT) TO MAXIMUM 1-3/8". THE FOLLOWING TYPES AND SIZES OF METALLIC PIPES OR CONDUITS MAY BE USED:
A. STEEL PIPE -- NOMINAL 6" DIAMETER (OR SMALLER) SCHEDULE 40 (OR HEAVIER) STEEL PIPE.
B. IRON PIPE -- NOMINAL 6" DIAMETER (OR SMALLER) CAST OR DUCTILE IRON PIPE.
C. CONDUIT -- NOMINAL 4" DIAMETER (OR SMALLER) STEEL ELECTRICAL METALLIC TUBING OR NOMINAL 6" DIAMETER (OR SMALLER) STEEL CONDUIT.
- PACKING MATERIAL -- MINIMUM 4" THICKNESS OF MIN 4.0 PCF MINERAL WOOL BATTING INSULATION FIRMLY PACKED INTO OPENING AS A PERMANENT FORM. PACKING MATERIAL TO BE RECESSED FROM TOP SURFACE OF FLOOR OR FROM BOTH SURFACES OF WALL AS REQUIRED TO ACCOMMODATE THE REQUIRED THICKNESS OF FILL MATERIAL.
- FILL, VOID, OR CAVITY MATERIAL* -- SEALANT -- MINIMUM 1/4" THICKNESS OF FILL MATERIAL APPLIED WITHIN THE ANNULUS, FLUSH WITH TOP SURFACE OF FLOOR AND WITH BOTH SURFACES OF WALL. AT THE POINT CONTACT LOCATION BETWEEN PIPE AND CONCRETE, A MINIMUM 1/2" DIAMETER BEAD OF FILL MATERIAL SHALL BE APPLIED AT THE CONCRETE/PIPE INTERFACE ON THE TOP SURFACE OF FLOOR AND ON BOTH SURFACES OF WALL. W RATING APPLIES ONLY WHEN CP601S OR CP604 SEALANT IS USED.
HILTI CONSTRUCTION CHEMICALS, DIV OF HILTI INC -- CP601S, CP604, CP606 OR FS-ONE SEALANT
*BEARING THE UL CLASSIFICATION MARK

- NOTES:
- USE GROUND PENETRATING RADAR PRIOR TO CORE DRILLING. NO CUTTING/DAMAGING OF EXISTING REBAR IS ALLOWED.
 - MAXIMUM DIAMETER OF OPENING = 8"
 - ANNULAR SPACE = MINIMUM 0", MAXIMUM 2"
 - MINIMUM 1/4" DEPTH OF HILTI CP 601S ELASTOMERIC FIRESTOP SEALANT IS REQUIRED ON EACH SIDE OF A WALL ASSEMBLY.

NOTE:
IF EXISTING CONSTRUCTION VARIES FROM THIS DETAIL, AN EQUAL 3-HOUR U.L. PENETRATION APPROPRIATE FOR THE EXISTING WALL TYPE SHALL BE CONSTRUCTED

WALL/FLOOR PENETRATION DETAIL
SCALE: NONE

3

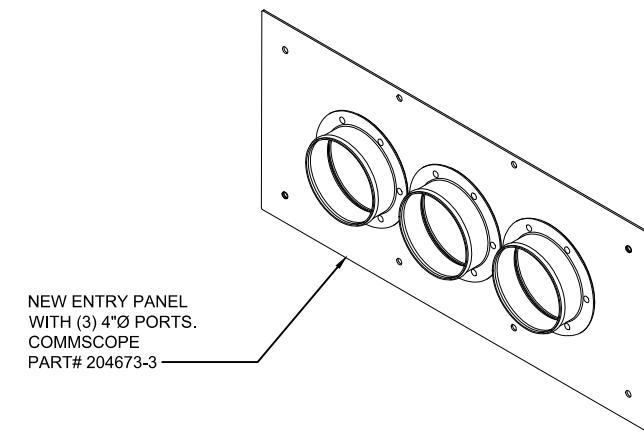

NEW 4" BOOT ASSEMBLY KIT. COMMSCOPE PART# 294573 (INSTALL INDIVIDUAL BOOTS AS NEEDED, UNUSED PORTS TO BE CAPPED)

SEE 3/C-3 FOR WALL PENETRATION DETAIL

COAX ENTRY PORT & BOOT DETAIL
SCALE: NONE

4

WT GROUP
Engineering with Precision, Pace and Passion.
2675 Prichard Avenue Hoffman Estates, IL 60192
T: 224-293-6333 | F: 224-293-6444
wtgroup.com

WT Group
Engineering • Design • Consulting

DANE COUNTY DEPARTMENT OF PUBLIC WORKS & TRANSPORTATION
PUBLIC WORKS ENGINEERING DIVISION
1919 ALJANT ENERGY CENTER WAY
MADISON, WI 53713

PROJECT NO. 321017

DANE COUNTY EMERGENCY MANAGEMENT BUILDING
5415 KING JAMES WAY
FITCHBURG, WI 53719

JEFF S. GUTOWSKY
3509-006
PROFESSIONAL ENGINEER

JEFF GUTOWSKY, P.E.; S.E.
WI LICENSE NO. 35509-6
EXPIRES: 07/31/22 SIGNED: 10/26/21

REV.	ISSUED FOR	DATE	BY
1	FOR BIDDING	10/26/21	JTB

AQUATIC \ DESIGN & PROGRAM MANAGEMENT
CIVIL \ TELECOMMUNICATION \ MECHANICAL
PLUMBING \ ELECTRICAL \ LAND SURVEYING
ACCESSIBILITY CONSULTING \ STRUCTURAL

CHECK: JKR
DRAWN: JTB
JOB: 2002470T

C-3
SITE DETAILS

NOTE:
 W-T'S SCOPE OF WORK DOES NOT INCLUDE A STRUCTURAL EVALUATION OF THIS TOWER OR STRUCTURE. NEW ANTENNAS AND EQUIPMENT SHOWN ON THIS PLAN HAVE NOT BEEN EVALUATED TO VERIFY THE TOWER OR STRUCTURE HAS THE CAPACITY TO ADEQUATELY SUPPORT THESE ANTENNAS. PRIOR TO ANY ANTENNA OR EQUIPMENT INSTALLATION, A STRUCTURAL EVALUATION SHALL BE PERFORMED OF THE TOWER AND WILL BE PROVIDED BY THE TOWER MANUFACTURER, INCLUDING ALL ANTENNA MOUNTING SYSTEMS & HARDWARE.

NOTE:
 PRIOR TO CONSTRUCTION, CONTRACTOR TO VERIFY & INSTALL FAA REQ'S FOR TOWER LIGHTING.

NOTE:
 TOWERLOADING DEPICTED DRAWING SHOW MAXIMUM NUMBER OF ANTENNAS. CONTRACTOR TO VERIFY WITH EMERGENCY MANAGEMENT PRIOR TO INSTALLATION.

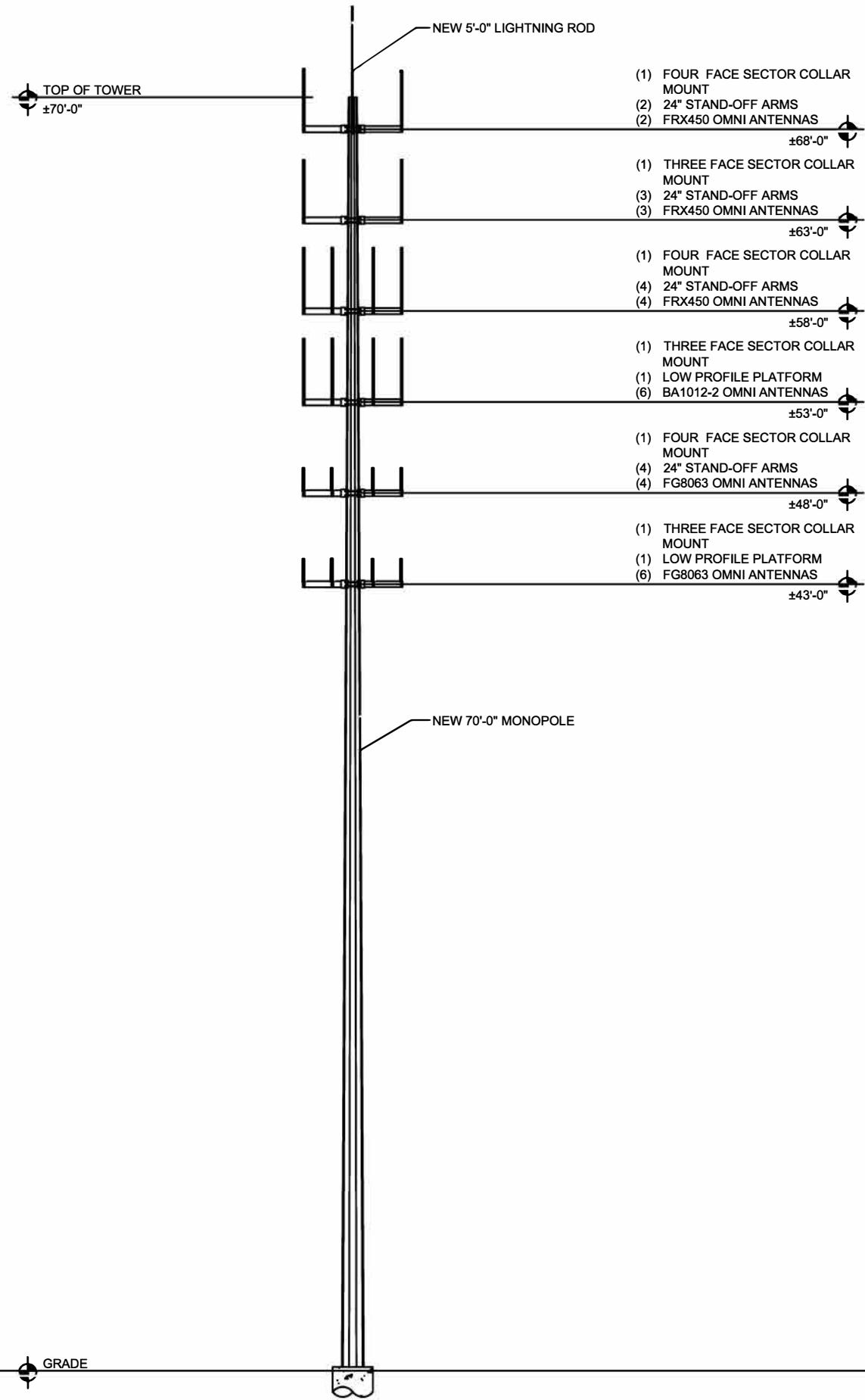

ELEVATION	1
SCALE: 1/8" = 1'-0"	

WT GROUP
 Engineering with Precision, Pace and Passion.
 2676 Prilum Avenue Hoffman Estates, IL 60192
 T: 224-293-6333 F: 224-293-6444
 wtgroup.com

WT Group
 Engineering • Design • Consulting

DANE COUNTY DEPARTMENT OF PUBLIC WORKS & TRANSPORTATION
 PUBLIC WORKS ENGINEERING DIVISION
 1919 ALJANT ENERGY CENTER WAY
 MADISON, WI 53713

PROJECT NO. 321017

DANE COUNTY EMERGENCY MANAGEMENT BUILDING
 6415 KING JAMES WAY
 FITCHBURG, WI 53719



JEFF GUTOWSKY, P.E.; S.E.
 WI LICENSE NO. 35509-6
 EXPIRES: 07/31/22 SIGNED: 10/26/21

REV.	ISSUED FOR	DATE	BY
▲	FOR BIDDING	10/26/21	JTB

AQUATIC \ DESIGN & PROGRAM MANAGEMENT
 CIVIL \ TELECOMMUNICATION \ MECHANICAL
 PLUMBING \ ELECTRICAL \ LAND SURVEYING
 ACCESSIBILITY CONSULTING \ STRUCTURAL

CHECK: JKR
 DRAWN: JTB
 JOB: 2002470T

A-1
 ELEVATION

NOTE:
GROUNDING IS FOR REFERENCE ONLY. SOIL
CONDITIONS SPECIFIED IN GEOTECHNICAL REPORT
SHALL BE REFERRED TO PRIOR TO CONSTRUCTION
& MATERIAL ORDER. FINAL GROUNDING SYSTEM
RESISTANCE TO BE UNDER 5 OHM'S.

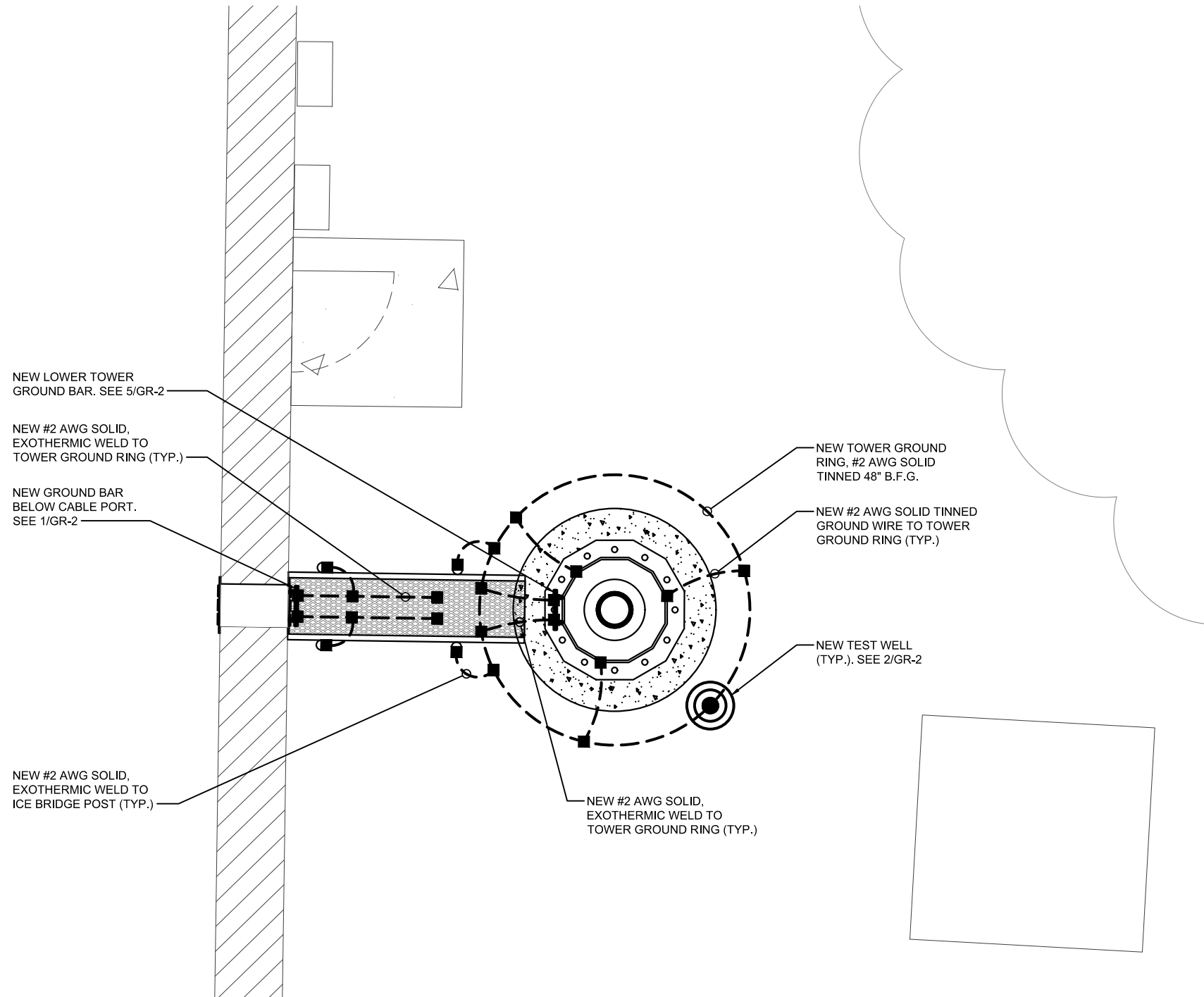

LEGEND	
---	GROUNDING WIRE
■	EXOTHERMIC WELD
□	MECHANICAL CONNECTION
▲	COMPRESSION FITTING
◎	TEST WELL
○	GROUND ROD
⊞	GROUND BUS BAR

WT GROUP
 Engineering with Precision, Pace and Passion.
 2675 Prichard Avenue Hoffman Estates, IL 60192
 T: 224-293-6333 | F: 224-293-6444
 wtgroup.com

WT Group
 Engineering • Design • Consulting

DANE COUNTY DEPARTMENT OF PUBLIC
 WORKS & TRANSPORTATION
 PUBLIC WORKS ENGINEERING DIVISION
 1919 ALJANT ENERGY CENTER WAY
 MADISON, WI 53713

PROJECT NO. 321017

**DANE COUNTY EMERGENCY
 MANAGEMENT BUILDING**
 5415 KING JAMES WAY
 FITCHBURG, WI 53719

JEFF S. GUTOWSKY, P.E.; S.E.
 WI LICENSE NO. 35509-6
 EXPIRES: 07/31/22 SIGNED: 10/26/21

REVISIONS

REV.	ISSUED FOR	DATE	BY
▲	FOR BIDDING	10/26/21	JTB

AQUATIC \ DESIGN & PROGRAM MANAGEMENT
 CIVIL \ TELECOMMUNICATION \ MECHANICAL
 PLUMBING \ ELECTRICAL \ LAND SURVEYING
 ACCESSIBILITY CONSULTING \ STRUCTURAL

CHECK: JKR
 DRAWN: JTB
 JOB: 2002470T

GR-1
 GROUNDING PLAN



GROUNDING PLAN

SCALE: 1/4" = 1'-0"

1



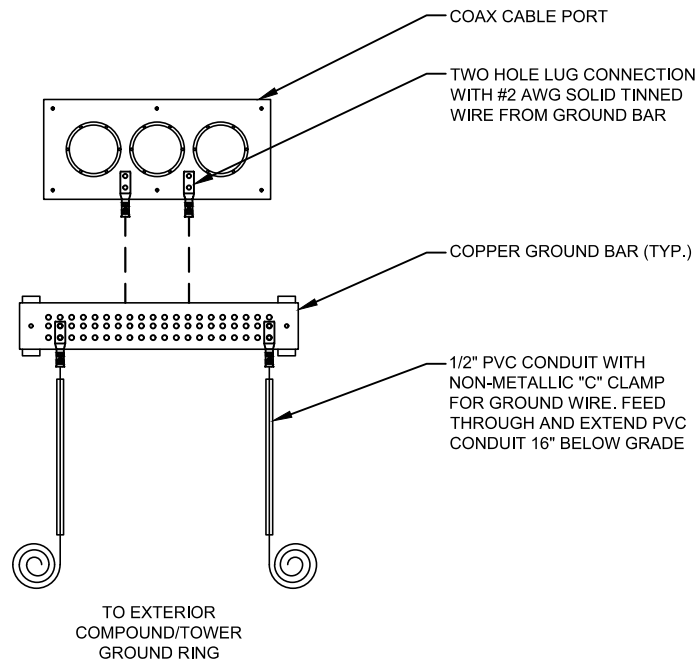

CABLE PORT DETAIL

1

SCALE: NONE

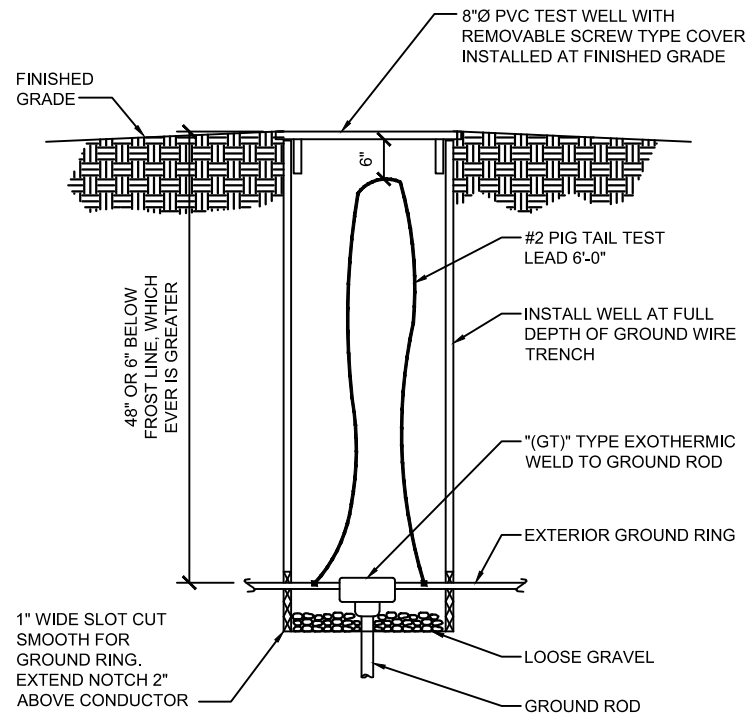

TEST WELL DETAIL

2

SCALE: NONE

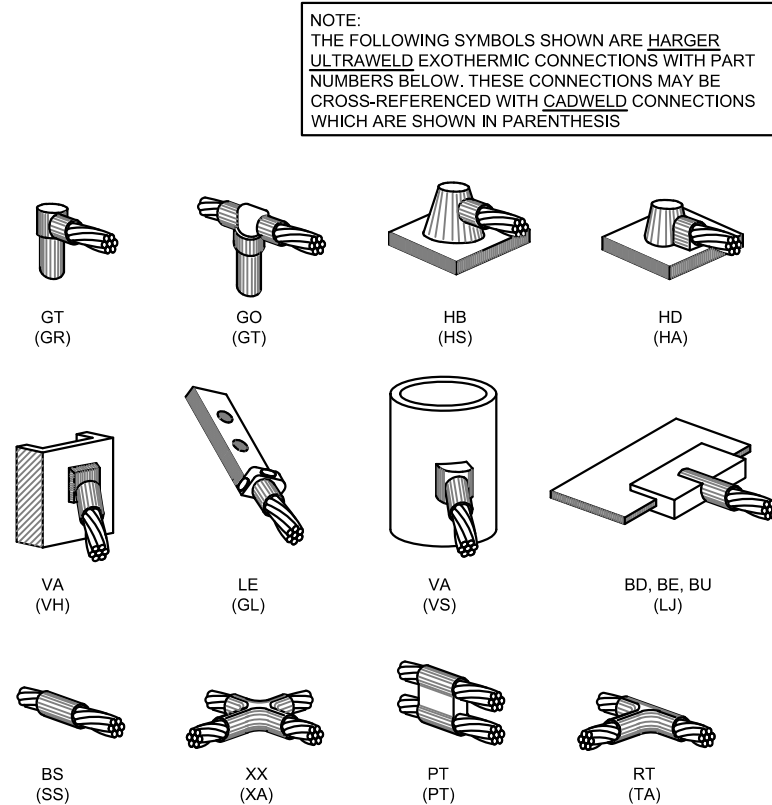

EXOTHERMIC WELD TYPES

3

SCALE: NONE

NOTE:
THE FOLLOWING SYMBOLS SHOWN ARE HARGER
ULTRAWELD EXOTHERMIC CONNECTIONS WITH PART
NUMBERS BELOW. THESE CONNECTIONS MAY BE
CROSS-REFERENCED WITH CADWELD CONNECTIONS
WHICH ARE SHOWN IN PARENTHESIS

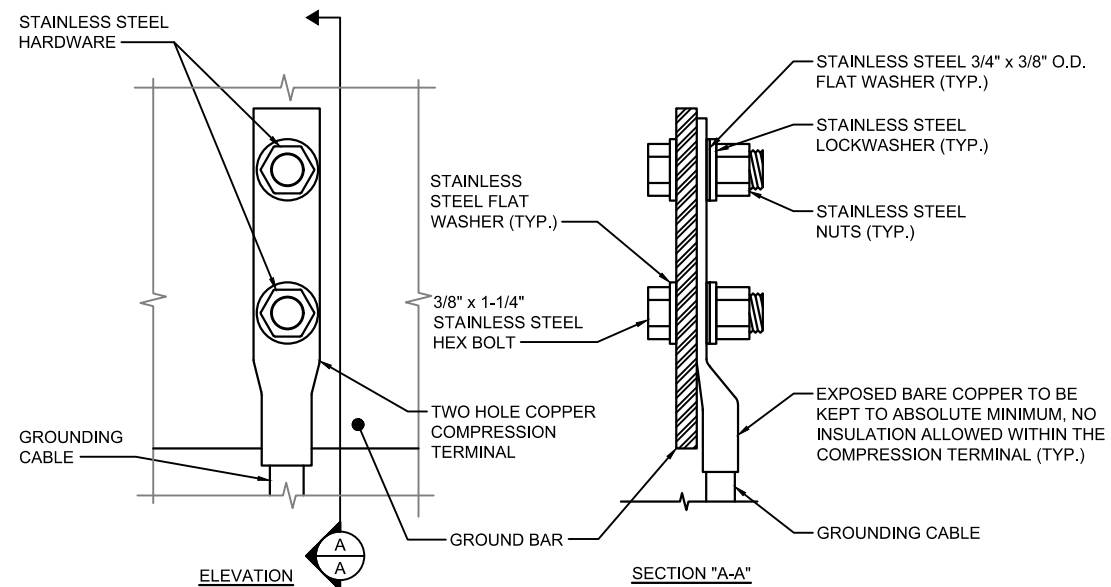

GROUND BAR CONNECTION DETAIL

4

SCALE: NONE

- OXIDE INHIBITING COMPOUND TO BE USED AT ALL LOCATIONS
- NO CRIMPING OF SOLID #2. USE EXOTHERMIC WELD ONLY

KEY NOTES:

1.	1/4" THK ELECTRICAL TINNED GROUND BAR HARGER OR APPROVED EQUAL. HOLE CENTERS TO MATCH NEMA DOUBLE LUG CONFIGURATION
2.	INSULATORS (UNLESS NOTED OTHERWISE)
3.	3/8" STAINLESS STEEL LOCKWASHERS
4.	WALL MOUNTING BRACKET
5.	3/8" STAINLESS STEEL BNLF BOLTS
6.	EXOTHERMICALLY WELD #2 AWG BARE TINNED SOLID COPPER CONDUCTOR TO GROUND BAR. ROUTE CONDUCTOR TO BURIED GROUND RING AND PROVIDE PARALLEL EXOTHERMIC WELD
7.	CONTRACTOR SHALL USE PERMANENT MARKER TO DRAW THE LINES BETWEEN EACH SECTION AND LABEL EACH SECTION ("P", "A", "N", "I") WITH 1" HIGH LETTERS

EACH GROUND CONDUCTOR TERMINATING ON ANY GROUND BAR SHALL HAVE AN IDENTIFICATION TAG ATTACHED AT EACH END THAT WILL IDENTIFY ITS ORIGIN AND DESTINATION

SECTION "P" - SURGE PRODUCERS

- COLLECTOR GROUND BAR
- GENERATOR FRAMEWORK (IF AVAILABLE)
- TELCO GROUND BAR
- COMMERCIAL POWER COMMON NEUTRAL/GROUND BOND
- FIBER GROUND BAR
- EQUIPMENT ROOM COLLECTOR GROUND BAR
- HVAC
- RECTIFIER FRAMES

SECTION "I" - ISOLATED GROUND ZONE

- ISOLATED EQUIPMENT FRAMES
- ISOLATED GROUND BAR - IGB

NOTES:
-EXTERIOR GROUND BARS TO BE TIN PLATED
-HARDWARE SHALL BE STAINLESS STEEL
-CONTRACTOR SHALL GROUP INCOMING WIRES
-CONTRACTOR TO APPLY 'KOPR-SHIELD' TO ALL CONNECTIONS

NOTE:
CONTRACTOR TO INSTALL/REPLACE NEW OR MISSING GROUND BARS AS REQUIRED.

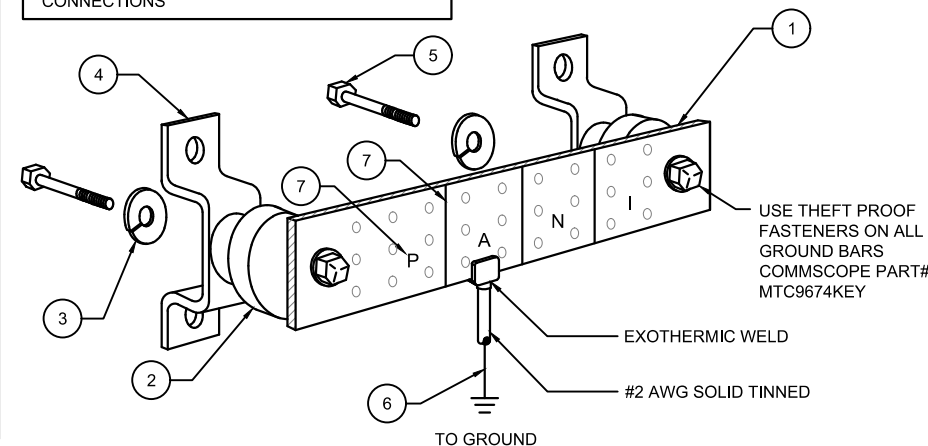

SECTION "A" - SURGE ABSORBERS

- INTERIOR GROUND RING
- EXTERNAL EARTH GROUND FIELD (BURIED GROUND RING)
- METALLIC COLD WATER PIPE (IF AVAILABLE)
- BUILDING STEEL (IF AVAILABLE)
- AC POWER

SECTION "N" - NON-ISOLATED GROUND ZONE EQUIPMENT

- MISCELLANEOUS NON-ISOLATED GROUND ZONE EQUIPMENT
- CABLE TRAY SYSTEM
- EQUIPMENT FRAMES
- BATTERY RACKS
- DC POWER

GROUND BAR DETAIL

5

SCALE: NONE

WT GROUP
Engineering with Precision, Pace and Passion.
2675 Prichard Avenue Hoffman Estates, IL 00192
T: 224-293-6333 | F: 224-293-6444
wtengineering.com

WT Group
Engineering • Design • Consulting

DANE COUNTY DEPARTMENT OF PUBLIC WORKS & TRANSPORTATION
PUBLIC WORKS ENGINEERING DIVISION
1919 ALJANT ENERGY CENTER WAY
MADISON, WI 53713

PROJECT NO. 321017

DANE COUNTY EMERGENCY MANAGEMENT BUILDING
5415 KING JAMES WAY
FITCHBURG, WI 53719

JEFF S. GUTOWSKY
35509-006
PROFESSIONAL ENGINEER

JEFF GUTOWSKY, P.E.; S.E.
WI LICENSE NO. 35509-6
EXPIRES: 07/31/22 SIGNED: 10/26/21

REVISIONS	REV.	ISSUED FOR	DATE	BY
FOR BIDDING			10/26/21	JTB

USE THEFT PROOF FASTENERS ON ALL GROUND BARS COMMSCOPE PART# MTC9674KEY

AQUATIC \ DESIGN & PROGRAM MANAGEMENT
CIVIL \ TELECOMMUNICATION \ MECHANICAL
PLUMBING \ ELECTRICAL \ LAND SURVEYING
ACCESSIBILITY CONSULTING \ STRUCTURAL

CHECK: JKR
DRAWN: JTB
JOB: 2002470T

GR-2
GROUNDING DETAILS