

RFB NO. 316001

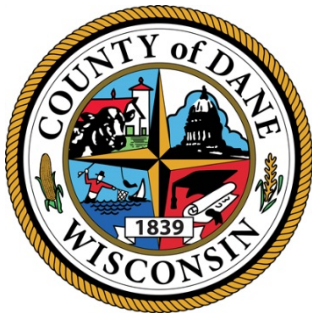

CONSTRUCTION DOCUMENTS PROJECT MANUAL

DANE COUNTY DEPARTMENT OF PUBLIC WORKS,
HIGHWAY AND TRANSPORTATION

PUBLIC WORKS ENGINEERING DIVISION
1919 ALLIANT ENERGY CENTER WAY
MADISON, WISCONSIN 53713

REQUEST FOR BIDS NO. 316001 COLISEUM LOADING DOCKS ALLIANT ENERGY CENTER 1919 ALLIANT ENERGY CENTER WAY MADISON, WISCONSIN

Due Date / Time: **TUESDAY, FEBRUARY 23, 2016 / 2:00 P.M.**

Location: **PUBLIC WORKS OFFICE**

Performance / Payment Bond: **100% OF CONTRACT AMOUNT**

Bid Deposit: **5% OF BID AMOUNT**

FOR INFORMATION ON THIS REQUEST FOR BIDS, PLEASE CONTACT:

J. ERIC URTE, AIA, PROJECT MANAGER

TELEPHONE NO.: 608/266-4798

FAX NO.: 608/267-1533

E-MAIL: urtes.eric@countyofdane.com

SEALS PAGE

BID NO. 316001

PROJECT: COLISEUM LOADING DOCKS ALLIANT ENERGY CENTER
ALLIANT ENERGY CENTER

ARCHITECT

I hereby certify that this drawing, specification or report was prepared by me or under my direct supervision and that I am a duly Registered Architect under the laws of the State of Wisconsin.



Dated: February 4, 2016

A. James Gersich – Registration No. 3961

SEALS PAGE

BID NO. 316001

PROJECT: COLISEUM LOADING DOCKS ALLIANT ENERGY CENTER
ALLIANT ENERGY CENTER

STRUCTURAL ENGINEER

I hereby certify that this drawing, specification or report was prepared by me or under my direct supervision and that I am a duly Registered Professional Engineer under the laws of the State of Wisconsin.



M. Leiferman

Michael R. Leiferman - Registration No. 33478

Dated: February 4, 2016

SEALS PAGE

BID NO. 316001

**PROJECT: COLISEUM LOADING DOCKS ALLIANT ENERGY CENTER
ALLIANT ENERGY CENTER**

PLUMBING ENGINEER

I hereby certify that this drawing, specification or report was prepared by me or under my direct supervision and that I am a duly Registered Professional Engineer under the laws of the State of Wisconsin.

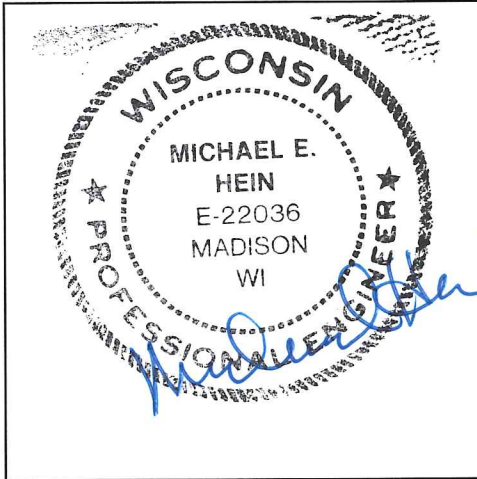

Michael Edward Hein - Registration No. 22036

Dated: February 4, 2016

ELECTRICAL ENGINEER

I hereby certify that this drawing, specification or report was prepared by me or under my direct supervision and that I am a duly Registered Professional Engineer under the laws of the State of Wisconsin.

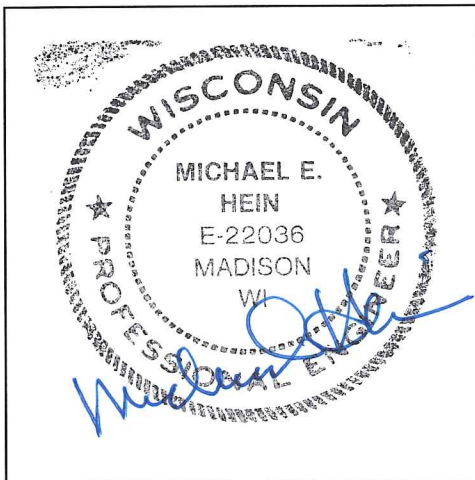

Michael Edward Hein - Registration No. 22036

Dated: February 4, 2016

SEALS PAGE

BID NO. 316001

**PROJECT: COLISEUM LOADING DOCKS ALLIANT ENERGY CENTER
ALLIANT ENERGY CENTER**

Page Intentionally Left Blank

TABLE OF CONTENTS FOR RFB NO. 316001

DIVISION 00 - PROCUREMENT AND CONTRACTING REQUIREMENTS

Project Manual Cover Page
Seals Pages
Table of Contents
Advertisement for Bids (Legal Notice)
Instructions to Bidders
Bid Form
Best Value Contracting Application
Fair Labor Practices Certification
Sample Public Works Contract
Sample Bid Bond
Sample Performance Bond
Sample Payment Bond
Equal Benefits Compliance Payment Certification
General Conditions of Contract
Supplementary Conditions (Including Prevailing Wage Determination)

DIVISION 01 - GENERAL REQUIREMENTS

01 00 00 - Basic Requirements
01 74 19 - Recycling

DIVISION 02 - EXISTING CONDITIONS

02 41 19 – Selective Demolition

DIVISION 03 - CONCRETE

03 300 00 – Cast-in-Place Concrete

DIVISION 05 - METALS

05 50 00 – Metal Fabrications

DIVISION 07 - THERMAL AND MOISTURE PROTECTION

07 11 13 – Bituminous Dampproofing
07 14 21 – Latex Mastic Deck Covering

DIVISION 08 - OPENINGS

08 11 13 – Hollow Metal Doors & Frames
08 36 14 – Hi-Speed Rolling Doors

DIVISION 09 - FINISHES

09 97 26 – Cementitious Coatings

DIVISION 11 - EQUIPMENT

11 13 00 – Loading Dock Equipment

DIVISION 22 - PLUMBING

22 00 00 - Plumbing

DIVISION 26 - ELECTRICAL

26 00 00 – Electrical

DIVISION 31 - EARTHWORK

31 20 00 – Earth Moving

DIVISION 32 – EXTERIOR IMPROVEMENTS

32 31 19 – Decorative Metal Fences and Gates

DRAWINGS

Plot drawings full size on 24" (ARCH C), 22" x 34

G0.1 – COVER SHEET

CIVIL

1 – TOPOGRAPHIC SURVEY & UTILITY MAP

C1.0 – SITE PLAN

C1.1 – SITE PAVING PLAN

STRUCTURAL

S001 – STRUCTURAL GENERAL NOTES

S002 – STRUCTURAL GENERAL NOTES

S101 – FOUNDATION PLAN

S201 – ROOF FRAMING PLAN

S301 – STRUCTURAL DETAILS

S302 – STRUCTURAL DETAILS

S303 – STRUCTURAL DETAILS

S304 – STRUCTURAL DETAILS

ARCHITECTURAL

A1.0 – FLOOR & ROOF PLAN

A2.0 – ELEVATIONS, SECTIONS & DETAILS

PLUMBING

P1.1 – FLOOR PLAN – PLUMBING

ELECTRICAL

E1.1 – FLOOR PLAN – ELECTRICAL

LEGAL NOTICE

INVITATION TO BID

Dane County Public Works, Highway & Transportation Dept., 1919 Alliant Energy Center Way, Madison, WI 53713, will receive sealed Bids until:

2:00 P.M., TUESDAY, FEBRUARY 23, 2016

REQUEST FOR BIDS NO. 316001

COLISEUM LOADING DOCKS ALLIANT ENERGY CENTER

1919 ALLIANT ENERGY CENTER WAY

MADISON, WISCONSIN

Dane County is inviting Bids for the construction of two new loading docks at the Veterans Memorial Coliseum on the Alliant Energy Center grounds. Only firms with capabilities, experience & expertise with similar projects should obtain this Request for Bids document & submit Bids.

Request for Bids document may be obtained **after 2:00 p.m. on Thursday, February 4, 2016** by downloading it from countyofdane.com/pwbids. Please call J. Eric Urtes, AIA -Project Manager, at 608/266-4798, or our office at 608/266-4018, for any questions or additional information.

All Bidders must be a registered vendor with Dane County & pay an annual registration fee & must be pre-qualified as a Best Value Contractor before award of Contract. Complete Vendor Registration Form at danepurchasing.com/registration or obtain one by calling 608/266-4131. Complete Pre-qualification Application for Contractors at countyofdane.com/pwht/BVC_Application.aspx or obtain one by calling 608/266-4029.

A pre-bid facility tour will be held Tuesday, February 9 at 1:00 p.m., starting at the Alliant Energy Center Administration Building. Bidders are strongly encouraged to attend this tour.

**PUBLISH: FEBRUARY 2 & FEBRUARY 9, 2016 - WISCONSIN STATE JOURNAL
FEBRUARY 2 & FEBRUARY 9, 2016 - THE DAILY REPORTER**

INSTRUCTIONS TO BIDDERS

TABLE OF CONTENTS

INSTRUCTIONS TO BIDDERS.....	1
1. GENERAL.....	1
2. DRAWINGS AND SPECIFICATIONS.....	2
3. INTERPRETATION.....	2
4. QUALIFICATIONS OF BIDDER (CONTRACTOR AND SUBCONTRACTOR)....	2
5. BID GUARANTEE.....	3
6. WITHDRAWAL OF BIDS.....	3
7. CONTRACT FORM.....	3
8. CONTRACT INTERESTS BY COUNTY PUBLIC OFFICIALS.....	3
9. EMERGING SMALL BUSINESS PROVISIONS.....	4
10. METHOD OF AWARD - RESERVATIONS.....	6
11. SECURITY FOR PERFORMANCE AND PAYMENTS.....	6
12. TAXES.....	6
13. SUBMISSION OF BIDS.....	6
14. SUBCONTRACTOR LISTING.....	7
15. ALTERNATE BIDS.....	7
16. ALLOWANCE.....	7
17. UNIT PRICES.....	7
18. COMMENCEMENT AND COMPLETION.....	8
19. WORK BY OWNER.....	8
20. SPECIAL HAZARDS COVERAGE.....	8
FORM A.....	9
FORM B.....	10
FORM C.....	11
FORM D.....	12

1. GENERAL

- A. Before submitting Bid, bidder shall thoroughly examine all Construction Documents. Successful Bidder shall be required to provide all the Work that is shown on Drawings, set forth in Specifications, or reasonably implied as necessary to complete Contract for this project.
- B. Bidder shall visit site to become acquainted with adjacent areas, means of approach to site, conditions of actual site and facilities for delivering, storing, placing, and handling of materials and equipment.
- C. Pre-bid meeting is scheduled on Tuesday, February 9 at 1:00 p.m. at the Alliant Energy Center Administration Building, 1919 Alliant Energy Center Way, Madison, WI.. Attendance by all bidders is optional, however bidders and subcontractors are strongly encouraged to attend.
- D. Failure to visit site or failure to examine any and all Construction Documents will in no way relieve successful Bidder from necessity of furnishing any necessary materials or equipment, or performing any work, that may be required to complete the Work in accordance with Drawings and Specifications. Neglect of above requirements will not be accepted as reason for delay in the Work or additional compensation.

2. DRAWINGS AND SPECIFICATIONS

- A. Drawings and Specifications that form part of this Contract, as stated in Article 1 of General Conditions of Contract, are enumerated in Document Index of these Construction Documents.
- B. Complete sets of Drawings and Specifications for all trades will be available to all Bidders, irrespective of category of work to be bid on, in order that all Bidders may be familiar with work of other trades as they affect their bid.

3. INTERPRETATION

- A. No verbal explanation or instructions will be given in regard to meaning of Drawings or Specifications before Bid Due Date. Bidders shall bring inadequacies, omissions or conflicts to Owner or Architect / Engineer's attention at least ten (10) calendar days before Bid Due Date. Prompt clarification will be available to all bidders by Addendum.
- B. Failure to so request clarification or interpretation of Drawings and Specifications will not relieve successful Bidder of responsibility. Signing of Contract will be considered as implicitly denoting that Contractor has thorough understanding of scope of the Work and comprehension of Construction Documents.
- C. Owner [or Architect / Engineer, Consultant / Engineer, Engineer] will not be responsible for verbal instructions.

4. QUALIFICATIONS OF BIDDER (CONTRACTOR AND SUBCONTRACTOR)

- A. Before award of Contract can be approved, Owner shall be satisfied that Bidder involved meets following requirements:
 - 1. Has completed at least one (1) project of at least fifty percent (50%) of size or value of Division of work being bid and type of work completed is similar to that being bid. If greater magnitude of experience is deemed necessary, other than size or value of work, such requirements will be described in appropriate section of Specifications.
 - 2. Maintains permanent place of business.
 - 3. Can be bonded for terms of proposed Contract.
 - 4. Has record of satisfactorily completing past projects and supplies list of no more than three (3) most recent, similar projects, with architect or engineer's and owner's names, addresses and telephone numbers for each project. Submit with Bid on Bid Date Criteria which will be considered in determining satisfactory completion of projects by bidder will include:
 - a. Completed contracts in accordance with drawings and specifications.
 - b. Diligently pursued execution of work and completed contracts according to established time schedule unless Owner grants extensions.
 - c. Fulfilled guarantee requirements of construction documents.
 - d. Is not presently on ineligible list maintained by County's Department of Administration for noncompliance with equal employment opportunities and affirmative action requirements.
 - e. Authorized to conduct business in Wisconsin. By submitting Bid, bidder warrants that it has: complied with all necessary requirements to do business in State of Wisconsin; that persons executing contract on its behalf are authorized to do so; and, if corporation, that name and address of bidder's registered agent are as set forth in

Contract. Bidder shall notify Owner immediately, in writing, of any change in its registered agent, their address, and bidder's legal status. For partnership, term "registered agent" shall mean general partner.

- B. County's Public Works Project Engineer will make such investigations as are deemed necessary to determine ability of bidder to perform the Work, and bidder shall furnish to County's Public Works Project Engineer or designee all such information and data for this purpose as County's Public Works Project Engineer may request. Owner reserves right to reject Bid if evidence submitted by, or investigation of, bidder fails to satisfy Owner that bidder is responsible and qualified to carry out obligations of Contract and to complete the Work contemplated therein.

5. BID GUARANTEE

- A. Bank certified check, cashier's check or Bid Bond, payable to County in amount not less than five percent (5%) of maximum bid, shall accompany each Bid as guarantee that if Bid is accepted, Bidder will execute and return proposed Contract and Performance and Payment Bonds within ten (10) business days after being notified of acceptance of Bid. Company issuing bonds must be licensed to do business in Wisconsin.
- B. Any bid, which is not accompanied by bid guarantee, will be considered "No Bid" and will not be read at Bid Due Date.
- C. If successful Bidder so delivers Contract, Certificate of Insurance, and Performance and Payment Bonds, check will be returned to Bidder. In case Bidder fails to deliver such Contract, insurance, and bond, amount of bid guarantee will be forfeited to County as liquidated damages.
- D. All checks tendered as bid guarantee, except those of three (3) lowest qualified, responsible bidders, will be returned to their makers within three (3) business days after Bid Due Date. All such retained checks will be returned immediately upon signing of Contract and Performance and Payment Bonds by successful Bidder.

6. WITHDRAWAL OF BIDS

- A. Bids may be withdrawn by written request received from bidder or authorized representative thereof prior to time fixed for Bid Due Date, without prejudice to right of bidder to file new Bid. Withdrawn Bids will be returned unopened. Negligence on part of bidder in preparing their Bid confers no right for withdrawal of Bid after it has been opened.
- B. No Bid may be withdrawn for period of sixty (60) calendar days after Bid Due Date.
- C. If Bid contains error, omission or mistake, bidder may limit liability to amount of bidder's guarantee by giving written Notice of Intent not to execute Contract to Owner within seventy-two (72) hours of Bid Due Date.

7. CONTRACT FORM

- A. Sample copy of contract that successful Bidder will be required to enter into is included in these Construction Documents and bidders are required to familiarize themselves with all conditions contained therein.

8. CONTRACT INTERESTS BY COUNTY PUBLIC OFFICIALS

- A. In accordance with Wisconsin Statute 946.13, county official may not bid for or enter into any contract involving receipts or disbursements of more than \$15,000.00 in a year, in which they have private pecuniary interest, direct or indirect if at same time they are authorized to take official action with respect to making of this Contract. Any contract entered into in violation of this Statute is void and County incurs no liability thereon. This subsection does not affect application and enforcement of Wisconsin Statute 946.13 by state prosecutors in criminal courts of this state.

9. EMERGING SMALL BUSINESS PROVISIONS

- A. **Emerging Small Business Definition.** For purposes of this provision, ESB is defined as:
1. Independent business concern that has been in business minimum of one year;
 2. Business located in State of Wisconsin;
 3. Business comprised of less than twenty-five (25) employees;
 4. Business must not have gross sales in excess of three million dollars (\$3,000,000.00) over past three years; and
 5. Business does not have history of failing to complete projects.
- B. **Emerging Small Business (ESB) Involvement.** Bidder shall make good faith effort to award minimum of ten percent (10%) of the Work to ESBs. Bidder shall submit report to Dane County Contract Compliance Officer within ten (10) days after Bid Due Date demonstrating such efforts. Good faith efforts means significant contact with ESBs for purposes of soliciting bids from them. Failure to make or demonstrate good faith efforts will be grounds for disqualification.
- C. **Emerging Small Business Report.** Emerging Small Business Enterprise Report is to be submitted by Bidder in separate envelope marked "Emerging Small Business Report". This report is due by 2:00 p.m. following specified ten (10) days after Bid Due Date. Bidder who fails to submit Emerging Small Business Report shall be deemed not responsive.
- D. **ESB Goal.** Goal of this project is ten percent (10%) ESB participation. ESB utilizations are shown as percentage of total Bid. If Bidder meets or exceeds specified goal, Bidder is only required to submit Form A - Certification, and Form B - Involvement. Goal shall be met if Bidder qualifies as ESB.
- E. **Report Contents.** Following award of Contract, Bidder shall submit copies of executed contracts for all Emerging Small Businesses. Emerging Small Business Report shall consist of these:
1. Form A - Certification;
 2. Form B - Involvement;
 3. Form C - Contacts;
 4. Form D - Certification Statement (if appropriate); and
 5. Supportive documentation (i.e., copies of correspondence, telephone logs, copies of advertisements).
- F. **ESB Listing.** Bidders will solicit bids from ESB listing provided by Dane County.

- G. **ESB Certification.** All contractors, subcontractors and suppliers seeking ESB certification must complete and submit Emerging Small Business Certification Application to Dane County Contract Compliance Program.
- H. **Certification Statement.** If ESB firm has not been certified by County as ESB prior to submittal of this Bid, ESB Report cannot be used to fulfill ESB goal for this project unless firm provides "Form D - Certification Statement". Certification statement must be completed and signed by ESB firm.
- I. **Questions.** Questions concerning Emerging Small Business provisions shall be directed to:
- Dane County Contract Compliance Officer
City-County Building, Room 421
210 Martin Luther King, Jr. Blvd.
Madison, WI 53703
608/266-5623
- J. **Substituting ESBs.** In event of any significant changes in subcontract arrangements or if need arises to substitute ESBs, Bidder shall report such proposed changes to Contract Compliance Officer to making any official changes and request authorization to substitute ESB firm. Bidder further agrees to make every possible effort to replace ESB firm with another qualified ESB firm.
- K. **Good Faith Efforts.** Good faith efforts can be demonstrated by meeting all of these obligations:
1. Selecting portions of the Work to be performed by ESBs in order to increase likelihood of meeting ESB goal including, where appropriate, breaking down Contract into smaller units to facilitate ESB participation.
 2. Advertising in general circulation, trade associations and women / minority focus media concerning subcontracting opportunities.
 3. Providing written notices to reasonable number of specific ESBs that their interest in Contract was being solicited in sufficient time to allow ESBs to participate effectively.
 4. Following up on initial solicitations of interest by contacting ESBs within five (5) business days prior to Bid Due Date to determine with certainty whether ESB were interested, to allow ESBs to prepare bids.
 5. Providing interested ESB with adequate information about Drawings, Specifications and requirements of Contract.
 6. Using services of available minority, women and small business organizations and other organizations that provide assistance in recruitment of MBEs / WBEs / ESBs.
 7. Negotiating in good faith with interested ESBs, not rejecting ESBs as unqualified without sound reason based on thorough investigation of their capabilities.
 8. Submitting required project reports and accompanying documents to County's Contract Compliance Officer within twenty-four (24) hours after Bid Due Date.
- L. **Appeals Disqualification of Bid.** Bidder who is disqualified may appeal to Public Works & Transportation Committee and Equal Opportunity Commission.

10. METHOD OF AWARD - RESERVATIONS

- A. Following will be basis of award of Contract, providing cost does not exceed amount of funds then estimated by County as available to finance Contract(s):
 - 1. Lowest dollar amount submitted by qualified responsible bidder on Base Bid for all work comprising project, combined with such additive Owner accepted alternates.
 - 2. Owner reserves right to reject all bids or any bid, to waive any informality in any bid, and to accept any bid that will best serve interests of County.
 - 3. Unit Prices and Informational Bids will not be considered in establishing low bidder.

11. SECURITY FOR PERFORMANCE AND PAYMENTS

- A. Simultaneous with delivery of signed Contract, Bidder shall be required to furnish Performance and Payment Bonds as specified in Article 29 of General Conditions of Contract. Surety Company shall be licensed to do business in Wisconsin. Performance and Payment Bonds must be dated same date or subsequent to date of Contract. Performance and Payment Bonds must emulate information in Sample Performance and Payment Bonds in Construction Documents.
- B. Provide certified copy of power of attorney from Surety Company showing that agent who signs Bond has power of attorney to sign for Surety Company. Secretary or Assistant Secretary of company must sign this certification, not attorney-in-fact. Certification must bear same or later date as Bond. Power of Attorney must emulate model power of attorney information detailed in Sample Performance and Payment Bonds.
- C. If Bidder is partnership or joint venture, State certified list, providing names of individuals constituting partnership or joint venture must be furnished. Contract itself may be signed by one partner of partnership, or one partner of each firm comprising joint venture, but Performance and Payment Bonds must be signed by all partners.
- D. If Bidder is a corporation, it is necessary that current certified copy of resolution or other official act of directors of corporation be submitted showing that person who signs Contract is authorized to sign contracts for corporation. It is also necessary that corporate seal be affixed to resolution, contract, and performance and payment bonds. If your corporation has no seal, it is required that above documents include statement or notation to effect that corporation has no seal.

12. TAXES

- A. Bidder shall include in Bid, all Sales, Consumer, Use and other similar taxes required by law.
- B. In accordance with Wisconsin Statute 71.80(16)(a), successful nonresident bidder, whether incorporated or not, and not otherwise regularly engaged in business in this state, shall file surety bond with State of Wisconsin Department of Revenue payable to Department of Revenue, to guarantee payment of income taxes, required unemployment compensation contributions, sales and use taxes and income taxes withheld from wages of employees, together with any penalties and interest thereon. Amount of bond shall be three percent (3%) of Contract or subcontract price on all contracts of \$50,000 or more.

13. SUBMISSION OF BIDS

- A. All Bids shall be submitted on standard Bid Form bound herein and only Bids that are made on this Bid Form will be considered. Entire Bid Form and other supporting documents, if any, shall be removed or copied from Construction Documents, filled out, and submitted in manner specified hereinafter. Submit completed Bid Bond with Bid as well.
- B. No bids for any subdivision or any sub-classification of this Work, except as indicated, will be accepted. Any conditional Bid, amendment to Bid Form or appended item thereto, or inclusion of any correspondence, written or printed matter, or details of any nature other than that specifically called for, which would alter any essential provision of Construction Documents, or require consideration of unsolicited material or data in determining award of Contract, will disqualify Bid. Telecommunication alterations to Bid will not be accepted.
- C. Bidders must submit single Bid for all the Work.
- D. Bid amounts shall be inserted in words and in figures in spaces provided on Bid Form; in case of conflict, written word amounts will govern.
- E. Addenda issued after Bid Letting shall become part of Construction Documents. Bidders shall acknowledge receipt of such addenda in appropriate space provided on Bid Form. Bid may be rejected if receipt of any particular addendum applicable to award of Contract has not been acknowledged on Bid Form.
- F. Bids shall be signed, placed in envelope, sealed and delivered before due time to place designated in Invitation to Bid, and identified with project name, bid number, location, category of work being bid upon, Bid Due Date, name and address of bidder.
- G. Bidder shall be responsible for sealed Bid being delivered to place designated for Bid Due Date on or before date and time specified. Bids received after time of closing will be rejected and returned to bidder unopened.
- H. Bid will be considered invalid and will be rejected if bidder has not signed it.
- I. Faxed or emailed Bids will not be accepted.
- J. Bidder's organization shall submit completed with Bid, Fair Labor Practices Certification form, included in these Construction Documents.

14. SUBCONTRACTOR LISTING

- A. Bidders shall be required to submit list of major subcontractors for General Construction, Plumbing, HVAC, and Electrical work proposed for this project to include committed prices for each subcontractor. List shall be placed in separate sealed envelope that must be clearly identified as "Major Subcontractor List", for named project and name of Bidder submitting it. County must receive envelope no later than date by which successful Bidder is required to submit his or her signed Contract, as established in Construction Documents.

15. ALTERNATE BIDS

- A. Not Applicable

16. ALLOWANCE

- A. Not Used.

17. UNIT PRICES

- A. Provide unit prices where requested on Bid Form. Unit prices will include all costs for materials, labor, insurance, taxes, overhead and profit necessary to perform specified work. Estimated quantities are approximate only. Payment will be based upon actual quantities placed, provided or installed. Failure to provide requested unit prices may result in rejection of entire Bid.
- B. Owner reserves right to accept or reject any unit prices as given in Bid.
- C. Bidder shall refer to Bid Form and applicable specification section to determine basis of unit measure and detailed information related to each unit price item requested.

18. COMMENCEMENT AND COMPLETION

- A. Successful Bidder shall commence work when schedule and weather permit, but no later than stated in Bid Form. Contractor shall pursue the Work regularly and continuously at reasonable rate to insure completion of the Work within time stated in Bid.
- B. Should it be found impossible to complete the Work on or before time specified for completion, written request may be submitted for extension of time setting forth reasons believed to justify granting of such request. Refer to [Article 20 of General Conditions of Contract, titled "Time for Completion".

19. WORK BY OWNER

- A. Not Applicable.

20. SPECIAL HAZARDS COVERAGE

- A. Not Applicable.

FORM A

**DANE COUNTY
EMERGING SMALL BUSINESS REPORT - CERTIFICATION**

In accordance with General Conditions of Contract, submit this Emerging Small Business Report within ten (10) days after Bid Due Date.

PROJECT NAME: _____

BID NO.: _____ BID DUE DATE: _____

BIDDER INFORMATION

COMPANY NAME: _____

ADDRESS: _____

TELEPHONE NO.: _____

CONTACT PERSON: _____

EMAIL ADDRESS: _____

FORM B

Page ___ of ___

DANE COUNTY

(Copy this Form as necessary to provide complete information)

EMERGING SMALL BUSINESS REPORT - INVOLVEMENT

COMPANY NAME: _____

PROJECT NAME: _____

BID NO.: _____ BID DUE DATE: _____

ESB NAME: _____

CONTACT PERSON: _____

ADDRESS: _____

PHONE NO & EMAIL.: _____

Indicate percentage of financial commitment to this ESB: _____ % Amount: \$ _____

ESB NAME: _____

CONTACT PERSON: _____

ADDRESS: _____

PHONE NO & EMAIL.: _____

Indicate percentage of financial commitment to this ESB: _____ % Amount: \$ _____

FORM C

Page ___ of ___

**DANE COUNTY
EMERGING SMALL BUSINESS REPORT - CONTACTS**

(Copy this Form as necessary to provide complete information)

COMPANY NAME: _____

PROJECT NAME: _____

BID NO.: _____ BID DUE DATE: _____

	<u>ESB FIRM NAME CONTACTED</u>	<u>DATE</u>	<u>PERSON CONTACTED</u>	<u>DID ESB BID?</u>	<u>ACC- EPT BID?</u>	<u>REASON FOR REJECTION</u>
1)	_____	_____	_____	_____	_____	_____
2)	_____	_____	_____	_____	_____	_____
3)	_____	_____	_____	_____	_____	_____
4)	_____	_____	_____	_____	_____	_____
5)	_____	_____	_____	_____	_____	_____
6)	_____	_____	_____	_____	_____	_____
7)	_____	_____	_____	_____	_____	_____
8)	_____	_____	_____	_____	_____	_____

FORM D

**DANE COUNTY
EMERGING SMALL BUSINESS REPORT - CERTIFICATION STATEMENT**

I, _____, _____ of
Name Title

_____ certify to best of my knowledge and
Company

belief that this business meets Emerging Small Business definition as indicated in Article 9 and
that information contained in this Emerging Small Business Report is true and correct.

Bidder's Signature

Date

Name of Bidding Firm: _____

BID FORM

BID NO. 316001

**PROJECT: COLISEUM LOADING DOCKS
ALLIANT ENERGY CENTER
1919 ALLIANT ENERGY CENTER WAY – MADISON, WISCONSIN**

**TO: DANE COUNTY DEPARTMENT OF PUBLIC WORKS, HIGHWAY &
TRANSPORTATION - PROJECT MANAGER
1919 ALLIANT ENERGY CENTER WAY
MADISON, WISCONSIN 53713**

BASE BID - LUMP SUM:

Dane County is inviting Bids for the construction of two new loading docks and a canopy which are to be located adjacent to the north side of the Veterans Memorial Coliseum on the Alliant Energy Center grounds. Only firms with capabilities, experience & expertise with similar projects should obtain this Request for Bids document & submit Bids. The undersigned, having examined the site where the Work is to be executed and having become familiar with local conditions affecting the cost of the Work and having carefully examined the Drawings and Specifications, all other Construction Documents and Addenda thereto prepared by Dane County Department of Public Works, Highway & Transportation hereby agrees to provide all labor, materials, equipment and services necessary for the complete and satisfactory execution of the entire Work, as specified in the Construction Documents, for the Base Bid stipulated sum of:

_____ and _____ /100 Dollars
Written Price

\$ _____
Numeric Price

UNIT PRICING: REMOVAL OF SOIL

Add price for the removal of unsuitable soil and engineered fill material where soil testing agency has determined existing conditions are insufficient for the purposes of the project (as defined by the Specifications).

Unsuitable Soil Removal & Replacement with Engineered Fill:

- 500 cu. yds or less: @ \$ _____/cu. yd.

_____ and _____ /100 Dollars
Written Price

- 500 cu. yds or greater: @ \$ _____/cu. yd.

_____ and _____ /100 Dollars
Written Price

UNIT PRICING: PAVING

Add price for the adjustment of paving in the project defined areas (as defined by the Specifications).

Asphalt Paving:

- 500 cu. yds or less: @ \$ _____/cu. yd.

_____ and _____ /100 Dollars
 Written Price

- 500 cu. yds or greater: @ \$ _____/cu. yd.

_____ and _____ /100 Dollars
 Written Price

Receipt of the following addenda and inclusion of their provisions in this Bid is hereby acknowledged:

Addendum No(s). _____ through _____

Dated _____

Dane County Alliant Energy Center must have this project completed by July 31, 2016. Assuming this Work can be authorized to proceed by March 29, 2016 (with Work on-site to begin on April 25, 2016) what dates can you commence and complete this job?

Commencement Date: _____ Completion Date: _____
(final, not substantial)

I hereby certify that all statements herein are made on behalf of:

(Name of Corporation, Partnership or Person submitting Bid)

Select one of the following:

1. A corporation organized and existing under the laws of the State of _____, or
2. A partnership consisting of _____, or
3. A person conducting business as _____;

Of the City, Village, or Town of _____ of the State of _____.

I have examined and carefully prepared this Bid from the associated Construction Documents and have checked the same in detail before submitting this Bid; that I have full authority to make such statements and submit this Bid in (its) (their) (my) behalf; and that the said statements are true and correct. In signing this Bid, we also certify that we have not, either directly or indirectly, entered into any agreement or participated in any collusion or otherwise taken any action in restraint of free competition; that no attempt has been made to induce any other person or firm to submit or not to submit a Bid; that this Bid has been independently arrived at without collusion

with any other bidder, competitor, or potential competitor; that this Bid has not been knowingly disclosed prior to the Bids Due Date to another bidder or competitor; that the above statement is accurate under penalty of perjury.

The undersigned further agrees to honor the Base Bid and the Alternate Bid(s) for sixty (60) days from date of Award of Contract.

SIGNATURE: _____
(Bid is invalid without signature)

Print Name: _____ Date: _____

Title: _____

Address: _____

Telephone No.: _____ Fax No.: _____

Email Address: _____

Contact Person: _____

THIS PAGE IS FOR BIDDERS' REFERENCE AND NEED NOT BE SUBMITTED WITH BID FORM.

BID CHECK LIST:

These items **must** be included with Bid:

- Bid Form Bid Bond Fair Labor Practices Certification
 Project Experience / Reference Summary (See ITB - 4. Qualifications of Bidder)

BIDDERS SHOULD BE AWARE OF THE FOLLOWING:

DANE COUNTY VENDOR REGISTRATION PROGRAM

Any person bidding on any County contract must be registered with the Dane County Purchasing Division & pay an annual registration fee. A contract will not be awarded to an unregistered vendor. Obtain a *Vendor Registration Form* by calling 608/266-4131 or complete a new form or renewal online at:

www.danepurchasing.com/registration

DANE COUNTY BEST VALUE CONTRACTING PRE-QUALIFICATION

Contractors must be pre-qualified as a Best Value Contractor with the Dane County Public Works Engineering Division before the award of contract. Obtain a *Best Value Contracting Application* by calling 608/266-4018 or complete one online at:

www.countyofdane.com/pwht/BVC_Application.aspx

EQUAL BENEFITS REQUIREMENT

By submitting a Bid, the contractor acknowledges that a condition of this contract is to provide equal benefits as required by Dane County Code of Ordinances Chapter 25.016. Contractor shall provide equal benefits as required by that Ordinance to all required employees during the term of the contract. Equal Benefits Compliance Payment Certification shall be submitted with final pay request. For more information:

www.danepurchasing.com/partner_benefit.aspx



DANE COUNTY DEPARTMENT of PUBLIC WORKS, HIGHWAY and TRANSPORTATION

County Executive
Joseph T. Parisi

1919 Alliant Energy Center Way ♦ Madison, Wisconsin 53713
Phone: (608) 266-4018 ♦ FAX: (608) 267-1533

Commissioner / Director
Gerald J. Mandli

BEST VALUE CONTRACTING APPLICATION

CONTRACTORS / LICENSURE APPLICANTS

The Dane County Department of Public Works requires all contractors to be pre-qualified as a best value contractor with the County prior to being awarded a contract. In addition, the County pre-qualifies potential contractors and sub-contractors who wish to work on County contracts. Subcontractors must become pre-qualified ten (10) days prior to commencing work under any Dane County Public Works Contract. Potential subcontractors are urged to become pre-qualified as early as possible. This document shall be completed, properly executed, along with the necessary attachments and additional information that the County requires for the protection and welfare of the public in the performance of a County contract.

Contractors or subcontractors of any tier who attain pre-qualification status will retain that status for a period of two (2) years from the date of qualification. Contractors shall notify the Dane County Department of Public Works, Highway & Transportation within fifteen (15) days of any changes to its business or operations that are relevant to the pre-qualification application. Failure to do so could result in suspension, revocation of the contractor's pre-qualification, debarment from County contracts for up to three (3) years and / or other sanctions available under the law.

No contracts will be awarded for construction work performed on Dane County projects unless the contractor is currently approved as a Wisconsin Trade Trainer or has applied for approval as an Apprenticeship Trade Trainer to the Wisconsin Department of Workforce Development and agrees to an acceptable apprenticeship program. If you are not currently approved as a Wisconsin Trade Trainer, or have not applied for approval as an Apprenticeship Trade Trainer, please contact the Department of Workforce Development - Bureau of Apprenticeship Standards at 608/266-3133 or visit their web site at: dwd.wisconsin.gov/apprenticeship/.

EXEMPTIONS

- Contractors who employ less than five (5) apprenticeable trade workers are not required to pre-qualify.
- Contractors performing work that does not apply to an apprenticeable trade, as outlined in Appendix A.
- The contractor / subcontractor provides sufficient documentation to demonstrate one or more of the following:
 - apprentices are not available in a specific geographic area;
 - the applicable apprenticeship program is unsuitable or unavailable; or
 - there is a documented depression of the local construction market which prevents compliance.

SEC.	PROOF OF RESPONSIBILITY	CHECK IF APPLICABLE
1	Does your firm possess all technical qualifications and resources, including equipment, personnel and financial resources, necessary to perform the work required for any project or obtain the same through the use of responsible, pre-qualified subcontractors?	Yes: <input type="checkbox"/> No: <input type="checkbox"/>
2	Will your firm possess all valid, effective licenses, registrations or certificates required by federal, state, county, or local law, which are necessary for the type of work to be performed including, but not limited to, those for any type of trade work or specialty work?	Yes: <input type="checkbox"/> No: <input type="checkbox"/>
3	Will your firm meet all bonding requirements as required by applicable law or contract specifications?	Yes: <input type="checkbox"/> No: <input type="checkbox"/>
4	Will your firm meet all insurance requirements as required by applicable law or specifications, including general liability insurance, workers compensation insurance and unemployment insurance requirements?	Yes: <input type="checkbox"/> No: <input type="checkbox"/>
5	Will your firm maintain a substance abuse policy for employees hired for public works contracts that comply with Wis. Stats. Sec. 103.503?	Yes: <input type="checkbox"/> No: <input type="checkbox"/>
6	Does your firm acknowledge that it must pay all craft employees on public works projects the wage rates and benefits required under Section 66.0903 of the Wisconsin Statutes?	Yes: <input type="checkbox"/> No: <input type="checkbox"/>
7	Will your firm fully abide by the equal opportunity and affirmative action requirements of all applicable laws, including County ordinances?	Yes: <input type="checkbox"/> No: <input type="checkbox"/>
8	In the past three (3) years, has your firm had control or has another corporation, partnership or other business entity operating in the construction industry controlled it? If so, please attach a statement explaining the nature of the firm relationship?	Yes: <input type="checkbox"/> No: <input type="checkbox"/> If Yes, attach details.
9	In the past three (3) years, has your firm had any type of business, contracting or trade license, certification or registration revoked or suspended?	Yes: <input type="checkbox"/> No: <input type="checkbox"/> If Yes, attach details.
10	In the past three (3) years, has your firm been debarred by any federal, state or local government agency?	Yes: <input type="checkbox"/> No: <input type="checkbox"/> If Yes, attach details.
11	In the past three (3) years, has your firm defaulted or failed to complete any contract?	Yes: <input type="checkbox"/> No: <input type="checkbox"/> If Yes, attach details.
12	In the past three (3) years, has your firm committed a willful violation of federal, state or local government safety laws as determined by a final decision of a court or government agency authority.	Yes: <input type="checkbox"/> No: <input type="checkbox"/> If Yes, attach details.
13	In the past three (3) years, has your firm been in violation of any law relating to your contracting business where the penalty for such violation resulted in the imposition of a penalty greater than \$10,000?	Yes: <input type="checkbox"/> No: <input type="checkbox"/> If Yes, attach details.
14	Is your firm Executive Order 108 precertified with the State of Wisconsin?	Yes: <input type="checkbox"/> No: <input type="checkbox"/>
15	Is your firm an active Wisconsin Trade Trainer as determined by the Wisconsin Bureau of Apprenticeship Standards?	Yes: <input type="checkbox"/> No: <input type="checkbox"/>
16	Is your firm exempt from being pre-qualified with Dane County?	Yes: <input type="checkbox"/> No: <input type="checkbox"/> If Yes, attach reason for exemption.
17	Does your firm acknowledge that in doing work under any County Public Works Contract, it will be required to use as subcontractors only those contractors that are also pre-qualified with the County or become so ten days prior to commencing work?	Yes: <input type="checkbox"/> No: <input type="checkbox"/>
18	Contractor has been in business less than one year?	Yes: <input type="checkbox"/> No: <input type="checkbox"/>
19	Is your firm a first time Contractor requesting a one time exemption, but, intend to comply on all future contracts and are taking steps typical of a "good faith" effort?	Yes: <input type="checkbox"/> No: <input type="checkbox"/>
20	Not applicable. My firm does not intend to work on Best Value Contracts. Note: Best Value Contracting is required to bid on most Public Works Contracts (if unclear, please call Jan Neitzel Knox 608-266-4029).	Yes: <input type="checkbox"/> No: <input type="checkbox"/>

SIGNATURE SECTION

Your firm's Officer, or the individual who would sign a bid and / or contract documents must sign this document.

I do hereby certify that all statements herein contained are true and correct to the best of my knowledge:

Signature

Date

Printed or Typed Name and Title

NAME AND ADDRESS OF CONTRACTOR	
Name of Firm:	
Address:	
City, State, Zip:	
Telephone Number:	
Fax Number:	
E-mail Address:	

REMEMBER!

Return all to forms and attachments, or questions to:

JAN NEITZEL KNOX
EMAIL: NEITZEL-KNOX@COUNTYOFDANE.COM
OFFICE: (608)266-4029, FAX: (608)267-1533

**DANE COUNTY DEPARTMENT OF PUBLIC WORKS,
HIGHWAY & TRANSPORTATION
1919 ALLIANT ENERGY CENTER WAY
MADISON, WI 53713**

APPENDIX A

APPRENTICEABLE TRADES

Bricklayer
Carpenter
Cement Mason (Concrete Finisher)
Cement Mason (Heavy Highway)
Construction Craft Laborer
Data Communications Installer
Electrician
Elevator Mechanic / Technician
Environmental Systems Technician / HVAC Service Technician / HVAC Install & Service
Glazier
Heavy Equipment Operator / Operating Engineer
Insulation Worker (Heat & Frost)
Iron Worker (Assembler, Metal Buildings)
Painter / Decorator
Plasterer
Plumber
Roofer / Waterproofer
Sheet Metal Worker
Sprinkler Fitter
Steamfitter (Service & Refrigeration)
Taper & Finisher
Telecommunications (Voice, Data & Video) Installer / Technician
Tile Setter

FAIR LABOR PRACTICES CERTIFICATION

The undersigned, for and on behalf of the BIDDER, APPLICANT or PROPOSER named herein, certifies as follows:

- A. That he or she is an officer or duly authorized agent of the above-referenced BIDDER, APPLICANT or PROPOSER, which has submitted a bid, application or proposal for a contract or agreement with the county of Dane.

- B. That BIDDER, APPLICANT or PROPOSER has (check one):

_____ not been found by the National Labor Relations Board (“NLRB”) or the Wisconsin Employment Relations Commission (“WERC”) to have violated any statute or regulation regarding labor standards or relations in the seven years prior to the signature date of this Certification.

_____ been found by the National Labor Relations Board (“NLRB”) or the Wisconsin Employment Relations Commission (“WERC”) to have violated any statute or regulation regarding labor standards or relations in the seven years prior to the signature date of this Certification.

Officer or Authorized Agent Signature

Date

Printed or Typed Name and Title

Printed or Typed Business Name

NOTE: You can find information regarding the violations described above at: www.nlrb.gov and werc.wi.gov.

For reference, Dane County Ordinance 25.11(28)(a) is as follows:

(28) BIDDER RESPONSIBILITY. (a) Any bid, application or proposal for any contract with the county, including public works contracts regulated under chapter 40, shall include a certification indicating whether the bidder has been found by the National Labor Relations Board (NLRB) or the Wisconsin Employment Relations Committee (WERC) to have violated any statute or regulation regarding labor standards or relations within the last seven years. The purchasing manager shall investigate any such finding and make a recommendation to the committee, which shall determine whether the conduct resulting in the finding affects the bidder’s responsibility to perform the contract.

If you indicated that the NLRB or WERC have found you to have such a violation, you must include copies of any relevant information regarding such violation with your proposal, bid or application.

Include this completed Certification with your bid, application or proposal.

COUNTY OF DANE

PUBLIC WORKS CONSTRUCTION CONTRACT

Contract No. _____ Bid No. 316001

Authority: 2015 RES - _____

THIS CONTRACT, made and entered into as of the date by which authorized representatives of both parties have affixed their signatures, by and between the County of Dane (hereafter referred to as "COUNTY") and _____ (hereafter, "CONTRACTOR"), and

WITNESSETH:

WHEREAS, COUNTY, whose address is c/o Assistant Public Works Director, 1919 Alliant Energy Center Way, Madison, WI 53713, desires to have CONTRACTOR provide the Coliseum Loading Docks at the Alliant Energy Center ("the Project"); and

WHEREAS, CONTRACTOR, whose address is _____ is able and willing to construct the Project, in accordance with the Construction Documents;

NOW, THEREFORE, in consideration of the above premises and the mutual covenants of the parties hereinafter set forth, the receipt and sufficiency of which is acknowledged by each party for itself, COUNTY and CONTRACTOR do agree as follows:

1. CONTRACTOR agrees to construct, for the price of \$ _____ the Project and at the CONTRACTOR'S own proper cost and expense to furnish all materials, supplies, machinery, equipment, tools, superintendence labor, insurance, and other accessories and services necessary to complete the Project in accordance with the conditions and prices stated in the Bid Form, General Conditions of Contract, the drawings which include all maps, plats, plans, and other drawings and printed or written explanatory matter thereof, and the specifications therefore as prepared by Dimension IV - Madison Design Group (hereinafter referred to as "the Architect / Engineer"), and as enumerated in the Project Manual Table of Contents, all of which are made a part hereof and collectively evidence and constitute the Contract.

2. COUNTY agrees to pay the CONTRACTOR in current funds for the performance of the Contract subject to additions and deductions, as provided in the General Conditions of Contract, and to make payments on account thereof as provided in Article entitled, "Payments to Contractor" of the General Conditions of Contract.

3. During the term of this Contract, CONTRACTOR agrees to take affirmative action to ensure equal employment opportunities. The CONTRACTOR agrees in accordance with Wisconsin Statute 111.321 and Chapter 19 of the Dane County Code of Ordinances not to discriminate on the basis of age, race, ethnicity, religion, color, gender, disability, marital status, sexual orientation, national origin, cultural differences, ancestry, physical appearance, arrest record or conviction record, military participation or membership in the national guard, state defense force or any other reserve component of the military forces of the United States, or political beliefs.

Such equal opportunity shall include, but not be limited to, the following: employment, upgrading, demotion, transfer, recruitment, advertising, layoff, termination, training, rates of pay, and any other form of compensation. CONTRACTOR agrees to post in conspicuous places, available to all employees and applicants for employment, notices setting forth the provisions of this paragraph.

4. CONTRACTOR shall file an Affirmative Action Plan with the Dane County Contract Compliance Officer in accord with Chapter 19 of the Dane County Code of Ordinances. CONTRACTOR must file such plan within fifteen (15) business days of the effective date of this Contract. During the term of this Contract CONTRACTOR shall also provide copies of all announcements of employment opportunities to COUNTY'S Contract Compliance Office, and shall report annually the number of persons, by race, ethnicity, gender, and disability status, which apply for employment and, similarly classified, the number hired and number rejected.

5. During the term of this Contract, all solicitations for employment placed on CONTRACTOR'S behalf shall include a statement to the effect that CONTRACTOR is an "Equal Opportunity Employer".

6. CONTRACTOR agrees to comply with provisions of Chapter 25.016 of the Dane County Code of Ordinances, which pertains to domestic partnership benefits.

7. CONTRACTOR agrees to furnish all information and reports required by COUNTY'S Contract Compliance Officer as the same relate to affirmative action and nondiscrimination, which may include any books, records, or accounts deemed appropriate to determine compliance with Chapter 19, Dane County Code of Ordinances, and the provisions of this Contract.

8. CONTRACTOR agrees that all persons employed by CONTRACTOR or any subcontractor shall be paid no less than the minimum wage established under Chapter 40, Subchapter II, Dane County Code of Ordinances. CONTRACTOR agrees to abide by and comply with the provisions of Chapter 40, Subchapter II of the Dane County Code of Ordinances, and said Subchapter is fully incorporated herein by reference.

9. This Contract is intended to be a Contract solely between the parties hereto and for their benefit only. No part of this Contract shall be construed to add to, supplement, amend, abridge or repeal existing rights, benefits or privileges of any third party or parties including, but not limited to, employees of either of the parties.

10. The entire agreement of the parties is contained herein and this Contract supersedes any and all oral agreements and negotiations between the parties relating to the subject matter hereof. The parties expressly agree that the express terms of this Contract shall not be amended in any fashion except in writing, executed by both parties.

11. CONTRACTOR must be pre-qualified as a Best Value Contractor with Dane County Public Works Engineering Division before award of Contract. Subcontractors must be pre-qualified ten (10) business days prior to commencing Work under this Contract.

12. Attachment A is the Contractor's quote and is made a part of this Contract.

IN WITNESS WHEREOF, COUNTY and CONTRACTOR, by their respective authorized agents, have caused this Contract and its Schedules to be executed, effective as of the date by which all parties hereto have affixed their respective signatures, as indicated below.

* * * * *

FOR CONTRACTOR:

Signature Date

Printed or Typed Name and Title

Signature Date

Printed or Typed Name and Title

NOTE: If CONTRACTOR is a corporation, Secretary should attest. In accordance with IRS Regulations, unincorporated entities are required to provide either their Social Security or Employer Number in order to receive payment for services rendered.

* * * * *

This Contract is not valid or effectual for any purpose until approved by the appropriate authority designated below, and no work is authorized until the CONTRACTOR has been given notice to proceed by COUNTY'S Assistant Public Works Director.

FOR COUNTY:

Joseph T. Parisi, County Executive Date

Scott McDonell, County Clerk Date

AIA[®] Document A310[™] – 2010

Bid Bond

CONTRACTOR:

(Name, legal status and address)

SURETY:

(Name, legal status and principal place of business)

OWNER:

(Name, legal status and address)

BOND AMOUNT:**PROJECT:**

(Name, location or address, and Project number, if any)

This document has important legal consequences. Consultation with an attorney is encouraged with respect to its completion or modification.

Any singular reference to Contractor, Surety, Owner or other party shall be considered plural where applicable.

The Contractor and Surety are bound to the Owner in the amount set forth above, for the payment of which the Contractor and Surety bind themselves, their heirs, executors, administrators, successors and assigns, jointly and severally, as provided herein. The conditions of this Bond are such that if the Owner accepts the bid of the Contractor within the time specified in the bid documents, or within such time period as may be agreed to by the Owner and Contractor, and the Contractor either (1) enters into a contract with the Owner in accordance with the terms of such bid, and gives such bond or bonds as may be specified in the bidding or Contract Documents, with a surety admitted in the jurisdiction of the Project and otherwise acceptable to the Owner, for the faithful performance of such Contract and for the prompt payment of labor and material furnished in the prosecution thereof; or (2) pays to the Owner the difference, not to exceed the amount of this Bond, between the amount specified in said bid and such larger amount for which the Owner may in good faith contract with another party to perform the work covered by said bid, then this obligation shall be null and void, otherwise to remain in full force and effect. The Surety hereby waives any notice of an agreement between the Owner and Contractor to extend the time in which the Owner may accept the bid. Waiver of notice by the Surety shall not apply to any extension exceeding sixty (60) days in the aggregate beyond the time for acceptance of bids specified in the bid documents, and the Owner and Contractor shall obtain the Surety's consent for an extension beyond sixty (60) days.

If this Bond is issued in connection with a subcontractor's bid to a Contractor, the term Contractor in this Bond shall be deemed to be Subcontractor and the term Owner shall be deemed to be Contractor.

When this Bond has been furnished to comply with a statutory or other legal requirement in the location of the Project, any provision in this Bond conflicting with said statutory or legal requirement shall be deemed deleted herefrom and provisions conforming to such statutory or other legal requirement shall be deemed incorporated herein. When so furnished, the intent is that this Bond shall be construed as a statutory bond and not as a common law bond.

Signed and sealed this _____ day of _____

_____	(Contractor as Principal)	_____	(Seal)
(Witness)	_____	_____	(Title)
_____	(Surety)	_____	(Seal)
(Witness)	_____	_____	(Title)

CAUTION: You should sign an original AIA Contract Document, on which this text appears in RED. An original assures that changes will not be obscured.

 **AIA**® Document A312™ – 2010

Performance Bond

CONTRACTOR:
(Name, legal status and address)

SURETY:
(Name, legal status and principal place of business)

OWNER:
(Name, legal status and address)

This document has important legal consequences. Consultation with an attorney is encouraged with respect to its completion or modification.

Any singular reference to Contractor, Surety, Owner or other party shall be considered plural where applicable.

AIA Document A312–2010 combines two separate bonds, a Performance Bond and a Payment Bond, into one form. This is not a single combined Performance and Payment Bond.

CONSTRUCTION CONTRACT
Date:

Amount:

Description:
(Name and location)

BOND
Date:
(Not earlier than Construction Contract Date)

Amount:

Modifications to this Bond: None See Section 16

CONTRACTOR AS PRINCIPAL **SURETY**
Company: *(Corporate Seal)* Company: *(Corporate Seal)*

Signature: _____ Signature: _____
Name Nam e
and Title: and Title:
(Any additional signatures appear on the last page of this Performance Bond.)

(FOR INFORMATION ONLY — Name, address and telephone)

AGENT or BROKER: **OWNER'S REPRESENTATIVE:**
(Architect, Engineer or other party:)

§ 1 The Contractor and Surety, jointly and severally, bind themselves, their heirs, executors, administrators, successors and assigns to the Owner for the performance of the Construction Contract, which is incorporated herein by reference.

§ 2 If the Contractor performs the Construction Contract, the Surety and the Contractor shall have no obligation under this Bond, except when applicable to participate in a conference as provided in Section 3.

§ 3 If there is no Owner Default under the Construction Contract, the Surety's obligation under this Bond shall arise after

- .1 the Owner first provides notice to the Contractor and the Surety that the Owner is considering declaring a Contractor Default. Such notice shall indicate whether the Owner is requesting a conference among the Owner, Contractor and Surety to discuss the Contractor's performance. If the Owner does not request a conference, the Surety may, within five (5) business days after receipt of the Owner's notice, request such a conference. If the Surety timely requests a conference, the Owner shall attend. Unless the Owner agrees otherwise, any conference requested under this Section 3.1 shall be held within ten (10) business days of the Surety's receipt of the Owner's notice. If the Owner, the Contractor and the Surety agree, the Contractor shall be allowed a reasonable time to perform the Construction Contract, but such an agreement shall not waive the Owner's right, if any, subsequently to declare a Contractor Default;
- .2 the Owner declares a Contractor Default, terminates the Construction Contract and notifies the Surety; and
- .3 the Owner has agreed to pay the Balance of the Contract Price in accordance with the terms of the Construction Contract to the Surety or to a contractor selected to perform the Construction Contract.

§ 4 Failure on the part of the Owner to comply with the notice requirement in Section 3.1 shall not constitute a failure to comply with a condition precedent to the Surety's obligations, or release the Surety from its obligations, except to the extent the Surety demonstrates actual prejudice.

§ 5 When the Owner has satisfied the conditions of Section 3, the Surety shall promptly and at the Surety's expense take one of the following actions:

§ 5.1 Arrange for the Contractor, with the consent of the Owner, to perform and complete the Construction Contract;

§ 5.2 Undertake to perform and complete the Construction Contract itself, through its agents or independent contractors;

§ 5.3 Obtain bids or negotiated proposals from qualified contractors acceptable to the Owner for a contract for performance and completion of the Construction Contract, arrange for a contract to be prepared for execution by the Owner and a contractor selected with the Owner's concurrence, to be secured with performance and payment bonds executed by a qualified surety equivalent to the bonds issued on the Construction Contract, and pay to the Owner the amount of damages as described in Section 7 in excess of the Balance of the Contract Price incurred by the Owner as a result of the Contractor Default; or

§ 5.4 Waive its right to perform and complete, arrange for completion, or obtain a new contractor and with reasonable promptness under the circumstances:

- .1 After investigation, determine the amount for which it may be liable to the Owner and, as soon as practicable after the amount is determined, make payment to the Owner; or
- .2 Deny liability in whole or in part and notify the Owner, citing the reasons for denial.

§ 6 If the Surety does not proceed as provided in Section 5 with reasonable promptness, the Surety shall be deemed to be in default on this Bond seven days after receipt of an additional written notice from the Owner to the Surety demanding that the Surety perform its obligations under this Bond, and the Owner shall be entitled to enforce any remedy available to the Owner. If the Surety proceeds as provided in Section 5.4, and the Owner refuses the payment or the Surety has denied liability, in whole or in part, without further notice the Owner shall be entitled to enforce any remedy available to the Owner.

§ 7 If the Surety elects to act under Section 5.1, 5.2 or 5.3, then the responsibilities of the Surety to the Owner shall not be greater than those of the Contractor under the Construction Contract, and the responsibilities of the Owner to the Surety shall not be greater than those of the Owner under the Construction Contract. Subject to the commitment by the Owner to pay the Balance of the Contract Price, the Surety is obligated, without duplication, for

- .1 the responsibilities of the Contractor for correction of defective work and completion of the Construction Contract;
- .2 additional legal, design professional and delay costs resulting from the Contractor's Default, and resulting from the actions or failure to act of the Surety under Section 5; and
- .3 liquidated damages, or if no liquidated damages are specified in the Construction Contract, actual damages caused by delayed performance or non-performance of the Contractor.

§ 8 If the Surety elects to act under Section 5.1, 5.3 or 5.4, the Surety's liability is limited to the amount of this Bond.

§ 9 The Surety shall not be liable to the Owner or others for obligations of the Contractor that are unrelated to the Construction Contract, and the Balance of the Contract Price shall not be reduced or set off on account of any such unrelated obligations. No right of action shall accrue on this Bond to any person or entity other than the Owner or its heirs, executors, administrators, successors and assigns.

§ 10 The Surety hereby waives notice of any change, including changes of time, to the Construction Contract or to related subcontracts, purchase orders and other obligations.

§ 11 Any proceeding, legal or equitable, under this Bond may be instituted in any court of competent jurisdiction in the location in which the work or part of the work is located and shall be instituted within two years after a declaration of Contractor Default or within two years after the Contractor ceased working or within two years after the Surety refuses or fails to perform its obligations under this Bond, whichever occurs first. If the provisions of this Paragraph are void or prohibited by law, the minimum period of limitation available to sureties as a defense in the jurisdiction of the suit shall be applicable.

§ 12 Notice to the Surety, the Owner or the Contractor shall be mailed or delivered to the address shown on the page on which their signature appears.

§ 13 When this Bond has been furnished to comply with a statutory or other legal requirement in the location where the construction was to be performed, any provision in this Bond conflicting with said statutory or legal requirement shall be deemed deleted herefrom and provisions conforming to such statutory or other legal requirement shall be deemed incorporated herein. When so furnished, the intent is that this Bond shall be construed as a statutory bond and not as a common law bond.

§ 14 Definitions

§ 14.1 **Balance of the Contract Price.** The total amount payable by the Owner to the Contractor under the Construction Contract after all proper adjustments have been made, including allowance to the Contractor of any amounts received or to be received by the Owner in settlement of insurance or other claims for damages to which the Contractor is entitled, reduced by all valid and proper payments made to or on behalf of the Contractor under the Construction Contract.

§ 14.2 **Construction Contract.** The agreement between the Owner and Contractor identified on the cover page, including all Contract Documents and changes made to the agreement and the Contract Documents.

§ 14.3 **Contractor Default.** Failure of the Contractor, which has not been remedied or waived, to perform or otherwise to comply with a material term of the Construction Contract.

§ 14.4 **Owner Default.** Failure of the Owner, which has not been remedied or waived, to pay the Contractor as required under the Construction Contract or to perform and complete or comply with the other material terms of the Construction Contract.

§ 14.5 **Contract Documents.** All the documents that comprise the agreement between the Owner and Contractor.

§ 15 If this Bond is issued for an agreement between a Contractor and subcontractor, the term Contractor in this Bond shall be deemed to be Subcontractor and the term Owner shall be deemed to be Contractor.

§ 16 Modifications to this bond are as follows:

Sample

(Space is provided below for additional signatures of added parties, other than those appearing on the cover page.)

CONTRACTOR AS PRINCIPAL

SURETY

Company: _____

(Corporate Seal)

Company: _____

(Corporate Seal)

Signature: _____

Name and Title: _____

Address _____

Signature: _____

Name and Title: _____

Address _____

CAUTION: You should sign an original AIA Contract Document, on which this text appears in RED. An original assures that changes will not be obscured.



AIA[®] Document A312[™] – 2010

Payment Bond

CONTRACTOR:

(Name, legal status and address)

SURETY:

(Name, legal status and principal place of business)

OWNER:

(Name, legal status and address)

This document has important legal consequences. Consultation with an attorney is encouraged with respect to its completion or modification.

Any singular reference to Contractor, Surety, Owner or other party shall be considered plural where applicable.

AIA Document A312–2010 combines two separate bonds, a Performance Bond and a Payment Bond, into one form. This is not a single combined Performance and Payment Bond.

CONSTRUCTION CONTRACT

Date:

Amount:

Description:

(Name and location)

BOND

Date:

(Not earlier than Construction Contract Date)

Amount:

Modifications to this Bond: None See Section 18

CONTRACTOR AS PRINCIPAL

Company: *(Corporate Seal)*

SURETY

Company: *(Corporate Seal)*

Signature: _____

Name _____
and Title: _____

Signature: _____

Name _____
and Title: _____

(Any additional signatures appear on the last page of this Payment Bond.)

(FOR INFORMATION ONLY — Name, address and telephone)

AGENT or BROKER:

OWNER'S REPRESENTATIVE:

(Architect, Engineer or other party:)

§ 1 The Contractor and Surety, jointly and severally, bind themselves, their heirs, executors, administrators, successors and assigns to the Owner to pay for labor, materials and equipment furnished for use in the performance of the Construction Contract, which is incorporated herein by reference, subject to the following terms.

§ 2 If the Contractor promptly makes payment of all sums due to Claimants, and defends, indemnifies and holds harmless the Owner from claims, demands, liens or suits by any person or entity seeking payment for labor, materials or equipment furnished for use in the performance of the Construction Contract, then the Surety and the Contractor shall have no obligation under this Bond.

§ 3 If there is no Owner Default under the Construction Contract, the Surety's obligation to the Owner under this Bond shall arise after the Owner has promptly notified the Contractor and the Surety (at the address described in Section 13) of claims, demands, liens or suits against the Owner or the Owner's property by any person or entity seeking payment for labor, materials or equipment furnished for use in the performance of the Construction Contract and tendered defense of such claims, demands, liens or suits to the Contractor and the Surety.

§ 4 When the Owner has satisfied the conditions in Section 3, the Surety shall promptly and at the Surety's expense defend, indemnify and hold harmless the Owner against a duly tendered claim, demand, lien or suit.

§ 5 The Surety's obligations to a Claimant under this Bond shall arise after the following:

§ 5.1 Claimants, who do not have a direct contract with the Contractor,

- .1 have furnished a written notice of non-payment to the Contractor, stating with substantial accuracy the amount claimed and the name of the party to whom the materials were, or equipment was, furnished or supplied or for whom the labor was done or performed, within ninety (90) days after having last performed labor or last furnished materials or equipment included in the Claim; and
- .2 have sent a Claim to the Surety (at the address described in Section 13).

§ 5.2 Claimants, who are employed by or have a direct contract with the Contractor, have sent a Claim to the Surety (at the address described in Section 13).

§ 6 If a notice of non-payment required by Section 5.1.1 is given by the Owner to the Contractor, that is sufficient to satisfy a Claimant's obligation to furnish a written notice of non-payment under Section 5.1.1.

§ 7 When a Claimant has satisfied the conditions of Sections 5.1 or 5.2, whichever is applicable, the Surety shall promptly and at the Surety's expense take the following actions:

§ 7.1 Send an answer to the Claimant, with a copy to the Owner, within sixty (60) days after receipt of the Claim, stating the amounts that are undisputed and the basis for challenging any amounts that are disputed; and

§ 7.2 Pay or arrange for payment of any undisputed amounts.

§ 7.3 The Surety's failure to discharge its obligations under Section 7.1 or Section 7.2 shall not be deemed to constitute a waiver of defenses the Surety or Contractor may have or acquire as to a Claim, except as to undisputed amounts for which the Surety and Claimant have reached agreement. If, however, the Surety fails to discharge its obligations under Section 7.1 or Section 7.2, the Surety shall indemnify the Claimant for the reasonable attorney's fees the Claimant incurs thereafter to recover any sums found to be due and owing to the Claimant.

§ 8 The Surety's total obligation shall not exceed the amount of this Bond, plus the amount of reasonable attorney's fees provided under Section 7.3, and the amount of this Bond shall be credited for any payments made in good faith by the Surety.

§ 9 Amounts owed by the Owner to the Contractor under the Construction Contract shall be used for the performance of the Construction Contract and to satisfy claims, if any, under any construction performance bond. By the Contractor furnishing and the Owner accepting this Bond, they agree that all funds earned by the Contractor in the performance of the Construction Contract are dedicated to satisfy obligations of the Contractor and Surety under this Bond, subject to the Owner's priority to use the funds for the completion of the work.

§ 10 The Surety shall not be liable to the Owner, Claimants or others for obligations of the Contractor that are unrelated to the Construction Contract. The Owner shall not be liable for the payment of any costs or expenses of any Claimant under this Bond, and shall have under this Bond no obligation to make payments to, or give notice on behalf of, Claimants or otherwise have any obligations to Claimants under this Bond.

§ 11 The Surety hereby waives notice of any change, including changes of time, to the Construction Contract or to related subcontracts, purchase orders and other obligations.

§ 12 No suit or action shall be commenced by a Claimant under this Bond other than in a court of competent jurisdiction in the state in which the project that is the subject of the Construction Contract is located or after the expiration of one year from the date (1) on which the Claimant sent a Claim to the Surety pursuant to Section 5.1.2 or 5.2, or (2) on which the last labor or service was performed by anyone or the last materials or equipment were furnished by anyone under the Construction Contract, whichever of (1) or (2) first occurs. If the provisions of this Paragraph are void or prohibited by law, the minimum period of limitation available to sureties as a defense in the jurisdiction of the suit shall be applicable.

§ 13 Notice and Claims to the Surety, the Owner or the Contractor shall be mailed or delivered to the address shown on the page on which their signature appears. Actual receipt of notice or Claims, however accomplished, shall be sufficient compliance as of the date received.

§ 14 When this Bond has been furnished to comply with a statutory or other legal requirement in the location where the construction was to be performed, any provision in this Bond conflicting with said statutory or legal requirement shall be deemed deleted herefrom and provisions conforming to such statutory or other legal requirement shall be deemed incorporated herein. When so furnished, the intent is that this Bond shall be construed as a statutory bond and not as a common law bond.

§ 15 Upon request by any person or entity appearing to be a potential beneficiary of this Bond, the Contractor and Owner shall promptly furnish a copy of this Bond or shall permit a copy to be made.

§ 16 Definitions

§ 16.1 Claim. A written statement by the Claimant including at a minimum:

- .1 the name of the Claimant;
- .2 the name of the person for whom the labor was done, or materials or equipment furnished;
- .3 a copy of the agreement or purchase order pursuant to which labor, materials or equipment was furnished for use in the performance of the Construction Contract;
- .4 a brief description of the labor, materials or equipment furnished;
- .5 the date on which the Claimant last performed labor or last furnished materials or equipment for use in the performance of the Construction Contract;
- .6 the total amount earned by the Claimant for labor, materials or equipment furnished as of the date of the Claim;
- .7 the total amount of previous payments received by the Claimant; and
- .8 the total amount due and unpaid to the Claimant for labor, materials or equipment furnished as of the date of the Claim.

§ 16.2 Claimant. An individual or entity having a direct contract with the Contractor or with a subcontractor of the Contractor to furnish labor, materials or equipment for use in the performance of the Construction Contract. The term Claimant also includes any individual or entity that has rightfully asserted a claim under an applicable mechanic's lien or similar statute against the real property upon which the Project is located. The intent of this Bond shall be to include without limitation in the terms "labor, materials or equipment" that part of water, gas, power, light, heat, oil, gasoline, telephone service or rental equipment used in the Construction Contract, architectural and engineering services required for performance of the work of the Contractor and the Contractor's subcontractors, and all other items for which a mechanic's lien may be asserted in the jurisdiction where the labor, materials or equipment were furnished.

§ 16.3 Construction Contract. The agreement between the Owner and Contractor identified on the cover page, including all Contract Documents and all changes made to the agreement and the Contract Documents.

§ 16.4 **Owner Default.** Failure of the Owner, which has not been remedied or waived, to pay the Contractor as required under the Construction Contract or to perform and complete or comply with the other material terms of the Construction Contract.

§ 16.5 **Contract Documents.** All the documents that comprise the agreement between the Owner and Contractor.

§ 17 If this Bond is issued for an agreement between a Contractor and subcontractor, the term Contractor in this Bond shall be deemed to be Subcontractor and the term Owner shall be deemed to be Contractor.

§ 18 Modifications to this bond are as follows:

(Space is provided below for additional signatures of added parties, other than those appearing on the cover page.)

CONTRACTOR AS PRINCIPAL

Company: _____

(Corporate Seal)

SURETY

Company: _____

(Corporate Seal)

Signature: _____

Name and Title: _____

Address _____

Signature: _____

Name and Title: _____

Address _____

CAUTION: You should sign an original AIA Contract Document, on which this text appears in RED. An original assures that changes will not be obscured.

EQUAL BENEFITS COMPLIANCE PAYMENT CERTIFICATION

PURPOSE

25.016(8) of the Dane County Ordinance requires that each contractor receiving payment for contracted services must certify that he or she has complied fully with the requirements of Chapter 25.016 “Equal Benefits Requirement” of the Dane County Ordinances. Such certification must be submitted prior to the final payment on the contract.

This form should be included with a copy of the final contract invoice forwarded to your contract representative at Dane County.

CERTIFICATION

I, _____ certify that
Printed or Typed Name and Title

Printed or Typed Name of Contractor

has complied fully with the requirements of Chapter 25.016 of the Dane County Ordinances “Equal Benefits Requirements”.

Signed _____

Date _____

For questions on this form, please contact Chuck Hicklin at 608-266-4109 or your contract representative at Dane County.

GENERAL CONDITIONS OF CONTRACT

TABLE OF CONTENTS

1. CONSTRUCTION DOCUMENTS	2
2. DEFINITIONS	2
3. ADDITIONAL INSTRUCTIONS AND DRAWINGS	2
4. SHOP DRAWINGS, PRODUCT DATA AND SAMPLES	2
5. CUTTING AND PATCHING.....	3
6. CLEANING UP	4
7. USE OF SITE.....	4
8. MATERIALS AND WORKMANSHIP	5
9. CONTRACTOR'S TITLE TO MATERIALS	5
10. "OR EQUAL" CLAUSE.....	5
11. PATENTS AND ROYALTIES.....	6
12. SURVEYS, PERMITS, REGULATIONS AND TAXES.....	6
13. CONTRACTOR'S OBLIGATIONS AND SUPERINTENDENCE.....	7
14. WEATHER CONDITIONS.....	7
15. PROTECTION OF WORK AND PROPERTY	8
16. INSPECTION AND TESTING OF MATERIALS.....	8
17. REPORTS, RECORDS AND DATA	8
18. CHANGES IN THE WORK.....	9
19. EXTRAS	10
20. TIME FOR COMPLETION.....	10
21. CORRECTION OF WORK.....	10
22. SUBSURFACE CONDITIONS FOUND DIFFERENT	10
23. RIGHT OF DEPARTMENT TO TERMINATE CONTRACT	11
24. CONSTRUCTION SCHEDULE AND PERIODIC ESTIMATES	11
25. PAYMENTS TO CONTRACTOR	12
26. WITHHOLDING OF PAYMENTS.....	13
27. ACCEPTANCE OF FINAL PAYMENT AS RELEASE	14
28. PAYMENTS BY CONTRACTOR.....	14
29. CONTRACT SECURITY.....	14
30. ASSIGNMENTS.....	14
31. MUTUAL RESPONSIBILITY OF CONTRACTORS	14
32. SEPARATE CONTRACTS	15
33. SUBCONTRACTS	15
34. PUBLIC WORKS PROJECT MANAGER'S AUTHORITY	16
35. ARCHITECT / ENGINEER'S AUTHORITY	16
36. STATED ALLOWANCES	16
37. ESTIMATES OF QUANTITIES	17
38. LANDS AND RIGHTS-OF-WAY	17
39. GENERAL GUARANTEE.....	17
40. CONFLICTING CONDITIONS	17
41. NOTICE AND SERVICE THEREOF	18
42. PROTECTION OF LIVES AND HEALTH	18
43. AFFIRMATIVE ACTION PROVISION AND MINORITY / WOMEN / DISADVANTAGED BUSINESS ENTERPRISES	18
44. COMPLIANCE WITH FAIR LABOR STANDARDS	19
45. DOMESTIC PARTNERSHIP BENEFITS	19
46. USE AND OCCUPANCY PRIOR TO ACCEPTANCE	19
47. MINIMUM WAGES	20
48. CLAIMS	20
49. ANTITRUST AGREEMENT	21
50. INSURANCE.....	21
51. WISCONSIN LAW CONTROLLING	23

1. CONSTRUCTION DOCUMENTS

- A. Construction Documents, listed in Table of Contents of this Specification volume shall form part of this Contract and provisions of Construction Documents shall be as binding upon parties as if they were fully set forth in Contract itself.
- B. These shall also be considered as part of Construction Documents: Addenda, including additions and modifications incorporated in such addenda before execution of Contract; requests for information; construction bulletins; change orders; and written interpretations by Architect / Engineer or Public Works Project Manager that are made after execution of Contract.
- C. Construction Documents are complementary, and what is required by one shall be as binding as if required by all. Intent of Construction Documents is to include all labor, materials and equipment necessary for proper execution of the Work.

2. DEFINITIONS

- A. These terms as used in this Contract are respectively defined as follows:
 - 1. All uses of term “County” in Construction Documents shall mean Dane County.
 - 2. All uses of term “Department” in Construction Documents shall mean Department of Public Works, Highway & Transportation, which is a unit of Dane County government. Department is County agency overseeing Contract with Contractor.
 - 3. Public Works Project Manager is appointed by and responsible to Department. Public Works Project Manager has authority to act on behalf of Department and will sign change orders, payment requests and other administrative matters related to projects.
 - 4. Public Works Project Manager is responsible for supervision, administration and management of field operations involved in construction phase of this Work.
 - 5. Term “Work” includes all labor, equipment and materials necessary to produce project required by Construction Documents.
 - 6. Term “Substantial Completion” is date when project or specified area of project is certified by Architect / Engineer that construction is sufficiently completed, in accordance with Construction Documents, and as modified by any subsequent changes agreed to by parties, so that County may occupy project or specified area of project for use for which it was intended subject to permit approval for occupancy.
 - 7. Contractor is person, firm, or corporation with whom County makes Contract. Though multiple contracts may be involved, Construction Documents treat them throughout as if each were of singular number.

3. ADDITIONAL INSTRUCTIONS AND DRAWINGS

- A. Contractor may be furnished additional instructions and detail drawings as necessary to carry out the Work included in Contract. Additional drawings and instructions thus supplied to Contractor will coordinate with Construction Documents and will be so prepared that they can be reasonably interpreted as part thereof. Contractor shall carry out the Work in accordance with additional detail drawings and instructions.

4. SHOP DRAWINGS, PRODUCT DATA AND SAMPLES

- A. Unless otherwise specified, Contractor shall submit three (3) copies of all Shop Drawings for each submission, until receiving final approval. After final approval, provide five (5) additional copies for distribution and such other copies as may be required.

- B. Contractor shall submit, on an on-going basis and as directed, Product Data such as brochures that shall contain catalog cuts and specifications of all furnished mechanical and electrical equipment. After Architect / Engineer's approval, one (1) copy shall remain in Architect / Engineer's file, one (1) kept at Department's office and one (1) kept at job site by Contractor for reference purposes.
- C. Samples shall consist of physical examples furnished by Contractor in sufficient size and quantity to illustrate materials, equipment or workmanship, and to establish standards to compare the Work.
 - 1. Submit Samples in sufficient quantity (minimum of two (2)) to permit Architect / Engineer to make all necessary tests and of adequate size showing quality, type, color range, finish, and texture. Label each Sample stating material, type, color, thickness, size, project name, and Contractor's name.
 - 2. Submit transmittal letter requesting approval, and prepay transportation charges to Architect / Engineer's office on samples forwarded.
 - 3. Materials installed shall match approved Samples.
- D. Contractor shall review Shop Drawings and place their dated stamp thereon to evidence their review and approval and shall submit with reasonable promptness and in orderly sequence to cause no delay in the Work or in work of any other contractor. At time of submission, Contractor shall inform Architect / Engineer in writing of any deviation in Shop Drawings or Samples from requirements of Construction Documents. Architect / Engineer will not consider partial lists.
- E. Architect / Engineer will review and approve or reject Shop Drawings with reasonable promptness to cause no delay. Architect / Engineer's approval shall not relieve Contractor from responsibility for errors or omissions in Shop Drawings.
- F. Contractor shall not commence any work requiring Shop Drawing, Product Data or Sample submission until Architect / Engineer has approved submission. All such work shall be in accordance with approved Shop Drawings, Product Data and Samples.
- G. Contractor shall keep on site of the Work, approved or conformed copy of Shop Drawings and shall at all time give Department access thereto.
- H. By stamping and submitting Shop Drawings, Product Data and Samples, Contractor thereby represents that he or she has or will determine and verify all field measurements, field construction criteria, materials, catalog numbers, and similar data and that he or she has checked and coordinated each Shop Drawing, Product Data and Sample with requirements of the Work and of Construction Documents. Architect / Engineer shall return without examination, Shop Drawings, Product Data and Samples not so noted.
- I. All Shop Drawings from any one Contractor should be numbered consecutively and on cover sheet shall bear name and location of project, name of Contractor, date of submittal and date of each correction or revision and associated Specification section and page number.

5. CUTTING AND PATCHING

- A. Contractor shall be responsible for all cutting, fitting or patching required to complete the Work or to make its parts fit together properly.

- B. Contractor shall not damage or endanger portion of the Work or fully or partially completed construction of County or separate contractors by cutting, patching or otherwise altering such construction, or by excavation. Contractor shall not cut or otherwise alter such construction by County or separate contractor except with written consent of County and of such separate contractor; such consent shall not be unreasonably withheld. Contractor shall not withhold unreasonably from County or separate contractor, Contractor's consent to cutting or otherwise altering the Work.

6. CLEANING UP

- A. Contractor shall keep premises and surrounding area free from accumulation of waste materials or rubbish caused by operations under Contract. Contractor shall remove from and about the Work waste materials, rubbish, Contractor's tools, construction equipment, machinery, and surplus materials at completion of the Work. Contractor shall maintain streets and sidewalks around the Work site in clean condition. Contractor shall remove all spillage and prevent tracking of spillage arising from performance of the Work, into, out of, and within the Work site. Contractor shall establish regular maintenance program of sweeping, vacuuming and / or hosing to minimize accumulation of dirt and dust upon such areas.
- B. If Contractor fails to clean up as directed in Construction Documents, County may do so and shall charge Contractor cost thereof.
- C. Contractor shall be responsible for broken windows and glass, and at completion of the Work shall replace such damaged or broken windows and glass. After replacing damaged or broken windows and glass, Contractor shall remove all labels, wash and polish both sides of all windows and glass.
- D. In addition to general cleaning (sweeping, vacuuming and / or hosing, as is appropriate to work surface), Contractor shall perform following final cleaning for all trades at completion of the Work:
 - 1. Remove temporary protections;
 - 2. Remove marks, stains, fingerprints and other soil or dirt from painted, decorated and finished woodwork and wall surfaces;
 - 3. Remove spots, plaster, soil and paint from ceramic tile, marble and other finished materials, and wash or wipe clean;
 - 4. Clean fixtures, cabinet work and equipment, removing stains, paint, dirt and dust, and leave same in undamaged, new condition;
 - 5. Clean aluminum in accordance with recommendations of manufacturer; and
 - 6. Clean resilient floors thoroughly with well-rinsed mop containing only enough moisture to clean off any surface dirt or dust and buff dry by machine to bring surfaces to sheen.

7. USE OF SITE

- A. Contractor shall provide County and Architect / Engineer access to the Work under all circumstances.
- B. Contractor shall confine operations at site to areas permitted by County, law, ordinance, permits and Construction Documents and shall not unreasonably encumber site with materials or equipment. Contractor shall assure free, convenient, unencumbered, direct and safe access to all properties adjacent to the Work for County, its employees, invitees and guests.

8. MATERIALS AND WORKMANSHIP

- A. Contractor shall perform all work and furnish all supplies and materials, machinery, equipment, facilities and means, necessary to complete the Work required by this Contract, within time specified, in accordance with provisions of Construction Documents.
- B. All equipment and materials incorporated in the Work covered by this Contract are to be new; use recycled and / or recovered materials to extent that such use is technically and economically feasible. Recovered materials are products recovered from solid waste in form identical to original form for use that is same as, or similar to original use. Recycled materials are products manufactured from solid waste.
- C. If requested, Contractor shall furnish satisfactory evidence as to kind and quality of construction materials proposed or used. Contractor shall furnish to Architect / Engineer, for approval, manufacturer name and model, performance capacities and other pertinent information of machinery, mechanical, electrical or other types of equipment, which Contractor plans to install.
- D. If not otherwise provided, materials and labor called for in this Contract shall be provided and performed in accordance with established practice and standards recognized by Architects, Engineers, Department, and construction industry.
- E. Reference to “Standard” specifications of any association or manufacturer, or codes of County authorities, intends most recent printed edition or catalog in effect on date that corresponds with date of Construction Documents.
- F. Whenever reference is made in Specifications that work shall be “performed”, “applied”, in accordance with “manufacturer’s directions or instructions”, Contractor to whom those instructions are directed shall furnish three (3) printed copies of such instructions to Architect / Engineer before execution of the Work.

9. CONTRACTOR’S TITLE TO MATERIALS

- A. Contractor or any subcontractor shall not purchase materials or supplies for the Work subject to any chattel mortgage or under conditional sale contract or other agreement by which seller retains interest. Contractor warrants that all materials and supplies used in the Work are free from all liens, claims or encumbrances and Contractor has good title to them.

10. “OR EQUAL” CLAUSE

- A. Whenever equipment or materials are identified on Drawings or in Specifications by reference to manufacturer’s or vendor’s name, trade name, catalog number, and other identifying information, it is intended to establish standards; and any equipment or material of other manufacturers and vendors which will perform adequately duties imposed by general design will be considered equally accepted provided equipment or material so proposed is, in opinion of Architect / Engineer, of equal substance and function. Architect / Engineer and Department shall provide written approval before Contractor may purchase or install it.
- B. Equipment or materials of manufacturers, other than those named, may be used only upon following conditions:
 - 1. That, in opinion of Architect / Engineer and Department, proposed material or equipment item is fully equal or superior (in design, materials, construction, workmanship,

- performance, finish, etc.) to named item. No compromise in quality level, however small, is acceptable.
2. That, in substituting materials or equipment, Contractor assumes responsibility for any changes in system or for modifications required in adjacent or related work to accommodate such substitution despite Architect / Engineer's and Department's approval, and all costs growing out of approval of "or equal" items shall be responsibility of Contractor. No extra costs resulting from such approval shall become responsibility of Department, Architect / Engineer or any other separate Contractor.
 3. It shall be understood that use of materials or equipment other than those specified, or approved equal by Architect / Engineer and Department, shall constitute violation of Contract, and that Architect / Engineer and Department shall have right to require removal of such materials or equipment and their replacement with specified materials or equipment at Contractor's expense.
 4. Product and manufacturer named first in Specifications or on information shown on Drawings is basis of selection of manufactured items and equipment, particularly mechanical equipment. In using other than first named products or manufacturers, including those specified as additionally approved or acceptable, Contractor assumes responsibility for any changes in system and for modifications in any work required to accommodate them. Architect / Engineer's approval of such additionally acceptable products or manufacturers, either in Specifications or in Addendum, does not relieve Contractor from obligation to coordinate such optional products with other Contractors, whose work may be affected by them, and to pay all additional costs resulting from their inclusion into the Work. Contractor's liability shall include payment of Architect / Engineer's fees for any additional services made necessary by or directly connected to such product changes. No extra costs resulting from such changes shall become responsibility of Department, Architect / Engineer or any other separate Contractor.
- C. No request for approval of "or equal" materials will be entertained except from Contractor. Identify any request for substitution as substitution on Contractor's letter of transmittal and give reasons for substitution. Department may in its sole discretion allow substitutions of materials.

11. PATENTS AND ROYALTIES

- A. If Contractor uses any design, device or material covered by letters, patent or copyright, it is mutually agreed and understood, that, without exception, contract prices shall include all royalties or costs arising from use of such design, device or materials, in any way involved in the Work.
- B. Contractor shall indemnify and save harmless County from any and all claims for infringement by reason of use of such patent or copyright in connection with the Work agreed to be performed under this Contract, and shall indemnify County for any cost, expense or damage which it may be obliged to pay by reason of such infringement at any time during prosecution of the Work or after completion of the Work.

12. SURVEYS, PERMITS, REGULATIONS AND TAXES

- A. Department will furnish to Contractor all site, topography and property surveys necessary for execution of the Work.
- B. Contractor shall procure all permits, licenses and approvals necessary for execution of this Contract.

- C. Contractor shall give all notices and comply with all State of Wisconsin, Federal and local laws, codes, rules and regulations relating to performance of the Work, protection of adjacent property, and maintenance of passageways, guard fences or other protective facilities.
- D. Contractor shall pay all Sales, Consumer, Use and other similar taxes required by law.
- E. Contractor shall promptly notify Architect / Engineer of any variances of Drawings or Specifications with that of any State of Wisconsin, federal or local law, code, rule or regulation. Upon such notification, Architect / Engineer will require correction of variance to comply with applicable law, code, rule or regulation at no additional cost to Contractor.
- F. Work under this Contract shall comply with all applicable State of Wisconsin, Federal and local laws, codes and regulations.
- G. Contractor shall pay charges for water, sewer and other utility connections made by municipalities where required by Specifications.

13. CONTRACTOR'S OBLIGATIONS AND SUPERINTENDENCE

- A. Contractor shall provide and pay for all materials, labor, tools, equipment, transportation and superintendence necessary to execute, complete and deliver the Work within specified time. Contractor agrees to secure at their own expense all personnel necessary to carry out the Work. Such personnel shall not be deemed County employees nor shall they have or be deemed to have any direct contractual relationship with County.
- B. Performance of any work necessary after regular working hours, on Sundays or Legal Holidays shall be without additional expense to County. Performance of any work at site at other than normal working hours must be coordinated with Public Works Project Manager.
- C. Contractor shall furnish, erect, maintain and remove such temporary works as may be required.
- D. Contractor shall observe, comply with, and be subject to all terms, conditions, requirements and limitations of Construction Documents.
- E. At the Work site, Contractor shall give personal superintendence to the Work or shall employ construction superintendent or foreman, experienced in character of work covered by Contract, who shall have full authority to act for Contractor. Understand that such superintendent or foreman shall be acceptable to Architect / Engineer and Department.
- F. Remove from project or take other corrective action upon notice from Architect / Engineer or Department for Contractor's employees whose work is considered by Architect / Engineer or Department to be unsatisfactory, careless, incompetent, unskilled or otherwise objectionable.
- G. Contractor and subcontractors shall be required to conform to Labor Laws of State of Wisconsin and various acts amendatory and supplementary thereto and to other laws, ordinances and legal requirements applicable to the Work.
- H. Presence and observation of the Work by Architect / Engineer or Public Works Project Manager shall not relieve Contractor of any obligations.

14. WEATHER CONDITIONS

- A. In event of temporary suspension of work, or during inclement weather, or whenever Architect / Engineer shall direct, Contractor shall, and shall cause subcontractors to protect carefully all work and materials against damage or injury from weather. If, in opinion of Architect / Engineer or Department, any work or materials that have been damaged or injured due to failure on part of Contractor or any subcontractors so to protect the Work, such materials shall be removed and replaced at expense of Contractor.

15. PROTECTION OF WORK AND PROPERTY

- A. Contractor shall at all times safely guard County's property from injury or loss in connection with this Contract. Contractor shall at all times safely guard and protect the Work, and adjacent property, from damage. Contractor shall replace or make good any such damage, loss or injury unless such is caused directly by errors contained in Contract, or by County, or County's duly authorized representative.
- B. Contractor may act diligently, without previous instructions from Architect / Engineer and / or Department, in emergency that threatens loss or injury of property, or safety of life. Contractor shall notify Architect / Engineer and / or Department immediately thereafter. Promptly submit any claim for compensation by Contractor due to such extra work to Architect / Engineer and / or Department for approval as provided for in Article 18 herein.

16. INSPECTION AND TESTING OF MATERIALS

- A. Authorized representatives and agents of County government shall have access at all times to the Work wherever it is in preparation or progress and Contractor shall provide facilities for such access and for inspection.
- B. Should it be considered necessary or advisable at any time before final acceptance of the Work to make examination of work already completed, by removing or tearing out same, Contractor shall upon request, promptly furnish all necessary facilities, labor and materials. If such work is found to be defective in any aspect, due to fault of Contractor or subcontractors thereof, Contractor shall assume all expenses of such examination and of satisfactory reconstruction. Contractor will be reimbursed for such examination and replacement in accordance with Article 18 - A.3., of these General Conditions of Contract if such work is found to meet requirements of Contract.
- C. If Specifications, Architect / Engineer's, or Public Works Project Manager's instructions require any work to be specially tested or approved, Contractor shall give Architect / Engineer and Public Works Project Manager timely notice of its readiness for testing or inspection. Test all materials and equipment requiring testing in accordance with accepted or specified standards, as applicable. Architect / Engineer shall recommend laboratory or inspection agency and Department will select and pay for all initial laboratory inspection services. Should retesting be required, due to failure of initial testing, cost of such retesting shall be borne by Contractor.
- D. Cost of any testing performed by manufacturers or Contractor for substantiating acceptability of proposed substitution of materials and equipment, or necessary conformance testing in conjunction with manufacturing processes or factory assemblage, shall be borne by Contractor or manufacturer responsible.

17. REPORTS, RECORDS AND DATA

- A. Contractor shall submit to Architect / Engineer and Public Works Project Manager such schedule of quantities and costs, progress schedules, payrolls, reports, estimates, invoices, records and other data as either may request concerning work performed or to be performed under this Contract.

18. CHANGES IN THE WORK

- A. Make no changes, except in cases of emergency, in the Work covered by approved Construction Documents without having prior written approval of Department. Charges or credits for the Work covered by approved change shall be determined by one of these methods:
1. Unit bid prices previously approved.
 2. Agreed lump sum based on actual cost of:
 - a) Labor, including foremen, and all fringe benefits that are associated with their wages.
 - b) Materials entering permanently into the Work.
 - c) Ownership or rental cost of construction tools and equipment during time of use on extra work.
 - d) Power and consumable supplies for operation of power equipment.
 - e) Workmen's Compensation Insurance, Contractor's Public Liability and Property Damage Insurance, and Comprehensive Automobile Liability Insurance.
 - f) Social Security and old age and unemployment contributions.
 - g) Add to cost under (2), fixed fee to be agreed upon, but not to exceed fifteen percent (15%) of actual cost of work performed with their own labor force. Fee shall be compensation to cover cost of supervision, overhead, bond, profit and any other general expense.
 - h) On that portion of the Work under (2) done under subcontract, Contractor may include not over seven and one-half percent (7½%) for supervision, overhead, bond, profit and any other general expense.
 - i) Department may require correct amount of costs with supporting vouchers; Contractor shall keep and present in such form as directed.
 3. Cost-plus work, with not-to-exceed dollar limit, based on actual cost of:
 - a) Labor, including foremen, and all fringe benefits that are associated with their wages.
 - b) Materials entering permanently into the Work.
 - c) Ownership or rental cost of construction tools and equipment during time of use on extra work. Rental cost cannot exceed fifty percent (50%) replacement value of rented equipment.
 - d) Power and consumable supplies for operation of power equipment.
 - e) Workmen's Compensation Insurance, Contractor's Public Liability and Property Damage Insurance, and Comprehensive Automobile Liability Insurance.
 - f) Social Security and old age and unemployment contributions.
 - g) To cost under (3), there shall be added fixed fee to be agreed upon but not to exceed fifteen percent (15%) of actual cost of work performed with their own labor force. Fee shall be compensation to cover cost of supervision, overhead, bond, profit, and any other general expense.
 - h) On that portion of the Work under (3) done under subcontract, Contractor may include not over seven and one-half percent (7½%) for supervision, overhead, bond, profit, and any other general expense.
 - i) Contractor shall keep and present, in such form as directed, correct amount of cost together with such supporting vouchers as may be required by Department.
- B. If Contractor claims that by any instructions given by Architect / Engineer, Department, by drawings or otherwise, regarding performance of the Work or furnishing of material under Contract, involves extra cost, Contractor shall give Department written notice of cost thereof

within two (2) weeks after receipt of such instructions and in any event before proceeding to execute work, unless delay in executing work would endanger life or property.

- C. No claim for extra work or cost shall be allowed unless it was done in pursuance of written Change Order from Architect / Engineer and approved by Department, as previously mentioned, and claim presented with payment request submitted after changed or extra work is completed.
- D. Negotiation of cost for change in the Work shall not be cause for Contractor to delay prosecution of the Work if Contractor has been authorized in writing by Public Works Project Manager to proceed.

19. EXTRAS

- A. Without invalidating Contract, Department may order extra work or make changes by altering, adding to or deducting from the Work, contract sum being adjusted in accordance with Article 18 herein.

20. TIME FOR COMPLETION

- A. Contractor agrees that the Work shall be prosecuted regularly and diligently and complete the Work as stated in Construction Documents.

21. CORRECTION OF WORK

- A. All work, all materials whether incorporated in the Work or not, and all processes of manufacture shall at all times and places be subject to inspection of Architect / Engineer and Public Works Project Manager who shall be judge of quality and suitability of the Work, materials, and processes of manufacture for purposes for which they are used. Should they fail to meet Architect / Engineer's and Public Works Project Manager's approval they shall be reconstructed, made good, replaced or corrected, by Contractor at Contractor's expense. Immediately remove all rejected material from site.
- B. If Contractor defaults or neglects to carry out the Work in accordance with Construction Documents or fails to perform any provision of Contract, Department may, after ten (10) business days' written notice to Contractor and without prejudice to any other remedy County may have, make good such deficiencies. In such case, appropriate Change Order shall be issued deducting from Contractor's payments then or thereafter, cost of correcting such deficiencies, including cost of Architect / Engineer's additional services made necessary by such default, neglect or failure.

22. SUBSURFACE CONDITIONS FOUND DIFFERENT

- A. If Contractor encounters subsurface or latent conditions at site materially differing from those shown on Drawings or indicated in Specifications, Contractor shall immediately give notice to Architect / Engineer and Public Works Project Manager of such conditions before they are disturbed. Architect / Engineer will thereupon promptly investigate conditions, and if Architect / Engineer finds that they materially differ from those shown on Drawings or indicated in Specifications, Architect / Engineer will at once make such changes as necessary, any increase or decrease of cost resulting from such changes to be adjusted in manner provided in above Article 18 entitled "Changes in the Work".

23. RIGHT OF DEPARTMENT TO TERMINATE CONTRACT

- A. In event that any provisions of this Contract are violated by Contractor or by any subcontractors, County may serve written notice upon Contractor and Surety of its intention to terminate Contract, such notice to contain reasons for such intention to terminate Contract, and unless within ten (10) business days after serving of such notice upon Contractor, such violation or delay shall cease and satisfactory arrangement or correction be made, Contract shall, upon expiration of said ten (10) business days, cease and terminate.
- B. In event of any such termination, County shall immediately serve notice thereof upon Surety and Contractor, and Surety shall have right to take over and perform Contract subject to County's approval; provided, however, that if Surety does not commence performance thereof within ten (10) business days from date of mailing to such Surety of notice of termination, County may take over the Work and prosecute same to completion by contract, or by force account, at expense of Contractor; Contractor and Surety shall be liable to County for any excess cost occasioned County thereby, and in such event County may take possession of and utilize in completing the Work, such materials and equipment as may be on the Work site and therefore necessary.

24. CONSTRUCTION SCHEDULE AND PERIODIC ESTIMATES

- A. Contractor shall be responsible for Construction Schedule and coordination. Immediately after execution and delivery of Contract and before making first payment, Contractor shall notify all subcontractors to furnish all required information to develop Construction Schedule. Contractor and all subcontractors associated with the Work shall furnish following information from each Division of Specifications:
 - 1. List of construction activities;
 - 2. Start, finish and time required for completion of each activity;
 - 3. Sequential relationships between activities;
 - 4. Identify all long lead-time items, key events, meetings or activities such as required submittals, fabrication and delivery, procurement of materials, installation and testing;
 - 5. Weekly definition of extent of work and areas of activity for each trade or Subcontract; and
 - 6. Other information as determined by Public Works Project Manager.
- B. In addition to above requested items, Contractor shall request delivery dates for all County-furnished equipment, materials or labor. This shall include any work handled by Department under separate contracts such as asbestos abatement, air and water balancing, etc. Indicate on Construction Schedule these associated delivery and installation dates.
- C. Progress Reporting:
 - 1. Contractor shall update and publish Construction Schedule on monthly basis. Revisions to Schedule shall be by Contractor and made in same detail as original Schedule and accompanied by explanation of reasons for revision; and shall be subject to approval by Department.
 - 2. Failure of Contractor to keep Schedule in updated format shall result in County hiring firm specializing in construction schedule development and deducting those costs associated with updating process from payments due Contractor.
 - 3. Contractor shall submit show actual percentage of each activity completed, estimated future progress, and anticipated completion time.
- D. Responsibility for timely completion requires:

1. Contractor and subcontractors understand that performance of each is interdependent upon performance of others.
 2. Whenever it becomes apparent from current schedule, that phasing or progress completion dates will not be met, Contractor must take some or all following actions at no additional cost to County:
 - a) Increase construction labor in such quantities and crafts as will eliminate backlog of work.
 - b) Increase number of working hours per shift, shifts per working day, working days per week, amount of construction equipment, or any combination of foregoing to eliminate backlog of work.
 - c) Reschedule work (yet remain in conformance with Drawings and Specifications).
 3. Prior to proceeding with any of above actions, Contractor shall notify Public Works Project Manager.
- E. Maintain current Construction Schedule at all times. Revise Construction Schedule in same detail as original and accompany with explanation of reasons for revision. Schedule shall be subject to approval by Architect / Engineer and Public Works Project Manager.

25. PAYMENTS TO CONTRACTOR

- A. Contractor shall provide:
1. Detailed estimate giving complete breakdown of contract price by Specification Division; and
 2. Periodic itemized estimates of work done for purpose of making partial payments thereon.
- B. Submit these estimates for approval first to Architect / Engineer, then to Public Works Project Manager. Costs employed in making up any of these schedules are for determining basis of partial payments and not considered as fixing basis for additions to or deductions from Contract price.
- C. County will make partial payments to Contractor for value, proportionate to amount of Contract, of all labor and material incorporated in the Work during preceding calendar month upon receipt of Application and Certificate for Payment form from Architect / Engineer and approval of Department.
- D. Contractor shall submit for approval first to Architect / Engineer, and then to Public Works Project Manager all Application and Certificate for Payment forms. If requested, Application and Certificate for Payment shall be supported by such additional evidence as may be required, showing Contractor's right to payment claimed.
- E. Application and Certificate for Payment for preparatory work and materials delivered and suitably stored at site to be incorporated into the Work at some future period, will be given due consideration. Requesting payment for materials stored off site, may be rejected, however, if deemed essential for reasons of job progress, protection, or other sufficient cause, requests will be considered, conditional upon submission by Contractor of bills of sale, photographs and such other procedures as will adequately protect County's interest such as storage in bonded warehouse with adequate coverage. If there is any error in payment, Contractor is obligated to notify Department immediately, but no longer than ten (10) business days from receipt of payment.
- F. Payments by County will be due within forty-five (45) business days after receipt by Department of Application and Certificate for Payment.

- G. County will retain five percent (5%) of each Application and Certificate for Payment until final completion and acceptance of all the Work covered by Contract. However, anytime after fifty percent (50%) of the Work has been furnished and installed at site, County will make remaining payments in full if Architect / Engineer and Public Works Project Manager find that progress of the Work corresponds with Construction Schedule. If Architect / Engineer and Public Works Project Manager find that progress of the Work does not correspond with Construction Schedule, County may retain up to ten percent (10%) of each Application and Certificate for Payment for the Work completed.
- H. All material and work covered by partial payments made shall become sole property of County, but this provision shall not be construed as relieving Contractor from sole responsibility for care and protection of materials and work upon which payments have been made, or restoration of any damaged work, or as waiver of right of County to require fulfillment of all of terms of Contract.
- I. County will make final payment within sixty (60) calendar days after final completion of the Work, and will constitute acceptance thereof. Submit Equal Benefits Compliance Payment Certification with final pay request. Payment may be denied if Certification is not included.
- J. County may make payment in full, including retained percentages and less authorized deductions, upon completion and acceptance of each Division where price is stated separately in Contract.
- K. Every contractor engaged in performance of any contract for Department of Public Works, Highway & Transportation shall submit to this Department, as requested and with final application for payment for work under said contract, affidavit(s) as required to prove that all debts and claims against this Work are paid in full or otherwise satisfied, and give final evidence of release of all liens against the Work and County. If Wisconsin Prevailing Wage Rate Determination is required for this Work, use "Prime Contractor Affidavit of Compliance with Prevailing Wage Rate Determination" and "Agent or Subcontractor Affidavit of Compliance with Prevailing Wage Rate Determination" (if applicable). If Wisconsin Prevailing Wage Rate Determination is not required for this Work, use "Dane County, Wisconsin Contractor Wage Affidavit". Forms of such affidavits are included in Supplementary Conditions.

26. WITHHOLDING OF PAYMENTS

- A. County, after having served written notice on said Contractor, may either pay directly any unpaid bills of which Department has written notice, or withhold from Contractor's unpaid compensation sum of money deemed reasonably sufficient to pay any and all such lawful claims until satisfactory evidence is furnished that all liabilities have been fully discharged; whereupon, payment to Contractor shall be resumed in accordance with terms of this Contract, but in no event shall these provisions be construed to impose any obligations upon County to either Contractor or Contractor's Surety.
- B. In paying any unpaid bills of Contractor, County shall be deemed agent of Contractor, and any payment so made by County, shall be considered as payment made under Contract by County to Contractor and County shall not be liable to Contractor for any such payment made in good faith.
- C. Contractor shall indemnify, hold harmless and defend Dane County, its boards, commissions, agencies, officers, employees and representatives from all claims growing out of lawful

demands of subcontractors, laborers, workers, mechanics, material men, and furnishers of machinery and parts thereof, equipment, power tools, and all supplies, including commissary, incurred in performance of this Contract.

- D. At Department's request, Contractor shall furnish satisfactory evidence that all obligations of nature designated above have been paid, discharged or waived.

27. ACCEPTANCE OF FINAL PAYMENT AS RELEASE

- A. Making of final payment shall constitute waiver of all claims by County except those arising from:
1. Unsettled lien;
 2. Faulty or defective work appearing after substantial completion;
 3. Failure of the Work to comply with requirements of Construction Documents; or
 4. Terms of any special guarantees required by Construction Documents.
- B. Acceptance of final payment shall constitute waiver of all claims by Contractor.

28. PAYMENTS BY CONTRACTOR

- A. Contractor shall pay following not later than fifth (5th) business day following each payment received from County:
1. All transportation and utility services rendered;
 2. All materials, tools, and other expendable equipment that have been delivered at site of the Work to extent of ninety percent (90%) of cost thereof, and balance of cost thereof when said balance is paid to Contractor; and
 3. Each subcontractor, respective amount allowed Contractor because of work performed by subcontractor to extent of subcontractor's interest therein.

29. CONTRACT SECURITY

- A. Contractor shall furnish Performance and Payment Bonds in amount at least equal to one hundred percent (100%) of Contract price as security for faithful performance of this Contract and payment of all persons performing labor on project under this Contract and furnishing materials in connection with this Contract.
- B. Sample Performance and Payment Bonds that Contractor will be required to execute is bound into these Construction Documents. Before construction Contract is consummated, completed Performance and Payment Bonds must be approved by Department.

30. ASSIGNMENTS

- A. Contractor shall not assign whole or any part of this Contract or any moneys due or to become due hereunder without written consent of Department. In case Contractor assigns all or any part of any moneys due or to become due under this Contract, instrument of assignment shall contain clause substantially to effect that it is agreed that right of assignee in and to any moneys due or to become due to Contractor shall be subject to prior claims of all persons, firms and corporations for services rendered or materials supplied for performance of the Work called for in this Contract.

31. MUTUAL RESPONSIBILITY OF CONTRACTORS

- A. If, through acts of neglect on part of Contractor or any subcontractor shall suffer loss or damage on the Work, Contractor agrees to settle with such subcontractor by agreement or arbitration if such other subcontractor will so settle. If such subcontractor shall assert any claim against County on account of any damage alleged to have been sustained, Department shall notify Contractor, who shall indemnify, hold harmless and defend Dane County, its boards, commissions, agencies, officers, employees and representatives against any such claim.

32. SEPARATE CONTRACTS

- A. Department may award other contracts for the Work and all Contractors shall fully cooperate with each other and carefully adjust their work to that provided under other contracts as may be directed by Department. No Contractor shall commit or permit any act that will interfere with performance of the Work by any other Contractor.
- B. Contractor shall coordinate the Work with those of other Contractors. Cooperation will be required in arrangement for storage of materials and in detailed execution of the Work. Contractor, including subcontractors, shall keep informed of progress and detail work of others and shall notify Architect / Engineer or Department immediately of lack of progress or defective workmanship on part of others. Failure of Contractor to keep informed of the Work progressing on site and failure to give notice of lack of progress or defective workmanship by others shall be construed as acceptance by Contractor of status of the Work as being satisfactory for proper coordination with Contractor's own work.

33. SUBCONTRACTS

- A. Contractor may use services of specialty subcontractors on those parts of the Work that, under normal contracting practices, are performed by specialty subcontractors.
- B. Contractor shall not award any work to any subcontractor without prior approval of Department. Qualifications of subcontractors shall be same as qualifications of Contractor. Request for subcontractor approval shall be submitted to Department fifteen (15) business days before start of subcontractor's work. If subcontractors are changed or added, Contractor shall notify Department in writing.
- C. Contractor shall be as fully responsible to County for acts and omissions of subcontractors, and of persons either directly or indirectly employed by them, as Contractor is for acts and omissions of persons directly employed by Contractor.
- D. Contractor shall cause appropriate provisions to be inserted in all subcontracts relative to the Work to bind subcontractors to Contractor by terms of General Conditions of Contract and other Construction Documents insofar as applicable to work of subcontractors and to give Contractor same power as regards terminating any subcontract that Department may exercise over Contractor under any provision of Construction Documents.
- E. Nothing contained in this Contract shall create any contractual relation between any subcontractor and County.
- F. Contractor shall insert in all subcontracts, Articles 26, 33, 43 and 45, respectively entitled: "Withholding of Payments", "Subcontracts", "Affirmative Action Provision and Minority / Women / Disadvantaged Business Enterprises", and "Minimum Wages", and shall further require all subcontractors to incorporate physically these same Articles in all subcontracts.

34. PUBLIC WORKS PROJECT MANAGER'S AUTHORITY

- A. Public Works Project Manager shall:
 - 1. Administer and ensure compliance with Construction Documents;
 - 2. Provide responsible on-site observations of construction and have authority to request work and to stop work whenever necessary to insure proper enforcement of Construction Documents;
 - 3. Convene and chair project meetings and foreman's coordination meetings when necessary to coordinate resolution of conflicts between Contractors, Architects, Engineers, Consultants, and Department; and
 - 4. Check and inspect material, equipment and installation procedures of all trades for proper workmanship and for compliance with Drawings, Specifications and Shop Drawings, permit no material on project site that is not satisfactory and reject work not in compliance with Construction Documents.

35. ARCHITECT / ENGINEER'S AUTHORITY

- A. Architect / Engineer is retained by, and is responsible to Department acting for County.
- B. Architect / Engineer shall determine amount, quality, acceptability, and fitness of several kinds of work and materials that are provided under this Contract and shall decide all questions that may arise in relation to said work and construction thereof.
- C. Architect / Engineer shall decide meaning and intent of any portion of Specifications and of any Drawings where they may be found obscure or be in dispute.
- D. Architect / Engineer shall provide responsible observation of construction. Architect / Engineer has authority to stop the Work whenever such stoppage may be necessary to insure proper execution of Construction Documents.
- E. Architect / Engineer shall be interpreter of conditions of Construction Documents and judge of its performance.
- F. Within reasonable time, Architect / Engineer shall make decisions on all matters relating to progress of the Work or interpretation of Construction Documents.
- G. Architect / Engineer's decisions are subject to review by Public Works Project Manager.

36. STATED ALLOWANCES

- A. Stated allowances enumerated in Instructions to Bidders shall cover net cost of materials or equipment, and all applicable taxes. Contractor's cost of delivery and unloading at site, handling costs on site, labor, installation costs, overhead, profit and any other incidental costs shall be included in Contractor's bid, but not as part of cash allowance.
- B. Department will solicit at least two (2) bids on materials or equipment for which allowance is stated and select on basis of lowest qualified responsible bid. Contractor will then be instructed to purchase "Allowed Materials". If actual price for purchasing "Allowed Materials", including taxes, is more or less than "Cash Allowance", Contract price shall be adjusted accordingly. Adjustment in Contract price shall not contain any cost items excluded from cash allowance.

37. ESTIMATES OF QUANTITIES

- A. Whenever estimated quantities of work to be done and materials to be furnished under this Contract are shown in any of Construction Documents, they are given for use in comparing bids and right is especially reserved to increase or diminish them as they may be deemed reasonably necessary or desirable by Department to complete the Work included in this Contract, and cost for such increase or diminution shall be adjusted in manner provided for in General Conditions of Contract Article 18 entitled "Changes in the Work".

38. LANDS AND RIGHTS-OF-WAY

- A. Prior to start of construction, County shall furnish all land and rights-of-way necessary for carrying out and completion of the Work to be performed under this Contract.

39. GENERAL GUARANTEE

- A. Neither final certificate of payment nor any provision in Construction Documents nor partial or entire occupancy of premises by County shall constitute acceptance of work not done in accordance with Construction Documents or relieve Contractor of liability in respect to any expressed warranties or responsibility for faulty materials or workmanship.
 - 1. In no event shall making of any payment required by Contract constitute or be construed as waiver by County of any breach of covenants of Contract or waiver of any default of Contractor and making of any such payment by County while any such default or breach shall exist shall in no way impair or prejudice right of County with respect to recovery of damages or other remedy as result of such breach or default.
- B. Contractor shall remedy and make good all defective workmanship and materials and pay for any damage to other work resulting there from, which appear within period of one (1) year from date of substantial completion, providing such defects are not clearly due to abuse or misuse by County. Department will give notice of observed defects with reasonable promptness.
- C. Guarantee on work executed after certified date of substantial completion will begin on date when such work is inspected and approved by Architect / Engineer and Public Works Project Manager.
- D. Where guarantees or warranties are required in sections of Specifications for periods in excess of one (1) year, such longer terms shall apply; however, Contractor's Performance and Payment Bonds shall not apply to any guarantee or warranty period in excess of one (1) year.

40. CONFLICTING CONDITIONS

- A. Any provision in any of Construction Documents which may be in conflict or inconsistent with any Articles in these General Conditions of Contract or Supplementary Conditions shall be void to extent of such conflict or inconsistency.
- B. In case of ambiguity or conflict between Drawings and Specifications, Specifications shall govern.

- C. Printed dimensions shall be followed in preference to measurements by scale. Large-scale drawings take precedence over small-scale drawings. Dimensions on Drawings and details are subject to field measurements of adjacent work.

41. NOTICE AND SERVICE THEREOF

- A. Any notice to Contractor from Department relative to any part of this Contract shall be in writing and considered delivered and service thereof completed, when said notice is posted, by certified or registered mail, to Contractor at Contractor's last given address, or delivered in person to said Contractor, or Contractor's authorized representative on the Work.

42. PROTECTION OF LIVES AND HEALTH

- A. In order to protect lives and health of Contractor's employees under Contract, Contractor shall comply with all pertinent provisions of Wisconsin Administrative Code, Rules of Department of Commerce, relating to Safety and Health.
- B. Contractor alone shall be responsible for safety, efficiency and adequacy of Contractor's tools, equipment and methods, and for any damage that may result from their failure or their improper construction, maintenance or operation.

43. AFFIRMATIVE ACTION PROVISION AND MINORITY / WOMEN / DISADVANTAGED BUSINESS ENTERPRISES

- A. Affirmative Action Provisions.
 - 1. During term of their Contract, Contractor agrees not to discriminate on basis of race, religion, color, sex, handicap, age, sexual preference, marital status, physical appearance, or national origin against any person, whether recipient of services (actual or potential), employee, or applicant for employment. Such equal opportunity shall include but not be limited to following: employment, upgrading, demotion, transfer, recruitment, advertising, layoff, termination, training, rates of pay, and any other form of compensation or level of service(s). Contractor agrees to post in conspicuous places, these affirmative action standards so as to be visible to all employees, service recipients and applicants for this paragraph. Listing of prohibited bases for discrimination shall not be construed to amend in any fashion state or federal law setting forth additional bases and exceptions shall be permitted only to extent allowable in state or federal law.
 - 2. Contractor is subject to this Article only if Contractor has ten (10) or more employees and receives \$10,000.00 or more in annual aggregate contracts with County. Contractor shall file and Affirmative Action Plan with Dane County Contract Compliance Officer in accord with Chapter 19 of Dane County Code of Ordinances. Such plan must be filed within fifteen (15) business days of effective date of this Contract and failure to do so by said date shall constitute ground for immediate termination of Contract by County. Contractor shall also, during term of this Contract, provide copies of all announcements of employment opportunities to County's Contract Compliance Office, and shall report annually number of persons, by race, sex and handicap status, who apply for employment, and, similarly classified, number hired and number rejected.
 - 3. Contact Dane County Contract Compliance Officer at Dane County Contract Compliance Office, 210 Martin Luther King, Jr. Blvd., Room 421, Madison, WI 53703, 608/266-4114.
 - 4. In all solicitations for employment placed on Contractor's behalf during term of this Contract, Contractor shall include statement to affect Contractor is "Equal Opportunity Employer". Contractor agrees to furnish all information and reports required by

County's Contract Compliance Officer as same relate to affirmative action and nondiscrimination, which may include any books, records, or accounts deemed appropriate to determine compliance with Chapter 19, Dane County Code of Ordinances, and provision of this Contract.

- B. Minority / Women / Disadvantaged / Emerging Small Business Enterprises.
 - 1. Chapter 19.508 of Dane County Code of Ordinances is official policy of Dane County regarding utilization of, to fullest extent of, Minority Business Enterprises (MBEs), Women Business Enterprises (WBEs) Disadvantage Business Enterprises (DBEs) and Emerging Small Business Enterprises (ESBEs).
 - 2. Contractor may utilize MBEs / WBEs / DBEs / ESBEs as subcontractors or suppliers. List of subcontractors will be required of low bidder as stated in this Contract. List shall indicate which are MBEs / WBEs / DBEs / ESBEs and percentage of subcontract awarded, shown as percentage of total dollar amount of bid.

44. COMPLIANCE WITH FAIR LABOR STANDARDS

- A. During term of this Contract, Contractor shall report to County Contract Compliance Officer, within ten (10) business days, any allegations to, or findings by National Labor Relations Board (NLRB) or Wisconsin Employment Relations Commission (WERC) that Contractor has violated statute or regulation regarding labor standards or relations. If investigation by Contract Compliance Officer results in final determination that matter adversely affects Contractor's responsibilities under this Contract, and which recommends termination, suspension or cancellation of this Contract, County may take such action.
- B. Contractor may appeal any adverse finding by Contract Compliance Officer as set forth in Dane County Ordinance 25.015(11)(c) through (e).
- C. Contractor shall post this statement in prominent place visible to employees: "As condition of receiving and maintaining contract with Dane County, this employer shall comply with federal, state and all other applicable laws prohibiting retaliation or union organizing."

45. DOMESTIC PARTNERSHIP BENEFITS

- A. Contractor agrees to provide same economic benefits to all of its employees with domestic partners as it does to employees with spouses, or cash equivalent if such benefit cannot reasonably be provided. Contractor agrees to make available for County inspection Contractor's payroll records relating to employees providing services on or under this Contract or subcontract. If any payroll records of Contractor contain any false, misleading or fraudulent information, or if Contractor fails to comply with provisions of Chapter 25.016, Dane County Ordinances, contract compliance officer may withhold payments on Contract; terminate, cancel or suspend Contract in whole or in part; or, after due process hearing, deny Contractor right to participate in bidding on future County contracts for period of one year after first violation is found and for period of three years after second or subsequent violation is found.

46. USE AND OCCUPANCY PRIOR TO ACCEPTANCE

- A. Contractor agrees to use and occupancy of portion or unit of the Work before formal acceptance by Department, provided Department:

1. Secures written consent of Contractor; except when in opinion of Public Works Project Manager, Contractor is chargeable with unwarranted delay in final cleanup of punch list items or other Contract requirements.
2. Secures endorsement from insurance carrier and consent of Surety permitting occupancy of building or use of the Work during remaining period of construction, or, secures consent of Surety.
3. Assumes all costs and maintenance of heat, electricity and water.
4. Accepts all work completed within that portion or unit of the Work to be occupied, at time of occupancy.

47. MINIMUM WAGES

- A. Contractor shall post, at appropriate conspicuous point on site of project, schedule showing all determined minimum wage rates for various classes of laborers and mechanics to be engaged in the Work under this Contract and all deductions, if any, required by law to be made from unpaid wages actually earned by laborers and mechanics so engaged.
- B. Supplementary Conditions section in Construction Documents lists wage determinations required by State Law.
- C. If, after award of Contract, it becomes necessary to employ any person in trade or occupation not classified in wage determinations, such person shall be paid at not less than such rate as shall be determined by Wisconsin Department of Workforce Development. Such approved minimum rate shall be retroactive to time of initial employment of such person in such trade or occupation. Contractor shall notify Department of Contractor's intention to employ persons in trades or occupations not so classified in sufficient time for Department to obtain approved rates for such trades or occupations.
- D. Specified wage rates are minimum rates only, and Department will not consider any claims for additional compensation made by Contractor because of payment by Contractor of any wage rate in excess of applicable rate contained in this Contract. Contractor shall adjust any disputes in regard to payment of wages in excess of those specified in this Contract.
- E. Submit required affidavit(s) to Department of Public Works, Highway & Transportation, as requested and with final application for payment for work under said contract. Affidavit(s) shall clearly indicate name, trade or occupation, and paid wages of every laborer, worker or mechanic employed by Contractor and all subcontractors during billing period including accurate record of number of hours worked by each employee and actual wages paid as stipulated in Wisconsin Statute 66.0903. If Wisconsin Prevailing Wage Rate Determination is required for this Work, use "Prime Contractor Affidavit of Compliance with Prevailing Wage Rate Determination" and "Agent or Subcontractor Affidavit of Compliance with Prevailing Wage Rate Determination" (if applicable). If Wisconsin Prevailing Wage Rate Determination is not required for this Work, use "Dane County, Wisconsin Contractor Wage Affidavit". Forms of such affidavits are included in Supplementary Conditions.

48. CLAIMS

- A. No claim may be made until Department's Assistant Public Works Director has reviewed Architect / Engineer's decision as provided for in Article 35 of General Conditions of Contract. If any claim remains unresolved after such review by Department's Assistant Public Works Director the claim may be filed under Wisconsin Statute 893.80. Work shall progress during period of any dispute or claim. Unless specifically agreed between parties, venue will be in Dane County, Wisconsin.

49. ANTITRUST AGREEMENT

- A. Contractor and County recognize that in actual economic practice, overcharges resulting from antitrust violations are in fact usually borne by County. Therefore, Contractor hereby assigns to County any and all claims for such overcharges as to goods and materials purchased in connection with this Contract, except as to overcharges which result from antitrust violations commencing after price is established under this Contract and any change order thereto.

50. INSURANCE

A. Contractor Carried Insurance:

1. Contractor shall not commence work under this Contract until Contractor has obtained all insurance required under this Article and has provided evidence of such insurance to Risk Manager, 425 City-County Building, 210 Martin Luther King Jr. Blvd., Madison, WI 53703. Contractor shall not allow any subcontractor to commence work until insurance required of subcontractor has been so obtained and approved. Company providing insurance must be licensed to do business in Wisconsin.
2. Worker's Compensation Insurance:
 - a) Contractor shall procure and shall maintain during life of this Contract, Worker's Compensation Insurance as required by statute for all of Contractor's employees engaged in work at site of project under this Contract and, in case of any such work sublet, Contractor shall require subcontractor similarly to provide Worker's Compensation Insurance for all of latter's employees to be engaged in such work unless such employees are covered by protection afforded by Contractor's Worker's Compensation Insurance.
 - b) If any claim of employees engaged in hazardous work on project under this Contract is not protected under Worker's Compensation Statute, Contractor shall provide and shall cause each subcontractor to provide adequate Employer's Liability Insurance for protection of such of Contractor's employees as are not otherwise protected.
3. Contractor's Public Liability and Property Damage Insurance:
 - a) Contractor shall procure and maintain during life of this Contract, Contractor's Public Liability Insurance and Contractor's Property Damage Insurance in amount not less than \$1,000,000 bodily injury, including accidental death, to any one person, and subject to same limit for each person, in amount not less than \$1,000,000 on account of one accident, and Contractor's Property Damage Insurance in amount not less than \$1,000,000 or combined single limit of at least \$1,000,000 with excess coverage over and above general liability in amount not less than \$5,000,000. Contractor shall add "Dane County" as additional insured for each project.
 - b) Contractor's Public Liability and Property Damage Insurance shall include Products, Completed Operation, and Contractual Liability under Insurance Contract. "Contractor shall in all instances save, defend, indemnify and hold harmless County and Architect / Engineer against all claims, demands, liabilities, damages or any other costs which may accrue in prosecution of the Work and that Contractor will save, defend, indemnify and hold harmless County and Architect / Engineer from all damages caused by or as result of Contractor's operations" and each shall be listed as additional insured on Contractor's and sub-contractors' insurance policies.
 - c) Obligations of Contractor under Article 50.A.2.b) shall not extend to liability of Architect / Engineer, agents or employees thereof, arising out of:
 - 1) Preparation or approval of maps, drawings, opinions, reports, surveys, change orders, designs or specifications; or

- 2) Giving of or failure to give directions or instructions by Architect / Engineer, agents or employees thereof provided such giving or failure to give is primary cause of injury or damage.
- d) Contractor shall procure and shall maintain during life of this Contract, Comprehensive Automobile Liability Insurance covering owned, non-owned and hired automobiles for limits of not less than \$1,000,000 each accident single limit, bodily injury and property damage combined with excess coverage over and above general liability in amount not less than \$5,000,000.
- e) Contractor shall either:
 - 1) Require each subcontractor to procure and to maintain during life of subcontract, subcontractor's Public Liability Property Damage Insurance, and Comprehensive Automobile Liability Insurance of type and in same amount specified in preceding paragraphs; or
 - 2) Insure activities of subcontractors in Contractor's own policy.
- 4. Scope of Insurance and Special Hazards: Insurance required under Article 50.A.2 & 50.A.3. hereof shall provide adequate protection for Contractor and subcontractors, respectively, against damage claims which may arise from operations under this Contract, whether such operation be by insured or by anyone directly or indirectly employed by insured and also against any of special hazards which may be encountered in performance of this Contract as enumerated in Supplementary Conditions.
- 5. Proof of Carriage of Insurance: Contractor shall furnish Risk Manager with certificates showing type, amount, class of operations covered, effective dates, dates of expiration of policies and "Dane County" listed as additional insured. Such certificates shall also contain (substantially) following statement: "Insurance covered by this certificate will not be canceled or materially altered, except after ten (10) business days written notice has been received by Risk Manager."

B. Builder's Risk:

- 1. County shall provide Builder's Risk policy. Terms of this policy will be made available by County's Risk Manager, upon Contractor's request. By executing this Contract, Contractor warrants it is familiar with terms of said policy.

C. Indemnification / Hold Harmless:

- 1. Contractor shall indemnify, hold harmless and defend Dane County, its boards, commissions, agencies, officers, employees and representatives from and against all claims, damages, losses and expenses including attorneys' fees arising out of or resulting from performance of the Work, provided that any such claim, damage, loss or expense is attributable to bodily injury, sickness, disease or death, or to injury to or destruction of tangible property (other than the Work itself) including loss of use resulting therefrom, and is caused in whole or in part by any act or omission of Contractor, any subcontractor, anyone directly or indirectly employed by any of them or anyone for whose acts any of them may be liable, regardless of whether or not it is caused in part by part indemnified hereunder.
- 2. In any and all claims against Dane County, its boards, commissions, agencies, officers, employees and representatives or by any employee of Contractor, any subcontractor, anyone directly or indirectly employed by any of them or anyone for whose acts any of them may be liable, indemnification obligation under this Contract shall not be limited in any way by any limitation on amount or type of damages, compensation or benefits payable by or for Contractor or any subcontractor under worker's compensation acts, disability benefits or other employee benefit acts.
- 3. Obligations of Contractor under this Contract shall not extend to liability of Architect / Engineer, its agents or employees arising out of:
 - a) Preparation or approval of maps, drawings, opinion, reports, surveys, change orders, designs or specifications; or

- b) Giving of or failure to give directions or instruction by Architect / Engineer, its agents or employees provided such giving or failure to give is primary cause of injury or damage.
- 4. Dane County shall not be liable to Contractor for damages or delays resulting from work by third parties or by injunctions or other restraining orders obtained by third parties.

51. WISCONSIN LAW CONTROLLING

- A. It is expressly understood and agreed to by parties hereto that in event of any disagreement or controversy between parties, Wisconsin law shall be controlling.

SUPPLEMENTARY CONDITIONS

1. APPLICATION & CERTIFICATE FOR PAYMENT

- A. Every contractor engaged in performance of any contract for Department of Public Works, Highway & Transportation shall submit partial and final Application & Certificate for Payment for work under said contract. Form shall provide similar information as shown on AIA G702™ and G703™ forms (samples shown below). Forms shall be submitted to the Public Works Project Manager for approval.

AIA Document G702™ – 1992

Application and Certificate for Payment

TO OWNER:	PROJECT:	APPLICATION NO:	Distribution to:
		PERIOD TO:	OWNER <input type="checkbox"/>
FROM CONTRACTOR:	VIA ARCHITECT:	CONTRACT FOR:	ARCHITECT <input type="checkbox"/>
		CONTRACT DATE:	CONTRACTOR <input type="checkbox"/>
		PROJECT NOS:	FIELD <input type="checkbox"/>
			OTHER <input type="checkbox"/>

CONTRACTOR'S APPLICATION FOR PAYMENT

Application is made for payment, as shown below, in connection with the Contract. AIA Document G703™, Continuation Sheet, is attached.

1. ORIGINAL CONTRACT SUM	\$
2. NET CHANGE BY CHANGE ORDERS	\$
3. CONTRACT SUM TO DATE (Line 1 + 2)	\$
4. TOTAL COMPLETED & STORED TO DATE (Column G on G703)	\$
5. RETAINAGE:	
a. % of Completed Work (Column D + E on G703)	\$
b. % of Stored Material (Column F on G703)	\$
Total Retainage (Lines 5a + 5b, or Total in Column I of G703)	\$
6. TOTAL EARNED LESS RETAINAGE	\$
(Line 4 minus Line 5 Total)	
7. LESS PREVIOUS CERTIFICATES FOR PAYMENT	\$
(Line 6 from prior Certificate)	
8. CURRENT PAYMENT DUE	\$
9. BALANCE TO FINISH, INCLUDING RETAINAGE	\$
(Line 3 minus Line 6)	

CHANGE ORDER SUMMARY	ADDITIONS	DEDUCTIONS
Total changes approved in previous months by Owner	\$	\$
Total approved this month	\$	\$
TOTAL	\$	\$
NET CHANGES by Change Order	\$	\$

CAUTION: You should sign an original AIA Contract Document, on which this text appears in RED. An original assures that changes will not be obscured.

AIA Document G702™ – 1992. Copyright © 1953, 1963, 1965, 1971, 1978, 1983 and 1992 by The American Institute of Architects. All rights reserved. **WARNING:** This AIA® Document is protected by U.S. Copyright Law and International Treaties. Unauthorized reproduction or distribution of this AIA® Document, or any portion of it, may result in severe civil and criminal penalties, and will be prosecuted to the maximum extent possible under the law. Purchasers are permitted to reproduce ten (10) copies of this document when completed. To report copyright violations of AIA Contract Documents, e-mail The American Institute of Architects' legal counsel, copyright@aia.org.

The undersigned Contractor certifies that to the best of the Contractor's knowledge, information and belief the Work covered by this Application for Payment has been completed in accordance with the Contract Documents, that all amounts have been paid by the Contractor for Work for which previous Certificates for Payment were issued and payments received from the Owner, and that current payment shown herein is now due.

CONTRACTOR:
 By: _____ Date: _____
 State of: _____
 Country of: _____
 Subscribed and sworn to before me this _____ day of _____
 Notary Public:
 My commission expires: _____

ARCHITECT'S CERTIFICATE FOR PAYMENT

In accordance with the Contract Documents, based on on-site observations and the data comprising this application, the Architect certifies to the Owner that to the best of the Architect's knowledge, information and belief the Work has progressed as indicated, the quality of the Work is in accordance with the Contract Documents, and the Contractor is entitled to payment of the AMOUNT CERTIFIED.

AMOUNT CERTIFIED \$ _____
 (Attach explanation if amount certified differs from the amount applied. Initial all figures on this Application and on the Continuation Sheet that are changed to conform with the amount certified.)

ARCHITECT:
 By: _____ Date: _____

This Certificate is not negotiable. The AMOUNT CERTIFIED is payable only to the Contractor named herein. Issuance, payment and acceptance of payment are without prejudice to any rights of the Owner or Contractor under this Contract.

AIA Document G703™ – 1992

Continuation Sheet

AIA Document G702™-1992, Application and Certificate for Payment, or G732™-2009, Application and Certificate for Payment, Construction Manager as Adviser Edition, containing Contractor's signed certification is attached. In tabulations below, amounts are in US dollars. Use Column I on Contracts where variable retainage for line items may apply.

APPLICATION NO:
 APPLICATION DATE:
 PERIOD TO:
 ARCHITECT'S PROJECT NO:

A ITEM NO.	B DESCRIPTION OF WORK	C SCHEDULED VALUE	D WORK COMPLETED		F MATERIALS PRESENTLY STORED (Not in D or E)	G TOTAL COMPLETED AND STORED TO DATE (D+E+F)	H BALANCE TO FINISH (C-G)	I RETAINAGE (if variable rate)
			FROM PREVIOUS APPLICATION (D - E)	THIS PERIOD				
GRAND TOTAL								

CAUTION: You should sign an original AIA Contract Document, on which this text appears in RED. An original assures that changes will not be obscured.

AIA Document G703™ – 1992. Copyright © 1963, 1965, 1966, 1967, 1970, 1978, 1983 and 1992 by The American Institute of Architects. All rights reserved. **WARNING:** This AIA® Document is protected by U.S. Copyright Law and International Treaties. Unauthorized reproduction or distribution of this AIA® Document, or any portion of it, may result in severe civil and criminal penalties, and will be prosecuted to the maximum extent possible under the law. Purchasers are permitted to reproduce ten (10) copies of this document when completed. To report copyright violations of AIA Contract Documents, e-mail The American Institute of Architects' legal counsel, copyright@aia.org.

2. PREVAILING WAGE RATE DETERMINATION

- A. These supplements shall modify, delete, and / or add to General Conditions of Contract. Where any article, paragraph, or subparagraph in General Conditions of Contract is supplemented by one of these paragraphs, provisions of such article, paragraph, or subparagraph shall remain in effect and supplementary provisions shall be considered as added thereto. Where any article, paragraph, or subparagraph in General Conditions of Contract is amended, voided, or superseded by any of these paragraphs, provisions of such article, paragraph, or subparagraph not so amended, voided, or superseded shall remain in effect.
 - 1. General Conditions of Contract Article 47, “Minimum Wages”, paragraph B. Following Prevailing Wage Rate Determination No.201600346 is added to General Conditions of Contract.

- B. These State of Wisconsin forms, hereinafter set forth in this section, shall be filled out and submitted to Department of Public Works, Highway & Transportation:
 - 1. Disclosure of Ownership (ERD-7777)
 - 2. Prime Contractor Affidavit of Compliance With Prevailing Wage Rate Determination (ERD-5724)
 - 3. List of Agents and Subcontractors (Page 2 - ERD-5724)
 - 4. Agent or Subcontractor Affidavit of Compliance With Prevailing Wage Rate Determination (ERD-10584)
 - 5. List of Agents and Subcontractors (Page 2 - ERD-10584)
 - 6. Request To Employ Subjourneyperson (ERD-10880)

- C. At a minimum, these wage rates must be displayed in a place where all workers can access them, but not inside the job trailer. If this isn’t easily done based on job conditions, the State requires they be displayed at a library or other public building.

THIS PAGE INTENTIONALLY LEFT BLANK

State of Wisconsin Department of Workforce Development Equal Rights Division	DEPARTMENTAL ORDER
ISSUE DATE: 2/1/2016	
PROJECT:	
COLISEUM LOADING DOCKS ALLIANT ENERGY CENTER MADISON TOWN, DANE COUNTY, WI Determination No. 201600346 [Owner Project No. 316001]	
PROJECT OWNER:	REQUESTER:
ERIC URTES, PROJECT MANAGER DANE COUNTY PUBLIC WORKS 1919 ALLIANT ENERGY CENTER WAY MADISON, WI 53713	ERIC URTES, PROJECT MANAGER DANE COUNTY PUBLIC WORKS 1919 ALLIANT ENERGY CENTER WAY MADISON, WI 53713
ADDITIONAL CONTACT:	NOTE: The Requester must provide a copy of this Project Determination and enclosures to the Project Owner and Additional Contact.
<p>The department received an application for prevailing wage rate determination for the above-captioned project. The department conducted a survey to determine the prevailing wage rate for the trade(s) or occupation(s) needed to complete the project. The survey's findings appear in the attached project determination.</p> <p>If you believe that the wage rate for any trade or occupation does not accurately reflect the prevailing wage rate in the city, village or town where the project is located, you may ask the department to conduct an administrative review of such wage rate. You must submit this request in writing within 30 days from the date indicated above. Additionally, your request must include wage rate information from at least three similar projects in the city, village or town where the proposed project is located and on which some work has been performed by the contested trade(s) during the current survey period and was previously considered by the department in issuing the attached determination. See DWD 290.10 of the Wisconsin Administrative Code and either s. 66.0903(3)(br), Stats., or s. 103.49(3)(c), Stats., for a complete explanation of the administrative review process.</p> <p>Enclosures</p>	
<p>It is hereby ordered that the prevailing wage rates set forth in the attached project determination shall only be applicable to the above referenced project. This order is a FINAL ORDER of the department unless a timely request for an administrative review is filed with the department.</p> <p>ISSUED BY:</p> <p style="text-align: center;"> Equal Rights Division Labor Standards Bureau Construction Wage Standards Section P.O. Box 8928, Madison, WI 53708-8928 (608)266-6861 </p> <p style="text-align: center;"> Web Site: http://dwd.wisconsin.gov/er/ </p>	

PREVAILING WAGE RATE DETERMINATION

Issued by the State of Wisconsin
Department of Workforce Development
Pursuant to s. 66.0903, Wis. Stats.
Issued On: 2/1/2016

DETERMINATION NUMBER: 201600346

EXPIRATION DATE: Prime Contracts MUST Be Awarded or Negotiated On Or Before 12/31/2016. If NOT, You MUST Reapply.

PROJECT NAME: COLISEUM LOADING DOCKS ALLIANT ENERGY CENTER
PROJECT NO: 316001

PROJECT LOCATION: MADISON TOWN, DANE COUNTY, WI

CONTRACTING AGENCY: DANE COUNTY PUBLIC WORKS

CLASSIFICATION:	Contractors are responsible for correctly classifying their workers. Either call the Department of Workforce Development (DWD) with trade or classification questions or consult DWD's Dictionary of Occupational Classifications & Work Descriptions on the DWD website at: dwd.wisconsin.gov/er/prevailing_wage_rate/Dictionary/dictionary_main.htm .
OVERTIME:	Time and one-half must be paid for all hours worked: <ul style="list-style-type: none">- over 10 hours per day on prevailing wage projects- over 40 hours per calendar week- Saturday and Sunday- on all of the following holidays: January 1; the last Monday in May; July 4; the 1st Monday in September; the 4th Thursday in November; December 25;- The day before if January 1, July 4 or December 25 falls on a Saturday;- The day following if January 1, July 4 or December 25 falls on a Sunday. Apply the time and one-half overtime calculation to whichever is higher between the Hourly Basic Rate listed on this project determination or the employee's regular hourly rate of pay. Add any applicable Premium or DOT Premium to the Hourly Basic Rate before calculating overtime. A DOT Premium (discussed below) may supersede this time and one-half requirement.
FUTURE INCREASE:	When a specific trade or occupation requires a future increase, you MUST add the full hourly increase to the "TOTAL" on the effective date(s) indicated for the specific trade or occupation.
PREMIUM PAY:	If indicated for a specific trade or occupation, the full amount of such pay MUST be added to the "HOURLY BASIC RATE OF PAY" indicated for such trade or occupation, whenever such pay is applicable.
DOT PREMIUM:	This premium only applies to highway and bridge projects owned by the Wisconsin Department of Transportation and to the project type heading "Airport Pavement or State Highway Construction." DO NOT apply the premium calculation under any other project type on this determination.
APPRENTICES:	Pay apprentices a percentage of the applicable journey person's hourly basic rate of pay and hourly fringe benefit contributions specified in this determination. Obtain the appropriate percentage from each apprentice's contract or indenture.
SUBJOURNEY:	Subjourney wage rates may be available for some of the trades or occupations indicated below with the exception of laborers, truck drivers and heavy equipment operators. Any employer interested in using a subjourney classification on this project MUST complete Form ERD-10880 and request the applicable wage rate from the Department of Workforce Development PRIOR to using the subjourney worker on this project.

This document **MUST BE POSTED** by the **CONTRACTING AGENCY** in at least one conspicuous and easily accessible place **on the site of the project**. A local governmental unit may post this document at the place normally used to post public notices if there is no common site on the project. This document **MUST** remain posted during the entire time any worker is employed on the project and **MUST** be physically incorporated into the specifications and all contracts and subcontracts. If you have any questions, please write to the Equal Rights Division, Labor Standards Bureau, P.O. Box 8928, Madison, Wisconsin 53708 or call (608) 266-6861.

The following statutory provisions apply to local governmental unit projects of public works and are set forth below pursuant to the requirements of s. 66.0903(8), Stats.

s. 66.0903 (1) (f) & s. 103.49 (1) (c) "PREVAILING HOURS OF LABOR" for any trade or occupation in any area means 10 hours per day and 40 hours per week and may not include any hours worked on a Saturday or Sunday or on any of the following holidays:

1. January 1.
2. The last Monday in May.
3. July 4.
4. The first Monday in September.
5. The 4th Thursday in November.
6. December 25.
7. The day before if January 1, July 4 or December 25 falls on a Saturday.
8. The day following if January 1, July 4 or December 25 falls on a Sunday.

s. 66.0903 (10) RECORDS; INSPECTION; ENFORCEMENT.

(a) Each contractor, subcontractor, or contractor's or subcontractor's agent performing work on a project of public works that is subject to this section shall keep full and accurate records clearly indicating the name and trade or occupation of every person performing the work described in sub. (4) and an accurate record of the number of hours worked by each of those persons and the actual wages paid for the hours worked.

s. 66.0903 (11) LIABILITY AND PENALTIES.

(a) 1. Any contractor, subcontractor, or contractor's or subcontractor's agent who fails to pay the prevailing wage rate determined by the department under sub. (3) or who pays less than 1.5 times the hourly basic rate of pay for all hours worked in excess of the prevailing hours of labor is liable to any affected employee in the amount of his or her unpaid wages or his or her unpaid overtime compensation and in an additional amount as liquidated damages as provided under subd. 2., 3., whichever is applicable.

2. If the department determines upon inspection under sub. (10) (b) or (c) that a contractor, subcontractor, or contractor's or subcontractor's agent has failed to pay the prevailing wage rate determined by the department under sub. (3) or has paid less than 1.5 times the hourly basic rate of pay for all hours worked in excess of the prevailing hours of labor, the department shall order the contractor to pay to any affected employee the amount of his or her unpaid wages or his or her unpaid overtime compensation and an additional amount equal to 100 percent of the amount of those unpaid wages or that unpaid overtime compensation as liquidated damages within a period specified by the department in the order.

3. In addition to or in lieu of recovering the liability specified in subd. 1. as provided in subd. 2., any employee for and in behalf of that employee and other employees similarly situated may commence an action to recover that liability in any court of competent jurisdiction. If the court finds that a contractor, subcontractor, or contractor's or subcontractor's agent has failed to pay the prevailing wage rate determined by the department under sub. (3) or has paid less than 1.5 times the hourly basic rate of pay for all hours worked in excess of the prevailing hours of labor, the court shall order the contractor, subcontractor, or agent to pay to any affected employee the amount of his or her unpaid wages or his or her unpaid overtime compensation and an additional amount equal to 100 percent of the amount of those unpaid wages or that unpaid overtime compensation as liquidated damages.

5. No employee may be a party plaintiff to an action under subd. 3. unless the employee consents in writing to become a party and the consent is filed in the court in which the action is brought. Notwithstanding s. 814.04 (1), the court shall, in addition to any judgment awarded to the plaintiff, allow reasonable attorney fees and costs to be paid by the defendant.

BUILDING OR HEAVY CONSTRUCTION

Includes sheltered enclosures with walk-in access for the purpose of housing persons, employees, machinery, equipment or supplies and non-sheltered work such as canals, dams, dikes, reservoirs, storage tanks, etc. A sheltered enclosure need not be "habitable" in order to be considered a building. The installation of machinery and/or equipment, both above and below grade level, does not change a project's character as a building. On-site grading, utility work and landscaping are included within this definition. Residential buildings of four (4) stories or less, agricultural buildings, parking lots and driveways are NOT included within this definition.

SKILLED TRADES

Fringe Benefits Must Be Paid On <u>All</u> Hours Worked		HOURLY BASIC RATE OF PAY	HOURLY FRINGE BENEFITS	TOTAL
CODE	TRADE OR OCCUPATION	\$	\$	\$
101	Acoustic Ceiling Tile Installer Future Increase(s): Add \$1.42/hr on 6/1/2016.	33.02	17.12	50.14
102	Boilermaker	33.35	28.29	61.64
103	Bricklayer, Blocklayer or Stonemason Future Increase(s): Add \$1.45 on 06/06/2016 Premium Increase(s): DOT PREMIUM: Pay two times the hourly basic rate on Sunday, New Year's Day, Memorial Day, Independence Day, Labor Day, Thanksgiving Day & Christmas Day.	32.86	20.03	52.89
104	Cabinet Installer Future Increase(s): Add \$1.42/hr on 6/1/2016.	33.02	17.12	50.14
105	Carpenter Future Increase(s): Add \$1.42/hr on 6/1/2016. Premium Increase(s): DOT PREMIUM: Pay two times the hourly basic rate on Sunday, New Year's Day, Memorial Day, Independence Day, Labor Day, Thanksgiving Day & Christmas Day.	33.02	17.12	50.14
106	Carpet Layer or Soft Floor Coverer Future Increase(s): Add \$1.42/hr on 6/1/2016.	33.02	17.12	50.14
107	Cement Finisher	33.15	16.40	49.55
108	Drywall Taper or Finisher	29.97	20.08	50.05
109	Electrician Future Increase(s): Add \$1.25/hr on 6/1/16. Premium Increase(s): DOT PREMIUM: Pay two times the hourly basic rate on Sunday, New Year's Day, Memorial Day, Independence Day, Labor Day, Thanksgiving Day & Christmas Day.	35.75	19.97	55.72
110	Elevator Constructor	46.05	27.09	73.14
111	Fence Erector	18.72	5.78	24.50

Fringe Benefits Must Be Paid On <u>All</u> Hours Worked		HOURLY BASIC RATE OF PAY	HOURLY FRINGE BENEFITS	TOTAL
CODE	TRADE OR OCCUPATION	\$	\$	\$
112	Fire Sprinkler Fitter	36.78	19.97	56.75
113	Glazier	38.27	14.42	52.69
114	Heat or Frost Insulator	33.53	27.31	60.84
115	Insulator (Batt or Blown) Future Increase(s): Add \$1.42/hr on 6/1/2016.	33.02	17.12	50.14
116	Ironworker	32.50	20.58	53.08
117	Lather	32.72	16.00	48.72
118	Line Constructor (Electrical)	40.81	18.06	58.87
119	Marble Finisher	25.72	18.54	44.26
120	Marble Mason	32.82	18.67	51.49
121	Metal Building Erector	22.40	6.27	28.67
122	Millwright Future Increase(s): Add \$1.47/hr on 6/1/2016.	34.79	17.17	51.96
123	Overhead Door Installer	31.93	13.39	45.32
124	Painter	26.70	16.65	43.35
125	Pavement Marking Operator	30.00	18.81	48.81
126	Piledriver Future Increase(s): Add \$1.44/hr on 6/1/2016. Premium Increase(s): DOT PREMIUM: Pay two times the hourly basic rate on Sunday, New Year's Day, Memorial Day, Independence Day, Labor Day, Thanksgiving Day & Christmas Day.	33.56	17.12	50.68
127	Pipeline Fuser or Welder (Gas or Utility)	44.20	18.26	62.46
129	Plasterer	32.82	18.81	51.63
130	Plumber	38.82	18.02	56.84
132	Refrigeration Mechanic	45.55	18.71	64.26
133	Roofer or Waterproofer	29.65	1.71	31.36
134	Sheet Metal Worker	35.55	24.67	60.22
135	Steamfitter	45.55	18.71	64.26
137	Teledata Technician or Installer	22.50	12.74	35.24
138	Temperature Control Installer	34.97	19.67	54.64
139	Terrazzo Finisher	25.72	18.54	44.26

Fringe Benefits Must Be Paid On <u>All</u> Hours Worked		HOURLY BASIC RATE OF PAY	HOURLY FRINGE BENEFITS	TOTAL
CODE	TRADE OR OCCUPATION	\$	\$	\$
140	Terrazzo Mechanic Future Increase(s): Add \$1.60 on 06/06/2016	33.98	18.96	52.94
141	Tile Finisher	30.00	0.00	30.00
142	Tile Setter Future Increase(s): Add \$1.45/hr on 6/06/2016.	31.59	19.61	51.20
143	Tuckpointer, Caulker or Cleaner Future Increase(s): Add \$1.45 on 06/06/2016 Premium Increase(s): DOT PREMIUM: Pay two times the hourly basic rate on Sunday, New Year's Day, Memorial Day, Independence Day, Labor Day, Thanksgiving Day & Christmas Day.	32.86	20.03	52.89
144	Underwater Diver (Except on Great Lakes)	36.74	16.00	52.74
146	Well Driller or Pump Installer Future Increase(s): Add \$1/hr on 6/1/2016; Add \$1/hr on 6/1/2017.	25.32	16.40	41.72
147	Siding Installer	17.00	6.71	23.71
150	Heavy Equipment Operator - ELECTRICAL LINE CONSTRUCTION ONLY	36.73	20.41	57.14
151	Light Equipment Operator -ELECTRICAL LINE CONSTRUCTION ONLY	32.65	15.52	48.17
152	Heavy Truck Driver - ELECTRICAL LINE CONSTRUCTION ONLY	28.57	13.71	42.28
153	Light Truck Driver - ELECTRICAL LINE CONSTRUCTION ONLY	26.53	13.55	40.08
154	Groundman - ELECTRICAL LINE CONSTRUCTION ONLY	25.00	12.55	37.55

TRUCK DRIVERS

Fringe Benefits Must Be Paid On <u>All</u> Hours Worked		HOURLY BASIC RATE OF PAY	HOURLY FRINGE BENEFITS	TOTAL
CODE	TRADE OR OCCUPATION	\$	\$	\$
201	Single Axle or Two Axle	33.69	19.78	53.47
203	Three or More Axle	18.25	21.61	39.86
204	Articulated, Euclid, Dumptor, Off Road Material Hauler Future Increase(s): Add \$1.60/hr on 6/3/2016.	34.69	20.38	55.07
205	Pavement Marking Vehicle	18.25	21.61	39.86
207	Truck Mechanic	18.25	21.61	39.86

LABORERS

Fringe Benefits Must Be Paid On <u>All</u> Hours Worked		HOURLY BASIC RATE OF PAY	HOURLY FRINGE BENEFITS	TOTAL
CODE	TRADE OR OCCUPATION	\$	\$	\$
301	General Laborer Future Increase(s): Add \$1.25/hr eff. 06/06/2016 Premium Increase(s): Add \$1.00/hr for certified welder and pipelayer; Add \$.25/hr for mason tender.	25.81	15.63	41.44
302	Asbestos Abatement Worker	17.00	4.22	21.22
303	Landscaper	21.90	9.83	31.73
310	Gas or Utility Pipeline Laborer (Other Than Sewer and Water)	20.83	18.39	39.22
311	Fiber Optic Laborer (Outside, Other Than Concrete Encased)	19.35	0.00	19.35
314	Railroad Track Laborer	17.00	3.96	20.96
315	Final Construction Clean-Up Worker	29.01	7.20	36.21

**HEAVY EQUIPMENT OPERATORS
SITE PREPARATION, UTILITY OR LANDSCAPING WORK ONLY**

Fringe Benefits Must Be Paid On <u>All</u> Hours Worked		HOURLY BASIC RATE OF PAY	HOURLY FRINGE BENEFITS	TOTAL
CODE	TRADE OR OCCUPATION	\$	\$	\$
501	Air Track, Rotary or Percussion Drilling Machine &/or Hammers, Blaster; Asphalt Milling Machine; Boring Machine (Directional, Horizontal or Vertical); Backhoe (Track Type) Having a Mfgr's Rated Capacity of 130,000 Lbs. or Over; Backhoe (Track Type) Having a Mfgr's Rated Capacity of Under 130,000 Lbs., Backhoe (Mini, 15,000 Lbs. & Under); Bulldozer or Endloader (Over 40 hp); Compactor (Self-Propelled 85 Ft Total Drum Width & Over, or Tractor Mounted, Towed & Light Equipment); Concrete Batch Plant, Batch Hopper; Concrete Breaker (Large, Auto, Vibratory/Sonic, Manual or Remote); Crane, Shovel, Dragline, Clamshells; Forklift (Machinery Moving or Steel Erection, 25 Ft & Over); Gradall (Cruz-Aire Type); Grader or Motor Patrol; Master Mechanic; Mechanic or Welder; Robotic Tool Carrier (With or Without Attachments); Scraper (Self Propelled or Tractor Drawn) 5 cu yds or More Capacity; Tractor or Truck Mounted Hydraulic Backhoe; Tractor or Truck Mounted Hydraulic Crane (10 Tons or Under); Tractor (Scraper, Dozer, Pusher, Loader); Trencher (Wheel Type or Chain Type Having Over 8 Inch Bucket). Future Increase(s): Add \$1.60/hr on 6/3/2016.	35.22	20.38	55.60
502	Backfiller; Broom or Sweeper; Bulldozer or Endloader (Under 40 hp); Environmental Burner; Forestry Equipment, Timbco, Tree Shear, Tub Grinder, Processor; Jeep Digger; Screed (Milling Machine); Skid Rig; Straddle Carrier or Travel Lift; Stump Chipper; Trencher (Wheel Type or Chain Type Having 8 Inch Bucket & Under). Future Increase(s): Add \$1.60/hr on 6/3/2016.	34.69	20.38	55.07

Fringe Benefits Must Be Paid On <u>All</u> Hours Worked				
CODE	TRADE OR OCCUPATION	HOURLY BASIC RATE OF PAY	HOURLY FRINGE BENEFITS	TOTAL
		\$	\$	\$
503	Air Compressor (&/or 400 CFM or Over); Augers (Vertical & Horizontal); Compactor (Self-Propelled 84 Ft Total Drum Width & Under, or Tractor Mounted, Towed & Light Equipment); Crusher, Screening or Wash Plant; Farm or Industrial Type Tractor; Forklift; Generator (&/or 150 KW or Over); Greaser; High Pressure Utility Locating Machine (Daylighting Machine); Mulcher; Oiler; Post Hole Digger or Driver; Pump (3 Inch or Over) or Well Points; Refrigeration Plant or Freeze Machine; Rock, Stone Breaker; Skid Steer Loader (With or Without Attachments); Vibratory Hammer or Extractor, Power Pack. Future Increase(s): Add \$1.60/hr on 6/3/2016.	32.62	20.38	53.00
504	Work Performed on the Great Lakes Including Diver; Wet Tender or Hydraulic Dredge Engineer.	41.65	21.71	63.36
505	Work Performed on the Great Lakes Including Crane or Backhoe Operator; Assistant Hydraulic Dredge Engineer; Hydraulic Dredge Leverman or Diver's Tender; Mechanic or Welder; 70 Ton & Over Tug Operator. Future Increase(s): Add \$1.25/hr on 1/1/2017. Premium Increase(s): Add \$.50/hr for Friction Crane, Lattice Boom or Crane Certification (CCO).	44.05	23.24	67.29
506	Work Performed on the Great Lakes Including Deck Equipment Operator or Machineryman (Maintains Cranes Over 50 Tons or Backhoes 115,000 Lbs. or More); Tug, Launch or Loader, Dozer or Like Equipment When Operated on a Barge, Breakwater Wall, Slip, Dock or Scow, Deck Machinery. Future Increase(s): Add \$1.25/hr on 1/1/2017.	39.20	23.09	62.29
507	Work Performed on the Great Lakes Including Deck Equipment Operator, Machineryman or Fireman (Operates 4 Units or More or Maintains Cranes 50 Tons or Under or Backhoes 115,000 Lbs. or Under); Deck Hand, Deck Engineer or Assistant Tug Operator; Off Road Trucks - Great Lakes ONLY.	36.72	21.15	57.87

**HEAVY EQUIPMENT OPERATORS
EXCLUDING SITE PREPARATION, UTILITY, PAVING LANDSCAPING WORK**

Fringe Benefits Must Be Paid On <u>All</u> Hours Worked				
CODE	TRADE OR OCCUPATION	HOURLY BASIC RATE OF PAY	HOURLY FRINGE BENEFITS	TOTAL
		\$	\$	\$
508	Boring Machine (Directional); Crane, Tower Crane, Pedestal Tower or Derrick, With or Without Attachments, With a Lifting Capacity of Over 100 Tons, Self-Erecting Tower Crane With a Lifting Capacity of Over 4,000 Lbs., Crane With Boom Dollies; Crane, Tower Crane, Pedestal Tower or Derrick, With Boom, Leads &/or Jib Lengths Measuring 176 Ft or Over; Master Mechanic. Future Increase(s): Add \$1.60/hr on 6/3/2016. Premium Increase(s):	37.67	20.38	58.05

Fringe Benefits Must Be Paid On <u>All</u> Hours Worked		HOURLY BASIC RATE OF PAY	HOURLY FRINGE BENEFITS	TOTAL
CODE	TRADE OR OCCUPATION	\$	\$	\$
	Add \$.50/hr for >200 Ton; Add \$1/hr at 300 Ton; Add \$1.50/hr at 400 Ton; Add \$2/hr at 500 Ton & Over.			
509	Backhoe (Track Type) Having a Mfgr's Rated Capacity of 130,000 Lbs. or Over; Boring Machine (Horizontal or Vertical); Caisson Rig; Crane, Tower Crane, Portable Tower, Pedestal Tower or Derrick, With or Without Attachments, With a Lifting Capacity of 100 Tons or Under, Self-Erecting Tower Crane With A Lifting Capacity Of 4,000 Lbs. & Under; Crane, Tower Crane, Portable Tower, Pedestal Tower or Derrick, With Boom, Leads &/or Jib Lengths Measuring 175 Ft or Under; Pile Driver; Versi Lifts, Tri-Lifts & Gantrys (20,000 Lbs. & Over). Future Increase(s): Add \$1.60/hr on 6/3/2016. Premium Increase(s): Add \$.25/hr for all >45 Ton lifting capacity cranes.	36.42	20.38	56.80
510	Backhoe (Track Type) Having a Mfgr.'s Rated Capacity of Under 130,000 Lbs., Backhoe (Mini, 15,000 Lbs. & Under); Concrete Bump Cutter, Grinder, Planing or Grooving Machine; Concrete Laser/Screed; Concrete Paver (Slipform); Concrete Pump (Over 46 Meter), Concrete Conveyor (Rotec or Bidwell Type); Concrete Slipform Placer Curb & Gutter Machine; Concrete Spreader & Distributor; Dredge (NOT Performing Work on the Great Lakes); Forklift (Machinery Moving or Steel Erection, 25 Ft & Over); Gradall (Cruz-Aire Type); Hydro-Blaster (10,000 PSI or Over); Milling Machine; Skid Rig; Traveling Crane (Bridge Type). Future Increase(s): Add \$1.60/hr on 6/3/2016.	35.22	20.38	55.60
511	Air, Track, Rotary or Percussion Drilling Machine &/or Hammers, Blaster; Bulldozer or Endloader (Over 40 hp); Compactor (Self-Propelled 85 Ft Total Drum Width & Over, or Tractor Mounted, Towed & Light Equipment); Concrete Pump (46 Meter & Under), Concrete Conveyor (Rotec or Bidwell Type); Crane (Carry Deck, Mini) or Truck Mounted Hydraulic Crane (10 Tons or Under); Environmental Burner; Gantrys (Under 20,000 Lbs.); Grader or Motor Patrol; High Pressure Utility Locating Machine (Daylighting Machine); Manhoist; Material or Stack Hoist; Mechanic or Welder; Railroad Track Rail Leveling Machine, Tie Placer, Extractor, Tamper, Stone Leveler or Rehabilitation Equipment; Roller (Over 5 Ton); Scraper (Self Propelled or Tractor Drawn) 5 cu yd or More Capacity; Screed (Milling Machine); Sideboom; Straddle Carrier or Travel Lift; Tining or Curing Machine; Tractor (Scraper, Dozer, Pusher, Loader); Tractor or Truck Mounted Hydraulic Backhoe; Tractor or Truck Mounted Hydraulic Crane (10 Tons or Under); Trencher (Wheel Type or Chain Type Having Over 8-Inch Bucket). Future Increase(s): Add \$1.60/hr on 6/3/2016.	34.69	20.38	55.07

Fringe Benefits Must Be Paid On <u>All</u> Hours Worked		HOURLY BASIC RATE OF PAY	HOURLY FRINGE BENEFITS	TOTAL
CODE	TRADE OR OCCUPATION	\$	\$	\$
512	Backfiller; Broom or Sweeper; Bulldozer or Endloader (Under 40 hp); Compactor (Self-Propelled 84 Ft Total Drum Width & Under, or Tractor Mounted, Towed & Light Equipment); Concrete Batch Plant, Batch Hopper; Concrete Breaker (Large, Auto, Vibratory/Sonic, Manual or Remote); Concrete Conveyor System; Concrete Finishing Machine (Road Type); Fireman (Pile Driver & Derrick NOT Performing Work on the Great Lakes); Grout Pump; Hoist (Tugger, Automatic); Industrial Locomotives; Jeep Digger; Lift Slab Machine; Mulcher; Roller (Rubber Tire, 5 Ton or Under); Screw or Gypsum Pumps; Stabilizing or Concrete Mixer (Self-Propelled or 14S or Over); Stump Chipper; Trencher (Wheel Type or Chain Type Having 8-Inch Bucket & Under); Winches & A-Frames. Future Increase(s): Add \$1.60/hr on 6/3/2016.	32.62	20.38	53.00
513	Air Compressor (&/or 400 CFM or Over); Air, Electric or Hydraulic Jacking System; Augers (Vertical & Horizontal); Boatmen (NOT Performing Work on the Great Lakes); Boiler (Temporary Heat); Crusher, Screening or Wash Plant; Elevator; Farm or Industrial Type Tractor; Fireman (Asphalt Plant NOT Performing Work on the Great Lakes); Forklift; Generator (&/or 150 KW or Over); Greaser; Heaters (Mechanical); Loading Machine (Conveyor); Oiler; Post Hole Digger or Driver; Prestress Machine; Pump (3 Inch or Over) or Well Points; Refrigeration Plant or Freeze Machine; Robotic Tool Carrier (With or Without Attachments); Rock, Stone Breaker; Skid Steer Loader (With or Without Attachments); Vibratory Hammer or Extractor, Power Pack. Future Increase(s): Add \$1.60/hr on 6/3/2016.	31.99	20.38	52.37
514	Gas or Utility Pipeline, Except Sewer & Water (Primary Equipment). Future Increase(s): Add \$1/hr on 5/30/2016.	37.04	22.44	59.48
515	Gas or Utility Pipeline, Except Sewer & Water (Secondary Equipment).	33.82	20.30	54.12
516	Fiber Optic Cable Equipment	29.50	0.68	30.18

SEWER, WATER OR TUNNEL CONSTRUCTION
--

Includes those projects that primarily involve public sewer or water distribution, transmission or collection systems and related tunnel work (excluding buildings).

SKILLED TRADES

CODE	TRADE OR OCCUPATION	FRINGE BENEFITS MUST BE PAID ON <u>All</u> Hours Worked	HOURLY BASIC RATE OF PAY	HOURLY FRINGE BENEFITS	TOTAL
			\$	\$	\$
103	Bricklayer, Blocklayer or Stonemason		32.82	18.67	51.49
105	Carpenter		32.72	16.00	48.72
107	Cement Finisher Future Increase(s): Add \$1.75 on 6/1/16. Premium Increase(s): DOT PREMIUMS: 1) Pay two times the hourly basic rate on Sunday, New Year's Day, Memorial Day, Independence Day, Labor Day, Thanksgiving Day & Christmas Day. 2) Add \$1.40/hr when the Wisconsin Department of Transportation or responsible governing agency requires that work be performed at night under artificial illumination with traffic control and the work is completed after sunset and before sunrise.		35.97	17.85	53.82
109	Electrician		52.00	1.50	53.50
111	Fence Erector		18.72	5.78	24.50
116	Ironworker		32.50	20.58	53.08
118	Line Constructor (Electrical)		40.81	18.06	58.87
125	Pavement Marking Operator		30.00	18.81	48.81
126	Piledriver		33.24	16.00	49.24
130	Plumber Future Increase(s): Add \$1.50 on 6/1/16		39.95	19.45	59.40
135	Steamfitter		44.20	18.26	62.46
137	Teledata Technician or Installer		22.50	12.74	35.24
143	Tuckpointer, Caulker or Cleaner		32.82	18.67	51.49
144	Underwater Diver (Except on Great Lakes)		31.00	20.43	51.43
146	Well Driller or Pump Installer Future Increase(s): Add \$1/hr on 6/1/2016; Add \$1/hr on 6/1/2017.		25.32	16.40	41.72
150	Heavy Equipment Operator - ELECTRICAL LINE CONSTRUCTION ONLY		36.73	15.92	52.65
151	Light Equipment Operator -ELECTRICAL LINE CONSTRUCTION ONLY		32.65	15.52	48.17

Fringe Benefits Must Be Paid On <u>All</u> Hours Worked		HOURLY BASIC RATE OF PAY	HOURLY FRINGE BENEFITS	TOTAL
CODE	TRADE OR OCCUPATION	\$	\$	\$
152	Heavy Truck Driver - ELECTRICAL LINE CONSTRUCTION ONLY	28.57	13.71	42.28
153	Light Truck Driver - ELECTRICAL LINE CONSTRUCTION ONLY	26.53	13.55	40.08
154	Groundman - ELECTRICAL LINE CONSTRUCTION ONLY	21.75	12.97	34.72

TRUCK DRIVERS

Fringe Benefits Must Be Paid On <u>All</u> Hours Worked		HOURLY BASIC RATE OF PAY	HOURLY FRINGE BENEFITS	TOTAL
CODE	TRADE OR OCCUPATION	\$	\$	\$
201	Single Axle or Two Axle	19.00	0.00	19.00
203	Three or More Axle	19.00	0.00	19.00
204	Articulated, Euclid, Dumptor, Off Road Material Hauler	33.69	19.78	53.47
205	Pavement Marking Vehicle	19.00	0.00	19.00
207	Truck Mechanic	19.00	0.00	19.00

LABORERS

Fringe Benefits Must Be Paid On <u>All</u> Hours Worked		HOURLY BASIC RATE OF PAY	HOURLY FRINGE BENEFITS	TOTAL
CODE	TRADE OR OCCUPATION	\$	\$	\$
301	General Laborer Future Increase(s): Add \$1.25/hr eff. 06/06/2016 Premium Increase(s): Add \$.20 for blaster, bracer, manhole builder, caulker, bottomman and power tool; Add \$.55 for pipelayer; Add \$1.00 for tunnel work 0-15 lbs. compressed air; Add \$2.00 for over 15-30 lbs. compressed air; Add \$3.00 for over 30 lbs. compressed air.	27.18	15.64	42.82
303	Landscaper	41.00	0.00	41.00
304	Flagperson or Traffic Control Person	20.92	14.80	35.72
311	Fiber Optic Laborer (Outside, Other Than Concrete Encased)	19.35	0.00	19.35
314	Railroad Track Laborer	17.00	3.96	20.96

**HEAVY EQUIPMENT OPERATORS
SEWER, WATER OR TUNNEL WORK**

Fringe Benefits Must Be Paid On <u>All</u> Hours Worked		HOURLY BASIC RATE OF PAY	HOURLY FRINGE BENEFITS	TOTAL
CODE	TRADE OR OCCUPATION	\$	\$	\$
521	Backhoe (Track Type) Having a Mfgr.'s Rated Capacity of 130,000 Lbs. or Over; Caisson Rig; Crane, Tower Crane, Pedestal Tower or Derrick, With Boom, Leads &/or Jib Lengths Measuring 176 Ft or Over; Crane, Tower Crane, Pedestal Tower or Derrick, With or Without Attachments, With a Lifting Capacity of Over 100 Tons, Self-Erecting Tower Crane With a Lifting Capacity Of Over 4,000 Lbs., Crane With Boom Dollies; Master Mechanic; Pile Driver. Premium Increase(s): Add \$.25/hr for operating tower crane.	38.09	20.80	58.89
522	Backhoe (Track Type) Having a Mfgr.'s Rated Capacity of Under 130,000 Lbs., Backhoe (Mini, 15,000 Lbs. & Under); Boring Machine (Directional); Concrete Bump Cutter, Grinder, Planing or Grooving Machine; Concrete Laser/Screed; Concrete Paver (Slipform); Concrete Pump (Over 46 Meter), Concrete Conveyor (Rotec or Bidwell Type); Concrete Spreader & Distributor; Crane, Tower Crane, Portable Tower, Pedestal Tower or Derrick, With Boom, Leads &/or Jib Lengths Measuring 175 Ft or Under; Crane, Tower Crane, Portable Tower, Pedestal Tower or Derrick, With or Without Attachments, With a Lifting Capacity of 100 Tons or Under, Self-Erecting Tower Crane With a Lifting Capacity of 4,000 Lbs. & Under; Dredge (NOT Performing Work on the Great Lakes); Milling Machine; Skid Rig; Telehandler; Traveling Crane (Bridge Type). Future Increase(s): Add \$1.60/hr on 6/3/2016.	35.22	20.38	55.60
523	Air Track, Rotary or Percussion Drilling Machine &/or Hammers, Blaster; Boring Machine (Horizontal or Vertical); Bulldozer or Endloader (Over 40 hp); Crane (Carry Deck, Mini) or Truck Mounted Hydraulic Crane (10 Tons or Under); Concrete Pump (46 Meter & Under), Concrete Conveyor (Rotec or Bidwell Type); Concrete Slipform Placer Curb & Gutter Machine; Gradall (Cruz-Aire Type); Grader or Motor Patrol; Hydro-Blaster (10,000 PSI or Over); Manhoist; Material or Stack Hoist; Mechanic or Welder; Roller (Over 5 Ton); Scraper (Self Propelled or Tractor Drawn) 5 cu yd or More Capacity; Screed (Milling Machine); Sideboom; Straddle Carrier or Travel Lift; Tractor (Scraper, Dozer, Pusher, Loader); Tractor or Truck Mounted Hydraulic Backhoe; Tractor or Truck Mounted Hydraulic Crane (10 Tons or Under); Trencher (Wheel Type or Chain Type Having Over 8-Inch Bucket). Future Increase(s): Add \$1.60/hr on 6/3/2016.	34.69	20.38	55.07

Fringe Benefits Must Be Paid On <u>All</u> Hours Worked		HOURLY BASIC RATE OF PAY	HOURLY FRINGE BENEFITS	TOTAL
CODE	TRADE OR OCCUPATION	\$	\$	\$
524	Backfiller; Broom or Sweeper; Bulldozer or Endloader (Under 40 hp); Compactor (Self-Propelled 85 Ft Total Drum Width & Over, or Tractor Mounted, Towed & Light Equipment); Concrete Batch Plant, Batch Hopper; Concrete Breaker (Large, Auto, Vibratory/Sonic, Manual or Remote); Concrete Conveyor System; Concrete Finishing Machine (Road Type); Environmental Burner; Fireman (Pile Driver & Derrick NOT Performing Work on the Great Lakes); Forestry Equipment, Timbco, Tree Shear, Tub Grinder, Processor; Hoist (Tugger, Automatic); Grout Pump; Jeep Digger; Lift Slab Machine; Mulcher; Power Subgrader; Pump (3 Inch or Over) or Well Points; Robotic Tool Carrier (With or Without Attachments); Roller (Rubber Tire, 5 Ton or Under); Screw or Gypsum Pumps; Stabilizing or Concrete Mixer (Self-Propelled or 14S or Over); Stump Chipper; Tining or Curing Machine; Trencher (Wheel Type or Chain Type Having 8-Inch Bucket & Under); Winches & A-Frames.	33.69	21.75	55.44
525	Air Compressor (&/or 400 CFM or Over); Air, Electric or Hydraulic Jacking System; Augers (Vertical & Horizontal); Compactor (Self-Propelled 84 Ft Total Drum Width & Under, or Tractor Mounted, Towed & Light Equipment); Crusher, Screening or Wash Plant; Farm or Industrial Type Tractor; Fireman (Asphalt Plant NOT Performing Work on the Great Lakes); Generator (&/or 150 KW or Over); Heaters (Mechanical); High Pressure Utility Locating Machine (Daylighting Machine); Loading Machine (Conveyor); Post Hole Digger or Driver; Refrigeration Plant or Freeze Machine; Rock, Stone Breaker; Skid Steer Loader (With or Without Attachments); Vibratory Hammer or Extractor, Power Pack. Future Increase(s): Add \$1.60/hr on 6/3/2016.	31.99	20.38	52.37
526	Boiler (Temporary Heat); Forklift; Greaser; Oiler.	30.99	19.78	50.77
527	Work Performed on the Great Lakes Including Diver; Wet Tender or Hydraulic Dredge Engineer.	41.65	21.71	63.36
528	Work Performed on the Great Lakes Including 70 Ton & Over Tug Operator; Assistant Hydraulic Dredge Engineer; Crane or Backhoe Operator; Hydraulic Dredge Leverman or Diver's Tender; Mechanic or Welder.	41.65	21.71	63.36
529	Work Performed on the Great Lakes Including Deck Equipment Operator or Machineryman (Maintains Cranes Over 50 Tons or Backhoes 115,000 Lbs. or More); Tug, Launch or Loader, Dozer or Like Equipment When Operated on a Barge, Breakwater Wall, Slip, Dock or Scow, Deck Machinery.	36.72	21.15	57.87
530	Work Performed on the Great Lakes Including Deck Equipment Operator; Machineryman or Fireman (Operates 4 Units or More or Maintains Cranes 50 Tons or Under or Backhoes 115,000 Lbs. or Under), Deck Hand, Deck Engineer or Assistant Tug Operator; Off Road Trucks - Great Lakes ONLY.	36.72	21.15	57.87

LOCAL STREET OR MISCELLANEOUS PAVING CONSTRUCTION

Includes roads, streets, alleys, trails, bridges, paths, racetracks, parking lots and driveways (except residential or agricultural), public sidewalks or other similar projects (excluding projects awarded by the Wisconsin Department of Transportation).

SKILLED TRADES

Fringe Benefits Must Be Paid On <u>All</u> Hours Worked		HOURLY BASIC RATE OF PAY	HOURLY FRINGE BENEFITS	TOTAL
CODE	TRADE OR OCCUPATION	\$	\$	\$
103	Bricklayer, Blocklayer or Stonemason	32.82	18.67	51.49
105	Carpenter Future Increase(s): Add \$1.42/hr on 6/1/2016. Premium Increase(s): DOT PREMIUM: Pay two times the hourly basic rate on Sunday, New Year's Day, Memorial Day, Independence Day, Labor Day, Thanksgiving Day & Christmas Day.	33.02	17.12	50.14
107	Cement Finisher Future Increase(s): Add \$1.75 on 6/1/16. Premium Increase(s): DOT PREMIUMS: 1) Pay two times the hourly basic rate on Sunday, New Year's Day, Memorial Day, Independence Day, Labor Day, Thanksgiving Day & Christmas Day. 2) Add \$1.40/hr when the Wisconsin Department of Transportation or responsible governing agency requires that work be performed at night under artificial illumination with traffic control and the work is completed after sunset and before sunrise.	35.97	17.85	53.82
109	Electrician Future Increase(s): Add \$1.25/hr on 6/1/16. Premium Increase(s): DOT PREMIUM: Pay two times the hourly basic rate on Sunday, New Year's Day, Memorial Day, Independence Day, Labor Day, Thanksgiving Day & Christmas Day.	35.75	19.97	55.72
111	Fence Erector	18.72	5.78	24.50
116	Ironworker	32.50	20.58	53.08
118	Line Constructor (Electrical)	40.81	18.06	58.87
124	Painter	26.70	16.65	43.35
125	Pavement Marking Operator	30.00	18.81	48.81
126	Piledriver Future Increase(s): Add \$1.44/hr on 6/1/2016. Premium Increase(s): DOT PREMIUM: Pay two times the hourly basic rate on Sunday, New Year's Day, Memorial Day, Independence Day, Labor Day, Thanksgiving Day & Christmas Day.	33.56	17.12	50.68

Fringe Benefits Must Be Paid On <u>All</u> Hours Worked		HOURLY BASIC RATE OF PAY	HOURLY FRINGE BENEFITS	TOTAL
CODE	TRADE OR OCCUPATION	\$	\$	\$
133	Roofer or Waterproofer	29.65	1.71	31.36
137	Teledata Technician or Installer	22.50	12.74	35.24
143	Tuckpointer, Caulker or Cleaner	32.82	18.67	51.49
144	Underwater Diver (Except on Great Lakes)	36.74	16.00	52.74
150	Heavy Equipment Operator - ELECTRICAL LINE CONSTRUCTION ONLY	36.73	15.92	52.65
151	Light Equipment Operator -ELECTRICAL LINE CONSTRUCTION ONLY	32.65	15.52	48.17
152	Heavy Truck Driver - ELECTRICAL LINE CONSTRUCTION ONLY	28.57	13.71	42.28
153	Light Truck Driver - ELECTRICAL LINE CONSTRUCTION ONLY	26.53	13.55	40.08
154	Groundman - ELECTRICAL LINE CONSTRUCTION ONLY	21.75	12.97	34.72

TRUCK DRIVERS

Fringe Benefits Must Be Paid On <u>All</u> Hours Worked		HOURLY BASIC RATE OF PAY	HOURLY FRINGE BENEFITS	TOTAL
CODE	TRADE OR OCCUPATION	\$	\$	\$
201	Single Axle or Two Axle	18.00	0.00	18.00
203	Three or More Axle	18.00	0.00	18.00
204	Articulated, Euclid, Dumptor, Off Road Material Hauler Future Increase(s): Add \$1.60/hr on 6/3/2016.	34.69	20.38	55.07
205	Pavement Marking Vehicle	18.00	0.00	18.00
206	Shadow or Pilot Vehicle	18.00	0.00	18.00
207	Truck Mechanic	18.00	0.00	18.00

LABORERS

Fringe Benefits Must Be Paid On <u>All</u> Hours Worked		HOURLY BASIC RATE OF PAY	HOURLY FRINGE BENEFITS	TOTAL
CODE	TRADE OR OCCUPATION	\$	\$	\$
301	General Laborer	26.34	15.17	41.51

Fringe Benefits Must Be Paid On <u>All</u> Hours Worked		HOURLY BASIC RATE OF PAY	HOURLY FRINGE BENEFITS	TOTAL
CODE	TRADE OR OCCUPATION	\$	\$	\$
303	Landscaper Future Increase(s): Add \$1.00/hr eff. 06/01/2016; Add \$1.00/hr eff. 06/01/2017 Premium Increase(s): DOT PREMIUMS: 1) Pay two times the hourly basic rate on Sunday, New Year's Day, Memorial Day, Independence Day, Labor Day, Thanksgiving Day & Christmas Day. 2) Add \$1.25/hr for work on projects involving temporary traffic control setup, for lane and shoulder closures, when work under artificial illumination conditions is necessary as required by the project provisions (including prep time prior to and/or cleanup after such time period).	30.67	15.65	46.32
304	Flagperson or Traffic Control Person	20.92	14.80	35.72
311	Fiber Optic Laborer (Outside, Other Than Concrete Encased)	19.35	0.00	19.35
314	Railroad Track Laborer	17.00	3.96	20.96

**HEAVY EQUIPMENT OPERATORS
CONCRETE PAVEMENT OR BRIDGE WORK**

Fringe Benefits Must Be Paid On <u>All</u> Hours Worked		HOURLY BASIC RATE OF PAY	HOURLY FRINGE BENEFITS	TOTAL
CODE	TRADE OR OCCUPATION	\$	\$	\$
541	Crane, Tower Crane, Pedestal Tower or Derrick, With or Without Attachments, With a Lifting Capacity of Over 100 Tons, Self-Erecting Tower Crane With a Lifting Capacity Of Over 4,000 Lbs., Crane With Boom Dollies; Crane, Tower Crane, Pedestal Tower or Derrick, With Boom, Leads &/or Jib Lengths Measuring 176 Ft or Over; Master Mechanic. Future Increase(s): Add \$1.60/hr on 6/3/2016. Premium Increase(s): Add \$.50/hr for >200 Ton; Add \$1/hr at 300 Ton; Add \$1.50/hr at 400 Ton; Add \$2/hr at 500 Ton & Over.	37.67	20.38	58.05

Fringe Benefits Must Be Paid On <u>All</u> Hours Worked		HOURLY BASIC RATE OF PAY	HOURLY FRINGE BENEFITS	TOTAL
CODE	TRADE OR OCCUPATION	\$	\$	\$
542	<p>Backhoe (Track Type) Having a Mfgr.'s Rated Capacity of 130,000 Lbs. or Over; Caisson Rig; Crane, Tower Crane, Portable Tower, Pedestal Tower or Derrick, With or Without Attachments, With a Lifting Capacity of 100 Tons or Under, Self-Erecting Tower Crane With a Lifting Capacity of 4,000 Lbs. & Under; Crane, Tower Crane Portable Tower, Pedestal Tower or Derrick, With Boom, Leads &/or Jib Lengths Measuring 175 Ft or Under; Dredge (NOT Performing Work on the Great Lakes); Licensed Boat Pilot (NOT Performing Work on the Great Lakes); Pile Driver.</p> <p>Future Increase(s): Add \$1.30/hr on 6/1/2016; Add \$1.25/hr on 6/1/2017.</p> <p>Premium Increase(s): DOT PREMIUMS: 1) Pay two times the hourly basic rate on Sunday, New Year's Day, Memorial Day, Independence Day, Labor Day, Thanksgiving Day & Christmas Day. 2) Add \$1.50/hr night work premium. See DOT'S website for details about the applicability of this night work premium at: http://wisconsin.gov/Pages/doing-bus/civil-rights/labornwage/prevaling-wage-compliance.aspx.</p>	37.77	21.85	59.62
543	<p>Air Track, Rotary or Percussion Drilling Machine &/or Hammers, Blaster; Automatic Subgrader (Concrete); Backhoe (Track Type) Having a Mfgr.'s Rated Capacity of Under 130,000 Lbs., Backhoe (Mini, 15,000 Lbs. & Under); Boring Machine (Directional, Horizontal or Vertical); Bridge (Bidwell) Paver; Bulldozer or Endloader; Concrete Batch Plant, Batch Hopper; Concrete Breaker (Large, Auto, Vibratory/Sonic, Manual or Remote); Concrete Bump Cutter, Grinder, Planing or Grooving Machine; Concrete Conveyor System; Concrete Laser/Screed; Concrete Paver (Slipform); Concrete Pump, Concrete Conveyor (Rotec or Bidwell Type); Concrete Slipform Placer Curb & Gutter Machine; Concrete Spreader & Distributor; Crane (Carry Deck, Mini) or Truck Mounted Hydraulic Crane (10 Tons or Under); Crane With a Lifting Capacity of 25 Tons or Under; Forestry Equipment, Timbco, Tree Shear, Tub Grinder, Processor; Gradall (Cruz-Aire Type); Grader or Motor Patrol; Grout Pump; Hydro-Blaster (10,000 PSI or Over); Loading Machine (Conveyor); Manhoist; Material or Stack Hoist; Mechanic or Welder; Milling Machine; Post Hole Digger or Driver; Scraper (Self Propelled or Tractor Drawn) 5 cu yds or More Capacity; Shoulder Widener; Sideboom; Skid Rig; Stabilizing or Concrete Mixer (Self-Propelled or 14S or Over); Straddle Carrier or Travel Lift; Tractor (Scraper, Dozer, Pusher, Loader); Tractor or Truck Mounted Hydraulic Backhoe; Trencher (Wheel Type or Chain Type); Tube Finisher; Tugger (NOT Performing Work on the Great Lakes); Winches & A-Frames.</p> <p>Future Increase(s): Add \$1.30/hr on 6/1/2016; Add \$1.25/hr on 6/1/2017.</p> <p>Premium Increase(s): DOT PREMIUMS: 1) Pay two times the hourly basic rate on Sunday, New Year's Day, Memorial Day, Independence Day, Labor Day, Thanksgiving Day & Christmas Day. 2) Add \$1.50/hr night work premium. See DOT'S website for details about the applicability of this night work premium at: http://wisconsin.gov/Pages/doing-bus/civil-rights/labornwage/prevaling-wage-compliance.aspx.</p>	37.27	21.85	59.12

Fringe Benefits Must Be Paid On <u>All</u> Hours Worked		HOURLY BASIC RATE OF PAY	HOURLY FRINGE BENEFITS	TOTAL
CODE	TRADE OR OCCUPATION	\$	\$	\$
544	Backfiller; Belting, Burlap, Texturing Machine; Broom or Sweeper; Compactor (Self-Propelled or Tractor Mounted, Towed & Light Equipment); Concrete Finishing Machine (Road Type); Environmental Burner; Farm or Industrial Type Tractor; Fireman (Pile Driver & Derrick NOT Performing Work on the Great Lakes); Forklift; Greaser; Jeep Digger; Joint Sawyer (Multiple Blade); Launch (NOT Performing Work on the Great Lakes); Lift Slab Machine; Mechanical Float; Mulcher; Power Subgrader; Robotic Tool Carrier (With or Without Attachments); Self Propelled Chip Spreader; Shouldering Machine; Skid Steer Loader (With or Without Attachments); Telehandler; Tining or Curing Machine. Future Increase(s): Add \$1.30/hr on 6/1/2016; Add \$1.25/hr on 6/1/2017. Premium Increase(s): DOT PREMIUMS: 1) Pay two times the hourly basic rate on Sunday, New Year's Day, Memorial Day, Independence Day, Labor Day, Thanksgiving Day & Christmas Day. 2) Add \$1.50/hr night work premium. See DOT'S website for details about the applicability of this night work premium at: http://wisconsindot.gov/Pages/doing-bus/civil-rights/labornwage/prevailing-wage-compliance.aspx .	37.27	21.85	59.12
545	Air Compressor (&/or 400 CFM or Over); Air, Electric or Hydraulic Jacking System; Automatic Belt Conveyor & Surge Bin; Boiler (Temporary Heat); Concrete Proportioning Plant; Crusher, Screening or Wash Plant; Generator (&/or 150 KW or Over); Heaters (Mechanical); High Pressure Utility Locating Machine (Daylighting Machine); Mudjack; Oiler; Prestress Machine; Pug Mill; Pump (3 Inch or Over) or Well Points; Rock, Stone Breaker; Screed (Milling Machine); Stump Chipper; Tank Car Heaters; Vibratory Hammer or Extractor, Power Pack.	31.62	19.78	51.40
546	Fiber Optic Cable Equipment.	29.50	0.68	30.18
547	Work Performed on the Great Lakes Including Diver; Wet Tender or Hydraulic Dredge Engineer.	41.65	21.71	63.36
548	Work Performed on the Great Lakes Including 70 Ton & Over Tug Operator; Assistant Hydraulic Dredge Engineer; Crane or Backhoe Operator; Hydraulic Dredge Leverman or Diver's Tender; Mechanic or Welder. Future Increase(s): Add \$1.25/hr on 1/1/2017. Premium Increase(s): Add \$.50/hr for Friction Crane, Lattice Boom or Crane Certification (CCO).	44.05	23.24	67.29
549	Work Performed on the Great Lakes Including Deck Equipment Operator or Machineryman (Maintains Cranes Over 50 Tons or Backhoes 115,000 Lbs. or more); Tug, Launch or Loader, Dozer or Like Equipment When Operated on a Barge, Breakwater Wall, Slip, Dock or Scow, Deck Machinery.	36.72	21.15	57.87

550	Work Performed on the Great Lakes Including Deck Equipment Operator; Machineryman or Fireman (Operates 4 Units or More or Maintains Cranes 50 Tons or Under or Backhoes 115,000 Lbs. or Under); Deck Hand, Deck Engineer or Assistant Tug Operator; Off Road Trucks - Great Lakes ONLY.	36.72	21.15	57.87
-----	---	-------	-------	-------

**HEAVY EQUIPMENT OPERATORS
ASPHALT PAVEMENT OR OTHER WORK**

Fringe Benefits Must Be Paid On <u>All</u> Hours Worked		HOURLY BASIC RATE OF PAY	HOURLY FRINGE BENEFITS	TOTAL
CODE	TRADE OR OCCUPATION	\$	\$	\$
551	Crane, Tower Crane, Pedestal Tower or Derrick, With or Without Attachments, With a Lifting Capacity of Over 100 Tons, Self Erecting Tower Crane With a Lifting Capacity of Over 4,000 Lbs., Crane With Boom Dollies; Crane, Tower Crane, Pedestal Tower or Derrick, With Boom, Leads and/or Jib Lengths Measuring 176 Ft or Over; Master Mechanic.	36.67	19.78	56.45
552	Backhoe (Track Type) Having a Mfgr.'s Rated Capacity of 130,000 Lbs. or Over; Caisson Rig; Crane, Tower Crane, Portable Tower, Pedestal Tower or Derrick, With or Without Attachments, With a Lifting Capacity of 100 Tons or Under, Self-Erecting Tower Crane With a Lifting Capacity Of 4,000 Lbs. & Under; Crane, Tower Crane, Portable Tower, Pedestal Tower or Derrick, With Boom, Leads &/or Jib Lengths Measuring 175 Ft or Under; Dredge (NOT Performing Work on the Great Lakes); Licensed Boat Pilot (NOT Performing Work on the Great Lakes); Pile Driver. Future Increase(s): Add \$1.30/hr on 6/1/2016; Add \$1.25/hr on 6/1/2017. Premium Increase(s): DOT PREMIUMS: 1) Pay two times the hourly basic rate on Sunday, New Year's Day, Memorial Day, Independence Day, Labor Day, Thanksgiving Day & Christmas Day. 2) Add \$1.50/hr night work premium. See DOT'S website for details about the applicability of this night work premium at: http://wisconsindot.gov/Pages/doing-bus/civil-rights/labornwage/prevaling-wage-compliance.aspx .	37.77	21.85	59.62

Fringe Benefits Must Be Paid On <u>All</u> Hours Worked		HOURLY BASIC RATE OF PAY	HOURLY FRINGE BENEFITS	TOTAL
CODE	TRADE OR OCCUPATION	\$	\$	\$
553	Air, Track, Rotary or Percussion Drilling Machine &/or Hammers, Blaster; Asphalt Heater, Planer & Scarifier; Asphalt Milling Machine; Asphalt Screed; Backhoe (Track Type) Having a Mfgr.'s Rated Capacity of Under 130,000 Lbs., Backhoe (Mini, 15,000 Lbs. & Under); Bituminous (Asphalt) Plant & Paver, Screed; Boring Machine (Directional, Horizontal or Vertical); Bulldozer or Endloader; Concrete Breaker (Large, Auto, Vibratory/Sonic, Manual or Remote); Concrete Conveyor System; Concrete Laser/Screed; Concrete Slipform Placer Curb & Gutter Machine; Crane (Carry Deck, Mini) or Truck Mounted Hydraulic Crane (10 Tons or Under); Crane With a Lifting Capacity of 25 Tons or Under; Forestry Equipment, Timbco, Tree Shear, Tub Grinder, Processor; Gradall (Cruz-Aire Type); Grader or Motor Patrol; Hydro-Blaster (10,000 PSI or Over); Loading Machine (Conveyor); Manhoist; Material or Stack Hoist; Mechanic or Welder; Milling Machine; Post Hole Digger or Driver; Railroad Track Rail Leveling Machine, Tie Placer, Extractor, Tamper, Stone Leveler or Rehabilitation Equipment; Roller (Over 5 Ton); Scraper (Self Propelled or Tractor Drawn) 5 cu yds or More Capacity; Shoulder Widener; Sideboom; Skid Rig; Stabilizing or Concrete Mixer (Self-Propelled or 14S or Over); Tractor (Scraper, Dozer, Pusher, Loader); Tractor or Truck Mounted Hydraulic Backhoe; Trencher (Wheel Type or Chain Type); Tube Finisher; Tugger (NOT Performing Work on the Great Lakes); Winches & A-Frames. Future Increase(s): Add \$1.60/hr on 6/3/2016.	34.69	20.38	55.07
554	Backfiller; Broom or Sweeper; Compactor (Self-Propelled or Tractor Mounted, Towed & Light Equipment); Concrete Finishing Machine (Road Type); Environmental Burner; Farm or Industrial Type Tractor; Fireman (Asphalt Plant, Pile Driver & Derrick NOT Performing Work on the Great Lakes); Forklift; Greaser; Hoist (Tugger, Automatic); Jeep Digger; Joint Sawyer (Multiple Blade); Launch (NOT Performing Work on the Great Lakes); Lift Slab Machine; Mechanical Float; Mulcher; Power Subgrader; Robotic Tool Carrier (With or Without Attachments); Roller (Rubber Tire, 5 Ton or Under); Self-Propelled Chip Spreader; Shouldering Machine; Skid Steer Loader (With or Without Attachments); Telehandler.	36.17	19.19	55.36
555	Air Compressor (&/or 400 CFM or Over); Air, Electric or Hydraulic Jacking System; Augers (Vertical & Horizontal); Automatic Belt Conveyor & Surge Bin; Boiler (Temporary Heat); Crusher, Screening or Wash Plant; Generator (&/or 150 KW or Over); Heaters (Mechanical); High Pressure Utility Locating Machine (Daylighting Machine); Mudjack; Oiler; Prestress Machine; Pug Mill; Pump (3 Inch or Over) or Well Points; Rock, Stone Breaker; Screed (Milling Machine); Stump Chipper; Tank Car Heaters; Vibratory Hammer or Extractor, Power Pack. Future Increase(s): Add \$1.60/hr on 6/3/2016.	32.62	20.38	53.00
556	Fiber Optic Cable Equipment.	29.50	0.68	30.18

***** END OF RATES *****

The documents following the Prevailing Wage Rate Determination consist of twenty pages (including this one) of various forms/documents that will be used throughout the completion of the project. This prevailing wage rate determination and its underlying legal requirements outlined in the attached documents apply for the life of this project even though work on the project continues into 2017 or beyond. The chart below lists the form number, form/document name, the party who uses the document, and the document's number of pages. If you have any questions regarding these forms please call the Prevailing Wage Office at (608)266-6861.

ERD Form Number	Form Name	Party Who Uses the Form	Pages
	July 2015 description of recent changes to Wisconsin's prevailing wage laws resulting from enactment of the 2015-17 State Budget Bill.		1
	Prevailing Wage - Public Entity Project Owners	Explanation of project owner responsibilities	2
16056	Post the White Sheet	Contracting agency	1
10908	Consolidated List of Debarred Contractors	Any party contracting someone to complete work on a prevailing wage project	4
	Prevailing Wage – Contractors	Explanation of contractor responsibilities	2
7777	Disclosure of Ownership	Contractors that meet the criteria set out in (3)(A)&(B) of the form	1
5724	Prime Contractor Affidavit of Compliance	Prime contractor files with contracting agency upon completion of the work before receiving final payment	2
10584	Agent or Subcontractor Affidavit of Compliance	Subcontractors file with their awarding contractor upon completion of their work on the project before receiving final payment	2
10880	Request to Employ Subjourneyperson	Contractors wishing to employ a subjourneyperson(s)	1
	Additional General Prevailing Wage Law Information	General information for public entity or any other interested party	3

12/22/2015

THE 2015-17 BUDGET BILL MADE SIGNIFICANT CHANGES TO WISCONSIN'S PREVAILING WAGE LAWS. HOWEVER, THOSE CHANGES DO NOT GO INTO EFFECT UNTIL JANUARY 1, 2017.

During calendar year 2016, DWD will continue to enforce prevailing wage laws for local governmental unit and state agency public works projects under current prevailing wage laws.

2015 Wisconsin Act 55 (the budget bill) repealed the state prevailing wage law for **local governmental units** such as villages, towns, cities, school districts, or sewerage districts effective January 1, 2017. However, if a local governmental unit:

- issues a Request for Bids before January 1, 2017, for a project of public works that is subject to bidding or,
- enters into a contract before January 1, 2017, for a project of public works that is not subject to bidding,

then those public works projects are subject to the current prevailing wage law (§66.0903, Wis. Stats.) through the life of the project. Projects of public works with prevailing wage project determinations issued prior to 2017 continue to be subject to the current prevailing wage law through the life of the project even though the project may have work going on in 2017 or subsequent years.

Contractors working on local governmental unit projects with prevailing wage rate determinations must continue to pay employees the appropriate prevailing wage and maintain required prevailing wage payroll records. For instance, if a contractor is working in 2018 on a public works project with a project determination issued prior to 2017, then the contractor is required to comply with the "old" prevailing wage rate law (§66.0903, Wis. Stats.). After January 1, 2017, DWD will continue to enforce prevailing wage requirements for projects with DWD prevailing wage determinations issued under the "old" prevailing wage laws (§§ 66.0903 & 103.49, Wis. Stats.).

For new public works projects starting on January 1, 2017, state prevailing wage law will only apply to **state agency** and **state highway** projects. Prevailing wage rates applicable to state agencies will be those issued by the U.S. Department of Labor under the Davis-Bacon Act, 40 U.S.C. 3142. The Wisconsin Department of Administration will enforce the new state agency prevailing wage law (§16.856, Wis. Stats.) and the Wisconsin Department of Transportation will continue to enforce prevailing wage on state highway projects (under a law renumbered as §84.062, Wis. Stats.).

PREVAILING WAGE – Public Entity Project Owners

Any public works project that has a total estimated project cost that equals or exceeds single-trade or multiple-trade project thresholds requires a prevailing wage rate determination issued by the Department of Workforce Development (DWD). Public works include erecting, constructing, remodeling, repairing, demolishing, alterations, painting and decorating projects for a local governmental unit or state agency. State law excludes minor service or maintenance work, warranty work, or work under a supply-and-installation contract. There is a statutory definition for most of these exclusions. The prevailing wage law that applies to local governmental units is §66.0903, Wis. Stats. The prevailing wage law that applies to state agencies is §103.49, Wis. Stats. The applicable administrative rules for all public entities are DWD 290 and DWD 294, Wis. Adm. Code.

Thresholds

- A “single-trade project of public works” means a project in which a single trade accounts for 85% or more of the total labor cost of the project. The single trade threshold is \$48,000.
- A “multiple-trade project of public works” means a project in which no single trade accounts for 85% or more of the total labor cost of the project.
- (a) The multiple-trade threshold is \$100,000, unless a municipality falls under the description in (b).
 - (b) The multiple-trade threshold of \$234,000 applies to public works projects erected, constructed, repaired, remodeled, or demolished by a private contractor for •a city or village with a population less than 2500 or •a town.

A local governmental unit or state agency that has a public works project that equals or exceeds the prevailing wage thresholds must do all of the following:

- Request a prevailing wage rate determination for the project from DWD at least 30 days before soliciting bids or negotiating contracts. An Application for Prevailing Wage Rate Determination is available on the DWD website: http://dwd.wisconsin.gov/er/prevailing_wage_rate/default.htm
To avoid waiting for a project determination use the on-line application system that permits the user to generate a determination immediately and save all documents in PDF form to the user’s computer. Use this project determination on line application at the following address:

http://dwd.wisconsin.gov/er/prevaling_wage_rate/pw_online_determinations.htm

- Tell potential contractors the project is subject to state prevailing wage law when soliciting bids.
- Include the prevailing wage rate determination in the construction contract, or if there is no written contract, provide a copy of the project determination to each prime contractor.
- Award contracts to contractors who do *not* appear on the “Consolidated List of Debarred Contractors.”
- Notify contractors that they are required to have a written substance abuse testing program in place that fulfills the requirements of §103.503, Wis. Stats., before commencing work on the prevailing wage project.
- Post the prevailing wage rate determination on the project site. (This document is often referred to as “the white sheet.”)
- Notify project contractors that if DWD finds that a contractor violated the prevailing wage law, DWD will assess liquidated damages of 100% of the wages owed to employees.
- Obtain an Affidavit of Compliance from each prime contractor before making final payment for the project.

If the total estimated cost of the project exceeds the prevailing wage thresholds, a local governmental unit or state agency also must obtain a prevailing wage rate determination under the following circumstances:

- when a completed facility is leased, purchased, lease-purchased or otherwise acquired by or dedicated to a public entity in lieu of the public entity contracting for the project,
- when one public entity does work for another public entity,
- when a *private* entity will construct a road, street, bridge, sanitary sewer or water main project and dedicate it to a local governmental unit or the state for its ownership or maintenance (except for some residential subdivisions).

For more information, visit the prevailing wage website: http://dwd.wisconsin.gov/er/prevaling_wage_rate/default.htm. For further assistance, call the Equal Rights Division at 608-266-6861 and ask for prevailing wage.

POST THE WHITE SHEET

As the public entity receiving this prevailing wage rate determination, **YOU ARE REQUIRED** by law to post the prevailing wage rate determination (i.e., white sheet) in at least one conspicuous and easily accessible place on the project site that is available to all construction workers. The white sheet must remain posted from the onset of the project until all construction labor on the project has been completed.

[See, Wis. Admin. Code §DWD 290.12(1)]

Posting the white sheet inside the general contractor's trailer does not meet this requirement. That placement is not available/accessible to all workers and is not a location over which you have control.

If you have questions about posting, please call (608)266-6861 and ask for prevailing wage intake.

State of Wisconsin - Department of Workforce Development

This list has been prepared in accordance with the provisions of §§66.0903(12) and 103.49(7), Wis. Stats., and Chapter DWD 294 of the Wisconsin Administrative Code. All contractors on this list were found to have committed a "debarable offense" related to certain labor standard provisions determined or established for a state or local public works project. No state agency, local governmental unit or owner or developer may knowingly solicit bids from, negotiate with or award any contracts to or approve or allow any subcontracts with a debarred contractor, including all divisions, affiliates or other organizational elements of such contractor that are engaged in construction business activities, until the debarment is terminated. The name of each debarred contractor must remain on this list for a period of three (3) years from the termination date indicated below. The contractor is, however, only "debarred" from the "effective date" through the "termination date" indicated for that contractor. Questions regarding this list should be addressed to Jim Chiolino, Equal Rights Division, P. O. Box 8928, Madison, WI 53708 or call (608) 266-3345. Deaf, hearing or speech-impaired callers may contact the department by calling its TDD number (608) 264-8752.

<u>Name of Contractor</u>	<u>Address</u>	<u>Effective Date</u>	<u>Termination Date</u>	<u>Cause Code</u>	<u>Date of Violation(s)</u>	<u>Limitations/Deviations</u>
A-1 Duran Roofing & Insulation Services, Inc.	3700 N Fratney St Milwaukee, WI 53212	11/1/14	10/31/17	1, 2 and 4	2011- 2012	None
	or 8095 NW 64 th St Miami, FL 33166					
Abel, Mike	See, Abel Electric, Inc					
Abel Electric, Inc	3385 Belmar Rd Green Bay, WI 54313	9/1/12	8/31/15	1	2011	None
Alpha Electric, LLC	350 Business Park Dr Sun Prairie, WI 53590	8/1/15	7/31/18	4	2014	None
Arnie Christiansen Mason Contractors, LLC	2304 65 th Dr Franksville, WI 53126	9/1/14	8/31/16	1, 2 and 4	2011	None
Atkins, Scott	See, Freedom Insulation, Inc					
Boecker, Roger	See, R-Way Pumping, Inc					
Brechtl, Mark G	See, Ecodec, Inc					
Cargill Heating and Air Conditioning Company, Inc	3049 Edgewater La La Crosse, WI 54603	3/1/14	2/28/17	1 and 2	2011	None

<u>Name of Contractor</u>	<u>Address</u>	<u>Effective Date</u>	<u>Termination Date</u>	<u>Cause Code</u>	<u>Date of Violation(s)</u>	<u>Limitations/Deviations</u>
Castlerock Commercial Construction, Inc	PO Box 11699 Milwaukee, WI 53211-0699	2/1/12	1/31/15	1, 2 and 4	2009 & 2010	None
Christiansen, Andy	See, Arnie Christiansen Mason Contractors, LLC					
Christiansen, Arnold	See, Arnie Christiansen Mason Contractors, LLC					
Darnick, Gregory L	See, Darnick Trucking, LLC					
Darnick Trucking, LLC	W914 County Rd V Berlin, WI 54923	11/1/14	10/31/15	1, 2 and 4	2012 & 2013	None
Dem/Ex Group, Inc	805 S Adams St Manito, IL 61546	12/1/11	11/30/14	1 and 2	2010	None
Duran, Bernardo	See, A-1 Duran Roofing & Insulation Services and RRS2 Inc					
Ecodec, Inc	5106 Wintergreen Dr Madison, WI 53704	10/1/14	9/30/17	1	2011 & 2012	None
Fisher, Ed &/or Fisher, Rhonda	See, Dem/Ex Group, Inc					
Freedom Insulation, Inc	117925 219th Ave Chippewa Falls, WI 54729	9/1/11	8/31/14	1	2008- 2010	None
Froode, Kathleen M	See, Masonry Specialists II, LLC					
Galstad, Michael E (aka Michael Earl Galstad)	See, Cargill Heating and Air Conditioning Company, Inc					
Gjolaj, Ded	See, Horizon Bros Painting Corp					

<u>Name of Contractor</u>	<u>Address</u>	<u>Effective Date</u>	<u>Termination Date</u>	<u>Cause Code</u>	<u>Date of Violation(s)</u>	<u>Limitations/Deviations</u>
Grade A Construction, Inc	157 Enterprise Rd Delafield, WI 53018	1/1/16	12/31/19	1, 2 and 4	2014	None
Horizon Bros Painting Corp	1053 Kendra La Howell, MI 48843	10/1/14	9/30/16	4	2012	None
JT Roofing, Inc	350 Tower Dr Saukville, WI 53080	6/1/12	5/31/15	1, 2 and 4	2007 & 2008	None
Jinkins, Richard	See, Castlerock Commercial Construction, Inc					
John's Concrete	See, Wagner Companies, Inc, dba John's Concrete					
Kott, Joseph J	See, Alpha Electric, LLC					
Masonry Specialists II, LLC	5109 Briarwood Ct Racine, WI 53402	8/1/15	7/31/18	4	2014	None
Mid-W Enterprises, Inc	1730 22 nd Avenue Kenosha, WI 53140	6/1/15	5/31/17	1, 2 and 4	2013	None
Midwest Construction Co, Inc	See, Mid-W Enterprises, Inc					
Oden, Cassie	See, A-1 Duran Roofing & Insulation Services and RRS2 Inc					
Ofstie, Darin	See, Precision Excavating and Grading, LLC					
Peret, Robert	See, A-1 Duran Roofing & Insulation Services and RRS2 Inc					

<u>Name of Contractor</u>	<u>Address</u>	<u>Effective Date</u>	<u>Termination Date</u>	<u>Cause Code</u>	<u>Date of Violation(s)</u>	<u>Limitations/Deviations</u>
Precision Excavating and Grading, LLC or Precision Excavating Enterprises, LLC	2104 Pierce Saint Croix Rd Baldwin, WI 54002	5/1/11	4/30/14	1, 2 and 4	2006- 2008	None
R-Way Pumping, Inc	3023 Lake Maria Rd Freeport, MN 56331	3/1/12	2/28/15	1, 2 and 4	2008	None
RRS2 Inc.	133 N Jackson St, #427 Milwaukee, WI 53202 or 1313 N Franklin Pl, #805 Milwaukee, WI 53202	11/1/14	10/31/17	1, 2 and 4	2011- 2012	None
Thull, Gerald T	See, JT Roofing, Inc					
Ventura, Robert	See, Mid-W Enterprises, Inc					
Wagner, Cory L	See, Wagner Companies, Inc					
Wagner Companies, Inc, dba John's Concrete	2063 Georgia Ave Racine, WI 53404	8/1/15	7/31/18	1	2013	None
Yaresh, Kathleen R	See, Grade A Construction, Inc					

Cause Code: 1 = Failure to Pay Straight Time 2 = Failure to Pay Overtime 3 = Kickback 4 = Payroll Records.

PREVAILING WAGE – Contractors

Any public works project that has a total estimated project cost that equals or exceeds prevailing wage project thresholds requires a prevailing wage rate determination issued by the Department of Workforce Development (DWD). Public works include erecting, constructing, remodeling, repairing, demolishing, alterations, painting and decorating projects for a local governmental unit or state agency. State law excludes minor service or maintenance work, warranty work, or work under a supply-and-installation contract. There is a statutory definition for most of these exclusions. The prevailing wage laws that apply to local governmental units and their contractors are §§66.0903 and 103.503, Wis. Stats. The prevailing wage laws that apply to state agencies and their contractors are §§103.49 and 103.503, Wis. Stats. The applicable administrative rules for all prevailing wage projects are DWD 290 and DWD 294, Wis. Adm. Code. These laws include provisions that apply to all contractors and subcontractors working on prevailing wage projects.

Any contractor or subcontractor working on a local governmental unit or state agency's public works project that equals or exceeds current prevailing wage project thresholds must do all of the following:

- Receive and review the project's prevailing wage rate determination (i.e., white sheet).
- Tell subcontractors the project is subject to state prevailing wage law and include the prevailing wage rate determination in the construction contract, or if there is no written contract, provide a copy of the project determination to each subcontractor.
- Hire subcontractors who do *not* appear on the "Consolidated List of Debarred Contractors."
- Have a written substance abuse testing program in place that fulfills the requirements of §103.503, Wis. Stats., before commencing work on the project.

- Notify subcontractors that if DWD finds that a contractor or subcontractor violated the prevailing wage law, DWD will assess liquidated damages of 100% of the wages owed to employees.
- Apply to DWD for subjourney wage rates prior to employing these individuals on the project.
- Receive and retain a completed Affidavit of Compliance from each subcontractor brought on to the project before providing final payment to those subcontractors.
- Submit a completed Affidavit of Compliance to the contractor who brought the subcontractor on to the project before receiving final payment for the project.
- Maintain payroll records for 3 years that comply with §§66.0903(10)(a) or 103.49(5)(a), Stats. and DWD 274.06.
- Respond to requests from DWD or the project owner to provide payroll records and/or respond to prevailing wage complaints filed by employees or third parties.

For more information, visit the prevailing wage website: http://dwd.wisconsin.gov/er/prevailing_wage_rate/default.htm. For further assistance, call the Equal Rights Division at 608-266-6861 and ask for prevailing wage.

Disclosure of Ownership

The statutory authority for the use of this form is prescribed in Sections 66.0903(12)(d), 66.0904(10)(d) and 103.49(7)(d), Wisconsin Statutes.

The use of this form is mandatory. The penalty for failing to complete this form is prescribed in Section 103.005(12), Wisconsin Statutes.

Personal information you provide may be used for secondary purposes [Privacy Law, s. 15.04(1) (m), Wisconsin Statutes].

- (1) On the date a contractor submits a bid to or completes negotiations with a state agency, local governmental unit, or developer, investor or owner on a project subject to Section 66.0903, 66.0904 or 103.49, Wisconsin Statutes, the contractor shall disclose to such state agency, local governmental unit, or developer, investor or owner, the name of any "other construction business," which the contractor, or a shareholder, officer or partner of the contractor, owns or has owned within the preceding three (3) years.
- (2) The term "other construction business" means any business engaged in the erection, construction, remodeling, repairing, demolition, altering or painting and decorating of buildings, structures or facilities. It also means any business engaged in supplying mineral aggregate, or hauling excavated material or spoil as provided by Sections 66.0903(3), 66.0904(2), 103.49(2) and 103.50(2), Wisconsin Statutes.
- (3) This form must ONLY be filed, with the state agency project owner, local governmental unit project owner, or developer, investor or owner of a publicly funded private construction project that will be awarding the contract, if **both (A) and (B) are met.**
 - (A) The contractor, or a shareholder, officer or partner of the contractor:
 - (1) Owns at least a 25% interest in the "other construction business," indicated below, on the date the contractor submits a bid or completes negotiations; or
 - (2) Has owned at least a 25% interest in the "other construction business" at any time within the preceding three (3) years.
 - (B) The Wisconsin Department of Workforce Development (DWD) has determined that the "other construction business" has failed to pay the prevailing wage rate or time and one-half the required hourly basic rate of pay, for hours worked in excess of the prevailing hours of labor, to any employee at any time within the preceding three (3) years.

Other Construction Business

Business Name			
Street Address or P O Box	City	State	Zip Code
Business Name			
Street Address or P O Box	City	State	Zip Code
Business Name			
Street Address or P O Box	City	State	Zip Code
Business Name			
Street Address or P O Box	City	State	Zip Code

I hereby state under penalty of perjury that the information, contained in this document, is true and accurate according to my knowledge and belief.

Print the Name of Authorized Officer			
Authorized Officer Signature	Date Signed		
Corporation, Partnership or Sole Proprietorship Name			
Street Address or P O Box	City	State	Zip Code

If you have any questions call (608) 266-6861

Prime Contractor Affidavit of Compliance With Prevailing Wage Rate Determination

Authorization for this form is provided under Sections 66.0903(9)(c), 66.0904(7)(c) and 103.49(4r)(c) Wisconsin Statutes.

The use of this form is mandatory. The penalty for failing to complete this form is prescribed in Section 103.005(12), Wisconsin Statutes.

Personal information you provide may be used for secondary purposes [Privacy Law, s. 15.04(1)(m), Wisconsin Statutes].

This form must **ONLY** be filed with the **Awarding Agency** indicated below.

State Of _____))SS County Of _____)	Project Name	
	DWD Determination Number	Project Number (if applicable)
	Date Determination Issued	Date of Contract
	Awarding Agency	
	Date Work Completed	

After being duly sworn, the person whose name and signature appears below hereby states under penalty of perjury that

- **I am** the duly authorized officer of the corporation, partnership, sole proprietorship or business indicated below and have recently completed all of the work required under the terms and conditions of a contract with the above-named awarding agency and make this affidavit in accordance with the requirements set forth in Section 66.0903(9)(c), 66.0904(7)(c) or 103.49(4r)(c), Wisconsin Statutes and Chapter DWD 290 of the Wisconsin Administrative Code in order to obtain FINAL PAYMENT from such awarding agency.
- **I have** fully complied with all the wage and hour requirements applicable to this project, including all of the requirements set forth in the prevailing wage rate determination indicated above which was issued for such project by the Department of Workforce Development on the date indicated above.
- **I have** received the required affidavit of compliance from each of my agents and subcontractors that performed work on this project and have listed each of their names and addresses on page 2 of this affidavit.
- **I have** full and accurate records that clearly indicate the name and trade or occupation of every worker(s) that I employed on this project, including an accurate record of the hours worked and actual wages paid to such worker(s).
- **I will** retain the records and affidavit(s) described above and make them available for inspection for a period of at least three (3) years from the completion date indicated above at the address indicated below and shall not remove such records or affidavit(s) without prior notification to the awarding agency indicated above.

Name of Corporation, Partnership, Sole Proprietorship, Business, State Agency or Local Governmental Unit				
Street Address	City	State	Zip Code	Telephone Number
Print Name of Authorized Officer			Date Signed	
Signature of Authorized Officer				

List of Agents and Subcontractors

Name			Name		
Street Address			Street Address		
City	State	Zip Code	City	State	Zip Code
Telephone Number			Telephone Number		
Name			Name		
Street Address			Street Address		
City	State	Zip Code	City	State	Zip Code
Telephone Number			Telephone Number		
Name			Name		
Street Address			Street Address		
City	State	Zip Code	City	State	Zip Code
Telephone Number			Telephone Number		
Name			Name		
Street Address			Street Address		
City	State	Zip Code	City	State	Zip Code
Telephone Number			Telephone Number		
Name			Name		
Street Address			Street Address		
City	State	Zip Code	City	State	Zip Code
Telephone Number			Telephone Number		
Name			Name		
Street Address			Street Address		
City	State	Zip Code	City	State	Zip Code
Telephone Number			Telephone Number		

If you have any questions call (608) 266-6861

Agent or Subcontractor Affidavit of Compliance With Prevailing Wage Rate Determination

Authorization for this form is provided under Sections 66.0903(9)(b), 66.0904(7)(b) and 103.49(4r)(9b), Wisconsin Statutes. The use of this form is mandatory. The penalty for failing to complete this form is prescribed in Section 103.005(12), Wisconsin Statutes.

Personal information you provide may be used for secondary purposes [Privacy Law, Section 15.04(1)(m), Wisconsin Statutes].

This form must **ONLY** be filed with the **Awarding Contractor** indicated below.

State Of _____))SS County Of _____)	Project Name	
	DWD Determination Number	Project Number (if applicable)
	Date Determination Issued	Date of Subcontract
	Awarding Contractor	
	Date Work Completed	

After being duly sworn, the person whose name and signature appears below hereby states under penalty of perjury that

- **I am** the duly authorized officer of the corporation, partnership, sole proprietorship or business indicated below. We have recently completed all of the work required under the terms and conditions of a subcontract with the above-named awarding contractor. We make this affidavit in accordance with the requirements set forth in Section 66.0903(9)(b), 66.0904(7)(b) or 103.49(4r)(b), Wisconsin Statutes and Chapter DWD 290 of the Wisconsin Administrative Code in order to obtain FINAL PAYMENT from such awarding contractor.
- **I have** fully complied with the entire wage and hour requirements applicable to this project, including all of the requirements set forth in the prevailing wage rate determination indicated above which was issued for such project by the Department of Workforce Development on the date indicated above.
- **I have** received the required affidavit of compliance from each of my agents and subcontractors that performed work on this project and have listed each of their names and addresses on page 2 of this affidavit.
- **I have** full and accurate records that clearly indicate the name and trade or occupation of every worker(s) that I employed on this project, including an accurate record of the hours worked and actual wages paid to such worker(s).
- **I will** retain the records and affidavit(s) described above and make them available for inspection for a period of at least three (3) years from the completion date indicated above at the address indicated below and shall not remove such records or affidavit(s) without prior notification to the awarding contractor.

Name of Corporation, Partnership, Sole Proprietorship, Business, State Agency or Local Governmental Unit				
Street Address or PO Box	City	State	Zip Code	Telephone Number ()
Print Name of Authorized Officer			Date Signed	
Authorized Officer Signature				

List of Agents and Subcontractors

Name			Name		
Street Address			Street Address		
City	State	Zip Code	City	State	Zip Code
Telephone Number ()			Telephone Number ()		
Name			Name		
Street Address			Street Address		
City	State	Zip Code	City	State	Zip Code
Telephone Number ()			Telephone Number ()		
Name			Name		
Street Address			Street Address		
City	State	Zip Code	City	State	Zip Code
Telephone Number ()			Telephone Number ()		
Name			Name		
Street Address			Street Address		
City	State	Zip Code	City	State	Zip Code
Telephone Number ()			Telephone Number ()		
Name			Name		
Street Address			Street Address		
City	State	Zip Code	City	State	Zip Code
Telephone Number ()			Telephone Number ()		
Name			Name		
Street Address			Street Address		
City	State	Zip Code	City	State	Zip Code
Telephone Number ()			Telephone Number ()		

If you have any questions call (608) 266-6861

Request to Employ Subjourneyperson

The use of this form is mandatory. The penalty for failing to complete this form is prescribed in Section 103.005(12), Wisconsin Statutes. Personal information you provide may be used for secondary purposes (Privacy Law, s. 15.04(1)(m), Wisconsin Statutes).

The employer indicated below requests that the Department of Workforce Development (DWD) determine the prevailing wage rate(s) and related qualifications to enable such employer to use a subjourneyperson(s) on the following prevailing wage project, in accordance with the provisions of Section DWD 290.025, Wisconsin Administrative Code.

1. Name of Project Appearing on the Project Determination			
County	City, Village or Town		
DWD Project Determination Number	Project Number (if applicable)		
2. Job Classification(s) for which you request a subjourney rate (i.e., carpenter, electrician, plumber, etc.)			
a.	b.		
c.	d.		
3. Employer Name (Print)			
Address	City	State	Zip Code
Telephone Number ()	Requester Title		
Email address (if you prefer to receive your response via email)	Fax Number (if you prefer to receive your response via fax) ()		

READ CAREFULLY: I understand that this request is ONLY applicable to the project and job classification(s) listed above and that subjourney employees primarily work under the direction of and assist a skilled trade employee by frequently using the tools of a skilled trade and will NOT regularly perform the duties of a general laborer, heavy equipment operator or truck driver. If the subjourney employee regularly performs the work of a different trade or occupation, he/she will be compensated for such work at the applicable journeyperson prevailing wage rate. I agree to compensate subjourney employees in strict accordance with the directions received from the DWD.

Requester Signature _____ Date Signed _____

MAIL the completed request to:
 EQUAL RIGHTS DIVISION, LABOR STANDARDS BUREAU
 PO BOX 8928, MADISON WI 53708
OR
 FAX the completed request to: (608) 267-4592 / **DO NOT e-mail your request.**
 Call (608) 266-6861 for assistance in completing this form.

ADDITIONAL GENERAL PREVAILING WAGE LAW INFORMATION

(This document updated July 2015)

NOTE: Recent prevailing wage law changes enacted by the 2015-17 Budget Bill (2015 Wisconsin Act 55) do not go into effect until calendar year 2017.

For prevailing wage laws and frequently asked questions, refer to the prevailing wage website at:
http://dwd.wisconsin.gov/er/prevailing_wage_rate/default.htm

Topic	Who's affected?	Brief description of requirement under §66.0903 or §103.49
Non-applicability	All public entities	Prevailing wage rates do not apply to minor service or maintenance work, warranty work, or work under a supply and installation contract.
Non-applicability: Minor service or maintenance work	Local governmental units & Contractors	Minor service or maintenance work means a project of public works that is limited to <ul style="list-style-type: none"> • minor crack filling, chip or slurry sealing, or other minor pavement patching, not including overlays, that has a projected life span of no longer than 5 years or that is performed for a TOWN and is not funded under §86.31, regardless of projected life span; • the depositing of gravel on an existing gravel road applied solely to maintain the road; • road shoulder maintenance; • cleaning of drainage or sewer ditches or structures; or • any other limited, minor work on public facilities or equipment that is routinely performed to prevent breakdown or deterioration.
Non-applicability: Minor service or maintenance work	State agencies	Minor service or maintenance work means a project of public works that is limited to <ul style="list-style-type: none"> • minor crack filling, chip or slurry sealing, or other minor pavement patching, not including overlays, that has a projected life span of no longer than 5 years; • cleaning of drainage or sewer ditches or structures; or • any other limited, minor work on public facilities or equipment that is routinely performed to prevent breakdown or deterioration.
Non-applicability: Supply & installation contract	All public entities	Supply and installation contract means a contract under which the material is installed by means of simple fasteners or connectors such as screws or nuts and bolts and no other work is performed on the site of the project of public works, and the total labor cost to install the material does not exceed 20 percent of the total cost of the contract.
Non-applicability: Work which a contractor or individual donates to a public entity	All public entities	Prevailing wage laws §§66.0903 & 103.49, Stats., do not apply to work performed on a project of public works for which the local governmental unit or the state or the state agency contracting for the project is not required to compensate any contractor, subcontractor, contractor's or subcontractor's agent, or individual for performing the work.

Topic	Who's affected?	Brief description of requirement under §66.0903 or §103.49
Non-applicability: Residential	All public entities	A prevailing wage rate determination is not required for the erection, construction, repair, remodeling, or demolition of a residential property containing 2 dwelling units or less.
Non-applicability: Residential subdivision infrastructure	All public entities	A prevailing wage rate determination is not required for a road, street, bridge, sanitary sewer, or water main project that is a part of a development in which at least 90 percent of the lots contain or will contain 2 dwelling units or less, as determined by the local governmental unit at the time of approval of the development, and that, on completion, is acquired by, or dedicated to, a local governmental unit (including under §236.13(2), Stats.), or the state, for ownership or maintenance by the local governmental unit or the state.
Electronic certified payroll record	Contractors	The requirement that every contractor on a prevailing wage project submit to DWD monthly a certified record of employees who worked on the project and that DWD post these certified records on its Internet website was discontinued effective July 1, 2011. Contractors are still required to maintain payroll records and provide them upon request from DWD &/or the project owner.
Payroll record inspection request by any person	Contractors & Complainants	Any person may request DWD to inspect the payroll records of any contractor working on a prevailing wage project. On receipt of such a request, the contractor must submit to DWD a certified record of its payroll records, other than personally identifiable information relating to an employee of the contractor, for no longer than a 4-week period. DWD may request records from a contractor under this provision no more than once per calendar quarter for each project of public works on which the contractor is performing work. The department may not charge a requester a fee for obtaining that information. DWD must make these certified records available for public inspection.
Statewide uniformity	Local governmental units	A local governmental unit may not enact & administer a prevailing wage ordinance/provision for public works or publicly funded private construction projects. Any extant laws to that effect are void.
Substance Abuse Testing	Contractors & Workers	Before commencing work on a prevailing wage project, a contractor must have a written substance abuse testing program in place that complies with §103.503, Wis. Stats. No employee may use, possess, attempt to possess, distribute, deliver, or be under the influence of a drug or under the influence of alcohol while performing work on a prevailing wage project.

Topic	Who's affected	Brief description of requirement under §66.0903 or §103.49
<p>Covered employees</p>	<p>Truck drivers & Other workers & Contractors</p>	<p>A laborer, worker, mechanic, or truck driver who is employed to process, manufacture, pick up, or deliver materials or products from a commercial establishment that has a fixed place of business from which the establishment supplies processed or manufactured materials or products or from a facility that is not dedicated exclusively, or nearly so, to a project of public works is NOT entitled to receive the prevailing wage rate UNLESS any of the following applies:</p> <ul style="list-style-type: none"> 1) the laborer, worker, mechanic, or truck driver is employed to go to the source of mineral aggregate such as sand, gravel, or stone and deliver that mineral aggregate to the site of a project of public works by depositing the material directly in final place, from the transporting vehicle or through spreaders from the transporting vehicle. 2) the laborer, worker, mechanic, or truck driver is employed to go to the site of a project of public works, pick up excavated material or spoil from the site of the project, and transport that excavated material or spoil away from the site of the project.

SECTION 01 00 00
BASIC REQUIREMENTS

PART 1 GENERAL

1.1 SECTION SUMMARY

- A. Section Includes:
1. Section Summary
 2. Summary of the Work
 3. Contractor Use of Premises
 4. Applications for Payment
 5. Change Procedures
 6. Alternates
 7. Coordination
 8. Cutting and Patching
 9. Conferences
 10. Progress Meetings
 11. Submittal Procedures
 12. Proposed Products List
 13. Shop Drawings
 14. Product Data
 15. Samples
 16. Manufacturers' Instructions
 17. Manufacturers' Certificates
 18. Quality Assurance / Quality Control of Installation
 19. References
 20. Interior Enclosures
 21. Protection of Installed Work
 22. Parking
 23. Staging Areas
 24. Occupancy During Construction and Conduct of Work
 25. Protection
 26. Progress Cleaning
 27. Products
 28. Transportation, Handling, Storage and Protection
 29. Product Options
 30. Substitutions
 31. Starting Systems
 32. Demonstration and Instructions
 33. Contract Closeout Procedures
 34. Final Cleaning
 35. Adjusting
 36. Operation and Maintenance Data
 37. Spare Parts and Maintenance Materials
 38. As-Built and Record Drawings and Specifications

1.2 SUMMARY OF THE WORK

- A. Project Description: Perform the Work as specified and detailed in Construction Documents package. Contractor to provide construction services and materials/equipment for construction of loading docks, canopy and site work adjacent to the Alliant Energy Center Veterans Memorial Coliseum. The exterior loading docks will provide improved loading/unloading for trucks during concerts and events held at the facility.
- B. Work by Owner: Not applicable.
- C. Permits: Prior to commencement of the Work, Contractor to secure any and all necessary permits for completion of the Work and facility occupancy.
- D. Diggers Hotline:
 - 1. It is the responsibility of the General Contractor to contact Diggers Hotline to have all utility locations marked prior to excavation and planning an excavation in a timely manner so as not to delay the Work.
 - 2. Diggers Hotline shall also be used to obtain information on safe working clearances from overhead lines.
 - 3. Completely comply with all requirements of each affected utility company.
 - 4. It is the responsibility of the General Contractor to contact & hire private utility locating services if necessary.

1.3 CONTRACTOR USE OF PREMISES

- A. Limit use of premises to allow work by Contractors or Subcontractors and access by Owner.

1.4 APPLICATIONS FOR PAYMENT

- A. Submit two (2) original copies with “wet” signatures of each application on AIA G702™ and G703™ forms or approved contractors invoice form.
- B. Content and Format: Utilize Schedule of Values for listing items in Application for Payment.
- C. Payment Period: Monthly.

1.5 CHANGE PROCEDURES

A. Contractor’s costs for Products, delivery, installation, labor, insurance, payroll, taxes, bonding, equipment rental, overhead and profit will be included in Change Orders authorizing expenditure of funds from contingency allowance.

1.6 ALTERNATES

- A. Alternates quoted on Bid Form shall be reviewed and accepted or rejected at the Owner's option.
- B. Coordinate related work and modify surrounding work as required.

- C. Schedule of Alternates: there are no alternates proposed for this project.

1.7 COORDINATION

- A. Coordinate scheduling, submittals, and work of various sections of Specifications to assure efficient and orderly sequence of installation of interdependent construction elements.
- B. Verify utility requirement characteristics of operating equipment are compatible with building utilities.
- C. Coordinate space requirements and installation of mechanical and electrical work that are indicated diagrammatically on Drawings.

1.8 CUTTING AND PATCHING

- A. Employ a skilled and experienced installer to perform cutting and patching new work; restore work with new Products.
- B. Submit written request in advance of cutting or altering structural or building enclosure elements.
- C. Fit work tight to adjacent elements. Maintain integrity of wall, ceiling, or floor construction; completely seal voids.
- D.

1.9 CONFERENCES

- A. Owner will schedule a preconstruction conference after Award of Contract for all affected parties.
- B. Contractor shall submit Construction Schedule at the pre-construction meeting.
- C. When required in individual Specification section, convene a pre-installation conference at project site prior to commencing work of the section.

1.10 PROGRESS MEETINGS

- A. Schedule and administer meetings at the Alliant Energy Center throughout progress of the Work at minimum of one (1) per week during construction and three (3) meetings total pre-construction.
- B. Preside at meetings, record minutes, and distribute copies within two (2) business days to those affected by decisions made.

1.11 SUBMITTAL PROCEDURES

- A. Submittal form to identify Project, Contractor, Subcontractor or supplier; and pertinent Construction Documents references.
- B. Apply Contractor's stamp, signed or initialed, certifying that review, verification of Products required, field dimensions, adjacent construction work, and coordination of information is in accordance with requirements of the Work and Construction Documents.
- C. Identify variations from Construction Documents and Product or system limitations that may be detrimental to successful performance of completing the Work.
- D. Revise and resubmit submittals as required; identify all changes made since previous submittal.

1.12 PROPOSED PRODUCTS LIST

- A. Within thirty (30) business days after date of Award of Contract, submit complete list of major Products proposed for use, with name of manufacturer, trade name, and model number of each Product.

1.13 SHOP DRAWINGS

- A. Contractor shall electronically submit Shop Drawings for each submission, until receiving final approval. When copies for distribution are requested submit the number of copies that Contractor requires, plus two copies that shall be retained by the Public Works Project Manager and the Architect/Engineer. Refer to General Conditions.

1.14 PRODUCT DATA

- A. Contractor shall electronically submit Product Data for each submission, until receiving final approval. When copies for distribution are requested submit the number of copies that Contractor requires, plus two copies that shall be retained by the Public Works Project Manager and the Architect/Engineer. Refer to General Conditions
- B. Mark each copy to identify applicable products, models, options, and other data. Supplement manufacturer's standard data to provide information unique to this Project.

1.15 SAMPLES

- A. Submit samples to illustrate functional and aesthetic characteristics of the Product.
- B. Submit samples of finishes from the full range of manufacturers' standard colors, textures, and patterns for Public Works Project Manager's selection.

1.16 MANUFACTURERS' INSTRUCTIONS

- A. When specified in individual Specification sections, submit manufacturers' printed instructions for delivery, storage, assembly, installation, start-up, adjusting, and finishing, in quantities specified for Product Data.

1.17 MANUFACTURERS' CERTIFICATES

- A. When specified in individual Specification sections, submit manufacturers' certificate to Public Works Project Manager for review, in quantities specified for Product Data.
- B. Indicate material or Product conforms to or exceeds specified requirements. Submit supporting reference data, affidavits, and certifications as appropriate.

1.18 QUALITY ASSURANCE / QUALITY CONTROL OF INSTALLATION

- A. Monitor quality control over suppliers, manufacturers, Products, services, site conditions, and workmanship, to produce work of specified quality.
- B. Comply fully with manufacturers' instructions.
- C. Comply with specified standards as minimum quality for the Work except when more stringent tolerances, codes, or specified requirements indicate higher standards or more precise workmanship.

1.19 REFERENCES

- A. Conform to reference standard by date of issue current as of date for receiving bids.
- B. Should specified reference standard conflict with Construction Documents, request clarification from Public Works Project Manager before proceeding.

1.20 INTERIOR ENCLOSURES

- A. Where applicable, such as during replacement of the overhead door, provide temporary partitions as required to separate work areas from Owner occupied areas, to prevent distribution of dust and moisture into Owner occupied areas, and to prevent damage to existing materials and equipment.

1.21 PROTECTION OF INSTALLED WORK

- A. Protect installed work and provide special protection where specified in individual Specification sections.

1.22 PARKING

- A. Arrange for temporary parking areas to accommodate construction personnel. Parking shall be available at the Work site.

1.23 STAGING AREAS

- A. Coordinate staging areas with Public Works Project Manager prior to starting the Work.
- B. On-site space for use as staging areas and storage of materials is available but will need to be approved by Alliant Energy Center staff to maintain ongoing operations in the area. Space will be apportioned among the various Contractors as their needs dictate with due regard for storage requirements of each Contractor. Each Contractor shall be responsible for safety of equipment and materials that are stored on site.

1.24 OCCUPANCY DURING CONSTRUCTION AND CONDUCT OF WORK

- A. Areas of existing facility will be occupied during period when the Work is in progress. Work may be done during normal business hours (7:00 am to 6:00 pm), but confer with Owner (additional times may be available with authorization), schedule work and store materials so as to interfere as little as possible with normal use of premises. Notify Owner when heavy equipment or similar noise making work is to be done and obtain Owner's written approval of schedule. If schedule is not convenient for Owner, reschedule and resubmit new times for Owner approval.
- B. Work shall be done and temporary facilities furnished so as not to interfere with access to any occupied area and so as to cause least possible interference with normal operation of facility or any essential service thereof.
- C. Contractor shall, at all times, provide approved, safe walkways and facility entrances for use by Owner, employees and public.
- D. Contractor shall provide adequate protection for all parts of facility, its contents and occupants wherever the Work under this Contract is to be performed.
- E. Contractor is responsible for providing & maintaining temporary toilet facilities.
- F. Each Contractor shall arrange with Owner to make necessary alterations, do new work, make connections to all utilities, etc., at such times as will not cause interruption of utility services to facility. Contractor doing this work shall protect, cap, cut off and / or replace and relocate existing pipes, electrical work and other active utilities encountered which may interfere with new construction work.
- G. New work in extension of existing work shall correspond in all respects with that to which it connects or similar existing work unless otherwise indicated or specified.
 - 1. Existing work shall be cut, altered, removed or replaced as necessary for performance of Contract obligations.
 - 2. Work remaining in place, damaged or defaced by reason of work done under this Contract shall be restored equal to its condition at time of Award of Contract.

1.25 PROTECTION

- A. Contractor shall protect from injury all landscaping, light poles, walks and driveways and pay for any damage to same resulting from insufficient or improper protection.

- B. Contractor shall provide and maintain barricades & signage to prohibit public access to construction site.
- C. Contractor shall provide and maintain guard lights at all barricades, railings, obstructions in streets, roads or sidewalks and at all trenches adjacent to public walks or roads.

1.26 PROGRESS CLEANING

- A. Maintain areas free of waste materials, debris, and rubbish. Maintain site in clean and orderly condition.

1.27 PRODUCTS

- A. Products: Means new material, machinery, components, equipment, fixtures, and systems forming the Work, but does not include machinery and equipment used for preparation, fabrication, conveying and erection of the Work. Products may also include existing materials or components specifically identified for reuse.
- B. Do not use materials and equipment removed from existing premises, except as specifically identified or allowed by Construction Documents.

1.28 TRANSPORTATION, HANDLING, STORAGE AND PROTECTION

- A. Transport, handle, store and protect Products in accordance with manufacturer's instructions.

1.29 PRODUCT OPTIONS

- A. Requests for material or product substitutions will be considered following the Award of Bid. Dane County reserves right to approve or reject substitutions based on Specification requirements and intended use and standard of quality

1.30 SUBSTITUTIONS

- A. Public Works Project Manager shall consider requests for Substitutions only within thirty (30) calendar days after date of Public Works Construction Contract. Substitution requests shall be reviewed by the A/E. Dane County reserves the right to approve or reject substitutions based on Specification requirements and intended use.
- B. Document each request with complete data substantiating compliance of proposed Substitution with Construction Documents.
- C. Electronically submit requests for Substitution consideration. Limit each request to one (1) proposed Substitution. Submit three (3) copies of requests for Substitution for consideration
- D. Substitutions shall not change contract price established at Bid Due Date.

1.31 STARTING SYSTEMS

- A. Provide written notification prior to start-up of each equipment item or system.
- B. Ensure that each piece of equipment or system is ready for operation.
- C. Execute start-up under supervision of responsible persons in accordance with manufacturers' instructions.
- D. Submit written report that equipment or system has been properly installed and is functioning correctly.

1.32 DEMONSTRATION AND INSTRUCTIONS

- A. Demonstrate operation and maintenance of Products to Owner's personnel prior to date of final inspection.
- B. Demonstrate start-up, operation, control, adjustment, trouble-shooting, servicing, maintenance, and shutdown of each item of equipment at agreed-upon times, at designated location.
- C. Owner may choose to videotape demonstration session; demonstration and demonstrator shall be to level of satisfaction of Owner.

1.33 CONTRACT CLOSEOUT PROCEDURES

- A. Submit written certification that Construction Documents have been reviewed, the Work has been inspected, and the Work is complete in accordance with Construction Documents and ready for Public Works Project Manager's inspection.
- B. Submit final Application for Payment identifying total adjusted Contract Sum / Price, previous payments, and amount remaining due. Provide Equal Benefits Compliance Form with final Application for Payment.

1.34 FINAL CLEANING

- A. Execute final cleaning prior to final inspection.
- B. Clean interior and exterior surfaces exposed to view.
- C. Remove waste and surplus materials, rubbish, and construction facilities from site.

1.35 ADJUSTING

- A. Adjust operating Products and equipment to ensure smooth and unhindered operation.

1.36 OPERATION AND MAINTENANCE MANUAL

- A. Provide operation and maintenance manual for all mechanical and electrical equipment and systems supplied and installed in the Work.

1.37 SPARE PARTS AND MAINTENANCE MATERIALS

- A. Provide Products, spare parts, maintenance and extra materials in quantities specified in individual Specification Sections.
- B. Deliver to the Work site and place in location as directed.

1.38 AS-BUILT AND RECORD DRAWINGS AND SPECIFICATIONS

- A. Contractor-produced Drawings and Specifications shall remain property of Contractor whether Project for which they are made is executed or not. Contractor shall furnish Public Works Project Manager with original marked up redlines of Construction Documents' drawings and specifications that shall include all Addendums, Change Orders, Construction Bulletins, on-site changes, field corrections, etc. These are the project As-Built Drawings & Specifications.
- B. Architect / Engineer shall update the original Construction Documents to include all Addendums & any other changes including those provided by the Contractor in the As-Built Drawings & Specifications. These updates are the project Record Drawings & Specifications.
- C. Architect / Engineer shall furnish the Public Works Project Manager with Record Drawings as detailed in the Professional Services Agreement.

PART 2 PRODUCTS

Not Used.

PART 3 EXECUTION

Not Used.

END OF SECTION

SECTION 01 74 19

RECYCLING

PART 1 GENERAL

1.1 SUMMARY

- A. Section Includes:
 - 1. Waste Management Goals
 - 2. Waste Management Plan
 - 3. Reuse
 - 4. Recycling
 - 5. Materials Sorting and Storage On Site
 - 6. Lists of Recycling Facilities Processors and Haulers
 - 7. Waste Management Plan Form

- B. Related Sections:
 - 1. Section 01 00 00 - Basic Requirements

1.2 WASTE MANAGEMENT GOALS

- A. Dane County requires that as many waste materials as possible produced as result of this project be salvaged, reused or recycled in order to minimize impact of construction waste on landfills and to minimize expenditure of energy and cost in fabricating new materials. Additional information may be found in The Dane County Green Building Policy, Resolution 299, 1999-2000.

- B. Contractor shall develop, with assistance of Public Works Project Manager and Architect / Engineer, Waste Management Plan (WMP) for this project. Outlined in RECYCLING section of this specification are examples of materials that can be recycled or reused as well as recommendations for waste sorting methods.

1.3 WASTE MANAGEMENT PLAN

- A. Contractor shall complete WMP and include cost of recycling / reuse in Bid. WMP will be submitted to Public Works Project Manager within fifteen (15) days of Notice to Proceed date. Copy of blank WMP form is in this Section. Submittal shall include cover letter and WMP form with:
 - 1. Information on:
 - a. Types of waste materials produced as result of work performed on site;
 - b. Estimated quantities of waste produced;
 - c. Identification of materials with potential to be recycled or reused;
 - d. How materials will be recycled or reused;
 - e. On-site storage and separation requirements (on site containers);
 - f. Transportation methods; and
 - g. Destinations.

1.4 REUSE

- A. Contractors and subcontractors are encouraged to reuse as many waste materials as possible. Salvage should be investigated for materials not reusable on site.

1.5 RECYCLING

- A. These materials can be recycled in Dane County area:
 1. Wood.
 2. Wood Pallets.
 3. Fluorescent Lamps.
 4. Foam Insulation & Packaging (extruded and expanded).
 5. PVC Plastic (pipe, siding, etc.).
 6. Asphalt & Concrete.
 7. Bricks & Masonry
 8. Corrugated Cardboard.
 9. Metal.
 10. Carpet Padding.
 11. Gypsum Drywall.
 12. Shingles.
 13. Barrels & Drums.
 14. Solvents.

1.6 MATERIALS SORTING AND STORAGE ON SITE

- A. Contractor shall provide separate containers for recyclable materials. Number of containers will be dependent upon project and site conditions.
- B. Contractor shall provide on-site locations for subcontractors supplied recycling containers to help facilitate recycling.

1.7 LISTS OF RECYCLING FACILITIES PROCESSORS AND HAULERS

- A. Web site www.countyofdane.com/pwht/recycle/categories.aspx lists current information for Dane County Recycling Markets. Contractors can also contact Dane County's Special Projects & Materials Manager at 608/266-4990, or local city, village, town recycling staff listed at site www.countyofdane.com/pwht/recycle/contacts.aspx. Statewide listings of recycling / reuse markets are available from UW Extension at www4.uwm.edu/shwec/wrmd/search.cfm.

1.8 WASTE MANAGEMENT PLAN FORM

A. Contractor Information:

Name: _____

Address: _____

Phone No.: _____ Recycling Coordinator: _____

MATERIAL	ESTIMATED QUANTITY	DISPOSAL METHOD (CHECK ONE)	RECYCLING / REUSE COMPANY OR DISPOSAL SITE
Salvaged & reused building materials	_____ cu. yds. _____ tons	_____ Recycled _____ Reused _____ Landfilled _____ Other	Name: _____
Glass	_____ cu. yds. _____ tons	_____ Recycled _____ Reused _____ Landfilled _____ Other	Name: _____
Wood	_____ cu. yds. _____ tons	_____ Recycled _____ Reused _____ Landfilled _____ Other	Name: _____
Wood Pallets	_____ units	_____ Recycled _____ Reused _____ Landfilled _____ Other	Name: _____
Fluorescent Lamps	_____ cu. ft. _____ lbs.	_____ Recycled _____ Reused _____ Landfilled _____ Other	Name: _____
Foam Insulation	_____ cu. ft. _____ lbs.	_____ Recycled _____ Reused _____ Landfilled _____ Other	Name: _____
Asphalt & Concrete	_____ cu. ft. _____ lbs.	_____ Recycled _____ Reused _____ Landfilled _____ Other	Name: _____
Bricks & Masonry	_____ cu. ft. _____ lbs.	_____ Recycled _____ Reused _____ Landfilled _____ Other	Name: _____
PVC Plastic	_____ cu. ft. _____ lbs.	_____ Recycled _____ Reused _____ Landfilled _____ Other	Name: _____
Corrugated Cardboard	_____ cu. ft. _____ lbs.	_____ Recycled _____ Reused _____ Landfilled _____ Other	Name: _____
Metals	_____ cu. yds. _____ tons	_____ Recycled _____ Reused _____ Landfilled _____ Other	Name: _____
Carpet Padding	_____ cu. ft. _____ lbs.	_____ Recycled _____ Reused _____ Landfilled _____ Other	Name: _____
Gypsum / Drywall	_____ cu. yds. _____ tons	_____ Recycled _____ Reused _____ Landfilled _____ Other	Name: _____

Shingles	_____ cu. yds. _____ tons	_____ Recycled _____ Landfilled	_____ Reused _____ Other	Name: _____
Barrels & Drums	_____ units	_____ Recycled _____ Landfilled	_____ Reused _____ Other	Name: _____
Solvents	_____ gallons	_____ Recycled _____ Landfilled	_____ Reused _____ Other	Name: _____
Other	_____	_____ Recycled _____ Landfilled	_____ Reused _____ Other	Name: _____
Other	_____	_____ Recycled _____ Landfilled	_____ Reused _____ Other	Name: _____
Other	_____	_____ Recycled _____ Landfilled	_____ Reused _____ Other	Name: _____
Other	_____	_____ Recycled _____ Landfilled	_____ Reused _____ Other	Name: _____
Other	_____	_____ Recycled _____ Landfilled	_____ Reused _____ Other	Name: _____

PART 2 PRODUCTS

Not Used.

PART 3 EXECUTION

Not Used.

END OF SECTION 01 74 19

SECTION 02 41 19

SELECTIVE DEMOLITION

PART 1 - GENERAL

1.1 SUMMARY

- A. This Section includes the following:
 - 1. Demolition and removal of selected portions of building or structure.
 - 2. Salvage of existing items to be reused or recycled.
- B. See Section 01 74 19 – Recycling regarding construction waste management.

1.2 DEFINITIONS

- A. Remove: Detach items from existing construction and legally dispose of them off-site, unless indicated to be removed and salvaged or removed and reinstalled.
- B. Remove and Salvage: Detach items from existing construction and deliver them to Owner ready for reuse.
- C. Remove and Reinstall: Detach items from existing construction, prepare them for reuse, and reinstall them where indicated.
- D. Existing to Remain: Existing items of construction that are not to be removed and that are not otherwise indicated to be removed.

1.3 SUBMITTALS

- A. Schedule of Selective Demolition Activities: Indicate detailed sequence of selective demolition and removal work, with starting and ending dates for each activity, interruption of utility services, use of elevator and stairs, and locations of temporary partitions and means of egress.
- B. Predemolition Photographs or Videotapes: Show existing conditions of adjoining construction and site improvements, including finish surfaces that might be misconstrued as damage caused by selective demolition operations.
- C. Landfill Records: Indicate receipt and acceptance of hazardous wastes by a landfill facility licensed to accept hazardous wastes.

1.4 QUALITY ASSURANCE

- A. Regulatory Requirements: Comply with governing EPA notification regulations before beginning selective demolition. Comply with hauling and disposal regulations of authorities having jurisdiction.
- B. Standards: Comply with ANSI A10.6 and NFPA 241.

- C. Predemolition Conference: Conduct conference at Project site.

1.5 PROJECT CONDITIONS

- A. Conditions existing at time of inspection for bidding purpose will be maintained by Owner as far as practical.
- B. Notify Architect of discrepancies between existing conditions and Drawings before proceeding with selective demolition.
- C. If materials suspected of containing hazardous materials are encountered, do not disturb; immediately notify Owner. Owner will remove hazardous materials under a separate contract.
- D. Storage or sale of removed items or materials on-site is not permitted.
- E. Utility Service: Maintain existing utilities indicated to remain in service and protect them against damage during selective demolition operations.
 - 1. Maintain fire-protection facilities in service during selective demolition operations.

1.6 WARRANTY

- A. Existing Warranties: Remove, replace, patch, and repair materials and surfaces cut or damaged during selective demolition, by methods and with materials so as not to void existing warranties.

PART 2 - PRODUCTS (Not Used)

PART 3 - EXECUTION

3.1 EXAMINATION

- A. Verify that utilities have been disconnected and capped.
- B. Survey existing conditions and correlate with requirements indicated to determine extent of selective demolition required.
- C. Inventory and record the condition of items to be removed and reinstalled and items to be removed and salvaged.
- D. When unanticipated mechanical, electrical, or structural elements that conflict with intended function or design are encountered, investigate and measure the nature and extent of conflict. Promptly submit a written report to Architect.
- E. Survey of Existing Conditions: Record existing conditions by use of measured drawings, preconstruction photographs, preconstruction videotapes and templates.
- F. Perform surveys as the Work progresses to detect hazards resulting from selective demolition activities.

3.2 UTILITY SERVICES AND MECHANICAL/ELECTRICAL SYSTEMS

- A. Existing Services/Systems: Maintain services/systems indicated to remain and protect them against damage during selective demolition operations.
- B. Service/System Requirements: Locate, identify, disconnect, and seal or cap off indicated utility services and mechanical/electrical systems serving areas to be selectively demolished.
 - 1. Arrange to shut off indicated utilities with utility companies.
 - 2. If services/systems are required to be removed, relocated, or abandoned, before proceeding with selective demolition provide temporary services/systems that bypass area of selective demolition and that maintain continuity of services/systems to other parts of building.
 - 3. Cut off pipe or conduit in walls or partitions to be removed. Cap, valve, or plug and seal remaining portion of pipe or conduit after bypassing.

3.3 PREPARATION

- A. Site Access and Temporary Controls: Conduct selective demolition and debris-removal operations to ensure minimum interference with roads, streets, walks, walkways, and other adjacent occupied and used facilities.
- B. Temporary Facilities: Provide temporary barricades and other protection required to prevent injury to people and damage to adjacent buildings and facilities to remain.
- C. Temporary Shoring: Provide and maintain shoring, bracing, and structural supports as required to preserve stability and prevent movement, settlement, or collapse of construction and finishes to remain, and to prevent unexpected or uncontrolled movement or collapse of construction being demolished.

3.4 SELECTIVE DEMOLITION

- A. General: Demolish and remove existing construction only to the extent required by new construction and as indicated. Use methods required to complete the Work within limitations of governing regulations and as follows:
 - 1. Neatly cut openings and holes plumb, square, and true to dimensions required. Use cutting methods least likely to damage construction to remain or adjoining construction. Use hand tools or small power tools designed for sawing or grinding, not hammering and chopping, to minimize disturbance of adjacent surfaces. Temporarily cover openings to remain.
 - 2. Cut or drill from the exposed or finished side into concealed surfaces to avoid marring existing finished surfaces.
 - 3. Do not use cutting torches until work area is cleared of flammable materials. At concealed spaces, such as duct and pipe interiors, verify condition and contents of hidden space before starting flame-cutting operations. Maintain fire watch and portable fire-suppression devices during flame-cutting operations.
 - 4. Locate selective demolition equipment and remove debris and materials so as not to impose excessive loads on supporting walls, floors, or framing.
 - 5. Dispose of demolished items and materials promptly.
- B. Removed and Salvaged Items:

1. Clean salvaged items.
2. Pack or crate items after cleaning. Identify contents of containers.
3. Store items in a secure area until delivery to Owner.
4. Transport items to Owner's storage area designated by Owner.
5. Protect items from damage during transport and storage.

C. Removed and Reinstalled Items:

1. Clean and repair items to functional condition adequate for intended reuse. Paint equipment to match new equipment.
2. Pack or crate items after cleaning and repairing. Identify contents of containers.
3. Protect items from damage during transport and storage.
4. Reinstall items in locations indicated. Comply with installation requirements for new materials and equipment. Provide connections, supports, and miscellaneous materials necessary to make item functional for use indicated.

D. Existing Items to Remain: Protect construction indicated to remain against damage and soiling during selective demolition. When permitted by Architect, items may be removed to a suitable, protected storage location during selective demolition and cleaned and reinstalled in their original locations after selective demolition operations are complete.

3.5 DISPOSAL OF DEMOLISHED MATERIALS

- A. General: Except for items or materials indicated to be recycled or otherwise indicated to remain Owner's property, remove demolished materials from Project site and legally dispose of them in an EPA-approved landfill.
- B. Burning: Do not burn demolished materials.
- C. Disposal: Transport demolished materials off Owner's property and legally dispose of them.

3.6 CLEANING

- A. Clean adjacent structures and improvements of dust, dirt, and debris caused by selective demolition operations. Return adjacent areas to condition existing before selective demolition operations began.

END OF SECTION 02 41 19

SECTION 03 30 00

CAST-IN-PLACE CONCRETE

PART 1 - GENERAL

1.1 RELATED DOCUMENTS

- A. Drawings and general provisions of the Contract, including General and Supplementary Conditions and Division 01 Specification Sections, apply to this Section.

1.2 SUMMARY

- A. Section includes cast-in-place concrete, including formwork, reinforcement, concrete materials, mixture design, placement procedures, and finishes.

1.3 DEFINITIONS

- A. Cementitious Materials: Portland cement alone or in combination with one or more of the following: blended hydraulic cement, fly ash, slag cement, other pozzolans, and silica fume; materials subject to compliance with requirements.
- B. W/C Ratio: The ratio by weight of water to cementitious materials.

1.4 ACTION SUBMITTALS

- A. Product Data: For each type of product.
- B. Design Mixtures: For each concrete mixture. Submit alternate design mixtures when characteristics of materials, Project conditions, weather, test results, or other circumstances warrant adjustments.
 - 1. Indicate amounts of mixing water to be withheld for later addition at Project site.
- C. Steel Reinforcement Shop Drawings: Placing Drawings that detail fabrication, bending, and placement. Include bar sizes, lengths, material, grade, bar schedules, stirrup spacing, bent bar diagrams, bar arrangement, splices and laps, mechanical connections, tie spacing, hoop spacing, and supports for concrete reinforcement.
- D. Construction Joint Layout: Indicate proposed construction joints required to construct the structure.
 - 1. Location of construction joints is subject to approval of the Architect.

1.5 INFORMATIONAL SUBMITTALS

- A. Material Certificates: For each of the following, signed by manufacturers:
1. Cementitious materials.
 2. Admixtures.
 3. Form materials and form-release agents.
 4. Steel reinforcement and accessories.
 5. Fiber reinforcement.
 6. Waterstops.
 7. Curing compounds.
 8. Floor and slab treatments.
 9. Bonding agents.
 10. Adhesives.
 11. Semirigid joint filler.
 12. Joint-filler strips.
 13. Repair materials.
- B. Material Test Reports: For the following, from a qualified testing agency:
1. Aggregates: Include service record data indicating absence of deleterious expansion of concrete due to alkali aggregate reactivity.
- C. Formwork Shop Drawings: Prepared by or under the supervision of a qualified professional engineer, detailing fabrication, assembly, and support of formwork.
1. Shoring and Reshoring: Indicate proposed schedule and sequence of stripping formwork, shoring removal, and reshoring installation and removal.
- D. Floor surface flatness and levelness measurements indicating compliance with specified tolerances.
- E. Field quality-control reports.

1.6 QUALITY ASSURANCE

- A. Manufacturer Qualifications: A firm experienced in manufacturing ready-mixed concrete products and that complies with ASTM C 94/C 94M requirements for production facilities and equipment.
1. Manufacturer certified according to NRMCA's "Certification of Ready Mixed Concrete Production Facilities."
- B. Testing Agency Qualifications: An independent agency qualified according to ASTM C 1077 and ASTM E 329 for testing indicated.
1. Personnel conducting field tests shall be qualified as ACI Concrete Field Testing Technician, Grade 1, according to ACI CP-1 or an equivalent certification program.
 2. Personnel performing laboratory tests shall be ACI-certified Concrete Strength Testing Technician and Concrete Laboratory Testing Technician, Grade I. Testing agency

laboratory supervisor shall be an ACI-certified Concrete Laboratory Testing Technician, Grade II.

- C. Welding Qualifications: Qualify procedures and personnel according to AWS D1.4/D 1.4M.

1.7 PRECONSTRUCTION TESTING

- A. Preconstruction Testing Service: Engage a qualified testing agency to perform preconstruction testing on concrete mixtures.

1.8 DELIVERY, STORAGE, AND HANDLING

- A. Steel Reinforcement: Deliver, store, and handle steel reinforcement to prevent bending and damage. Avoid damaging coatings on steel reinforcement.
- B. Waterstops: Store waterstops under cover to protect from moisture, sunlight, dirt, oil, and other contaminants.

1.9 FIELD CONDITIONS

- A. Cold-Weather Placement: Comply with ACI 306.1 and as follows. Protect concrete work from physical damage or reduced strength that could be caused by frost, freezing actions, or low temperatures.
 - 1. When average high and low temperature is expected to fall below 40 deg F for three successive days, maintain delivered concrete mixture temperature within the temperature range required by ACI 301.
 - 2. Do not use frozen materials or materials containing ice or snow. Do not place concrete on frozen subgrade or on subgrade containing frozen materials.
 - 3. Do not use calcium chloride, salt, or other materials containing antifreeze agents or chemical accelerators unless otherwise specified and approved in mixture designs.
- B. Hot-Weather Placement: Comply with ACI 301 and as follows:
 - 1. Maintain concrete temperature below 90 deg F at time of placement. Chilled mixing water or chopped ice may be used to control temperature, provided water equivalent of ice is calculated to total amount of mixing water. Using liquid nitrogen to cool concrete is Contractor's option.
 - 2. Fog-spray forms, steel reinforcement, and subgrade just before placing concrete. Keep subgrade uniformly moist without standing water, soft spots, or dry areas.

PART 2 - PRODUCTS

2.1 CONCRETE, GENERAL

- A. ACI Publications: Comply with the following unless modified by requirements in the Contract Documents:

1. ACI 301
2. ACI 117

2.2 FORM-FACING MATERIALS

- A. Smooth-Formed Finished Concrete: Form-facing panels that provide continuous, true, and smooth concrete surfaces. Furnish in largest practicable sizes to minimize number of joints.
1. Plywood, metal, or other approved panel materials.
 2. Exterior-grade plywood panels, suitable for concrete forms, complying with DOC PS 1, and as follows:
 - a. High-density overlay, Class 1 or better.
 - b. Medium-density overlay, Class 1 or better; mill-release agent treated and edge sealed.
 - c. Structural 1, B-B or better; mill oiled and edge sealed.
 - d. B-B (Concrete Form), Class 1 or better; mill oiled and edge sealed.
 3. Overlaid Finnish birch plywood.
- B. Forms for Cylindrical Columns, Pedestals, and Supports: Metal, glass-fiber-reinforced plastic, paper, or fiber tubes that produce surfaces with gradual or abrupt irregularities not exceeding specified formwork surface class. Provide units with sufficient wall thickness to resist plastic concrete loads without detrimental deformation.
- C. Chamfer Strips: Wood, metal, PVC, or rubber strips, 3/4 by 3/4 inch, minimum.
- D. Rustication Strips: Wood, metal, PVC, or rubber strips, kerfed for ease of form removal.
- E. Form-Release Agent: Commercially formulated form-release agent that does not bond with, stain, or adversely affect concrete surfaces and does not impair subsequent treatments of concrete surfaces.
1. Formulate form-release agent with rust inhibitor for steel form-facing materials.
- F. Form Ties: Factory-fabricated, removable or snap-off glass-fiber-reinforced plastic or metal form ties designed to resist lateral pressure of fresh concrete on forms and to prevent spalling of concrete on removal.
1. Furnish units that leave no corrodible metal closer than 1 inch to the plane of exposed concrete surface.
 2. Furnish ties that, when removed, leave holes no larger than 1 inch in diameter in concrete surface.
 3. Furnish ties with integral water-barrier plates to walls indicated to receive dampproofing or waterproofing.

2.3 STEEL REINFORCEMENT

- A. Reinforcing Bars: ASTM A 615/A 615M, Grade 60 and Grade 100 as indicated on plans, deformed.

- B. Epoxy-Coated Reinforcing Bars: ASTM A 615/A 615M, Grade 60 deformed bars, epoxy coated, with less than 2 percent damaged coating in each 12-inch bar length.
- C. Deformed-Steel Wire: ASTM A 1064/A 1064M.
- D. Deformed-Steel Welded-Wire Reinforcement: ASTM A 1064/A 1064M, flat sheet.
- E. Galvanized-Steel Welded-Wire Reinforcement: ASTM A 1064/A 1064M, plain, fabricated from galvanized-steel wire into flat sheets.
- F. Epoxy-Coated Welded-Wire Reinforcement: ASTM A 884/A 884M, Class A coated, Type 1, deformed steel.

2.4 REINFORCEMENT ACCESSORIES

- A. Joint Dowel Bars: ASTM A 615/A 615M, Grade 60, plain-steel bars, cut true to length with ends square and free of burrs.
- B. Epoxy-Coated Joint Dowel Bars: ASTM A 615/A 615M, Grade 60, plain-steel bars, ASTM A 775/A 775M epoxy coated.
- C. Epoxy Repair Coating: Liquid, two-part, epoxy repair coating; compatible with epoxy coating on reinforcement and complying with ASTM A 775/A 775M.
- D. Bar Supports: Bolsters, chairs, spacers, and other devices for spacing, supporting, and fastening reinforcing bars and welded-wire reinforcement in place. Manufacture bar supports from steel wire, plastic, or precast concrete according to CRSI's "Manual of Standard Practice," of greater compressive strength than concrete and as follows:
 1. For concrete surfaces exposed to view, where legs of wire bar supports contact forms, use CRSI Class 1 plastic-protected steel wire or CRSI Class 2 stainless-steel bar supports.
 2. For epoxy-coated reinforcement, use epoxy-coated or other dielectric-polymer-coated wire bar supports.
 3. For zinc-coated reinforcement, use galvanized wire or dielectric-polymer-coated wire bar supports.

2.5 CONCRETE MATERIALS

- A. Source Limitations: Obtain each type or class of cementitious material of the same brand from the same manufacturer's plant, obtain aggregate from single source, and obtain admixtures from single source from single manufacturer.
- B. Cementitious Materials:
 1. Portland Cement: ASTM C 150/C 150M.
 2. Fly Ash: ASTM C 618.
 3. Slag Cement: ASTM C 989/C 989M, Grade 100 or 120.
 4. Silica Fume: ASTM C 1240, amorphous silica.

- C. Normal-Weight Aggregates: ASTM C 33/C 33M, coarse aggregate or better, graded. Provide aggregates from a single source with documented service record data of at least 10 years' satisfactory service in similar applications and service conditions using similar aggregates and cementitious materials.
 - 1. Maximum Coarse-Aggregate Size: 1 inch nominal.
 - 2. Fine Aggregate: Free of materials with deleterious reactivity to alkali in cement.
- D. Air-Entraining Admixture: ASTM C 260/C 260M.
- E. Chemical Admixtures: Certified by manufacturer to be compatible with other admixtures and that do not contribute water-soluble chloride ions exceeding those permitted in hardened concrete. Do not use calcium chloride or admixtures containing calcium chloride.
 - 1. Water-Reducing Admixture: ASTM C 494/C 494M, Type A.
 - 2. Retarding Admixture: ASTM C 494/C 494M, Type B.
 - 3. Water-Reducing and Retarding Admixture: ASTM C 494/C 494M, Type D.
 - 4. High-Range, Water-Reducing Admixture: ASTM C 494/C 494M, Type F.
 - 5. High-Range, Water-Reducing and Retarding Admixture: ASTM C 494/C 494M, Type G.
 - 6. Plasticizing and Retarding Admixture: ASTM C 1017/C 1017M, Type II.
- F. Set-Accelerating Corrosion-Inhibiting Admixture: Commercially formulated, anodic inhibitor or mixed cathodic and anodic inhibitor; capable of forming a protective barrier and minimizing chloride reactions with steel reinforcement in concrete and complying with ASTM C 494/C 494M, Type C.
- G. Non-Set-Accelerating Corrosion-Inhibiting Admixture: Commercially formulated, non-set-accelerating, anodic inhibitor or mixed cathodic and anodic inhibitor; capable of forming a protective barrier and minimizing chloride reactions with steel reinforcement in concrete.
- H. Water: ASTM C 94/C 94M and potable.
- I. Foam Board Insulation: ASTM C 578 and ASTM C518
 - 1. Provide exterior insulation board labeled with manufacturer's name, product name, ASTM spec reference, and compressive strength.
 - 2. Extruded Polystyrene Board Insulation: Comply with ASTM C 578, Type V, 100 psi compressive strength, 3.00 lb/cu. ft. (48 kg/cu. m).
 - a. Thermal Resistance: (180 day real-time aging as mandated by ASTM C578, measured per ASTM C 518 at mean temperature of 75F): R-5.6 per inch of thickness, with 90% lifetime limited warranty on thermal resistance.
 - b. Blowing Agent Formulation: Zero ozone depleting.
 - c. Edge Condition: Square.
 - d. Recycled Content: Minimum 20%, certified by independent third party such as Scientific Certification Systems.
 - e. Warranty: Limited lifetime warranty covering all ASTM C578 physical properties.
 - f. Panel Size: Provide 1" or 2" thicknesses by 4 ft. wide by 8 ft. long.

2.6 FIBER REINFORCEMENT

- A. Synthetic Macro-Fiber: Polyolefin macro-fibers engineered and designed for use in concrete, complying with ASTM C 1116/C 1116M, Type III, 2-1/4 inches long.

2.7 WATERSTOPS

- A. Self-Expanding Butyl Strip Waterstops: Manufactured rectangular or trapezoidal strip, butyl rubber with sodium bentonite or other hydrophilic polymers, for adhesive bonding to concrete, 3/4 by 1 inch.

2.8 FLOOR AND SLAB TREATMENTS

- A. Exterior densifier: Water based, VOC Compliant slab treatment.
 - 1. Pentra-Hard EDH by Dayton Superior or approved equal.

2.9 CURING MATERIALS

- A. Evaporation Retarder: Waterborne, monomolecular film forming, manufactured for application to fresh concrete.
- B. Absorptive Cover: AASHTO M 182, Class 2, burlap cloth made from jute or kenaf, weighing approximately 9 oz./sq. yd. (305 g/sq. m) when dry.
- C. Moisture-Retaining Cover: ASTM C 171, polyethylene film or white burlap-polyethylene sheet.
- D. Water: Potable.
- E. Clear, Waterborne, Membrane-Forming Curing Compound: ASTM C 309, Type 1, Class B, dissipating.

2.10 RELATED MATERIALS

- A. Expansion- and Isolation-Joint-Filler Strips: ASTM D 1751, asphalt-saturated cellulosic fiber.
- B. Semirigid Joint Filler: Two-component, semirigid, 100 percent solids, according to ASTM D 2240.
- C. Bonding Agent: ASTM C 1059/C 1059M, Type II, nonredispersible, acrylic emulsion or styrene butadiene.
- D. Epoxy Bonding Adhesive: ASTM C 881, two-component epoxy resin, capable of humid curing and bonding to damp surfaces, of class suitable for application temperature and of grade to suit requirements, and as follows:
 - 1. Types I and II, nonload bearing or Types IV and V, load bearing, for bonding hardened or freshly mixed concrete to hardened concrete.

2.11 CONCRETE MIXTURES, GENERAL

- A. Prepare design mixtures for each type and strength of concrete, proportioned on the basis of laboratory trial mixture or field test data, or both, according to ACI 301.
 - 1. Use a qualified independent testing agency for preparing and reporting proposed mixture designs based on laboratory trial mixtures.
- B. Cementitious Materials: Use fly ash, pozzolan, slag cement, and silica fume as needed to reduce the total amount of portland cement, which would otherwise be used, by not less than 40 percent. Limit percentage, by weight, of cementitious materials other than portland cement in concrete as follows:
 - 1. Fly Ash: 25 percent.
 - 2. Combined Fly Ash and Pozzolan: 25 percent.
 - 3. Slag Cement: 50 percent.
 - 4. Combined Fly Ash or Pozzolan and Slag Cement: 50 percent portland cement minimum, with fly ash or pozzolan not exceeding 25 percent.
 - 5. Silica Fume: 10 percent.
 - 6. Combined Fly Ash, Pozzolans, and Silica Fume: 35 percent with fly ash or pozzolans not exceeding 25 percent and silica fume not exceeding 10 percent.
 - 7. Combined Fly Ash or Pozzolans, Slag Cement, and Silica Fume: 50 percent with fly ash or pozzolans not exceeding 25 percent and silica fume not exceeding 10 percent.
- C. Limit water-soluble, chloride-ion content in hardened concrete to 0.06 percent by weight of cement.
- D. Admixtures: Use admixtures according to manufacturer's written instructions.
 - 1. Use water-reducing, high-range water-reducing, or plasticizing admixture in concrete, as required, for placement and workability.
 - 2. Use water-reducing and -retarding admixture when required by high temperatures, low humidity, or other adverse placement conditions.
 - 3. Use water-reducing admixture in pumped concrete, concrete for heavy-use industrial slabs and parking structure slabs, concrete required to be watertight, and concrete with a w/c ratio below 0.50.
 - 4. Use corrosion-inhibiting admixture in concrete mixtures where indicated.

2.12 CONCRETE MIXTURES FOR BUILDING ELEMENTS

- A. Footings and Foundation Walls: Normal-weight concrete.
 - 1. Minimum Compressive Strength: As indicated at 28 days.
 - 2. Maximum W/C Ratio: 0.50.
 - 3. Slump Limit: 6 inches for concrete with verified slump of 2 to 4 inches before adding high-range water-reducing admixture or plasticizing admixture.
 - 4. Air Content: 6 percent, plus or minus 1.5 percent at point of delivery for 3/4-inch nominal maximum aggregate size.
- B. Slabs-on-Grade, Roof slab: Normal-weight concrete.

1. Minimum Compressive Strength: As indicated at 28 days.
2. Maximum W/C Ratio: 0.43.
3. 8/18 gradation of combined aggregate.
4. 1 ½" nominal maximum aggregate size.
5. Minimum Cementitious Materials Content: 510 lb/cu. yd.
6. Slump Limit: 6 inches plus for concrete with verified slump of 2 to 4 inches before adding high-range water-reducing admixture or plasticizing admixture.
7. Air Content: 6 percent, plus 0 and minus 1.5 percent at point of delivery.
8. Synthetic Macro-Fiber: Uniformly disperse in concrete mixture at manufacturer's recommended rate, but not less than a rate of 5.0 lb/cu. yd.

C. Columns: Normal-weight concrete.

1. Minimum Compressive Strength: 6000 psi at 28 days.
2. Maximum W/C Ratio: 0.45.
3. Slump Limit: 7 inches for concrete with verified slump of 2 to 4 inches before adding high-range water-reducing admixture or plasticizing admixture.
4. Air Content: 6 percent, plus 0, minus 1.5 percent at point of delivery for ¾ inch nominal maximum aggregate size.

2.13 FABRICATING REINFORCEMENT

- A. Fabricate steel reinforcement according to CRSI's "Manual of Standard Practice."

2.14 CONCRETE MIXING

- A. Ready-Mixed Concrete: Measure, batch, mix, and deliver concrete according to ASTM C 94/C 94M and ASTM C 1116/C 1116M, and furnish batch ticket information.
1. When air temperature is between 85 and 90 deg F, reduce mixing and delivery time from 1-1/2 hours to 75 minutes; when air temperature is above 90 deg F, reduce mixing and delivery time to 60 minutes.

PART 3 - EXECUTION

3.1 FORMWORK INSTALLATION

- A. Design, erect, shore, brace, and maintain formwork, according to ACI 301, to support vertical, lateral, static, and dynamic loads, and construction loads that might be applied, until structure can support such loads.
- B. Construct formwork so concrete members and structures are of size, shape, alignment, elevation, and position indicated, within tolerance limits of ACI 117.
- C. Limit concrete surface irregularities, designated by ACI 347 as abrupt or gradual, as follows:

1. Class A, 1/8 inch for smooth-formed finished surfaces exposed to view.
 2. Class B, 1/4 inch for rough-formed finished surfaces not exposed to view.
- D. Construct forms tight enough to prevent loss of concrete mortar.
- E. Construct forms for easy removal without hammering or prying against concrete surfaces. Provide crush or wrecking plates where stripping may damage cast-concrete surfaces. Provide top forms for inclined surfaces steeper than 1.5 horizontal to 1 vertical.
1. Install keyways, reglets, recesses, and the like, for easy removal.
 2. Do not use rust-stained steel form-facing material.
- F. Set edge forms, bulkheads, and intermediate screed strips for slabs to achieve required elevations and slopes in finished concrete surfaces. Provide and secure units to support screed strips; use strike-off templates or compacting-type screeds.
- G. Provide temporary openings for cleanouts and inspection ports where interior area of formwork is inaccessible. Close openings with panels tightly fitted to forms and securely braced to prevent loss of concrete mortar. Locate temporary openings in forms at inconspicuous locations.
- H. Chamfer exterior corners and edges of permanently exposed concrete.
- I. Form openings, chases, offsets, sinkages, keyways, reglets, blocking, screeds, and bulkheads required in the Work. Determine sizes and locations from trades providing such items.
- J. Clean forms and adjacent surfaces to receive concrete. Remove chips, wood, sawdust, dirt, and other debris just before placing concrete.
- K. Retighten forms and bracing before placing concrete, as required, to prevent mortar leaks and maintain proper alignment.
- L. Coat contact surfaces of forms with form-release agent, according to manufacturer's written instructions, before placing reinforcement.

3.2 EMBEDDED ITEM INSTALLATION

- A. Place and secure anchorage devices and other embedded items required for adjoining work that is attached to or supported by cast-in-place concrete. Use setting drawings, templates, diagrams, instructions, and directions furnished with items to be embedded.
1. Install anchor rods, accurately located, to elevations required and complying with tolerances in Section 7.5 of AISC 303.
 2. Install reglets to receive waterproofing and to receive through-wall flashings in outer face of concrete frame at exterior walls, where flashing is shown at lintels, shelf angles, and other conditions.
 3. Install dovetail anchor slots in concrete structures as indicated.

3.3 REMOVING AND REUSING FORMS

- A. General: Formwork for sides of beams, walls, columns, and similar parts of the Work that does not support weight of concrete may be removed after cumulatively curing at not less than 50 deg F for 24 hours after placing concrete. Concrete has to be hard enough to not be damaged by form-removal operations, and curing and protection operations need to be maintained.
 - 1. Leave formwork for beam soffits, joists, slabs, and other structural elements that support weight of concrete in place until concrete has achieved at least 70 percent of its 28-day design compressive strength.
 - 2. Remove forms only if shores have been arranged to permit removal of forms without loosening or disturbing shores.
- B. Clean and repair surfaces of forms to be reused in the Work. Split, frayed, delaminated, or otherwise damaged form-facing material are not acceptable for exposed surfaces. Apply new form-release agent.
- C. When forms are reused, clean surfaces, remove fins and laitance, and tighten to close joints. Align and secure joints to avoid offsets. Do not use patched forms for exposed concrete surfaces unless approved by Architect.

3.4 SHORING AND RESHORING INSTALLATION

- A. Comply with ACI 318 and ACI 301 for design, installation, and removal of shoring and reshoring.
 - 1. Do not remove shoring or reshoring until measurement of slab tolerances is complete.
- B. In multistory construction, extend shoring or reshoring over a sufficient number of stories to distribute loads in such a manner that no floor or member will be excessively loaded or will induce tensile stress in concrete members without sufficient steel reinforcement.
- C. Plan sequence of removal of shores and reshore to avoid damage to concrete. Locate and provide adequate reshoring to support construction without excessive stress or deflection.

3.5 STEEL REINFORCEMENT INSTALLATION

- A. General: Comply with CRSI's "Manual of Standard Practice" for fabricating, placing, and supporting reinforcement.
 - 1. Do not cut or puncture vapor retarder. Repair damage and reseal vapor retarder before placing concrete.
- B. Clean reinforcement of loose rust and mill scale, earth, ice, and other foreign materials that reduce bond to concrete.
- C. Accurately position, support, and secure reinforcement against displacement. Locate and support reinforcement with bar supports to maintain minimum concrete cover. Do not tack weld crossing reinforcing bars.

1. Weld reinforcing bars according to AWS D1.4/D 1.4M, where indicated.
- D. Set wire ties with ends directed into concrete, not toward exposed concrete surfaces.
- E. Install welded-wire reinforcement in longest practicable lengths on bar supports spaced to minimize sagging. Lap edges and ends of adjoining sheets at least one mesh spacing. Offset laps of adjoining sheet widths to prevent continuous laps in either direction. Lace overlaps with wire.
- F. Epoxy-Coated Reinforcement: Repair cut and damaged epoxy coatings with epoxy repair coating according to ASTM D 3963/D 3963M. Use epoxy-coated steel wire ties to fasten epoxy-coated steel reinforcement.
- G. Zinc-Coated Reinforcement: Repair cut and damaged zinc coatings with zinc repair material according to ASTM A 780/A 780M. Use galvanized-steel wire ties to fasten zinc-coated steel reinforcement.

3.6 JOINTS

- A. General: Construct joints true to line with faces perpendicular to surface plane of concrete.
- B. Construction Joints: Install so strength and appearance of concrete are not impaired, at locations indicated or as approved by Architect.
 1. Place joints perpendicular to main reinforcement. Continue reinforcement across construction joints unless otherwise indicated. Do not continue reinforcement through sides of strip placements of floors and slabs.
 2. Form keyed joints as indicated. Embed keys at least 1-1/2 inches into concrete.
 3. Locate joints for beams, slabs, joists, and girders in the middle third of spans. Offset joints in girders a minimum distance of twice the beam width from a beam-girder intersection.
 4. Locate horizontal joints in walls and columns at underside of floors, slabs, beams, and girders and at the top of footings or floor slabs.
 5. Space vertical joints in walls at 3 times wall height. Locate joints beside piers integral with walls, near corners, and in concealed locations where possible.
 6. Use a bonding agent at locations where fresh concrete is placed against hardened or partially hardened concrete surfaces.
 7. Use epoxy-bonding adhesive at locations where fresh concrete is placed against hardened or partially hardened concrete surfaces.
- C. Contraction Joints in Slabs-on-Grade: Form weakened-plane contraction joints, sectioning concrete into areas as indicated. Construct contraction joints for a depth equal to at least one-fourth of concrete thickness as follows:
 1. Sawed Joints: Form contraction joints with power saws equipped with shatterproof abrasive or diamond-rimmed blades. Cut 1/8-inch wide joints into concrete when cutting action does not tear, abrade, or otherwise damage surface and before concrete develops random contraction cracks.
- D. Isolation Joints in Slabs-on-Grade: After removing formwork, install joint-filler strips at slab junctions with vertical surfaces, such as column pedestals, foundation walls, grade beams, and other locations, as indicated.

1. Extend joint-filler strips full width and depth of joint, terminating flush with finished concrete surface unless otherwise indicated.
 2. Terminate full-width joint-filler strips not less than 1/2 inch or more than 1 inch below finished concrete surface where joint sealants, specified in Section 079200 "Joint Sealants," are indicated.
 3. Install joint-filler strips in lengths as long as practicable. Where more than one length is required, lace or clip sections together.
- E. Doweled Joints: Install dowel bars and support assemblies at joints where indicated. Lubricate or asphalt coat one-half of dowel length to prevent concrete bonding to one side of joint.

3.7 WATERSTOP INSTALLATION

- A. Self-Expanding Strip Waterstops: Install in construction joints and at other locations indicated, according to manufacturer's written instructions, adhesive bonding, mechanically fastening, and firmly pressing into place. Install in longest lengths practicable.

3.8 CONCRETE PLACEMENT

- A. Before placing concrete, verify that installation of formwork, reinforcement, and embedded items is complete and that required inspections are completed.
- B. Do not add water to concrete during delivery, at Project site, or during placement unless approved by Engineer.
- C. Deposit concrete continuously in one layer or in horizontal layers of such thickness that no new concrete is placed on concrete that has hardened enough to cause seams or planes of weakness. If a section cannot be placed continuously, provide construction joints as indicated. Deposit concrete to avoid segregation.
1. Deposit concrete in horizontal layers of depth not to exceed formwork design pressures and in a manner to avoid inclined construction joints.
 2. Consolidate placed concrete with mechanical vibrating equipment according to ACI 301
 3. Do not use vibrators to transport concrete inside forms. Insert and withdraw vibrators vertically at uniformly spaced locations to rapidly penetrate placed layer and at least 6 inches into preceding layer. Do not insert vibrators into lower layers of concrete that have begun to lose plasticity. At each insertion, limit duration of vibration to time necessary to consolidate concrete and complete embedment of reinforcement and other embedded items without causing mixture constituents to segregate.
- D. Deposit and consolidate concrete for floors and slabs in a continuous operation, within limits of construction joints, until placement of a panel or section is complete.
1. Consolidate concrete during placement operations, so concrete is thoroughly worked around reinforcement and other embedded items and into corners.
 2. Maintain reinforcement in position on chairs during concrete placement.
 3. Screed slab surfaces with a straightedge and strike off to correct elevations.
 4. Slope surfaces uniformly to drains where required.

5. Begin initial floating using bull floats or darbies to form a uniform and open-textured surface plane, before excess bleedwater appears on the surface. Do not further disturb slab surfaces before starting finishing operations.

3.9 FINISHING FORMED SURFACES

- A. Rough-Formed Finish: As-cast concrete texture imparted by form-facing material with tie holes and defects repaired and patched. Remove fins and other projections that exceed specified limits on formed-surface irregularities.
 1. Apply to concrete surfaces not exposed to public view.
- B. Smooth-Formed Finish: As-cast concrete texture imparted by form-facing material, arranged in an orderly and symmetrical manner with a minimum of seams. Repair and patch tie holes and defects. Remove fins and other projections that exceed specified limits on formed-surface irregularities.
 1. Apply to concrete surfaces exposed to public view
- C. Related Unformed Surfaces: At tops of walls, horizontal offsets, and similar unformed surfaces adjacent to formed surfaces, strike off smooth and finish with a texture matching adjacent formed surfaces. Continue final surface treatment of formed surfaces uniformly across adjacent unformed surfaces unless otherwise indicated.

3.10 FINISHING FLOORS AND SLABS

- A. General: Comply with ACI 302.1R recommendations for screeding, restraighening, and finishing operations for concrete surfaces. Do not wet concrete surfaces.
- B. Float Finish: Consolidate surface with power-driven floats or by hand floating if area is small or inaccessible to power-driven floats. Restraighten, cut down high spots, and fill low spots. Repeat float passes and restraighening until surface is left with a uniform, smooth, granular texture.
- C. Trowel Finish: After applying float finish, apply first troweling and consolidate concrete by hand or power-driven trowel. Continue troweling passes and restraighten until surface is free of trowel marks and uniform in texture and appearance. Grind smooth any surface defects that would telegraph through applied coatings or floor coverings.
 1. Apply a trowel finish to surfaces .
 2. Finish surfaces to the following tolerances, according to ASTM E 1155, for a randomly trafficked floor surface:
 - a. Specified overall values of flatness, F(F) 25; and of levelness, F(L) 20; with minimum local values of flatness, F(F) 17; and of levelness, F(L) 15.
- D. Trowel and Fine-Broom Finish: Apply a first trowel finish to surfaces. While concrete is still plastic, slightly scarify surface with a fine broom.
 1. Comply with flatness and levelness tolerances for trowel-finished floor surfaces.

3.11 MISCELLANEOUS CONCRETE ITEM INSTALLATION

- A. Filling In: Fill in holes and openings left in concrete structures after work of other trades is in place unless otherwise indicated. Mix, place, and cure concrete, as specified, to blend with in-place construction. Provide other miscellaneous concrete filling indicated or required to complete the Work.

3.12 CONCRETE PROTECTING AND CURING

- A. General: Protect freshly placed concrete from premature drying and excessive cold or hot temperatures. Comply with ACI 306.1 for cold-weather protection and ACI 301 for hot-weather protection during curing.
- B. Evaporation Retarder: Apply evaporation retarder to unformed concrete surfaces if hot, dry, or windy conditions cause moisture loss approaching 0.2 lb/sq. ft. x h before and during finishing operations. Apply according to manufacturer's written instructions after placing, screeding, and bull floating or darbying concrete, but before float finishing.
- C. Formed Surfaces: Cure formed concrete surfaces, including underside of beams, supported slabs, and other similar surfaces. If forms remain during curing period, moist cure after loosening forms. If removing forms before end of curing period, continue curing for remainder of curing period.
- D. Unformed Surfaces: Begin curing immediately after finishing concrete. Cure unformed surfaces, including floors and slabs, concrete floor toppings, and other surfaces.
- E. Cure concrete according to ACI 308.1, by one or a combination of the following methods:
 - 1. Moisture Curing: Keep surfaces continuously moist for not less than seven days with the following materials:
 - a. Water.
 - b. Continuous water-fog spray.
 - c. Absorptive cover, water saturated, and kept continuously wet. Cover concrete surfaces and edges with 12-inch lap over adjacent absorptive covers.
 - 2. Moisture-Retaining-Cover Curing: Cover concrete surfaces with moisture-retaining cover for curing concrete, placed in widest practicable width, with sides and ends lapped at least 12 inches, and sealed by waterproof tape or adhesive. Cure for not less than seven days. Immediately repair any holes or tears during curing period, using cover material and waterproof tape.
 - a. Moisture cure or use moisture-retaining covers to cure concrete surfaces to receive floor coverings.
 - b. Moisture cure or use moisture-retaining covers to cure concrete surfaces to receive penetrating liquid floor treatments.
 - c. Cure concrete surfaces to receive floor coverings with either a moisture-retaining cover or a curing compound that the manufacturer certifies does not interfere with bonding of floor covering used on Project.

3. Curing Compound: Apply uniformly in continuous operation by power spray or roller according to manufacturer's written instructions. Recoat areas subjected to heavy rainfall within three hours after initial application. Maintain continuity of coating and repair damage during curing period.
 - a. Removal: After curing period has elapsed, remove curing compound without damaging concrete surfaces by method recommended by curing compound manufacturer.
4. Curing and Sealing Compound: Apply uniformly to floors and slabs indicated in a continuous operation by power spray or roller according to manufacturer's written instructions. Recoat areas subjected to heavy rainfall within three hours after initial application. Repeat process 24 hours later and apply a second coat. Maintain continuity of coating and repair damage during curing period.

3.13 LIQUID FLOOR TREATMENT APPLICATION

- A. Penetrating Liquid Floor Treatment: Prepare, apply, and finish penetrating liquid floor treatment according to manufacturer's written instructions.
 1. Remove curing compounds, sealers, oil, dirt, laitance, and other contaminants and complete surface repairs.
 2. Do not apply to concrete that is less than 14 days' old.
 3. Apply liquid until surface is saturated, scrubbing into surface until a gel forms; rewet; and repeat brooming or scrubbing. Rinse with water; remove excess material until surface is dry. Apply a second coat in a similar manner if surface is rough or porous.
- B. Sealing Coat: Uniformly apply a continuous sealing coat of curing and sealing compound to hardened concrete by power spray or roller according to manufacturer's written instructions.

3.14 JOINT FILLING

- A. Prepare, clean, and install joint filler according to manufacturer's written instructions.
 1. Defer joint filling until concrete has aged at least one month(s). Do not fill joints until construction traffic has permanently ceased.
- B. Remove dirt, debris, saw cuttings, curing compounds, and sealers from joints; leave contact faces of joints clean and dry.
- C. Install semirigid joint filler full depth in saw-cut joints and at least 2 inches deep in formed joints. Overfill joint and trim joint filler flush with top of joint after hardening.

3.15 CONCRETE SURFACE REPAIRS

- A. Defective Concrete: Repair and patch defective areas when approved by Architect. Remove and replace concrete that cannot be repaired and patched to Architect's approval.

- B. Patching Mortar: Mix dry-pack patching mortar, consisting of 1 part portland cement to 2-1/2 parts fine aggregate passing a No. 16 sieve, using only enough water for handling and placing.
- C. Repairing Formed Surfaces: Surface defects include color and texture irregularities, cracks, spalls, air bubbles, honeycombs, rock pockets, fins and other projections on the surface, and stains and other discolorations that cannot be removed by cleaning.
1. Immediately after form removal, cut out honeycombs, rock pockets, and voids more than 1/2 inch in any dimension to solid concrete. Limit cut depth to 3/4 inch. Make edges of cuts perpendicular to concrete surface. Clean, dampen with water, and brush-coat holes and voids with bonding agent. Fill and compact with patching mortar before bonding agent has dried. Fill form-tie voids with patching mortar or cone plugs secured in place with bonding agent.
 2. Repair defects on surfaces exposed to view by blending white portland cement and standard portland cement so that, when dry, patching mortar matches surrounding color. Patch a test area at inconspicuous locations to verify mixture and color match before proceeding with patching. Compact mortar in place and strike off slightly higher than surrounding surface.
 3. Repair defects on concealed formed surfaces that affect concrete's durability and structural performance as determined by Architect.
- D. Repairing Unformed Surfaces: Test unformed surfaces, such as floors and slabs, for finish and verify surface tolerances specified for each surface. Correct low and high areas. Test surfaces sloped to drain for trueness of slope and smoothness; use a sloped template.
1. Repair finished surfaces containing defects. Surface defects include spalls, popouts, honeycombs, rock pockets, crazing and cracks in excess of 0.01 inch wide or that penetrate to reinforcement or completely through unreinforced sections regardless of width, and other objectionable conditions.
 2. After concrete has cured at least 14 days, correct high areas by grinding.
 3. Correct localized low areas during or immediately after completing surface finishing operations by cutting out low areas and replacing with patching mortar. Finish repaired areas to blend into adjacent concrete.
 4. Correct other low areas scheduled to receive floor coverings with a repair underlayment. Prepare, mix, and apply repair underlayment and primer according to manufacturer's written instructions to produce a smooth, uniform, plane, and level surface. Feather edges to match adjacent floor elevations.
 5. Correct other low areas scheduled to remain exposed with a repair topping. Cut out low areas to ensure a minimum repair topping depth of 1/4 inch to match adjacent floor elevations. Prepare, mix, and apply repair topping and primer according to manufacturer's written instructions to produce a smooth, uniform, plane, and level surface.
 6. Repair defective areas, except random cracks and single holes 1 inch or less in diameter, by cutting out and replacing with fresh concrete. Remove defective areas with clean, square cuts and expose steel reinforcement with at least a 3/4-inch clearance all around. Dampen concrete surfaces in contact with patching concrete and apply bonding agent. Mix patching concrete of same materials and mixture as original concrete, except without coarse aggregate. Place, compact, and finish to blend with adjacent finished concrete. Cure in same manner as adjacent concrete.
 7. Repair random cracks and single holes 1 inch or less in diameter with patching mortar. Groove top of cracks and cut out holes to sound concrete and clean off dust, dirt, and loose particles. Dampen cleaned concrete surfaces and apply bonding agent. Place

patching mortar before bonding agent has dried. Compact patching mortar and finish to match adjacent concrete. Keep patched area continuously moist for at least 72 hours.

- E. Perform structural repairs of concrete, subject to Architect's approval, using epoxy adhesive and patching mortar.
- F. Repair materials and installation not specified above may be used, subject to Architect's approval.

3.16 FIELD QUALITY CONTROL

- A. Special Inspections: Owner will engage a qualified testing and inspecting agency to perform field tests and inspections and prepare test reports.
- B. Testing Agency: Engage a qualified testing and inspecting agency to perform tests and inspections and to submit reports.
- C. Inspections:
 - 1. Steel reinforcement placement.
 - 2. Steel reinforcement welding.
 - 3. Headed bolts and studs.
 - 4. Verification of use of required design mixture.
 - 5. Concrete placement, including conveying and depositing.
 - 6. Curing procedures and maintenance of curing temperature.
 - 7. Verification of concrete strength before removal of shores and forms from beams and slabs.
- D. Concrete Tests: Testing of composite samples of fresh concrete obtained according to ASTM C 172/C 172M shall be performed according to the following requirements:
 - 1. Testing Frequency: Obtain one composite sample for each day's pour of each concrete mixture exceeding 5 cu. yd., but less than 25 cu. yd., plus one set for each additional 50 cu. yd. or fraction thereof.
 - 2. Testing Frequency: Obtain at least one composite sample for each 100 cu. yd. or fraction thereof of each concrete mixture placed each day.
 - a. When frequency of testing provides fewer than five compressive-strength tests for each concrete mixture, testing shall be conducted from at least five randomly selected batches or from each batch if fewer than five are used.
 - 3. Slump: ASTM C 143/C 143M; one test at point of placement for each composite sample, but not less than one test for each day's pour of each concrete mixture. Perform additional tests when concrete consistency appears to change.
 - 4. Air Content: ASTM C 231/C 231M, pressure method, for normal-weight concrete; one test for each composite sample, but not less than one test for each day's pour of each concrete mixture.
 - 5. Concrete Temperature: ASTM C 1064/C 1064M; one test hourly when air temperature is 40 deg F and below or 80 deg F and above, and one test for each composite sample.

6. Unit Weight: ASTM C 567/C 567M, fresh unit weight of structural lightweight concrete; one test for each composite sample, but not less than one test for each day's pour of each concrete mixture.
 7. Compression Test Specimens: ASTM C 31/C 31M.
 - a. Cast and field cure two sets of two standard cylinder specimens for each composite sample.
 8. Compressive-Strength Tests: ASTM C 39/C 39M; test one set of two laboratory-cured specimens at 7 days and one set of two specimens at 28 days.
 - a. Test one set of two field-cured specimens at 7 days and one set of two specimens at 28 days.
 - b. A compressive-strength test shall be the average compressive strength from a set of two specimens obtained from same composite sample and tested at age indicated.
 9. When strength of field-cured cylinders is less than 85 percent of companion laboratory-cured cylinders, Contractor shall evaluate operations and provide corrective procedures for protecting and curing in-place concrete.
 10. Strength of each concrete mixture will be satisfactory if every average of any three consecutive compressive-strength tests equals or exceeds specified compressive strength and no compressive-strength test value falls below specified compressive strength by more than 500 psi.
 11. Test results shall be reported in writing to Architect, concrete manufacturer, and Contractor within 48 hours of testing. Reports of compressive-strength tests shall contain Project identification name and number, date of concrete placement, name of concrete testing and inspecting agency, location of concrete batch in Work, design compressive strength at 28 days, concrete mixture proportions and materials, compressive breaking strength, and type of break for both 7- and 28-day tests.
 12. Nondestructive Testing: Impact hammer, sonoscope, or other nondestructive device may be permitted by Architect but will not be used as sole basis for approval or rejection of concrete.
 13. Additional Tests: Testing and inspecting agency shall make additional tests of concrete when test results indicate that slump, air entrainment, compressive strengths, or other requirements have not been met, as directed by Architect. Testing and inspecting agency may conduct tests to determine adequacy of concrete by cored cylinders complying with ASTM C 42/C 42M or by other methods as directed by Architect.
 14. Additional testing and inspecting, at Contractor's expense, will be performed to determine compliance of replaced or additional work with specified requirements.
 15. Correct deficiencies in the Work that test reports and inspections indicate do not comply with the Contract Documents.
- E. Measure floor and slab flatness and levelness according to ASTM E 115 within 48 hours of finishing.

END OF SECTION 03 30 00

Page Intentionally Left Blank

SECTION 05 50 00

METAL FABRICATIONS

PART 1 - GENERAL

1.1 SUMMARY

- A. This Section includes the following:
 - 1. Leveling dock, galvanized steel angles for casting into concrete.
 - 2. Metal bollards.
 - 3. Metal guard rails.
 - 4. Metal Jambs and Header at High Speed Roll-up Door.
 - 5. Metal Dock Leveler Controller Posts.

1.2 PERFORMANCE REQUIREMENTS

- A. Thermal Movements: Provide exterior metal fabrications that allow for thermal movements resulting from the following maximum change (range) in ambient and surface temperatures by preventing buckling, opening of joints, overstressing of components, failure of connections, and other detrimental effects. Base engineering calculation on surface temperatures of materials due to both solar heat gain and nighttime-sky heat loss.
 - 1. Temperature Change (Range): 120 deg F, ambient; 180 deg F, material surfaces.

1.3 SUBMITTALS

- A. Shop Drawings: Show fabrication and installation details for metal fabrications.
 - 1. Include plans, elevations, sections, and details of metal fabrications and their connections. Show anchorage and accessory items.
 - 2. Provide templates for anchors and bolts specified for installation under other Sections.

1.4 QUALITY ASSURANCE

- A. Welding: Qualify procedures and personnel according to the following:
 - 1. AWS D1.1, "Structural Welding Code--Steel."
 - 2. AWS D1.3, "Structural Welding Code--Sheet Steel."

1.5 PROJECT CONDITIONS

- A. Field Measurements: Verify actual locations of walls and other construction contiguous with metal fabrications by field measurements before fabrication and indicate measurements on Shop Drawings.

1. Established Dimensions: Where field measurements cannot be made without delaying the Work, establish dimensions and proceed with fabricating metal fabrications without field measurements. Coordinate wall and other contiguous construction to ensure that actual dimensions correspond to established dimensions.
2. Provide allowance for trimming and fitting at site.

1.6 COORDINATION

- A. Coordinate installation of anchorages for metal fabrications. Furnish setting drawings, templates, and directions for installing anchorages, including sleeves, concrete inserts, anchor bolts, and items with integral anchors, that are to be embedded in concrete or masonry. Deliver such items to Project site in time for installation.
- B. Coordinate installation of steel weld plates and angles for casting into concrete that are specified in this Section but required for work of another Section. Deliver such items to Project site in time for installation.

PART 2 - PRODUCTS

2.1 METALS

- A. Metal Surfaces, General: Provide materials with smooth, flat surfaces, unless otherwise indicated. For metal fabrications exposed to view in the completed Work, provide materials without seam marks, roller marks, rolled trade names, or blemishes.
- B. Recycled Content of Steel Products: Postconsumer recycled content plus one-half of preconsumer recycled content not less than 25 percent.
- C. Steel Plates, Shapes, and Bars: ASTM A 36/A 36M.
- D. Steel Tubing: ASTM A 500, cold-formed steel tubing.
- E. Steel Pipe: ASTM A 53/A 53M, standard weight (Schedule 40), unless another weight is indicated or required by structural loads.
- F. Carbon Steel: AISI 1010/15 per ASTM A 569/A 1011 grade 36 or higher.
- G. Stainless Steel: AISI 304.
- H. Castings: Either gray or malleable iron unless otherwise noted.
 1. Gray Iron: ASTM A 48/A 48M, Class 30.
 2. Malleable Iron: ASTM A 47/A 47M.
- I. Bronze Plate, Sheet, Strip, and Bars: ASTM B 36/B 36M, Alloy UNS No. C28000 (muntz metal, 60 percent copper).
- J. Nickel Silver Extrusions: ASTM B 151/B 151M, Alloy UNS No. C74500.

2.2 FASTENERS

- A. General: Unless otherwise indicated, provide Type 304 stainless-steel fasteners for exterior use and zinc-plated fasteners with coating complying with ASTM B 633, Class Fe/Zn 5, at exterior walls. Provide stainless-steel fasteners for fastening aluminum. Select fasteners for type, grade, and class required.
- B. Cast-in-Place Anchors in Concrete: Either threaded type or wedge type unless otherwise indicated; galvanized ferrous castings, either ASTM A 47/A 47M malleable iron or ASTM A 27/A 27M cast steel. Provide bolts, washers, and shims as needed, all hot-dip galvanized per ASTM F 2329.
- C. Slotted-Channel Inserts: Cold-formed, hot-dip galvanized-steel box channels (struts) complying with MFMA-4, 1-5/8 by 7/8 inches (41 by 22 mm) by length indicated with anchor straps or studs not less than 3 inches (75 mm) long at not more than 8 inches (200 mm) o.c. Provide with temporary filler and tee-head bolts, complete with washers and nuts, all zinc-plated to comply with ASTM B 633, Class Fe/Zn 5, as needed for fastening to inserts.
- D. Steel Bolts and Nuts: Regular hexagon-head bolts, ASTM A 307, Grade A; with hex nuts, ASTM A 563; and, where indicated, flat washers.
- E. Anchor Bolts: ASTM F 1554, Grade 36.
- F. Eyebolts: ASTM A 489.
- G. Machine Screws: ASME B18.6.3.
- H. Lag Bolts: ASME B18.2.1.
- I. Wood Screws: Flat head, ASME B18.6.1.
- J. Plain Washers: Round, ASME B18.22.1.
- K. Lock Washers: Helical, spring type, ASME B18.21.1.
- L. Expansion Anchors: Anchor bolt and sleeve assembly with capability to sustain, without failure, a load equal to six times the load imposed when installed in unit masonry and four times the load imposed when installed in concrete, as determined by testing according to ASTM E 488, conducted by a qualified independent testing agency.
 - 1. Material for Anchors in Interior Locations: Carbon-steel components zinc-plated to comply with ASTM B 633, Class Fe/Zn 5.
 - 2. Material for Anchors in Exterior Locations: Alloy Group 1 stainless-steel bolts complying with ASTM F 593 and nuts complying with ASTM F 594.

2.3 MISCELLANEOUS MATERIALS

- A. Universal Shop Primer: Fast-curing, lead- and chromate-free, universal modified-alkyd primer complying with MPI#79.
 - 1. Use primer with a VOC content of 420 g/L (3.5 lb/gal.) or less when calculated according to 40 CFR 59, Subpart D (EPA Method 24).
 - 2. Use primer containing pigments that make it easily distinguishable from zinc-rich primer.

- B. Zinc-Rich Primer: Complying with SSPC-Paint 20 or SSPC-Paint 29 and compatible with topcoat.
 - 1. Use primer with a VOC content of 420 g/L (3.5 lb/gal.) or less when calculated according to 40 CFR 59, Subpart D (EPA Method 24).
- C. Galvanizing Repair Paint: High-zinc-dust-content paint complying with SSPC-Paint 20 and compatible with paints specified to be used over it.
- D. Bituminous Paint: Cold-applied asphalt emulsion complying with ASTM D 1187.
- E. Non-shrink, Metallic Grout: Factory-packaged, ferrous-aggregate grout complying with ASTM C 1107, specifically recommended by manufacturer for heavy-duty loading applications.
- F. Non-shrink, Nonmetallic Grout: Factory-packaged, non-staining, non-corrosive, nongaseous grout complying with ASTM C 1107. Provide grout specifically recommended by manufacturer for interior and exterior applications.
- G. Concrete Materials and Properties: Comply with requirements in Division 3 Section "Cast-in-Place Concrete" for normal-weight, air-entrained, ready-mix concrete with a minimum 28-day compressive strength of 3000 psi, unless otherwise indicated.

2.4 FABRICATION, GENERAL

- A. Shop Assembly: Preassemble items in the shop to greatest extent possible. Disassemble units only as necessary for shipping and handling limitations. Use connections that maintain structural value of joined pieces. Clearly mark units for reassembly and coordinated installation.
- B. Cut, drill, and punch metals cleanly and accurately. Remove burrs and ease edges to a radius of approximately 1/32 inch, unless otherwise indicated. Remove sharp or rough areas on exposed surfaces.
- C. Form bent-metal corners to smallest radius possible without causing grain separation or otherwise impairing work.
- D. Form exposed work true to line and level with accurate angles and surfaces and straight edges.
- E. Weld corners and seams continuously to comply with the following:
 - 1. Use materials and methods that minimize distortion and develop strength and corrosion resistance of base metals.
 - 2. Obtain fusion without undercut or overlap.
 - 3. Remove welding flux immediately.
 - 4. At exposed connections, finish exposed welds and surfaces smooth and blended so no roughness shows after finishing and contour of welded surface matches that of adjacent surface.
- F. Form exposed connections with hairline joints, flush and smooth, using concealed fasteners where possible. Where exposed fasteners are required, use Phillips flat-head (countersunk) screws or bolts, unless otherwise indicated. Locate joints where least conspicuous.
- G. Fabricate seams and other connections that will be exposed to weather in a manner to exclude water. Provide weep holes where water may accumulate.

- H. Cut, reinforce, drill, and tap metal fabrications as indicated to receive finish hardware, screws, and similar items.
 - I. Provide for anchorage of type indicated; coordinate with supporting structure. Space anchoring devices to secure metal fabrications rigidly in place and to support indicated loads.
 - 1. Where units are indicated to be cast into concrete or built into masonry, equip with integrally welded steel strap anchors, 1/8 by 1-1/2 inches, with a minimum 6-inch embedment and 2-inch hook, not less than 8 inches from ends and corners of units and 24 inches o.c., unless otherwise indicated.
- 2.5 METAL BOLLARDS: Fabricate from Schedule 40 steel pipe, 1/4-inch wall-thickness rectangular steel tubing.
- 1. Cap bollards with concrete.
 - 2. Fabricate bollards with 3/8-inch thick steel baseplates for bolting to concrete slab. Drill baseplates at all four corners for 3/4-inch anchor bolts.
 - 3. Fabricate sleeves for bollard anchorage from steel pipe with 1/4-inch thick steel plate welded to bottom of sleeve. Make sleeves not less than 8 inches deep and 3/4-inch larger than OD of bollard.
 - 4. Prime bollards with zinc-rich primer.
- 2.6 LOOSE STEEL LINTELS
- A. Fabricate loose steel lintels from steel angles and shapes of size indicated for openings and recesses in masonry walls and partitions at locations indicated.
 - B. Galvanize loose steel lintels located in exterior walls.
 - C. Size loose lintels to provide bearing length at each side of openings equal to 1/12 of clear span, but not less than 8 inches, unless otherwise specified.
- 2.7 SHELF ANGLES
- A. Fabricate shelf angles from steel angles of sizes indicated and for attachment to concrete framing. Provide horizontally slotted holes to receive 3/4-inch bolts, spaced not more than 6 inches from ends and 24 inches o.c., unless otherwise indicated.
 - B. For cavity walls, provide vertical channel brackets to support angles from backup masonry and concrete.
 - C. Prime shelf angles located in exterior walls with zinc-rich primer.
 - D. Furnish wedge-type concrete inserts, complete with fasteners, to attach shelf angles to cast-in-place concrete.
- 2.8 GUARD RAILS
- A. Fabricate from steel pipe or tube stock of sizes and types indicated.

- B. Make bends uniform and free from buckles and other defects.
- C. Cut intersections square to within 2 degrees and to length within 1/8 inch. Remove burrs from cut ends.
- D. Miter and cope intersections within 2 degrees, fit to within 1/8 inch.
- E. Continuously weld connections.
- F. Where length exceeds that suitable for shipping and handling, fabricate in sections with concealed internal sleeves forming slip joints. Extend sleeves minimum 2 inches on both sides of joint; field weld and grind smooth.

2.9 MISCELLANEOUS FRAMING AND SUPPORTS

- A. General: Provide steel framing and supports not specified in other Sections as needed to complete the Work.
- B. Fabricate units from steel shapes, plates, and bars of welded construction, unless otherwise indicated. Fabricate to sizes, shapes, and profiles indicated and as necessary to receive adjacent construction retained by framing and supports. Cut, drill, and tap units to receive hardware, hangers, and similar items.
 - 1. Furnish inserts if units are installed after concrete is placed.
- C. Prime miscellaneous framing and supports with zinc-rich primer where indicated.

2.10 LOOSE BEARING AND LEVELING PLATES

- A. Provide loose bearing and leveling plates for steel items bearing on masonry or concrete construction. Drill plates to receive anchor bolts and for grouting.
- B. Prime plates with zinc-rich primer.

2.11 STEEL WELD PLATES AND ANGLES

- A. Provide steel weld plates and angles not specified in other Sections, for items supported from concrete construction as needed to complete the Work. Provide each unit with not less than two integrally welded steel strap anchors for embedding in concrete.

2.12 MISCELLANEOUS STEEL TRIM

- A. Unless otherwise indicated, fabricate units from steel shapes, plates, and bars of profiles shown with continuously welded joints and smooth exposed edges. Miter corners and use concealed field splices where possible.
- B. Provide cutouts, fittings, and anchorages as needed to coordinate assembly and installation with other work.

1. Provide with integrally welded steel strap anchors for embedding in concrete or masonry construction.
- C. Prime exterior miscellaneous steel trim with zinc-rich primer.

2.13 FINISHES, GENERAL

- A. Comply with NAAMM's "Metal Finishes Manual for Architectural and Metal Products" for recommendations for applying and designating finishes.
- B. Finish metal fabrications after assembly.
- C. Galvanizing: Hot-dip galvanize items as indicated to comply with ASTM A 153/A 153M for steel and iron hardware and with ASTM A 123/A 123M for other steel and iron products.

PART 3 - EXECUTION

3.1 INSTALLATION, GENERAL

- A. Cutting, Fitting, and Placement: Perform cutting, drilling, and fitting required for installing metal fabrications. Set metal fabrications accurately in location, alignment, and elevation; with edges and surfaces level, plumb, true, and free of rack; and measured from established lines and levels.
- B. Fit exposed connections accurately together to form hairline joints. Weld connections that are not to be left as exposed joints but cannot be shop welded because of shipping size limitations. Do not weld, cut, or abrade surfaces of exterior units that have been hot-dip galvanized after fabrication and are for bolted or screwed field connections.
- C. Field Welding: Comply with the following requirements:
 1. Use materials and methods that minimize distortion and develop strength and corrosion resistance of base metals.
 2. Obtain fusion without undercut or overlap.
 3. Remove welding flux immediately.
 4. At exposed connections, finish exposed welds and surfaces smooth and blended so no roughness shows after finishing and contour of welded surface matches that of adjacent surface.
- D. Fastening to In-Place Construction: Provide anchorage devices and fasteners where metal fabrications are required to be fastened to in-place construction. Provide threaded fasteners for use with concrete and masonry inserts, toggle bolts, through bolts, lag bolts, wood screws, and other connectors.
- E. Provide temporary bracing or anchors in formwork for items that are to be built into concrete, masonry, or similar construction.

3.2 INSTALLING MISCELLANEOUS FRAMING AND SUPPORTS

- A. General: Install framing and supports to comply with requirements of items being supported, including manufacturers' written instructions and requirements indicated on Shop Drawings.

- B. Support steel girders on solid grouted masonry, concrete or steel pipe columns. Secure girders with anchor bolts embedded in grouted masonry or concrete or with bolts through top plates of pipe columns.
 - 1. Where grout space under bearing plates is indicated for girders supported on concrete or masonry, install as specified in "Installing Bearing and Leveling Plates" Article.
- C. Install pipe columns on concrete footings with grouted base plates. Position and grout column base plates as specified in "Installing Bearing and Leveling Plates" Article.
 - 1. Grout base plates of columns supporting steel girders after girders are installed and leveled.

3.3 INSTALLING METAL BOLLARDS

- A. Anchor bollards in concrete with pipe sleeves preset and anchored into concrete. Fill annular space around bollard solidly with non-shrink, nonmetallic grout; mixed and placed to comply with grout manufacturer's written instructions.
- B. Anchor bollards in place with concrete footings. Place concrete and vibrate or tamp for consolidation. Support and brace bollards in position until concrete has cured.
- C. Fill bollards solidly with concrete, mounding top surface to shed water.

3.4 INSTALLING BEARING AND LEVELING PLATES

- A. Clean concrete and masonry bearing surfaces of bond-reducing materials, and roughen to improve bond to surfaces. Clean bottom surface of plates.
- B. Set bearing and leveling plates on wedges, shims, or leveling nuts. After bearing members have been positioned and plumbed, tighten anchor bolts. Do not remove wedges or shims but, if protruding, cut off flush with edge of bearing plate before packing with grout.
 - 1. Use non-shrink grout, either metallic or nonmetallic, in concealed locations where not exposed to moisture; use non-shrink, nonmetallic grout in exposed locations, unless otherwise indicated.
 - 2. Pack grout solidly between bearing surfaces and plates to ensure that no voids remain.

3.5 INSTALLING GUARD RAILS

- A. Install in accordance with approved Shop Drawings.
- B. Install components plumb, level, and rigid.
- C. Welding: AWS D1.1, D1.2, D1.6. Grind and fill exposed welds; finish smooth and flush.
- D. Install sleeved components with anchoring cement.

3.6 ADJUSTING AND CLEANING

- A. Touch-Up Painting of Steel Items: Immediately after erection, clean field welds, bolted connections, and abraded areas of shop paint, and paint exposed areas with the same material as used for shop painting to comply with SSPC-PA 1 for touching up shop-painted surfaces.
 - 1. Apply by brush or spray to provide a minimum 2.0-mil dry film thickness.
- B. Galvanized Surfaces: Clean field welds, bolted connections, and abraded areas and repair galvanizing to comply with ASTM A780.

END OF SECTION 05 50 00

Page Intentionally Left Blank

SECTION 07 11 13

BITUMINOUS DAMPPROOFING

1.1 SUMMARY

- A. This Section includes the following:
 - 1. Cold-applied, emulsified asphalt dampproofing.

1.2 SUBMITTALS

- A. Product Data: For each type of product indicated.

1.3 PROJECT CONDITIONS

- A. Ventilation: Provide adequate ventilation during application of dampproofing in enclosed spaces. Maintain ventilation until dampproofing has cured.

PART 2 - PRODUCTS

2.1 COLD-APPLIED, EMULSIFIED-ASPHALT DAMPPROOFING

- A. Manufacturers: Subject to compliance with requirements, provide products by one of the following:
 - 1. ChemMasters Corp.
 - 2. APOC, Inc.; a division of Gardner-Gibson.
 - 3. BASF Construction Chemicals – Building Systems; Sonneborn Brand Products.
 - 4. Bruer Company.
 - 5. Euclid Chemical Company; an RPM company.
 - 6. Henry Company.
 - 7. Karnak Corporation.
 - 8. Koppers Inc.
 - 9. Malarkey Roofing Products.
 - 10. Meadows, W. R., Inc.
 - 11. Approved Equal.
- B. Trowel Coats: ASTM D 1227, Type II, Class 1.
- C. Fibered Brush and Spray Coats: ASTM D 1227, Type II, Class 1.
- D. Brush and Spray Coats: ASTM D 1227, Type III, Class 1.
- E. VOC Content: Zero.

2.2 PROTECTION COURSE

- A. Protection Course, Asphalt-Board Type: ASTM D 6506, premolded, 1/8-inch-thick, multi-ply, semirigid board consisting of a mineral-stabilized asphalt core sandwiched between layers of asphalt-saturated felt, and faced on 1 side with polyethylene film.

2.3 MISCELLANEOUS MATERIALS

- A. General: Furnish auxiliary materials recommended in writing by dampproofing manufacturer for intended use and compatible with bituminous dampproofing.
- B. Emulsified-Asphalt Primer: ASTM D 1227, Type III, Class 1, except diluted with water as recommended by manufacturer.
- C. Asphalt-Coated Glass Fabric: ASTM D 1668, Type I.

PART 3 - EXECUTION

3.1 PREPARATION

- A. Clean substrates of projections and substances detrimental to work; fill voids, seal joints, and apply bond breakers if any, as recommended by prime material manufacturer.

3.2 APPLICATION, GENERAL

- A. Comply with manufacturer's written instructions for substrate preparation, dampproofing application, cure time between coats, and drying time before backfilling unless more stringent requirements are indicated or required by Project conditions to ensure satisfactory performance of dampproofing.
 - 1. Apply dampproofing to provide continuous plane of protection.
 - 2. Apply additional coats if recommended in writing by manufacturer to achieve a smooth surface and uninterrupted coverage.
- B. Apply dampproofing to footings and foundation walls where opposite side of wall faces building interior.
 - 1. Apply from finished-grade line to top of footing, extend over top of footing, and down a minimum of 6 inches over outside face of footing.
 - 2. Extend 12 inches onto intersecting walls and footings, but do not extend onto surfaces exposed to view when Project is completed.
 - 3. Install flashings and corner protection stripping at internal and external corners, changes in plane, construction joints, cracks, and where shown as "reinforced," by embedding an 8-inch-wide strip of asphalt-coated glass fabric in a heavy coat of dampproofing. Dampproofing coat for embedding fabric is in addition to other coats required.

- C. Apply dampproofing to provide continuous plane of protection on exterior face of inner wythe of exterior masonry cavity walls.
- D. Apply dampproofing to provide continuous plane of protection on interior face of above-grade, exterior concrete and masonry walls unless walls are indicated to receive direct application of paint.

3.3 COLD-APPLIED, EMULSIFIED-ASPHALT DAMPPROOFING

- A. On Concrete Foundations where indicated: Apply 2 brush or spray coats at not less than 1.5 gal./100 sq. ft. for first coat and 1 gal./100 sq. ft. for second coat, 1 fibered brush or spray coat at not less than 3 gal./100 sq. ft., or 1 trowel coat at not less than 4 gal./100 sq. ft.
- B. Face of Concrete Retaining Walls: Apply one brush or spray coat at not less than 1.25 gal./100 sq. ft.
- C. Interior Face of Exterior Concrete Walls: Where above grade and indicated to be furred and finished, apply one brush or spray coat at not less than 1 gal./100 sq. ft.

3.4 INSTALLATION OF PROTECTION COURSE

- A. Where indicated, install protection course over completed-and-cured dampproofing. Comply with dampproofing material manufacturer's written recommendations for attaching protection course.
 - 1. Support protection course with spot application of adhesive of type recommended by protection board manufacturer over cured coating.
 - 2. Install protection course on same day of installation of dampproofing (while coating is tacky) to ensure adhesion.

END OF SECTION 07 11 13

Page Intentionally Left Blank

SECTION 07 14 21

LATEX MASTIC DECK COVERING

PART 1 – GENERAL

1.1 SUMMARY

A. This Section specified latex mastic covering for waterproofing deck surfacing.

1.2 SUBMITTALS

A. Product Data: Submit manufacturer’s product data sheets on each product and system to be used including:

1. Preparation instructions and recommendations.
2. Storage and handling requirements.
3. Installation methods.
4. Maintenance requirements.

B. Selection Samples: For each system specified, provide two sets of samples and color charts, representing manufacturer’s full range of colors and patterns.

1.3 QUALITY ASSURANCE

A. Manufacturer’s Qualifications: Latex mastic deck covering manufacturer to have a minimum of five (5) years’ experience in manufacturing latex mastic deck covering products specified herein. Obtain products from single manufacturer or from sources recommended by manufacturer for use with latex mastic deck covering and incorporated in manufacturer’s warranty. Submit manufacturer’s qualifications.

B. Installers Qualifications: Work is to be performed by installer having three (3) years’ experience for work relating to this section and approved in writing by latex mastic deck covering manufacturer. Submit installer qualifications

1.4 APPLICABLE PUBLICATIONS

A. Publications listed below form a part of this specification to the extent referenced. Publications are referenced in the text by the basic designation only.

B. ASTM International (ASTM):

- D412-06a (R2013)..... Vulcanized Rubber and Thermoplastic Elastomers-Tension
- D570-98(R2010) e1..... Water Absorption of Plastics
- D903-98(R2010)Peel or Stripping Strength of Adhesive Bonds
- D2240-05(R2010)Rubber Property-Durometer Hardness

1.5 SUBMITTALS

- A. Samples: 6 inch square, each color.
- B. Manufacturer's Literature and Data:
 - 1. Latex mastic deck covering.
 - 2. Installation instructions.
 - 3. Primer.
- C. Certificates:
 - 1. Compliance of material with specification requirements.
 - 2. Manufacturer's qualifications as specified.
 - 3. Installer's qualifications as specified.
- D. Manufacturer Warranty.

1.6 DELIVERY

- A. Delivery: Materials shall be delivered to the job site in original sealed, undamaged containers. Each container shall be clearly marked with manufacturer's name and brand.
- B. Storage: Store all materials in a clean, dry place within the temperature range recommended by manufacturer's instructions.

1.7 WARRANTY

- A. Manufacturer Warranty: Manufacturer shall warranty its latex mastic deck covering for a minimum of five (5) years starting from the date of Substantial Completion.

PART 2 - PRODUCTS

2.1 LATEX MASTIC DECK COVERING

- A. Product to be a trowel applied elastomeric material meeting all performance requirements specified and designed primarily for waterproofing deck surfacing.

2.2 PRIMER

- A. As recommended by the Latex Mastic Covering manufacturer.

2.3 PERFORMANCE REQUIREMENTS

- A. Tensile Strength: ASTM D412: Not less than 7240 KPa (1050 psi).

- B. Water Transmission: ASTM D570: None when subjected to a water pressure of 345 KPa (50 psi) for a period of one (1) hour.
- C. Hardness: ASTM D2240: 60-70 Shore "A".
- D. Adhesive Strength: ASTM D903: Not less than 1035 kPa (150 psi).
- E. Weight: 1.8 kg per sq. m (0.45 lbs. per sq. ft.).
- F. Elongation: ASTM D412: 500 percent (of original benchmark distance).
- G. The topcoat color to be selected by Architect from manufacturer's full range.

PART 3 – EXECUTION

3.1 ENVIRONMENTAL REQUIREMENTS

- A. Apply deck covering coating as per the manufacturer's written instructions.

3.2 INSTALLATION

- A. Prepare surface by removing dirt or other foreign matter including any concrete curing agents.
- B. Apply primer by roller.
- C. Apply basecoat and pigmented topcoat as per manufacturer's instructions. Turn up the material against walls to form an integral waterproof membrane.
- D. Provide finish of two coats for a total minimum thickness not less than 1/6 inch.

3.5 PROTECTION AND CLEAN-UP

- A. Installation areas must be kept free from traffic and other trades during the application procedure and drying time.
- B. Protect finished surfaces from damage during construction.
- C. Touch-up, repair or replace waterproofing after Substantial Completion.
- D. Clean area and remove all debris upon completion of work. Dispose of empty containers properly according to current local, state and federal regulations.

END OF SECTION 07 14 21

Page Intentionally Left Blank

SECTION 08 11 13

HOLLOW METAL DOORS AND FRAMES

PART 1 - GENERAL

1.1 SUMMARY

- A. This Section includes the following:
 - 1. Standard hollow metal doors and frames.

1.2 DEFINITIONS

- A. Minimum Thickness: Minimum thickness of base metal without coatings.

1.3 SUBMITTALS

- A. Product Data: Include construction details, material descriptions, core descriptions, label compliance, fire-resistance rating, and finishes for each type of hollow metal door and frame specified.

1.4 QUALITY ASSURANCE

- A. Installer Qualifications: An employer of workers trained and approved by manufacturer.
- B. Source Limitations: Obtain standard hollow metal doors and frames through one source from a single manufacturer.
- C. Fire-Rated Door and Borrowed-Light Frame Assemblies: Assemblies complying with NFPA 80 that are listed and labeled by a testing and inspecting agency acceptable to authorities having jurisdiction, for fire-protection ratings indicated.
 - 1. Temperature-Rise Limit: At exit enclosures, provide doors that have a temperature-rise rating of 450 deg F in 30 minutes of fire exposure.
- D. Smoke-Control Door Assemblies: Comply with NFPA 105.

1.5 DELIVERY, STORAGE, AND HANDLING

- A. Deliver doors and frames palletized, wrapped, or crated to provide protection during transit and Project-site storage. Do not use non-vented plastic.
- B. Deliver welded frames with two removable spreader bars across bottom of frames, tack welded to jambs and mullions.

- C. Store doors and frames under cover at Project site. Place units in a vertical position with heads up, spaced by blocking, on minimum 4-inch- high wood blocking. Avoid using non-vented plastic or canvas shelters that could create a humidity chamber.
 - 1. If wrappers on doors become wet, remove cartons immediately. Provide minimum 1/4-inch space between each stacked door to permit air circulation.

1.6 PROJECT CONDITIONS

- A. Field Measurements: Verify openings by field measurements before fabrication.

PART 2 - PRODUCTS

2.1 MANUFACTURERS

- A. Manufacturers: Subject to compliance with requirements, provide products by one of the following:
 - 1. Steelcraft.
 - 2. Curries Company.
 - 3. Firedoor Corporation.
 - 4. Mesker Door.
 - 5. Security Metal Products.
 - 6. Approved equal.

2.2 MATERIALS

- A. Cold-Rolled Steel Sheet: ASTM A 1008/A 1008M, Commercial Steel (CS), Type B; suitable for exposed applications.
- B. Hot-Rolled Steel Sheet: ASTM A 1011/A 1011M, Commercial Steel (CS), Type B.
- C. Metallic-Coated Steel Sheet: ASTM A 653/A 653M, Commercial Steel (CS), Type B; with minimum A40 metallic coating.
- D. Electrolytic Zinc-Coated Steel Sheet: ASTM A 591/A 591M, Commercial Steel (CS), Class B coating; mill phosphatized.
- E. Supports and Anchors: After fabricating, galvanize units to be built into exterior walls according to ASTM A 153/A 153M, Class B.
- F. Frame Anchors: ASTM A 879/A 879M, Commercial Steel (CS), 04Z coating designation; mill phosphatized.
 - 1. For anchors built into exterior walls, steel sheet complying with ASTM A 1008/A 1008M or ASTM A 1011/A 1011M, hot-dip galvanized according to ASTM A 153/A 153M.

- G. Inserts, Bolts, and Fasteners: Provide items to be built into exterior walls, hot-dip galvanized according to ASTM A 153/A 153M.
- H. Powder-Actuated Fasteners in Concrete: Fastener system of type suitable for application indicated, fabricated from corrosion-resistant materials, with clips or other accessory devices for attaching standard hollow metal door frames of type indicated.
- I. Mineral-Fiber Insulation: ASTM C 665, Type I (blankets without membrane facing); consisting of fibers manufactured from slag or rock wool with 6- to 12-lb/cu. ft. density; with maximum flame-spread and smoke-developed indexes of 25 and 50 respectively; passing ASTM E 136 for combustion characteristics.
- J. Bituminous Coating: Cold-applied asphalt mastic, SSPC-Paint 12, compounded for 15-mil dry film thickness per coat. Provide inert-type non-corrosive compound free of asbestos fibers, sulfur components, and other impurities.

2.3 STANDARD HOLLOW METAL DOORS

- A. General: Provide doors of design indicated, not less than thickness indicated; fabricated with smooth surfaces, without visible joints or seams on exposed faces, unless otherwise indicated. Comply with ANSI/SDI A250.
- B. Design:
 - 1. Core Construction: Manufacturer's standard kraft-paper honeycomb, polystyrene, polyurethane, mineral-board, or vertical steel-stiffener core that produces door complying with ANSI A250.8.
 - a. Fire Door Core: As required to provide fire-protection ratings indicated.
 - 2. Vertical Edges for Single-Acting Doors: Beveled edge unless square edge is indicated.
 - a. Beveled edge: 1/8 inch in 2 inches.
 - 3. Top and Bottom Edges: Closed with flush or inverted 0.042-inch-thick, end closures or channels of same material as face sheets.
 - 4. Tolerances: Comply with SDI 117, "Manufacturing Tolerances for Standard Steel Doors and Frames."
- C. Exterior Doors: Face sheets fabricated from metallic-coated steel sheet. Provide doors complying with requirements indicated below by referencing ANSI/SDI A250.8 for level and model and ANSI/SDI A250.4 for physical-endurance level:
 - 1. Level 2 and Physical Performance Level B (Heavy Duty), Model 1 (Full Flush).
- D. Hardware Reinforcement: Fabricate reinforcement plates from same material as door face sheets to comply with the following minimum sizes:
 - 1. Hinges: Minimum 0.123 inch thick by 1-1/2 inches wide by 6 inches longer than hinge, secured by not less than 6 spot welds.

2. Pivots: Minimum 0.167 inch thick by 1-1/2 inches wide by 6 inches longer than hinge, secured by not less than 6 spot welds.
 3. Lock Face Closers, and Concealed Holders: Minimum 0.067 inch thick.
 4. All Other Surface-Mounted Hardware: Minimum 0.067 inch thick.
- E. Fabricate concealed stiffeners and hardware reinforcement from either cold- or hot-rolled steel sheet.

2.4 STANDARD HOLLOW METAL FRAMES

- A. General: Comply with ANSI/SDI A250.8 and with details indicated for type and profile.
- B. Exterior Frames: Fabricated from metallic-coated steel sheet.
1. Fabricate frames with mitered or coped and welded corners and seamless face joints.
 2. Sheet Steel Thickness for Exterior Doors: 0.042-inch-thick, unless otherwise indicated.
- C. Hardware Reinforcement: Fabricate reinforcement plates from same material as frames to comply with the following minimum sizes:
1. Hinges: Minimum 0.123 inch thick by 1-1/2 inches wide by 6 inches longer than hinge, secured by not less than 6 spot welds.
 2. Pivots: Minimum 0.167 inch thick by 1-1/2 inches wide by 6 inches longer than hinge, secured by not less than 6 spot welds.
 3. Lock Face Closers, and Concealed Holders: Minimum 0.067 inch thick.
 4. All Other Surface-Mounted Hardware: Minimum 0.067 inch thick.
- D. Supports and Anchors: Fabricated from electrolytic zinc-coated or metallic-coated steel sheet.
- E. Jamb Anchors:
1. Masonry Type: Adjustable strap-and-stirrup or T-shaped anchors to suit frame size, not less than 0.042 inch thick, with corrugated or perforated straps not less than 2 inches wide by 10 inches long; or wire anchors not less than 0.177 inch thick.
 2. Stud-Wall Type: Designed to engage stud, welded to back of frames; not less than 0.042 inch thick.
 3. Compression Type for Drywall Slip-on-Frames: Adjustable compression anchors.
 4. Post-Installed Expansion Type for In-Place Concrete or Masonry: Minimum 3/8 inch diameter bolts with expansion shields or inserts. Provide pipe spacer from frame to wall, with throat reinforcement plate, welded to frame at each anchor location.
- F. Floor Anchors: Formed from same material as frames, not less than 0.042 inch thick.
- G. Fabricate concealed stiffeners and hardware reinforcement from either cold- or hot-rolled steel sheet.

2.5 FABRICATION

- A. General: Fabricate standard hollow metal doors and frames to be rigid and free of defects, warp, or buckle. Accurately form metal to required sizes and profiles, with minimum radius for thickness

of metal. Where practical, fit and assemble units in manufacturer's plant. To ensure proper assembly at Project site, clearly identify work that cannot be permanently factory assembled before shipment.

B. Standard Hollow Metal Doors:

1. Exterior Doors: Provide weep-hole openings in bottom of exterior doors to permit moisture to escape. Seal joints in top edges of doors against water penetration.

C. Standard Hollow Metal Frames: Where frames are fabricated in sections, provide alignment plates or angles at each joint, fabricated of same thickness metal as frames.

1. Welded Frames: Weld flush face joints continuously; grind, fill, dress, and make smooth, flush, and invisible.
2. Sidelight Frames: Provide closed tubular members with no visible face seams or joints, fabricated from same material as door frame. Fasten members at crossings and to jambs by butt welding.
3. Provide countersunk, flat- or oval-head exposed screws and bolts for exposed fasteners unless otherwise indicated.
4. Grout Guards: Provide where mortar might obstruct hardware operation.
5. Floor Anchors: Weld anchors to bottom of jambs and mullions with at least four spot welds per anchor.
6. Jamb Anchors: Provide number and spacing of anchors as follows:
 - a. Masonry Type: Locate anchors not more than 18 inches from top and bottom of frame. Space anchors not more than 32 inches o.c. and as follows:
 - 1) Three anchors per jamb from 60 to 90 inches high.
 - 2) Four anchors per jamb from 90 to 120 inches high.
 - 3) Four anchors per jamb plus 1 additional anchor per jamb for each 24 inches or fraction thereof above 120 inches high.
 - b. Stud-Wall Type: Locate anchors not more than 18 inches from top and bottom of frame. Space anchors not more than 32 inches o.c. and as follows:
 - 1) Four anchors per jamb from 60 to 90 inches high.
 - 2) Five anchors per jamb from 90 to 96 inches high.
 - 3) Five anchors per jamb plus 1 additional anchor per jamb for each 24 inches or fraction thereof above 96 inches high.
 - 4) Two anchors per head for frames more than 42 inches wide and mounted in metal-stud partitions.

D. Hardware Preparation: Factory prepare hollow metal work to receive templated mortised hardware include cutouts, reinforcement, mortising, drilling and tapping.

1. Reinforce doors and frames to receive non-templated, mortised and surface-mounted door hardware.
2. Comply with applicable requirements in ANSI/SDI A250.6 and ANSI/DHI A115 Series specifications for door and frame preparation for hardware. Locate hardware according to ANSI A250.8.

2.6 STEEL FINISHES

- A. General: Comply with NAAMM's "Metal Finishes Manual for Architectural and Metal Products" for recommendations for applying and designating finishes.
 - 1. Finish hollow metal frames after assembly.
- B. Metallic-Coated Steel Surface Preparation: Clean surfaces with non-petroleum solvent so surfaces are free of oil and other contaminants. After cleaning, apply a conversion coating suited to the organic coating to be applied over it. Clean welds, mechanical connections, and abraded areas, and apply galvanizing repair paint specified below to comply with ASTM A 780.
 - 1. Galvanizing Repair Paint: High-zinc-dust-content paint for regalvanizing welds in steel, complying with SSPC-Paint 20.
- C. Steel Surface Preparation: Clean surfaces to comply with SSPC-SP 1, "Solvent Cleaning"; remove dirt, oil, grease, or other contaminants that could impair paint bond. Remove mill scale and rust, if present, from uncoated steel; comply with SSPC-SP 3, "Power Tool Cleaning," or SSPC-SP 6/NACE No. 3, "Commercial Blast Cleaning."
- D. Factory Priming for Field-Painted Finish: Apply shop primer specified below immediately after surface preparation and pretreatment. Apply a smooth coat of even consistency to provide a uniform dry film thickness of not less than 0.7 mils.
 - 1. Shop Primer: Manufacturer's standard, fast-curing, lead- and chromate-free primer complying with ANSI A250.10 acceptance criteria; recommended by primer manufacturer for substrate; compatible with substrate and field-applied finish paint system indicated; and providing a sound foundation for field-applied topcoats despite prolonged exposure.

PART 3 - EXECUTION

3.1 EXAMINATION

- A. Examine substrates, areas, and conditions, with Installer present, for compliance with requirements for installation tolerances and other conditions affecting performance of standard hollow metal doors and frames.
 - 1. Examine roughing-in for embedded and built-in anchors to verify actual locations of hollow metal frame connections before frame installation.
 - 2. For the record, prepare written report, endorsed by Installer, listing conditions detrimental to performance of work.
 - 3. Proceed with installation only after unsatisfactory conditions have been corrected.

3.2 PREPARATION

- A. Remove welded-in shipping spreaders installed at factory.
- B. Prior to installation and with installation spreaders in place, adjust and securely brace hollow metal door frames for squareness, alignment, twist, and plumb to the following tolerances:

1. Squareness: Plus or minus 1/16 inch, measured at door rabbet on a line 90 degrees from jamb perpendicular to frame head.
 2. Alignment: Plus or minus 1/16 inch, measured at jambs on a horizontal line parallel to plane of wall.
 3. Twist: Plus or minus 1/16 inch, measured at opposite face corners of jambs on parallel lines, and perpendicular to plane of wall.
 4. Plumbness: Plus or minus 1/16 inch, measured at jambs on a perpendicular line from head to floor.
- C. Drill and tap doors and frames to receive non-templated mortised and surface-mounted door hardware.

3.3 INSTALLATION

- A. General: Provide doors and frames of sizes, thicknesses, and designs indicated. Install hollow metal doors and frames plumb, rigid, properly aligned, and securely fastened in place; comply with Drawings and manufacturer's written instructions.
- B. Hollow Metal Frames: Install hollow metal frames for doors of size and profiles indicated. Comply with ANSI/SDI A250.11.
1. Set frames accurately in position, plumbed, aligned, and braced securely until permanent anchors are set. After wall construction is complete, remove temporary braces, leaving surfaces smooth and undamaged.
 - a. At fire-protection-rated openings, install frames according to NFPA 80.
 - b. Where frames are fabricated in sections due to shipping or handling limitations, field splice at approved locations by welding face joint continuously; grind, fill, dress, and make splice smooth, flush, and invisible on exposed faces.
 - c. Remove temporary braces necessary for installation only after frames have been properly set and secured.
 - d. Check plumb, squareness, and twist of frames as walls are constructed. Shim as necessary to comply with installation tolerances.
 - e. Apply bituminous coating to backs of frames that are filled with mortar, grout and plaster containing anti-freezing agents.
 2. Floor Anchors: Provide floor anchors for each jamb and mullion that extends to floor, and secure with post-installed expansion anchors.
 - a. Floor anchors may be set with powder-actuated fasteners instead of post-installed expansion anchors if so indicated and approved on Shop Drawings.
 3. Metal-Stud Partitions: Solidly pack mineral-fiber insulation behind frames.
 4. Masonry Walls: Coordinate installation of frames to allow for solidly filling space between frames and masonry with mortar as specified in Division 5 Section "Unit Masonry Assemblies."
 5. Concrete Walls: Solidly fill space between frames and concrete with grout. Take precautions, including bracing frames, to ensure that frames are not deformed or damaged by grout forces.

6. In-Place Concrete or Masonry Construction: Secure frames in place with post-installed expansion anchors. Countersink anchors, and fill and make smooth, flush, and invisible on exposed faces.
 7. In-Place Gypsum Board Partitions: Secure frames in place with post-installed expansion anchors through floor anchors at each jamb. Countersink anchors, and fill and make smooth, flush, and invisible on exposed faces.
 8. Ceiling Struts: Extend struts vertically from top of frame at each jamb to overhead structural supports or substrates above frame unless frame is anchored to masonry or to other structural support at each jamb. Bend top of struts to provide flush contact for securing to supporting construction. Provide adjustable wedged or bolted anchorage to frame jamb members.
 9. Installation Tolerances: Adjust hollow metal door frames for squareness, alignment, twist, and plumb to the following tolerances:
 - a. Squareness: Plus or minus 1/16 inch, measured at door rabbet on a line 90 degrees from jamb perpendicular to frame head.
 - b. Alignment: Plus or minus 1/16 inch, measured at jambs on a horizontal line parallel to plane of wall.
 - c. Twist: Plus or minus 1/16 inch, measured at opposite face corners of jambs on parallel lines, and perpendicular to plane of wall.
 - d. Plumbness: Plus or minus 1/16 inch, measured at jambs at floor.
- C. Hollow Metal Doors: Fit hollow metal doors accurately in frames, within clearances specified below. Shim as necessary.
1. Non-Fire-Rated Standard Hollow Metal Doors:
 - a. Jambs and Head: 1/8 inch plus or minus 1/16 inch.
 - b. Between Edges of Pairs of Doors: 1/8 inch plus or minus 1/16 inch.
 - c. Between Bottom of Door and Top of Threshold: Maximum 3/8 inch.
 - d. Between Bottom of Door and Top of Finish Floor (No Threshold): Maximum 3/4 inch.
 2. Fire-Rated Doors: Install doors with clearances according to NFPA 80.
 3. Smoke-Control Doors: Install doors according to NFPA 105.

3.4 ADJUSTING AND CLEANING

- A. Final Adjustments: Check and readjust operating hardware items immediately before final inspection. Leave work in complete and proper operating condition. Remove and replace defective work, including standard hollow metal doors or frames that are warped, bowed, or otherwise unacceptable.
- B. Prime-Coat Touchup: Immediately after erection, sand smooth rusted or damaged areas of prime coat and apply touchup of compatible air-drying, rust-inhibitive primer.
- C. Metallic-Coated Surfaces: Clean abraded areas and repair with galvanizing repair paint according to manufacturer's written instructions.

END OF SECTION 08 11 13

SECTION 08 36 14

HIGH-SPEED ROLLING DOORS

PART 1 – GENERAL

1.01 SECTION INCLUDES

- A. High-speed roll up doors.

1.02 RELATED SECTIONS

- A. Misc. Metal Fabrications

1.03 REFERENCES

- A. NEMA – National Electrical Manufacturers Association.
- B. LED – Light Emitting Diode.

1.04 SYSTEM DESCRIPTION

- A. Motor type: AC drive, and variable speed with soft acceleration and braking. Manual brake release allows door to be opened in the event of a power failure.

1.05 SUBMITTALS

- A. Submit the following:
 - 1. Shop Drawings: Indicate pertinent dimensioning, anchorage methods, hardware locations, and installation details.
 - 2. Product Data: Provide general construction, component connections and details, and electrical equipment, operation instructions, and information.
 - 3. Samples: Submit color samples of door panels for selection by owner.
 - 4. Manufacturer's Installation: Indicate installation sequence and procedures, adjustment and alignment procedures.

1.06 MAINTENANCE DATA

- A. Maintenance Data: Scheduled maintenance program available to include lubrication requirements and frequency, periodic adjustments required, scheduled maintenance suggested, manufacturer's data sheets, and equipment interconnection diagrams.

1.07 REGULATORY REQUIREMENTS

- A. Electrical components NEMA approved and UL listed.

1.08 QUALITY ASSURANCE

- A. Furnish high-speed roll doors and all components and accessories by one manufacturer.
- B. Specific door model used must have a proven track record of successful installations in similar applications of no less than 10 years. Verification to be provided upon request.

1.09 FIELD MEASUREMENTS

- A. Verify field measurements are as indicated on shop drawings.

1.10 COORDINATION

- A. Coordinate the work with installation of electric power and locations/sizes of conduit.

1.11 WARRANTY

- A. Two-year limited warranty on materials and workmanship.
- B. Five-year limited warranty on 3-ply panel material.

PART 2 – PRODUCTS

2.01 PRODUCTS

- A. Basis of Design: Rytec Corporation PredaDoor NXT
- B. Approved equal, complete substitution request form.

2.02 MATERIALS

- A. Door Panel: Minimum 0.10 inch thick, 86 ounce, 3-ply Rilon material.
 - 1. Individual panel sections connected by two integral, extruded panel connecting ribs.
 - 2. Panel material to be multi-layered, woven, dimensionally stable, puncture resistant, polymer impregnated, multi-filament polyester fabric.
 - 3. Door panel material to be laterally stiff and vertically flexible. Materials that are flexible both vertically and laterally will not be accepted.
 - 4. No vision panel.
 - 5. Door panel to have modular design to allow easy panel section replacement.
 - a. Door panels with sections that are sewn, screwed or otherwise mechanically fastened to the other panel sections will not be accepted.
- B. Side Frames: Fully bolt-together, anodized aluminum construction.
 - 1. Dual, full-height brush weatherseal to seal against both sides of the door panel.

- C. Bottom Bar: Rigid, extruded aluminum breakaway bottom bar capable of releasing from side columns when hit from either direction without damaging or bending of bottom bar, safety astragal, or side covers.
 - 1. Bottom bar to have the ability to be reset - without tools, equipment, replacement parts or replacement hardware – after it has been impacted and broken away.
 - a. After door is impacted and bottom bar is separated from side frames it can be reset after user alignment by pressing button on face of control box.
 - 2. Dual “kill” switches to automatically shut off motor when door is impacted. Door movement is to stop immediately upon bottom bar releasing from side columns – no continued movement allowed.
 - 3. Bottom bar to be wireless. Break-away and reversing edge signal is carried to the door controller via radio frequency. Doors using coil cords will not be accepted.
 - a. Wireless system to provide control-reliable, two-way communication between the bottom bar and the door controls for safety.
 - b. During door operation, time lapse between bottom bar and door controls communication shall not exceed 5 milliseconds.
 - c. Estimated battery life of wireless system to be no less than 3 years. Control box to indicate the need for battery replacement before low power is detected.
 - d. Wireless system to employ frequency-hopping technology to eliminate signal interference, “cross talk” and RFID interference.
 - e. Wireless system firmware to be upgradeable for future updates/enhancements without requiring additional wiring or components.
 - f. Bottom bar pre-assembled on doors at factory.
- D. Drive System: Variable-speed AC Drive provides soft acceleration and deceleration.
 - 1. 208v, 1-phase power. Motor on right hand side, as facing the interior.
 - 2. Motors using a clutch or brake to start or stop door movement will not be accepted.
 - 3. Brake release to allow manual operation of door in the event of a power failure.
- E. Travel Speed: Door to open at up to 50” per second and close at 21” per second.
 - 1. Both opening and closing travel speed to be independently adjustable using touchpad on face of control box.
- F. Electrical Controls: Housed in a UL/cUL listed, NEMA 4X rated, impact-resistant polycarbonate plastic enclosure with factory set parameters.
 - 1. Two-line, vacuum fluorescent display provides scrolling self-diagnostic and status messaging as well as quick, straightforward installation and control adjustments.
 - 2. 12 programmable inputs and 4 programmable outputs to accommodate control applications without the need for additional electrical components.
 - 3. Tamperproof cycle counter viewable without opening enclosure.
 - 4. Controls to maintain a complete history of door for a minimum of two years. For ease of troubleshooting, history can be logged and encrypted onto a USB flash drive. All errors to have a time and date stamp for reference.
 - 5. Programming and adjustments made using touchpad on face of control box.
 - a. Control panels that require opening the control box, being exposed to high voltage or a portable device for programming will not be accepted.
 - 6. Door control panel to provide power for all ancillary safety and activation items. No separate power source for these items to be required.

7. Power and Control wire and conduit provided and installed by the High Speed Door Trade Contractor.
- G. Travel Limits: Door to use absolute rotary encoder to regulate door travel limits.
 1. Limits to be adjustable without the use of tools from floor level at the control panel.
 2. Control software to incorporate a self-adjusting limit feature, the software monitors the door position and adjusts the limits as required to maintain a proper seal.
 3. Doors using mechanical limit switches or doors that require access to the operator in order to adjust limits will not be accepted.
- H. Safety Devices:
 1. Dual thru-beam photo eyes.
 2. Full-width, dual-chambered pneumatic reversing edge along bottom of door instantly stops and reverses door to its full open limit when coming into contact with an obstruction above floor line during downward travel.
 3. Pathwatch Safety Light System - One (1) 40" high LED light strip mounted to interior of each door side column. Amber lights to flash to preannounce door closing and turn solid red as door closes. Lights must be viewable at the door threshold from both sides of opening.
- I. Activation:
 1. Two (2) remote-mount, keyed open/close/stop pushbutton
- J. Colors/Finishes: All components factory finished.
 1. Door panel color to be selected by owner from a full range of standard color options.

PART 3 – EXECUTION

3.01 EXAMINATION

- A. Verify that opening sizes, tolerances, and conditions are acceptable.

3.02 INSTALLATION

- A. Install door unit assembly in accordance with manufacturer's instructions.
- B. Use anchorage devices to securely fasten assembly to wall construction and building framing without distortion or stress.
- C. Fit and align assembly including hardware; level to plumb to provide smooth operation.

3.03 ADJUSTING

- A. Adjust door and operating assemblies.
- B. Test and adjust doors, if necessary, for proper operation.

3.04 CLEANING

- A. Clean door and components.

END OF SECTION 08 36 14

SECTION 09 97 26

CEMENTITIOUS COATINGS

PART 1 – GENERAL

1.1 SUMMARY

- A. Section includes: Provide a complete cement-based waterproof coating system for concrete and masonry surfaces that meet the requirements for specific use indicated in the contract documents. Include all applicable substrate testing, surface preparation, and detail work.

1.2 RELATED SECTIONS

- A. Section 03 30 00 Cast-In-Place Concrete

1.3 SUBMITTALS

- A. Product Data: Submit manufacturer's product data sheets on each product and system to be used including:
 - 1. Preparation instructions and recommendations.
 - 2. Storage and handling requirements.
 - 3. Installation methods.
 - 4. Maintenance requirements.
- B. Selection Samples: For each system specified, provide two sets of samples and color charts, representing manufacturer's full range of colors and patterns.

1.4 QUALITY ASSURANCE

- A. All materials used in the cement-based waterproof coating system shall be manufactured and provided by a single manufacturer to ensure compatibility and proper bonding.
- B. Use adequate numbers of skilled workers that are thoroughly trained and experienced in the necessary crafts and completely familiar with the specified requirements and methods needed for proper performance of the work of this section.
- C. Contractor shall have a minimum of three years' experience installing cementitious coatings similar to that which is required for this project and must be acceptable to the manufacturer.
 - 1. Applicator shall designate a single individual as project foreman who shall be on site at all times during installation.
 - 2. Contractor must show and have QCA Qualified Contractor/Applicator paperwork from the manufacturer of the coating system, as required to obtain a long-term jobsite specific warranty.
- D. Convene a meeting before the start of application of coating system. Require attendance of parties directly affecting work of this section, including: Architect, contractor, applicator, and

CEMENTITIOUS COATINGS

authorized representative of the coating system manufacturer and interfacing trades. Review the following:

1. Drawings and specifications affecting work of this section.
2. Protection of adjacent surfaces.
3. Surface preparation and substrate conditions.
4. Application.
5. Field quality control.
6. Protection of coating system.
7. Repair of coating system.
8. Coordination with other work.

1.5 DELIVERY, STORAGE & HANDLING

- A. Delivery: Materials shall be delivered to the job site in sealed, undamaged containers. Each container shall be clearly marked with manufacturer's label showing type of material, color, and lot number.
- B. Storage: Store all materials in a clean, dry place with a temperature range in accordance with manufacturer's instructions.
- C. Handling: Handle products carefully to avoid damage to the containers. Read all labels and material safety data sheets prior to use.

1.6 PROJECT SITE CONDITIONS

- A. Maintain environmental conditions (temperature, humidity, and ventilation) within the limits recommended by the manufacturer.
- B. Do not apply to frozen or frost covered walls, or when ambient temperature is below 40° F.
- C. Concrete shall be tested for moisture before applying cementitious coating. Water vapor transmission upwards through on-grade concrete slabs may result in loosening of cementitious coating or improper curing of materials. If moisture emissions exceed 5 pounds per 1,000 square feet contact the manufacturer before application.
- D. Concrete must be at least 2500 psi and feel like 30 or 50 grit sandpaper.
- E. Concrete must be cured for a minimum of 28 days before coating is applied.
- F. Schedule coating work to avoid excessive dust and airborne contaminants. Protect work areas from excessive dust and airborne contaminants during coating application.
- G. Before any work is started, the applicator shall examine all surfaces for any deficiencies. Should any deficiencies exist, the architect, owner or general contractor shall be notified in writing and any corrections necessary shall be made.

1.7 WARRANTY

- A. Upon completion of the work in this section provide a written warranty from the manufacturer against defects of materials for a period of 10 (ten) years.

PART 2 - PRODUCTS

2.1 MANUFACTURERS

A. Basis-of-Design: Subject to compliance with requirements, provide Super ThoroSeal® T5010 manufactured by Thoro Consumer Products (BASF Construction Chemicals, LLC).

1. Color: Grey.

2.2 MATERIALS

A. A powder, cement-based waterproofing product for protecting concrete and masonry substrates.

2.3 ACCESSORIES

A. Supply all materials necessary for a complete and satisfactory installation of cement-based waterproofing system, including patching and crack repair materials.

PART 3 – EXECUTION

3.1 EXAMINATION

- A. Verification of Conditions.
1. Inspect all surfaces to receive cementitious coating. Verify that surfaces are dry, clean, and free of contaminants that would prevent coating from properly adhering to the surface.
 2. Before starting work report in writing any unsatisfactory conditions to the Architect.

3.2 SURFACE PREPARATION

- A. Prepare surfaces using methods recommended by the manufacturer for achieving the best result for the substrate under the project conditions.
- B. Create a surface profile to feel like 30 to 50 grit sandpaper.
- C. Clean Surfaces thoroughly prior to installation.
- D. Rout and clean moving cracks and joints: fill with manufacturer's recommended filler material.
- E. Repair any non-moving surface deviations with manufacturer's recommended patching material.

3.3 INSTALLATION

- A. Install coatings in accordance with manufacturer's instructions.
- B. Mix all materials in accordance with manufacturer's instructions.
- C. Use application equipment, tools, and techniques in accordance with manufacturer's instructions.
- D. Uniformly apply coatings at spread rates and in number of coats to achieve specified coverage.
- E. Adhere to all limitations, instructions, and cautions for cementitious coating as stated in the manufacturer's published literature

3.4 FIELD QUALITY CONTROL

- A. Verify coatings and other materials are as specified.
- B. Verify coverages and finish of the system as work progresses.
- C. Manufacturer's representative shall provide technical assistance and guidance for surface preparation and application of coating systems.

3.5 PROTECTION AND CLEAN-UP

- A. Installation areas must be kept free from traffic and other trades during the application procedure and cure time.
- B. Protect finished surfaces of coating system from damage during construction.
- C. Touch-up, repair or replace damaged flooring system after substantial completion.
- D. Clean area and remove all debris upon completion of work. Dispose of empty containers properly according to current local, state and federal regulations.
- E. Allow material to cure 4 to 6 hours before light pedestrian traffic is permitted, 24 hours before heavy traffic, and 72 hours before vehicular traffic is permitted.

3.6 MAINTENANCE

- A. Contractor shall provide to owner, maintenance and cleaning instructions for the cementitious coating system upon completion of work. Owner is required to clean and maintain the surfaces to maintain manufacturer's warranty.

END OF SECTION 09 97 26

SECTION 11 13 00

LOADING DOCK EQUIPMENT

PART 1 GENERAL

1.1 SUMMARY

- A. Section Includes:
 - 1. Dock Levelers.
 - 2. Truck Restraints.
 - 3. Dock Bumpers.
 - 4. Wheel Chocks

1.2 DEFINITIONS

- A. Operating Range: Maximum amount of travel above and below the loading dock level.
- B. Working Range: Recommended amount of travel above and below the loading dock level for which loading and unloading operations can take place.

1.3 SUBMITTALS

- A. Product Data: For each type of product indicates.
- B. Shop Drawings: For loading dock equipment. Include plans, elevations, sections, details, and attachments to other work.
 - 1. Detail equipment assemblies and indicate dimensions, weights, loads, required clearances, method of field assembly, components, and location and size of each field connection.
 - 2. Wiring and Conduit Diagrams: For all power, lighting, signal, and control wiring.
- C. Samples: For each fabric and for each color and texture specified.
- D. Welding Certificates.
- E. Product Test Reports.
- F. Warranty: Sample of special warranty.
- G. Operation and maintenance data.

1.4 QUALITY ASSURANCE

- A. Installer Qualifications: Manufacturer's authorized representative who is trained and approved for installation of units required for this Project.
- B. All products shall be from the same manufacturer.

- C. Welding Qualifications: Qualify procedures and personnel according to the following:
 - 1. AWS D1.1/D1.1M, "Structural Welding Code – Steel."
 - 2. AWS D1.3, "Structural Welding Code – Sheet Steel."
- D. Electrical Components, Devices, and Accessories: Listed and labeled as defined in NFPA 70, by a qualified testing agency, and marked for intended location and application. WI Licensed and Manufacturer Certified installation electrical contractor.
- E. Presinstallation Conference: Conduct conference at Project site.

1.5 DELIVERY, STORAGE, AND HANDLING

- A. Store products in manufacturer's unopened packaging until ready for installation.
- B. Store and dispose of solvent-based materials, and materials used with solvent-based materials, in accordance with requirements of local authorities having jurisdiction.

1.6 PROJECT CONDITIONS

- A. Maintain environmental conditions (temperature, humidity, and ventilation) within limits recommended by manufacturer for optimum results. Do not install products under environmental conditions outside manufacturer's limits.
- B. Field Measurements: Verify actual dimensions of construction contiguous with loading dock equipment, by field measurements before fabrication.

1.7 WARRANTY

- A. Special Warranty for Dock Levelers: Manufacturer's standard form in which manufacturer agrees to repair or replace dock-leveler components that fail in materials or workmanship within specified warranty period.
 - 1. Failures include, but are not limited to, the following.
 - a. Structural failures including cracked or broken structural support members, load-bearing welds, and front and rear hinges.
 - b. Faulty operation of operators, control system, or hardware.
 - c. Deck plate failures including cracked plate or permanent deformation in excess of 1/4 inch between deck supports.
 - d. Hydraulic system failures, including failure of hydraulic seals and cylinders.
 - 2. Warranty Period for Structural Assembly: 10 years from date of Substantial Completion.
 - 3. Warranty Period for Hydraulic System: Five years from date of Substantial Completion.
 - 4. Warranty shall be for unlimited usage of leveler for the specified rated capacity over the term of the warranty.

PART 2 PRODUCTS

2.1 MATERIALS

- A. Steel Plates, Shapes, and Bars: ASTM 36/A 36M.

- B. Rolled-Steel Floor Plate: ASTM A 786/A 786M, rolled from steel plate complying with ASTM A 572/A 572M, Grade 55.
- C. Steel Tubing: ASTM A 500, cold formed.
- D. Welding Rods and Bare Electrodes: Select according to AWS specifications for metal alloy welded.
- E. Wood: DOC PS 20 dimension lumber, select structural grade, kiln dried.
- F. Pressure-Treated Wood: DOC PS 20 dimension lumber, select structural grade, kiln dried, and pressure treated with waterborne preservatives to comply with AWWA C2.

2.2 RECESSED DOCK LEVELERS

- A. General: Recessed, hinged-lip-type dock levelers designed for permanent installation in concrete pits preformed in the edge of loading platform; of type, function, operation, capacity, size, and construction indicated; and complete with controls, safety devices, and accessories required.
 - 1. Manufacturers: Basis of Design, Rite-Hite RHH 7' X 8' - 40,000 lbs. Subject to compliance with requirements, or approved equal products by one of the following manufacturers:
 - a. Poweramp Equipment Corporation.
 - b. SPX Dock Products – Serco.
 - c. Blue Giant Equipment Corporation.
- B. Standard: Comply with MH 30.1, except for structural testing to establish rated capacity.
- C. Rated Capacity: Capable of supporting total gross load of 40,000 lbs without permanent deflection or distortion.
- D. Platform: Not less than 3/8-inch-thick, nonskid steel plate.
- E. Hinged Lip: Not less than 5/8-inch-thick, nonskid steel plate.
 - 1. Hinge: Full width, piano-type hinge with heavy-wall hinge tube and greased fittings, with gussets on lip and ramp for support.
 - 2. Safety Barrier Lip: Designed to protect material-handling equipment from an accidental fall from loading platform edge of the dock leveler when the leveler is not in use.
- F. Function: Dock levelers shall compensate for differences in height between truck bed and loading platform.
 - 1. Vertical Travel: Operating range above platform level of sufficient height to enable lip to extend and clear truck bed before contact with the following minimum working range.
 - a. Above Adjoining Platform: 18 inches.
 - b. Below Adjoining Platform: 12 inches.
 - 2. Automatic Vertical Compensation: Floating travel of ramp with lip extended

and resting on truck bed shall compensate automatically for upward or downward movement of truck bed during loading and unloading.

3. Automatic Lateral Compensation: Tilting of ramp with lip extended and resting on truck bed shall compensate automatically for canted truck beds of up to 4 inches (102 mm) over width of ramp.
 4. Lip Operation: Manufacturer's standard mechanism that automatically extends and supports hinged lip on ramp edge with lip resting on truck bed over dock leveler's working range, allows lip to yield under impact of incoming truck, and automatically retracts lip when truck departs.
 - a. Length of Lip Extension: 20 inches.
 5. Interlock: Combination control box. Leveler will not operate while, leveler night lock is engaged, truck restraint is not engaged, and inflatable dock seal is not inflated. Installed by Manufacturer including conduit.
- G. Hydraulic Operating System: Electric control from a remote-control station; fully hydraulic operation. Electric-powered hydraulic raising and hydraulic lowering of ramp. Equip leveler with a packaged unit including a unitized, totally enclosed, nonventilated electric motor, pump, manifold reservoir, and valve assembly of proper size, type, and operation for capacity of leveler indicated. Include means for lowering ramp below platform level with lip retracted behind dock bumpers. Provide a hydraulic velocity fuse connected to main hydraulic cylinder to limit loaded ramp's free fall to not more than 3 inches. Installed by Manufacturer including conduit, wiring and hydraulic lines.
1. Combination Remote-Control Station with Emergency Stop: Weatherproof multibutton control station with an UP button of the constant-pressure type and an emergency STOP button of the momentary-contact type, enclosed in NEMA ICS 6, Type 4 box. Ramp raises by depressing and holding UP button; ramp lowers at a controlled rate by releasing UP button. All ramp movement stops, regardless of position of ramp or lip, by depressing STOP button. Normal operation resumes by engaging a manual reset button or by pulling out STOP button. Interlock: Combination interlock control box. Leveler will not operate while truck restraint is not engaged. Installed by manufacturer including conduit.
 2. All power and control conduit and wire provided and installed by the Loading Dock Equipment Trade Contractor.
- H. Construction: Fabricate dock-leveler frame, platform supports, and lip supports from structural- or formed-steel shapes. Weld platform and hinged lip to supports. Fabricate entire assembly to withstand deformation during both operating and stored phases of service. Chamfer lip edge to minimize obstructing wheels of material-handling vehicles.
1. Cross-Traffic Support: Manufacturer's standard method of supporting ramp at platform level in stored position with lip retracted. Provide a means to release supports to allow ramp to descend below platform level.
 2. Maintenance Strut: Integral strut to positively support ramp in up position during maintenance of dock leveler.

- I. Integral Laminated-Tread Dock Bumper: Fabricated from 6-inch- thick 20 inches wide, multiple, uniformly thick plies cut from fabric-reinforced rubber tires. Laminate plies under pressure on not less than two 3/4-inch- (19-mm-) diameter, steel supporting rods that are welded at one end to 1/4-inch- (6-mm-) thick, structural-steel end angle and secured with a nut and angle at the other end. Fabricate angles with predrilled anchor holes and sized to provide not less than 1 inch (25 mm) of tread plies extending beyond the face of closure angles.
- J. Accessories:
 - 1. Toe Guards: Paint yellow to comply with ANSI Z535.1.
 - 2. Self-Forming Pan: Manufacturer's standard prefabricated, self-forming steel form system for poured-in-place construction of concrete pit.
 - 3. Night Locks: Manufacturer's standard means to prevent extending lip and lowering ramp when overhead doors are locked.
 - 4. Side and rear weatherseals.
 - 5. Foam insulation under dock-leveler platform.
 - 6. Abrasive skid-resistant surface.
 - 7. 7" leveler barrier
- K. Finish: Hot-dip galvanize dock levelers after assembly and testing.
 - 1. Toe Guards: Paint yellow to comply with ANSI Z535.1.

2.3 TRUCK RESTRAINTS

- A. General: Manufacturer's standard device designed to engage truck's rear-impact guard and hold truck at loading dock. Restraint shall consist of an iron or steel restraining arm that raises until contacting rear-impact guard. Arm shall move vertically, automatically adjusting to varying height of truck due to loading and unloading operations.
 - 1. Manufacturers: Basis of Design Rite-Hite FHR shadow hook. Subject to compliance with requirements, provide products by one of the following manufacturers:
 - a. Poweramp Equipment Corporation.
 - b. SPX Dock Products – Serco.
 - c. Blue Giant Equipment Corporation.
- B. Standard: Comply with MH 30.3.
- C. Rated Capacity: Capable of supporting total gross load without permanent deflection or distortion.
- D. Operating Range: Capable of restraining rear-impact guards within a range from:
 - 1. Vertical: 12 inches above driveway.
 - 2. Horizontal: 12 inches in front of dock bumpers.
- E. Power Operating System: Manufacturer's standard electromechanical or hydraulic unit.

1. Remote-Control Station: Single-button station of the constant-pressure type, enclosed in NEMA ICS 6, Type 12 box. Restraint is engaged by depressing and holding button; restraint is released by releasing button. Installed by manufacturer including conduit.
 2. Interlock: Combination control box. Leveler will not operate while truck restraint is not engaged. Installed by manufacturer including conduit.
 3. All power and control conduit and wire provided and installed by the Loading Dock Equipment Trade Contractor.
- F. Caution Signs: Exterior, surface mounted; designed to inform both dock attendant and truck driver; with sign copy as follows. Provide one sign at each truck-restraint location.
1. Sign Copy in Forward and Reverse Text: Manufacturer's standard text permitting truck movement with green light.
 2. Interior Sign Copy: Manufacturer's standard text permitting truck movement with green light.
- G. Light-Communication System: Red and green illuminated signal-light sets, with lens approximately 4 inches in diameter, designed to indicate status to both dock attendant and truck driver. Equip system with steel control panel located at interior of dock that indicates status of exterior signal lights. Provide signal-light set and control panel at each location indicated for light-communication system. Enclose exterior signal-light sets in steel or plastic housing with sunshade. Installed by manufacturer including conduit.
1. Automatic Operation: System is activated automatically when device engages rear-impact guard. Provide on-off switch located on truck-restraint control panel.
 2. Mounting: Dock Pit Wall.
 3. All power and control conduit and wire provided and installed by the Loading Dock Equipment Trade Contractor.
- H. Alarm: Audible and visual system indicating that rear-impact guard is not engaged, with manual reset. Installed by Manufacturer including conduit.
- I. Accessories: Combination Interlock to dock leveler. Installed by Manufacturer including conduit. All power and control conduit and wire provided and installed by the Loading Dock Equipment Trade Contractor.
- J. Truck-Restraint Finish: Hot-dip galvanized.

2.4 DOCK BUMPERS

- A. Manufacturers: Subject to compliance with requirements, provide products by one of the following manufacturers:
 - 1. Rite-Hite Corporation.
 - 2. Poweranp Equipment Corporation.
 - 3. SPX Dock Products – Serco.
 - 4. Blue giant Equipment Company.

- B. Steel-Face, Laminated-Tread Bumpers: Fabricated from multiple, uniformly thick plies cut from fabric-reinforced rubber tires and with 3/8-inch (9.5-mm) steel face plate of same size as rubber surface. Laminate plies under pressure on not less than two 3/4-inch diameter, steel supporting rods that are welded at one end to 1/4-inch-thick, structural-steel end angle and secured with a nut and angle at the other end. Fabricate angles with predrilled anchor holes and sized to provide not less than 1 inch of tread plies extending beyond the face of closure angles. Weld face plate to two steel support brackets, which shall extend back to and engage 3/4-inch-diameter support rods in elongated holes, allowing steel face to float on impact.
 - 1. Thickness: 6 inches by 20 inches long

- C. Anchorage Devices: Hot-dip galvanized-steel anchor bolts, nuts, washers, bolts, sleeves, cast-in-place plates, and other anchorage devices as required to fasten bumpers securely in place and to suit installation type indicated.

2.5 WHEEL CHOCKS

- A. Manufacturers: Provide Wheel Chocks and galvanized chains. One per docking station. Subject to compliance with requirements, provide products by one of the following manufacturers:
 - 1. Rite-Hite Corporation.
 - 2. Rol-Lift Corporation.
 - 3. SPX Dock Products – Serco.
 - 4. Approved Equal.

2.6 PRE-MANUFATURER BOLLARDS AND BOLLARD SLEEVES

- 1. Provide and install pre-manufactured, pre-finished column protection as indicated in the Drawings, by A-SAFE products Inc. or approved equal. Include 3 vertical pipes and 3 horizontal rails.
- 2. Provide and install HDPE bollard sleeves as indicated on the Drawings. Color, Orange.
- 3. Other Bollards are required and provided under Division 5, see Drawings.

2.7 STEEL FINISHES

- A. Galvanizing: Hot-dip galvanize components as indicated to comply with the following.
 - 1. ASTM A 123/A 123M for iron and steel loading dock equipment.

2. ASTM A 153/A 153M or ASTM F 2329 for iron and steel hardware for loading dock equipment.
- B. Galvanized-Steel and Steel Finish: Immediately after cleaning and pretreating, apply manufacturer's standard two-coat, baked-on finish consisting of prime coat and thermosetting topcoat in manufacturer's standard color.

PART 3 EXECUTION

3.1 INSTALLATION

- A. Examine roughing-in for electrical systems for loading dock equipment to verify actual locations of connections before equipment installation.
- B. Examine walls and floors of pits for suitable conditions where recessed loading dock equipment is to be installed. Pits shall be plumb and square and properly sloped for drainage from back to front of loading dock.
- C. Set curb angles in concrete edges of dock-leveler recessed pits with tops flush with loading platform. Fit exposed connections together to form hairline joints.
- D. Place self-forming pan system for recessed dock levelers in proper relation to loading platform before pouring concrete.
- E. Install loading dock equipment, including motors, pumps, control stations, wiring, safety devices, light-communication systems, and accessories as required for a complete installation.
 1. Rough-in electrical connections.
- F. Recessed Dock Levelers: Attach dock levelers securely to loading dock platform, flush with adjacent loading dock surfaces and square to recessed pit.
- G. Truck Restraints: Attach truck restraints in a manner that complies with requirements for arrangement and height required for device to engage vehicle rear-impact guard. Interconnect control panel and signals with dock leveler.
 1. Pit-Mounted Units: Anchor truck restraints to driveway with expansion anchors and bolts.
- H. Dock Bumpers: Attach dock bumpers to face of loading dock in a manner that complies with requirements indicated for spacing, arrangement, and position relative to top of platform and anchorage.
 1. Welded Attachment: Plug-weld anchor holes in contact with steel inserts and fillet weld at other locations.
 2. Bolted Attachment: Attach dock bumpers to preset anchor bolts embedded in concrete or to cast-in-place inserts or threaded studs welded to embedded-steel plates or angles. If preset anchor bolts, cast-in-place inserts, or threaded studs welded to embedded-steel plates or angles are not provided, attach dock bumpers by drilling and anchoring with expansion anchors and bolts.

- I. Adjust loading dock equipment to function smoothly and safely, and lubricate as recommended by manufacturer.
- J. Test dock levelers and lifts for vertical travel within operating range indicated.

3.2 DEMONSTRATION

- A. Train Owner's maintenance personnel to adjust, operate, and maintain loading dock equipment.

3.3 PROTECTION

- A. Protect installed products until completion of project.
- B. Touch-up, repair or replace damaged products before Substantial Completion.

END OF SECTION 11 13 00

Page Intentionally Left Blank

SECTION 22 00 00

PLUMBING

PART 1 - GENERAL

1.01 DESCRIPTION

- A. Work Included: Provide plumbing where shown on the Drawings, as specified herein, and as needed for a complete and proper installation including, but not necessarily limited to:
1. Exterior Storm Water piping;
 2. Exterior Storm Water Catch Basin and Grate;
 3. Existing Manhole Alterations.
- B. Related Work:
1. Documents affecting work of this Section include, but are not necessarily limited to, General Conditions, Supplementary Conditions, and Sections in Division 1 of these Specifications.
 2. Cutting and patching existing exterior paving and hard surfaces for site utilities by the Plumbing Contractor.
- C. Work of Other Sections:
1. Openings for new Plumbing work in new construction walls, floors, roof, ceiling, etc. shall be provided by the General Contractor. Location and size of these openings shall be the responsibility of the Plumbing Contractor.
 2. Roofing, exterior wall and related exterior openings shall be caulked, sealed and patched by the General Contractor.

1.02 GENERAL PROVISIONS

- A. This specification Section is a general description of the work requirements. The particular descriptions are not intended to be all inclusive. Bidders shall also refer to the Drawings.
- B. Prior to submitting a bid, the Contractor shall call the Engineer's attention (in writing only) to any materials or items of work believed to be inadequate. Bidders are required to visit the premises, take measurements, inspect existing conditions and limitations, and obtain first hand information necessary to submit a bid. The intent of the Contract is to obtain complete system installations, tested, ready for operation. No extras will be allowed because Contractor's misunderstanding of the scope work involved.
- C. Everything essential for the completion of the work implied to be covered by these Specifications to make the system ready for normal and proper operation must be furnished and installed by this Contractor. Accordingly, any omission from either the plans or the Specifications, or both of details necessary for the proper installation and operation of the system shall not relieve this Contractor from furnishing such detail in full and proper manner.
- D. The Drawings show various details indicating the general arrangement of the plumbing work, sizes and locations of piping, equipment, etc. The said Drawings with figures, lettering, etc., shall be considered a part of these Specifications and no charge or alternation shall be made in any case unless ordered by the Engineer.

- E. In addition to the Plumbing work, refer to the Plumbing work shown on the general Construction Drawings of the building as being part of this Contract, unless specified to be completed by other contractors.

1.03 QUALITY ASSURANCE

- A. Use adequate number of skilled workmen who are thoroughly trained and experienced in the necessary crafts and who are completely familiar with the specified requirements and the methods needed for proper performance of the work of this Section.
- B. Without additional cost to the Owner, provide such other labor and materials as required to complete the work of the Section in accordance, with the requirements of governmental agencies having jurisdiction, regardless of whether such materials and associated labor are called for elsewhere in the Contract Documents.
- C. In acceptance or rejection of installed work, the Architect or Engineer shall make no allowance for lack of skill on the part of the Workmen.
- D. For the actual field fabrication, installation and testing of the Plumbing work, use only thoroughly trained and experienced workmen complete familiar with the items required and manufacturer's current recommended methods of installation.
- E. Reference Standards:

ANSI	American National Standards Institute
ASME	American Society of Mechanical Engineers
ASSE	American Society of Sanitary Engineering
ASTM	American Society of Testing and Material
AWWA	American Waterworks Association
CISPI	Cast Iron Soil Pipe Institute
FM	Factory Mutual
MCA	Mechanical Contractors Association
NEC	National Electric Code
NEMA	National Electrical Manufacturers Association
NFPA	National Fire Protection Association
NSF	National Sanitation Foundation
WQA	Water Quality Association

1.04 CODES AND PERMITS

- A. This contractor must comply with building codes and other ordinances in force where the building is located as far as it apply to his work.
 - 1. Engineer will provide approved plumbing plans from the Municipality or State having jurisdiction.
- B. Plumbing work shall meet all Federal, State, Local Codes, ordinances and utility regulations.
 - 1. In the event of conflict between or among specified requirements and pertinent regulations, the more stringent requirement will govern when so directed by the Engineer.
- C. Plumbing Contractor must secure permits from proper offices and pay all legal fees as may be necessary for fulfilling the requirements of these specifications.

- D. Submit one (1) copy of all permits to the Owner.

1.05 COORDINATION

- A. Cooperate and coordinate with other trades to assure that all systems pertaining to the Plumbing work shall be installed in the best feasible arrangement. Coordinate as required with all other trades to share space in common areas and to provide the maximum of access to each system.
- B. Arrange plumbing work in neat, well organized manner with piping and similar services running with primary lines of building construction, and with minimum of 8 foot overhead clearance, where possible.
- C. Locate equipment properly to provide easy access, and arrange entire Plumbing Work with adequate access for operation and maintenance.
- D. Give right-of-way to piping which must slope for drainage.
- E. Where Plumbing work is to connect to existing, the Contractor must field verify all connection points before beginning any rough-in work. Verify gravity flow lines and proper invert elevations required prior to starting piping installation.
- F. Coordinate site utility requirements with General Contractor, along with inverts required to building.

1.06 CUTTING AND PATCHING

- A. General: Refer to Division 1 General Requirements.
- B. Perform all cutting and patching required for complete installation of the HVAC systems, unless specifically noted otherwise. Provide all materials required for patching unless otherwise noted.
 - 1. All cutting and patching necessary of structural members to install any plumbing work shall not be done without permission, and then only carefully done under the direction of the Architect and General Contractor.
- C. The Contractor shall not endanger any work of other trades by a demolition, cutting, digging or otherwise. Any cost caused by defective or ill-timed cutting and patching work shall be borne by the contractor responsible. Each contractor requiring cutting and patching shall hire men skilled in such cutting and patching to do the work.
 - 1. All patching work in existing areas shall match existing work and restore the finish to its original condition in material, quality, texture, finish and color unless specifically noted or scheduled otherwise.

1.07 TESTS AND INSPECTIONS:

- A. All plumbing tests shall be conducted in the presence of and to the satisfaction of the Governing Authorities, Architect/ Engineer, and Owner or his authorized representative.
- B. The Plumbing Contractor shall be responsible for applying tests and ordering inspections as required by Federal, State and local Code and Inspection authorities.
 - 1. All work shall remain exposed until it has been tested, inspected and approved.

1.08 TEMPORARY SERVICES

- A. Provide temporary services for all plumbing services to the existing facility to maintain function of sanitary, storm, natural gas and water services during the construction period.

1.09 TRENCHING AND BACKFILLING

- A. Trench, excavate and tunnel to place all piping and other related work necessary at the elevations indicated or required, as shown on the Drawings.
 - 1. Cut bottom of trench to grade, make trench 12” wider than the widest dimension of the pipe.
 - 2. All pipes shall be laid on a compacted bed of sand 6” deep. Do not lay piping on large stones, rocks or bricks.
- B. Backfill in layers and compact sufficiently to prevent settlement. Backfill with damp sand and fine gravel mixture.
 - 1. Exterior locations shall be backfilled to 12” of grade with sand and fine gravel mixture and the remainder with native compacted topsoil.
 - 2. Do not start backfill operations until plumbing work has been properly inspected and approved.

1.10 CONCRETE FOR PLUMBING WORK

- A. General: Comply with pertinent provisions of Division 1 and Division 3.
- B. All concrete work for equipment pads by the Plumbing Contractor.
- C. Concrete Equipment Pads: For each piece of floor or ground mounted plumbing equipment as indicated on the Drawings, provide a 4” concrete housekeeping pad at a minimum of 4 inches wider than the full size of the respective equipment’s base. Equipment pads are required for the following equipment:
 - 1. Storm Catch Basin.

1.11 SUBMITTALS

- A. Refer to Division 1 for additional submittal requirements.
- B. The Plumbing Contractor will be held responsible for correction of work deemed necessary by the Engineer due to proceeding with the work without shop drawings that have the Architect/Engineers final approval.
- C. Shop drawings shall include data on physical dimensions, gauges, materials of construction and capacities.
 - 1. Incomplete drawings will be disapproved.
- D. This Contractor will be responsible for all figures and dimensions shown on the shop drawings. Approval of shop drawings describing equipment that cannot fit in the space allotted does not relieve this Contractor from providing equipment that will meet the space requirements.
- E. Submit six (6) copies of shop drawings to the Architect/Engineer for approval, with complete detail for all equipment, materials, etc., to be furnished and installed for this project as follows:
 - 1. Manholes, Grates and Accessories;

2. Catch Basins and Grates;
 3. Pipe and piping specialties;
 4. As-built Drawings(1 copy).
- F. Submit to the local building authority for approval: equipment cuts, O&M manuals, Installation manuals, and any UL listed assemblies employed to penetrate fire-rated assemblies.

1.12 AS-BUILT DRAWINGS

- A. During construction maintain a set of prints showing installed as-built work for the project.
- B. Upon completion of construction before final acceptance, provide a set of as-built drawings to the Architect/Engineer.

PART 2 - PRODUCTS

2.01 STORM DRAIN PIPE SCHEDULE

- A. PVC PIPE: Conform to ASTM D-3034 with solvent weld or elastomeric joints. Pipe shall be SDR-35, unless otherwise noted. Pipe over 15 inches in diameter shall meet the requirements of ASTM F679-03. Do not mix different manufacturer's products, or fittings.
 1. PVC fitting joint type and SDR shall be same as the pipe that the fitting is connected to.

2.02 MANHOLES AND CATCH BASINS

- A. MANHOLES AND CATCH BASINS: Provide precast concrete manholes and catch basins.
 1. Contractor shall carefully locate all pipe locations, sizes, orientation and elevation prior to ordering new manholes and catch basins.
- B. Precast Manhole and Catch Basin Sections: Precast concrete manhole and catch basin sections, including bottom and top shall meet the requirements of ASTM C478.
 1. Unless otherwise noted, provide four 4' diameter manholes.
 2. For 4' diameter manholes, provide eccentric cone top sections with a minimum clear opening of 24 inches. Flat top slabs may be used on manholes greater than 4' in diameter.
 3. Manhole wall thickness shall be minimum of 5" for 4' diameter manholes, 6" for 5' diameter manholes and 7" for 6' and 7' diameter manholes.
 4. Manhole bottom section shall be pre-cast with integral base having a minimum thickness of 8" unless otherwise noted.
- C. Joints: Provide manhole riser and barrel sections, cones, and flat tops, with standard pipe section tongue and groove joints.
 1. Seal joints watertight with prefabricated rubber or plastic gaskets or formed in place butyl rubber seal.
 2. Joint sealers: Kent Seal, ConSeal, or approved equal.
- D. Connections: Openings for connections shall be cast-in-place or cored and appropriately sized for the type and size of pipe being connected.
 1. Provide flexible, watertight, pipe-to-manhole connections (or "boots") for sanitary sewers; Kor-N-Seal, Interpace, A-Lok, or an approved equal.

- E. **Bench and Flowline:** Provide either pre-cast or cast-in-place bench and flowline.
1. Unless otherwise indicated on the drawings, bench height shall be $\frac{3}{4}$ the diameter of the downstream pipe. Slope bench towards flowlines at a minimum $\frac{1}{2}$ " per foot. Provide light broom finish on bench.
 2. Flowlines shall be formed with gradual, uniform sweeps directed towards the downstream pipe. Provide smooth, troweled finish for flowlines.
 3. When cast-in-place benches and flowline are used, lay the sewer pipe through the manhole.
- F. **Adjusting Rings**
Fiber-reinforced pre-cast concrete adjusting rings meeting the requirements of ASTM C-478. Provide rings of 2" or 4" thickness.
- G. **Gaskets:** Precompressed butyl gasket: 3/8"x3 1/2" shall be used between the top of the manhole and first adjustment ring, and between all subsequent rings. Butyl material shall be E-Z Stick, or equal.

2.03 CASTINGS

- A. **General:** All manhole castings shall be heavy duty iron conforming to ASTM A48, Class 20 and rated for AASHTO H-20 loading. Provide water-tight, gasketed, self-sealing, non-rocking lids with concealed pickhole.

2.04 OTHER MATERIALS

- A. Provide other materials, not specifically described but required for a complete and proper installation, as selected by the Contractor subject to the approval of the Architect.

PART 3 - EXECUTION

3.01 SURFACE CONDITIONS

- A. Examine the areas and conditions under which work of this Section will be performed. Correct conditions detrimental to timely and proper completion of the Work. Do not proceed until unsatisfactory conditions are corrected.

3.02 PLUMBING SYSTEM LAYOUT

- A. Lay out the plumbing system in careful coordination with the Drawings, determining proper elevations for all components of the system and using only the minimum number of bends to produce a satisfactorily functioning system.
- B. Follow the general layout shown on the Drawings in all cases except where other work may interfere.
- C. Lay out pipes to fall within partition, wall, or roof cavities, and to not require furring other than as shown on the Drawings.
- D. Where work is to connect to existing, Plumbing contractor must field verify all connection points before beginning any rough-in work. Verify all connecting invert elevations and flow lines of new work connected to existing gravity drainage.

3.03 TRENCHING AND BACKFILLING

- A. Perform trenching and backfilling associated with the work of this Section in strict accordance with the provisions of Division 2 of these Specifications.

- B. Cut bottom of trenches to grade. Make trenches 12" wider than the greatest dimension of the pipe.
- C. Bedding and backfilling:
 - 1. Install piping promptly after trenching. Keep trenches open as short a time as practicable.
 - 2. Under the building, install pipes on a 6" bed of damp sand. Backfill to bottom of slab with damp sand.
 - 3. Outside the building, install underground piping on a 6" bed of damp sand. Backfill to within 12" of finish grade with damp sand. Backfill remainder with native topsoil.
 - 4. Do not backfill until installation has been approved and until Project Record Documents have been properly annotated.

3.04 INSTALLATION OF PIPING

- A. General:
 - 1. Proceed as rapidly as the building construction will permit.
 - 2. Thoroughly clean items before installation. Cap pipe openings to exclude dirt until fixtures are installed and final connections have been made.
 - 3. Cut pipe accurately, and work into place without springing or forcing properly clearing window, doors, and other openings. Excessive cutting or other weakening of the building will not be permitted.
 - 4. Show no tool marks or threads on exposed plated, polished, or enameled connections from fixtures. Tape all finished surfaces to prevent damage during construction.
 - 5. Make changes in directions with fittings; make changes in main sizes with eccentric reducing fittings. Unless otherwise noted, install water supply and return piping with straight side of eccentric fittings at top of the pipe.
 - 6. Run horizontal sanitary piping at a uniform grade of 1/8" per ft., unless otherwise noted. Run horizontal water piping with an adequate pitch upwards in direction of flow to allow complete drainage.

3.05 MANHOLES AND CATCH BASINS

- A. Contractor shall determine the proper location, size, elevation, and orientation of all pipes entering new manholes before ordering. Do not connect abandoned pipes to new manholes. Manholes and catch basins having improper location and/or orientation of the pipe connections will be rejected. Field repairs or adjustments of connection points are not permitted.
- B. Limit the excavation for manholes and catch basins so as to provide only the necessary amount of space to sufficiently prepare the subgrade, set the base, set the manhole or structure, and lay pipe. Provide a minimum of 1' of clearance between structure and trench wall for adequate backfilling and compaction.
- C. Where excavation occurs below the bottom elevation of the structure's base, bring the excavation to the required elevation by the use of compacted crushed stone bedding. A minimum of 8 inches of compacted crushed stone bedding shall be placed below manhole base.
- D. Set manhole or catch basin base in accordance with elevation and location as indicated on the plans. Install base plumb and level. Install subsequent pre-cast manhole sections in accordance with shop drawing layout. Provide watertight gaskets between each manhole section.
- E. Pour inverts with smooth surface draining to downstream pipe. Where two or more lines meet at an angle, provide curved channel. Slope manhole bench at 2 inches/ft towards flow channel.

- F. Manholes shall be provided with between 4” and 8” of adjusting rings, with the top adjusting ring being 2” thick. Provide butyl sealant material between rings. Once rings are in place, tuck point the exterior joint and provide the entire exterior surface of the adjusting ring riser with a coating of mortar.
1. When indicated on the drawings, the manhole frame shall be set with a Type I frame/chimney joint as specified in the Standard Specifications for Sewer and Water Construction in Wisconsin, latest edition.
 2. The frame and adjusting rings shall be sealed with an internal rubber sleeve as detailed in File 12A of the Standard Specifications.
 3. Drop manholes shall be constructed in accordance with File No. 19 of the Standard Specifications.

2.06 CASTING INSTALLATION

- A. Install casting type as indicated on the plans or in the specifications.
- B. Provide butyl sealant material between last adjusting ring and casting base. Adjust casting elevation and slope to match adjacent proposed grades.

2.07 CONNECTIONS TO EXISTING STRUCTURES

- A. Make all necessary openings into existing structures or sewers including the reconstruction of existing inverts or benches, as necessary. Patch all openings permanently watertight with concrete brick and mortar, or hydraulic cement and waterstops, or for sanitary/storm sewers, hydraulic cement and flexible watertight boots.

2.08 SEWER LATERALS

- A. Connect existing sewer laterals in accordance with all of the requirements of the sewer mains, including bedding, backfill, compaction, and jointing of the pipe. Connect sewer laterals to the sewer main by means of an approved "wye" fitting. Connect the new pipe to the existing lateral material using a no-hub coupling or approved transition fitting. Coupling/fitting shall be selected for the specific pipe material being connected.
- B. Subject to local municipality requirements, cut-in type saddle wyes are permitted on existing sanitary sewers where service laterals are to be connected to the sewer. Unless otherwise indicated, the saddle fitting shall be gasketed PVC, with stainless steel bands and hardware.

3.09 LOCATOR TAPE

- A. Provide locator tape when indicated on the Drawings. Install locator tape approximately 2’ above the top of the pipe.

3.10 OTHER TESTING AND ADJUSTING

- A. Provide personnel and equipment, and arrange for and pay the costs of, all required tests and inspections required by governmental agencies having jurisdiction.
- B. Where test show materials or workmanship to be deficient, replace or repair as necessary, and repeat the tests until the specified standards are achieved.

END OF SECTION

SECTION 26 00 00

ELECTRICAL

PART 1 - GENERAL

1.01 DESCRIPTION

A. Work Included: Provide complete electrical service and distribution system with equipment and materials where shown on the Drawings, as specified herein, and as needed for a complete and proper installation including, but not necessarily limited to:

1. New electrical distribution equipment;
2. Grounding and Bonding;
3. Branch circuit wiring, for lighting, receptacles, motors and equipment;
4. Wiring devices and related equipment;
5. Lighting fixtures;
6. Hangers, anchor sleeves, chase supports for fixtures, and other electrical materials and equipment in association therewith;
7. Other items and services required to complete the electrical systems.

B. Related Work:

1. Documents affecting work of this Section include, but are not necessarily limited to, General Conditions, Supplementary Conditions, and Sections in Division 1 of these Specifications;
2. Refer to Division 00 project bidding requirements for alternates and related requirements.

C. Work of Other Sections:

1. Low-voltage (less than 100 volts) controls for General Construction, Plumbing, and HVAC trades.

1.02 GENERAL PROVISIONS

A. Everything essential for the completion of the work implied to be covered by these Specifications to make the system ready for normal and proper operation must be furnished and installed by this Contractor. Accordingly, any omission from either the plans or the Specifications, or both, of details necessary for the proper installation and operation of the system shall not relieve this Contractor from furnishing such detail in full and proper manner.

B. In addition to the electrical plans, see General Plans of the building, as all electrical work appearing on the latter plans will be part of this contract unless especially specified to be done by other contractors, as well as, the said work detailed on the electrical plans.

1.03 QUALITY ASSURANCE

A. Use adequate numbers of skilled workmen who are thoroughly trained and experienced in the necessary crafts and who are completely familiar with the specified requirements and methods needed for proper performance of the work of this Section.

B. Without additional cost to the Owner, provide such other labor and materials as required to complete the work of this Section in accordance with the requirements of governmental agencies having jurisdiction, regardless of whether such materials and associated labor are called for elsewhere in these Contract Documents.

C. Reference Standard: The following standards are imposed, as applicable to the work:

ASTM	American Society of Testing and Materials
NEC	National Electrical Code
NEMA	National Electrical Manufacturers Association
NFPA	National Fire Protection Association
UL	Underwriters Laboratories
UL 50	Standards for enclosures for electrical equipment
UL 67	Standards for panelboards
UL 489	Standards for molded-case circuit breakers
NEMA AB 1	Standards for molded case circuit breakers
NEMA PB 1	Standards for panelboards

1.04 CODES AND PERMITS

A. The Contractor must comply with national, state of Wisconsin and electrical codes and other ordinances in force where the building is located as far as same apply to his work.

1. IBC 2009;
2. IEEC 2009;
3. NEC 2008;
4. Wisconsin Electrical Code SPS sections.

B. He must secure permits from proper offices and pay fees as may be necessary for fulfilling the requirements of these Specifications.

C. One (1) copy of all permits must be furnished to the Owner.

1.05 COORDINATION

A. Cooperate and coordinate with other trades to assure that all systems in the electrical work may be installed in the best arrangement. Coordinate as required with all other trades to share space in common areas and to provide the maximum of access to each system.

B. Arrange electrical work in neat, well-organized manner with piping and similar running parallel with primary lines of building construction.

C. Locate operating and control equipment properly to provide easy access, and install entire electrical systems with adequate access for operation and maintenance.

D. Give right-of-way to piping which must slope for drainage.

1.06 ELECTRICAL PROVISIONS OF THE MECHANICAL WORK

A. Line Voltage Wiring: The Electrical Contractor shall make all line voltage (100 volts and greater) electrical wiring, final connections and motor wiring for Mechanical equipment.

B. Control Wiring: Low-voltage (less than 100 volts) control wiring in conjunction with Mechanical work shall be by the Mechanical Contractor in strict accordance with the applicable sections of the Electrical Specifications.

- C. Motors, Starters, and Disconnects: All motors starter and disconnects shall be provided by the Electrical Contractor, unless provided with the equipment or indicated otherwise.
 - 1. Mechanical Contractors shall furnish list of and location of all Mechanical equipment and requirements for electrical connections, along with wiring diagrams.

1.07 FLOOR, WALL, ROOF AND CEILING OPENINGS

- A. The General Contractor will be required to leave openings in new construction ceiling, floors, walls, roof, partitions, etc., as required to install the Electrical work specified or shown on the Drawings. The Electrical Contractor is responsible for correct size and location of openings.
- B. Provisions for openings, holes and clearances through new construction walls, floors, ceilings and partitions are to be made in advance of construction of such parts of the building.
- C. The Electrical Contractor shall set sleeves and anchors for all equipment, etc., and shall provide watertight seals on pipes through exterior walls, floors and roof locations, and where noted on the Drawings.
- D. Pack annular space between sleeves and conduit with fiberglass insulation and seal with caulk. Where penetrations through fire rated walls or floors, seal openings with UL approved fire-stopping sealant/caulk assembly.

1.08 CUTTING AND PATCHING

- A. General: Refer to Division 1 General Requirements.
- B. Perform all cutting and patching required for complete installation of the Electrical systems, unless specifically noted otherwise. Provide all materials required for patching unless otherwise noted.
 - 1. All cutting and patching necessary of structural members to install any Electrical work shall not be done without permission, and then only carefully done under the direction of the Architect and General Contractor.
- C. The Contractor shall not endanger any work of other trades by demolition, cutting, digging or otherwise. Any cost caused by defective or ill-timed cutting and patching work shall be borne by the contractor responsible. Each contractor requiring cutting and patching shall hire men skilled in such cutting and patching to do the work.
 - 1. All patching work in existing areas shall match existing work in material, quality, texture, finish and color unless specifically noted or scheduled otherwise.

1.09 TRENCHING AND BACKFILLING

- A. Comply with pertinent provisions of Division 1.
- B. Perform trenching and backfilling associated with the work of this Section in strict accordance with the provisions of Division 2 of the Specifications.

1.10 SUBMITTALS

- A. Comply with pertinent provisions of Division 1.

B. Shop Drawing Submittals: Submit electronic shop drawings to the Architect for approval, with complete detail for all equipment, materials, etc., to be furnished and installed for this project as follows:

1. Light Fixtures.
2. Electrical Devices.
3. Electric Distribution Equipment.
4. Electrical Boxes and Raceways.

C. Shop Drawings:

1. The Electrical Contractor will be held responsible for correction of work deemed necessary by the Engineer due to proceeding with the electrical work without approved shop drawings that have the Architect/Engineers final approval.
2. Shop drawings shall include data on physical dimensions, gauges, materials of construction and capacities. Incomplete drawings will be disapproved.
3. This Contractor will be responsible for all figures, quantities and dimensions shown on the shop drawings.
4. Approval of shop drawings describing equipment that cannot fit in the space allotted does not relieve this Contractor from responsibility of resubmitting equipment that will meet the space requirements.

D. O & M Manual: Upon completion of this portion of the Work, and as a condition of its acceptance, deliver to the Architect two (2) copies of an operation and maintenance manual compiled in accordance with the provisions of Division 1 of these Specifications. Include the following within the bound O&M manual:

1. Copy of the approved Record Documents for this portion of the Work;
2. Copies of all circuit directories;
3. Copies of all warranties and guaranties.
4. As-built drawings.

E. As-built Drawings: Record installation as-built on a set of drawings prints in red during construction. Plan shall represent actual locations, materials and circuiting of equipment installed.

1.11 PRODUCT HANDLING

A. Comply with pertinent provisions of Division 1.

1.12 WARRANTY

A. In addition to standard one year warranty on all labor and materials, provide an additional warranty on ballasts for all new fluorescent and HID lighting fixtures as specified.

1.13 HOUSEKEEPING AND CLEAN-UP

A. Periodically as work progresses and/or as directed by the Architect, the Contractor shall remove waste materials from the building and leave the area of the workroom clean. Upon completion of work remove all tools, scaffolding, broken and waste materials, etc., from the site.

1.14 TEMPORARY SERVICES

A. This Contractor shall provide temporary lighting and power as required throughout the construction period.

- B. Arrange for temporary electrical utility with local electrical utility. Electrical Contractor shall pay all temporary electrical service and usage fees.

PART 2 - PRODUCTS

2.01 GENERAL

- A. Provide only materials that are new, of the type and quality specified. Where Underwriters' Laboratories, Inc. have established standards for such materials, provide only materials bearing the UL label.

2.02 BEDDING AND COVER MATERIAL

- A. Bedding and cover material shall be approved bedding sand with 100% of material passing a 3/8" sieve. No native material from trench shall be used for bedding or cover material. Unwashed bank run sand and crushed bank run gravel will be considered generally acceptable cover material.

2.03 BACKFILL MATERIALS

- A. Contractor shall backfill and compact trenches outside structure and structures zone of influence (ZOI) with excavated material, as long as it is free of cinders, ashes, refuse, rocks, boulders, or other such unsuitable materials and in the opinion of the Engineer is considered suitable.
- B. Contractor shall backfill and compact trenches within structure and structures ZOI with Low Frost Susceptibility Granular Fill consisting of granular material having less than 5 percent passing a No. 200 U.S. standard sieve or 3/4 inch clear stone.

2.04 SERVICE ENTRANCES AND METERING

A. Distribution Panels:

1. Existing Panelboard: 225-amp, 3-phase main distribution panel to be utilized to subfeed new panelboard 'LD' serving the loading dock as indicated on the plans.

2.05 GROUNDING SYSTEM

- A. Ground all equipment, including switches, transformers, conduit systems, motors, and other apparatus, by conduit or conductor to cold water main and to independent electrode, using ground clamps manufactured by Burndy or T&B, and approved by the Engineer.
- B. Existing service ground to be reused.
- C. Provide grounding jumper from electrical devices to the metallic device boxes.
- D. GFI receptacles shall be provided with separate insulated ground wire conductor to the main service or distribution panelboard ground bar.
- E. Ground all motor and equipment connections with dedicated ground conductor.

2.06 IDENTIFICATION

- A. Junction and pull boxes shall be stenciled utilizing a coded identification system. The following junction and pull boxes shall be identified using a coded system. Coding shall be submitted to Engineer for approval.

1. Light and Power - 120/208V.
- B. Label circuit numbers for all accessible line voltage power distribution raceways and junction boxes.
- C. Laminated Bakelite Plates: Engraved plastic nameplate shall be securely fastened to the following equipment. Size 1" x 4" with 3/8" high letters unless space available dictates differently.
 1. Each section of main distribution switchboards and panelboards. Mount one next to each protection device to identify load served by each circuit breaker.
- D. Typewritten Directory: Each panelboard shall be provided with a typewritten directory in a steel frame with plastic cover contained on the inside of panel door. These directories shall indicate load served and rooms served by each protective device in the respective panel.
- E. Identify all conductors per NEC:
120/208V 3-phase 4-wire:
 - Phase A - Black
 - Phase B - Red
 - Phase C - Blue
 - Neutral - White
 - Ground - Green
- F. Label all receptacle plates with self-adhesive clear labeling tape and black letters indicating panel # and circuit # serving device.

2.07 WIRING DEVICES

A. General:

1. Devices shall be provided at each location shown on the plans or called for in the Specifications.
2. All devices shall be of one manufacturer. Acceptable manufacturers: Leviton, Pass and Seymour or Hubbell.
3. Device catalog references herein and on the plans are to be considered as standards of comparison. Comparable devices manufactured by the other manufacturer will be considered as an optional choice.

B. Receptacles:

2. Duplex Receptacles: Industrial-specification grade, nylon face and base, ivory color, side-wired only, 3-wire grounding type with the third terminal U-shaped and grounded to the conduit system or green wire ground. Use of self-grounding option not permitted.
3. NEMA 5-15R, 15A - Leviton 5262A.
4. NEMA 5-20R, 20A - Leviton 5362A.
5. NEMA 5-15R, 15A GFCI Receptacle: Specification grade with lock-out action, indicator light and feed through. Equal to Leviton 8598-HG.

C. Switches:

1. All toggle switches used to control lighting shall be 20 amp rated for 120/277 volts, A.C., industrial-specification grade ivory color.
2. 15 amp switches shall not be used unless specifically shown otherwise for special control.

3. Switches to be back and side wired, silent or quiet type.
4. The following catalog numbers refer to Leviton, Inc.:
 - a. single pole – 1221-2I
 - b. three way – 1223-2
 - c. four way – 1224-2
 - d. Single pole with pilot light – 1221-PLR (red)

D. Plates:

1. Provide as required for each outlet, single or multiple gang.
2. Provide blank covers on all empty boxes or outlets.
3. Plates shall be 204 stainless steel or nylon construction in all finished areas; confirm Owner's preference prior to ordering.
4. Galvanized steel box covers shall be used in unfinished areas. Cover shall be 1/2" raised with no sharp edges.
5. Provide single-gang die-cast or impact resistant thermoplastic covers and gasketed bases NEMA-3R rated "while-in-use" equal to Leviton 5976-GY(vertical) or 5996-GY(horizontal) on receptacles in damp or exterior locations.

2.08 RACEWAY SYSTEM

A. Steel Conduit: Galvanized or sheradized steel intermediate(IMC) or rigid metal conduit(RMC), or electrical metallic tubing (EMT) with steel compression ring or steel set screw type fittings.

1. Provide steel conduits concealed in the walls, above the ceilings, or exposed in the work areas.
2. Indented or cast fittings are not acceptable.
3. Where conduit is installed underground or in the floor slab, provide rigid galvanized steel(RMC) conduit with PVC interior coating or PVC coated steel conduit.
4. Provide liquid-tight rigid metal conduit(RMC) or Intermediate metal conduit(IMC) at exterior locations above grade.

B. Rigid Non-Metallic Conduit: Schedule 80 PVC with solvent welded fittings.

1. Below grade installation only.
2. Encase in concrete below drives and roadways.
3. ENT flexible non-metallic conduit may be used in concealed masonry areas above grade.

C. Outlets, Junction Boxes and Switch Boxes:

1. Provide standard one-piece units, galvanized or sheradized, of shape and size best suited to that particular location, of sufficient size to contain enclosed wires without crowding.
2. Provide deep boxes with 1" and larger conduit.
3. For lighting outlets, provide standard 4" octagon or square units, with 3/8" malleable iron fixture studs and box hangers where required.
4. For switches and receptacles, provide boxes 4" square by 1-1/2" deep minimum with rings and covers as required.
5. Provide cast liquid-tight boxes with gaskets at exterior locations.

D. For pull boxes, provide galvanized code-gauge sheet units with screw-on covers, of size and shape required to accommodate wires without crowding and to suit the location.

D. Provide sleeves and chases where conduits pass through floors and walls.

2.09 CONDUCTORS

- A. Wire and Cable (600 Volt): Provide 600 V insulated copper wire and cable, NEC standard, of types specified below for different applications, with UL label, and color coded as required by governmental agencies having jurisdiction. Use only copper wires and cables.
1. With conductors No. 4 and larger, provide insulating bushings.
 2. Interior wire and cable shall be THHN or THWN.
 3. Exterior wire and cable shall be XHHW-2.
 4. Wire No. 10 and smaller shall be solid or stranded wire; wire larger than No. 10 shall be stranded wire.
 5. Wire in conduits subjected to direct sunlight shall be THWN or XHWN.
 6. Identify feeder neutrals with white tape or white paint.
- B. Armored Cable (AC) or Metal-Clad Cable (MC):
1. Limit AC and MC usage to concealed only locations, branch-circuit wiring after the first junction box from the panelboards; where approved by NEC, state and local electrical inspecting authorities.
 2. Not allowed for Panelboard feeders or service conduit.
 3. Provide and install per NEC Articles 333 and 334 with grounding conductor.
- C. Below grade conductor splices:
1. Compression type inline splice connectors, watertight assembly, dual rated AL9CU for stranded copper or aluminum conductors.
 2. UL 486B listed.
 3. Burndy "UNITAP" BISR, BIBD or BISR series or approved equal.

2.10 MOTOR WIRING

- A. See plans for approximate location and sizes of all motors. Verify exact locations at job site with the contractor that is furnishing the motor driven equipment.
- B. The Drawing motor schedules indicate that the anticipated horsepower loads and circuit sizes. Verify all these requirements with contractor concerned and install accordingly under this contract.
- C. Install disconnect means where required by code for motors out of sight of controller. These shall be fusible safety switches, fusetron box cover unit, or non-fused switch as indicated on plans. All switches shall be horsepower rated.
- D. All motors will be furnished and installed by others, unless noted otherwise.
- E. Motor starters to be provided and installed by the Electrical Contractor unless indicated otherwise herein or on the plans. See Motor Schedule.
- F. All final connections to motors to be made by this Contractor.
- G. All motors to be connected using flexible metallic conduits extending from motor box to outlet box. Use liquid tight flexible metallic conduit with PVC covering in wet or oily locations and for all motors within 12" of floor. See paragraph on GROUNDING. All wires in flexible metallic conduit shall be stranded. Grounding wires shall be in all cases installed in flexible conduit and not wrapped around the outside of the conduit.

2.11 MOTOR STARTERS

A. General:

1. Indoor - NEMA Type 1.
2. Outdoors or where exposed to moisture - NEMA Type 3R, raintight.
3. Units shall open all ungrounded conductors simultaneously.
4. All starters shall be from a single manufacturer.
5. Approved Manufacturers: Square D.

B. Manual Starters:

1. For single-phase starters, provide units of tumbler switch type that clearly indicate ON, OFF and TRIPPED positions.
2. For three-phase starters, provide pushbutton operated units with START, STOP-RESET button on the enclosure cover.

C. Magnetic Starters:

1. Provide units with operating coils designed to operate on line voltage or any other auxiliary voltage indicated on the Drawings.
2. For starters with line voltage operating coils, provide built-in under-voltage release.
3. Provide units with the accessories and auxiliary contacts needed for automatic or remote operation as shown on the Drawings.
4. Provide "H-O-A" control switch and "green" run light on unit cover.
5. Provide thermal overload protection in each phase which if any phase trips causes the starter to drop out.

2.12 SAFETY SWITCHES

A. Provide safety switches of heavy duty type, horsepower rated, quick-make and quick-break design, externally operated with provision for padlocking, fusible or non-fusible as shown on the Drawings.

B. Provide enclosures clearly marked for maximum voltage, current, and horsepower rating, and:

1. Indoor: NEMA type 1.
2. Outdoor: NEMA type 3R, raintight.

C. Approved Manufacturers: Square D.

2.13 LIGHTING FIXTURES

A. Provide fixtures of the types shown on the Drawings, and with the following accessories as applicable.

B. Light Fixtures:

1. Provide units having a UL label.
2. Provide local label in addition if so required by governmental agencies having jurisdiction.
3. Verify all ceiling types as shown on final architectural plans and be responsible for ordering proper fixtures and accessories for the proper ceiling.

C. LED Lighting:

1. The manufacturer of the LED lighting fixture shall utilize high-brightness LEDs and high-efficiency electronic LED drivers, dimmed or no dimmed as required.
2. The LED fixture shall be thermally designed as to not exceed the maximum junction temperature of the LED for the ambient temperature of the location the fixture is to be installed.
3. Light output of the LED system shall be the absolute photometry following IESNA LM-79 and IESNA LM-80 requirements and guidelines.
4. Minimum power factor of 0.90.
5. LED lighting fixture shall be mercury-free, lead-free and RoHS compliant.
6. The LED lighting fixture shall maintain 70% lumen output for a minimum of 50,000 hours.
7. All components of the LED lighting fixture shall be replaceable.
8. The LED lighting fixture shall carry a limited 3-year warranty minimum.

D. Acceptable Lighting Fixture Manufacturers:

1. Refer to **Fixture Schedule**. Engineer will evaluate and make final decision on whether submitted fixture is equal to specified light fixture.

2.14 OTHER MATERIALS

- A. Provide other materials, not specifically described but required for a complete and proper installation, as selected by the Contractor subject to the approval of the Architect.

PART 3 - EXECUTION

3.01 SURFACE CONDITIONS

- A. Examine the areas and conditions under which work of this Section will be performed. Correct conditions detrimental to timely and proper completion of the Work. Do not proceed until unsatisfactory conditions are corrected.

3.02 PREPARATION

A. Coordination:

1. Coordinate as necessary with other trades to assure proper and adequate provision in the work of those trades for interface with the work of this Section.
 2. Coordinate the installation of electrical items with the schedule for work of other trades to prevent unnecessary delays in the total Work.
 3. Where lighting fixtures and other electrical items are shown in conflict with locations of structural members and mechanical or other equipment, provide required supports and wiring to clear the encroachment.
- B. Data indicated on the Drawings and in these Specifications are as exact as could be secured, but their absolute accuracy is not warranted. The exact locations, distances, levels, and other conditions will be governed by actual construction and the Drawings and Specifications should be used only for guidance in such regard.
- C. Where outlets are not specifically located on the Drawings, locate as determined in the field by the Architect. Where outlets are installed without such specific direction, relocate as directed by the Architect and at no additional cost to the Owner.

- D. Verify all measurements at the building. No extra compensation will be allowed because of differences between work shown on the drawings and actual measurements at the site of construction.
- E. The Electrical Drawings are diagrammatic, but are required to be followed closely as actual construction and work of other trades will permit. Where deviations are required to conform with actual construction and the work of other trades, make such deviations without additional cost to the Owner.

3.03 TRENCHING AND BACKFILLING

- A. Perform trenching and backfilling associated with the work of this Section in strict accordance with the provisions of Division 31 of these Specifications.
- B. Cut bottom of trench to grade, make trench 12” wider than the widest dimension of the pipe.
- C. Bedding:
 - 1. Do not start backfill operations until underground plumbing work has been properly inspected and approved by governing authorities.
 - 2. Provide four (4) inches of bedding and six (6) inches of cover over all underground conduits.
- D. Backfilling:
 - 1. Disturbed areas outside of structure shall be returned to existing grade with six (6) inches of topsoil.
 - 2. Compaction of backfill material outside the structure and structure’s ZOI shall meet 90% Modified Proctor, the standard specification of ASTM D-1557.
 - 3. Compaction of Low Frost Susceptibility Granular Fill within the structure and structures ZOI shall meet 95% Modified Proctor, the standard specification or ASTM D-1557.

3.04 INSTALLATION OF RACEWAYS AND FITTINGS

- A. Where conduit is installed concealed in walls or above ceiling, or exposed in work areas, provide rigid galvanized conduit or electrical metallic tubing with compression type fittings.
 - 1. Seal joints to prevent entrance of water.
 - 2. Provide ground wire of proper size per NEC 250.
 - 3. Use nylon (rather than steel) fish tape.
- B. Use flexible conduit only for short motor connections, or where subject to vibration.
- C. Provide necessary sleeves and chases where conduits pass through floors and walls and provide other necessary openings and spaces, arranging for proper time to prevent unnecessary cutting in connection with the Work.
- D. Where conduit is exposed, run parallel to or at right angle with lines of the building.
- E. Securely and rigidly support conduits throughout the work.

3.05 INSTALLATION OF CONDUIT

- A. Provide for the proper application, installation and location of inserts, supports and anchor bolts, for a satisfactory raceway system. Replace any damaged components of the raceway system.
- B. Run conduits concealed. Conduits may be exposed only when it is impossible or impractical to conceal. Mechanical rooms may use exposed conduit.
- C. All conduits that protrude through slabs shall be PVC coated rigid conduit.
- D. Conduit seals shall be provided where conduits pass from interior walls to exterior walls in accordance with NEC.
- E. All conduits installed below grade shall be buried a minimum of 2 feet.

3.06 INSTALLATION OF OUTLETS, LIGHT SWITCHES, AND PULL AND JUNCTION BOXES

- A. Outlets and light switch timers shall be installed at the locations and heights indicated on the Drawings.
- B. Pull and junction boxes shall be located in accessible locations as approved by Engineer.
- C. Outlets, light switches, and pull and junction boxes shall be supported independently from conduit.
- D. All outlets, light switches, and pull and junction boxes shall be recessed; secure boxes to walls to provide for flush cover finish.

3.07 INSTALLATION OF LIGHTING FIXTURES

- A. Install lighting fixtures complete and ready for service in accordance with the Lighting Fixture Schedule shown on the Drawings.
- B. Wire fixtures with fixture wiring of at least 90 degrees C rating. Where fixtures are mounted in continuous rows, provide conductors in wiring channels of the same size as the circuit wires supplying the row of fixtures.
- C. Use only bonderized, galvanized, or sheradized steel for fixture installation for protection against rust and corrosion, and install fluorescent fixtures straight and true with reference to walls.
- D. Install all lighting fixtures, including those mounted in continuous rows, so that the weight of the fixture is supported, either directly or indirectly, by a safe and sound structural member of the building, using adequate number and type of fastenings to assure safe installation.
 - 1. Screwed fastenings, and toggle bolts through ceiling material or wall paneling, are not acceptable.
 - 2. Install T-bar hold-down clips on all light fixtures.

3.08 INSTALLATION OF POWER EQUIPMENT

- A. Provide power and control wiring for motor starters and safety switches as shown on the Drawings.

3.09 INSTALLATION OF CONDUCTORS

- A. Unless otherwise shown on the Drawings or noted in these Specifications, use No. 12 AWG conductors for all branch circuits, protected by 20 amp circuit breakers. For runs exceeding 100 feet, use larger wires to limit voltage drops.
- B. Use identified (white) neutrals and color-coded phase wires for all branch circuit wiring.
 - 1. Make splices electrically and mechanically secure with pressure-type connectors.
 - 2. Provide "Scotchlok", Buchanon "B-cap", or Ideal "Wing-nut" connectors for wires sizes 6 AWG and smaller.
 - 3. Provide Burndy compression-type connectors, "Hydent" or equal applied with a mechanical tool and die equipment for wire sizes 4 AWG and larger,.
 - 4. Insulate splices with a minimum of two half-lapped layers of Scotch Branch No. 33 vinyl-plastic electrical tape where insulation is required.

3.10 TESTING AND INSPECTION

- A. Provide personnel and equipment, make required tests, and secure required approvals from the Architect and governmental agencies having jurisdiction.
- B. Make written notice to the Architect adequately in advance of each of the following stages of construction:
 - 1. Test all parts of the electrical system and prove that all such items provided under this Section function electrically in the required manner.
 - 2. Immediately submit to the Architect a report of maximum and minimum voltages and a copy of the recording volt-meter chart.
 - 3. Also measure voltages between phases and between phase wires and neutrals and report these voltages to the Architect.

3.11 PROJECT COMPLETION

- A. Upon completion of the work of this Section, thoroughly clean all exposed portions of the electrical installation, removing all traces of soil, labels, grease, oil, and other foreign material, and using only the type cleaner recommended by the manufacturer of the item being cleaned.
- B. Thoroughly indoctrinate the Owner's operation and maintenance personnel in the contents of the operations and maintenance manual required to be submitted under Article 1.3 of this Section of these Specifications.

END OF SECTION

Page Intentionally Left Blank

SECTION 31 20 00

EARTH MOVING

PART 1 - GENERAL

1.1 SUMMARY

- A. This Section includes the following:
 - 1. Excavating and backfilling for buildings and structures.
 - 2. Drainage course for slabs-on-grade.

1.2 DEFINITIONS

- A. Backfill: Soil material, or controlled low-strength material, used to fill an excavation.
 - 1. Initial Backfill: Backfill placed beside and over pipe in a trench, including haunches to support sides of pipe.
 - 2. Final Backfill: Backfill placed over initial backfill to fill a trench.
- B. Borrow Soil: Satisfactory soil imported from off-site for use as fill or backfill.
- C. Drainage Course: Course supporting the slab-on-grade that also minimizes upward capillary flow of pore water.
- D. Excavation: Removal of material encountered above subgrade elevations and to lines and dimensions indicated.
 - 1. Unauthorized Excavation: Excavation below subgrade elevations or beyond indicated lines and dimensions without direction by Architect. Unauthorized excavation, as well as remedial work directed by Architect, shall be without additional compensation.
- E. Fill: Soil materials used to raise existing grades.
- F. Structures: Buildings, footings, foundations, retaining walls, slabs, tanks, curbs, mechanical and electrical appurtenances, or other man-made stationary features constructed above or below the ground surface.
- G. Subgrade: Surface or elevation remaining after completing excavation, or top surface of a fill or backfill immediately below subbase, drainage fill, or topsoil materials.

1.3 PROJECT CONDITIONS

- A. Existing Utilities: Do not interrupt utilities serving facilities occupied by Owner or others unless permitted in writing by Architect and then only after arranging to provide temporary utility services according to requirements indicated.

1.4 SUBMITTALS

- A. Material Test Reports: From a qualified testing agency indicating and interpreting test results for compliance of the following with requirement indicated:
 - 1. Classification according to ASTM D 2487 of each borrow soil material proposed for fill and backfill.
 - 2. Laboratory compaction curve according to ASTM D 1557 for each on-site borrow soil material proposed for fill and backfill.
- B. Testing: Contractor shall arrange and pay for compaction testing in all footing locations; minimum 95 percent modified proctor density.
- C. Pre-excavation Photographs or Videotape: Show existing conditions of adjoining construction and site improvements, including finish surfaces that might be misconstrued as damage caused by earthwork operations. Submit before earthwork begins.

1.5 QUALITY ASSURANCE

- A. Pre-excavation Conference: Conduct conference at Project site.

PART 2 - PRODUCTS

2.1 SOIL MATERIALS

- A. General: Provide borrow soil materials when sufficient satisfactory soil materials are not available from excavations.
- B. Satisfactory Soils: ASTM D 2487 Soil Classification Groups GW, GP, GM, SW, SP, and SM, or a combination of these groups; free of rock or gravel larger than 3 inches in any dimension, debris, waste, frozen materials, vegetation, and other deleterious matter.
- C. Unsatisfactory Soils: Soil Classification Groups GC, SC, CL, ML, OL, CH, MH, OH, and PT according to ASTM D 2487, or a combination of these groups.
 - 1. Unsatisfactory soils also include satisfactory soils not maintained within 2 percent of optimum moisture content at time of compaction.
- D. Subbase Material: Naturally or artificially graded mixture of natural or crushed gravel, crushed stone, and natural or crushed sand; ASTM D 2940; with at least 90 percent passing a 1-1/2-inch sieve and not more than 12 percent passing a No. 200 sieve.
- E. Base Course: Naturally or artificially graded mixture of natural or crushed gravel, crushed stone, and natural or crushed sand; ASTM D 2940; with at least 95 percent passing a 1-1/2-inch sieve and not more than 8 percent passing a No. 200 sieve.
- F. Engineered Fill: Naturally or artificially graded mixture of natural or crushed gravel, crushed stone, and natural or crushed sand; ASTM D 2940; with at least 90 percent passing a 1-1/2-inch sieve and not more than 12 percent passing a No. 200 sieve.

2.2 ACCESSORIES

- A. Warning Tape: Acid- and alkali-resistant polyethylene film warning tape manufactured for marking and identifying underground utilities, a minimum of 6 inches wide and 4 mils thick, continuously inscribed with a description of the utility, with metallic core encased in a protective jacket for corrosion protection, detectable by metal detector when tape is buried up to 30 inches deep; colored as follows:
1. Red: Electric.
 2. Yellow: Gas, oil, steam, and dangerous materials.
 3. Orange: Telephone and other communications.
 4. Blue: Water systems.
 5. Green: Sewer systems.

PART 3 - EXECUTION

3.1 PREPARATION

- A. Protect structures, utilities, sidewalks, pavements, and other facilities from damage caused by settlement, lateral movement, undermining, washout, and other hazards created by earthwork operations.
- B. Erosion Control: Provide and maintain as required by municipality but not less than 3 inch clear stone tracking pad, silt fencing, runoff and sediment control, and netting or similar erosion-control devices within the storm water detention pond.
- C. Topsoil Stripping:
1. Remove sod, grass, plants and brush before stripping topsoil.
 2. Strip topsoil and stockpile onsite for reuse.

3.2 EXPLOSIVES

- A. Explosives: Do not use explosives.

3.3 EXCAVATION

- A. Unclassified Excavation: Excavate to subgrade elevations regardless of the character of surface and subsurface conditions encountered. Unclassified excavated materials may include rock, soil materials, and obstructions. No changes in the Contract Sum or the Contract Time will be authorized for rock excavation or removal of obstructions.
1. If excavated materials intended for fill and backfill include unsatisfactory soil materials and rock, replace with satisfactory soil materials.
 2. Remove rock to lines and grades indicated to permit installation of permanent construction without exceeding the following dimensions:

- a. 24 inches outside of concrete forms other than at footprints.
- b. 12 inches outside of concrete forms at footings.
- c. 6 inches outside of minimum required dimensions of concrete cast against grade.
- d. Outside dimensions of concrete walls indicated to be cast against rock without forms or exterior waterproofing treatments.
- e. 6 inches beneath bottom of concrete slabs on grade.

3.4 EXCAVATION FOR STRUCTURES

- A. Excavate to indicated elevations and dimensions within a tolerance of plus or minus 1 inch. If applicable, extend excavations a sufficient distance from structures for placing and removing concrete formwork, for installing services and other construction, and for inspections.
 1. Excavations for Footings and Foundations: Do not disturb bottom of excavation. Excavate by hand to final grade just before placing concrete reinforcement. Trim bottoms to required lines and grades to leave solid base to receive other work.

3.7 SUBGRADE INSPECTION

- A. Notify A/E when excavations have reached required subgrade.
- B. If A/E determines that unsatisfactory soil is present, continue excavation and replace with compacted backfill or fill materials as directed.
- C. After existing fill and pavement are removed, compact subgrade to required density. Avoid the use of large vibratory compactors to prevent damage to adjacent structures.
- D. Reconstruct subgrades damaged by rain, accumulated water, or construction activities without additional compensation.

3.8 UNAUTHORIZED EXCAVATION

- A. Fill unauthorized excavation under foundations or wall footings by extending bottom elevation of concrete foundation or footing to excavation bottom, without altering top elevation. Lean concrete fill, with 28-day compressive strength of 2500 psi, may be used.
 1. Fill unauthorized excavations under other construction or utility pipe as directed by Architect.

3.9 STORAGE OF SOIL MATERIALS

- A. Stockpile borrow soil materials and excavated satisfactory soil materials without intermixing. Place, grade, and shape stockpiles to drain surface water. Cover to prevent windblown dust.
 1. Stockpile soil materials away from edge of excavations. Do not store within drip line of remaining trees.

3.10 BACKFILL

- A. Place and compact backfill in excavations promptly, but not before completing the following:
 - 1. Construction below finish grade including, where applicable, subdrainage, dampproofing, waterproofing, and perimeter insulation.
 - 2. Surveying locations of underground utilities for Records Department.
 - 3. Testing and inspecting of underground utilities.
 - 4. Removing concrete formwork.
 - 5. Removing trash and debris.
 - 6. Removing temporary shoring and bracing, and sheeting.
 - 7. Installing permanent or temporary horizontal bracing on horizontally supported walls.
- B. Place backfill on subgrades free of mud.

3.12 SOIL FILL

- A. Plow, scarify, bench, or break up sloped surfaces steeper than 1 vertical to 4 horizontal so fill material will bond with existing material.
- B. Place and compact fill material in layers to required elevations as follows:
 - 2. Under grass and planted areas, use satisfactory soil material.
 - 3. Under walks and pavements, use satisfactory soil material.
 - 4. Under steps and ramps, use engineered fill.
 - 5. Under building slabs, use engineered fill.
 - 6. Under footings and foundations, use engineered fill.

3.13 SOIL MOISTURE CONTROL

- A. Uniformly moisten or aerate subgrade and each subsequent fill or backfill soil layer before compaction to within 2 percent of optimum moisture content.
 - 1. Remove and replace, or scarify and air dry otherwise satisfactory soil material that exceeds optimum moisture content by 2 percent and is too wet to compact to specified dry unit weight.

3.14 COMPACTION OF SOIL BACKFILLS AND FILLS

- A. Place backfill and fill soil materials in layers not more than 8 inches in loose depth for material compacted by heavy compaction equipment, and not more than 4 inches in loose depth for material compacted by hand-operated tampers.

- B. Place backfill and fill soil materials evenly on all sides of structures to required elevations, and uniformly along the full length of each structure.
- C. Compact soil materials to not less than the following percentages of maximum dry unit weight according to ASTM D 1557:
 - 1. Under structures and building slabs scarify and re-compact top 12 inches of existing subgrade and each layer of backfill or fill soil material at 95 percent.

3.16 DRAINAGE COURSE

- A. On prepared subgrade, place and compact drainage course under cast-in-place concrete slabs-on-grade as follows:
 - 1. Place drainage course 6 inches or less in compacted thickness in a single layer.
 - 2. Place drainage course that exceeds 6 inches in compacted thickness in layers of equal thickness, with no compacted layer more than 6 inches thick or less than 3 inches thick.
 - 3. Compact each layer of drainage course to required cross sections and thicknesses to not less than 95 percent of maximum dry unit weight according to ASTM D 698.

3.17 FIELD QUALITY CONTROL

- A. Testing Agency: Owner will engage a qualified independent geotechnical engineering testing agency to perform field quality-control testing.
- B. Allow testing agency to inspect and test subgrades and each fill or backfill layer. Proceed with subsequent earthwork only after test results for previously completed work comply with requirements.
- C. Footing Subgrade: At footing subgrades, at least one test of each soil stratum will be performed to verify design bearing capacities. Subsequent verification and approval of other footing subgrades may be based on a visual comparison of subgrade with tested subgrade when approved by Architect.
- D. Testing agency will test compaction of soils in place according to ASTM D 1556, ASTM D 2167, ASTM D 2922, and ASTM D 2937, as applicable.
- E. When testing agency reports that subgrades, fills, or backfills have not achieved degree of compaction specified, scarify and moisten or aerate, or remove and replace soil to depth required; re-compact and retest until specified compaction is obtained.

3.18 PROTECTION

- A. Protecting Graded Areas: Protect newly graded areas from traffic and erosion. Keep free of trash and debris.
- B. Repair and reestablish grades to specified tolerances where completed or partially completed surfaces become eroded, rutted, settled, or where they lose compaction due to subsequent construction operations or weather conditions.

- C. Where settling occurs before Project correction period elapses, remove finished surfacing, backfill with additional soil material, compact, and reconstruct surfacing.
 - 1. Restore appearance, quality, and condition of finished surfacing to match adjacent work, and eliminate evidence of restoration to greatest extent possible.

3.19 DISPOSAL OF SURPLUS AND WASTE MATERIALS

- A. Disposal: Remove surplus satisfactory soil and waste material, including unsatisfactory soil, trash, and debris, and legally dispose of it off Owner's property.

END OF SECTION 31 20 00

Page Intentionally Left Blank

SECTION 32 31 19

DECORATIVE METAL FENCES AND GATES

PART 1 GENERAL

1.1 SECTION INCLUDES

- A. Commercial steel ornamental fence system - fusion welded.

1.2 RELATED SECTIONS

- A. Section 03 30 00 - Cast-in-Place Concrete.

1.3 REFERENCES

- 1..
 - 2. ASTM D 2244 - Test Method for Calculations of Color Differences from Instrumentally Measured Color Coordinates.
 - 3. ASTM D 2794 - Test Method for Resistance of Organic Coatings to the Effects of Rapid Deformation (Impact). ASTM D3359 - Test Method for Measuring Adhesion by Tape Test.
 - 4. ASTM D 3359 - Test Method for Measuring Adhesion by Tape Test.
- B. AAMA - American Architectural Manufacturers Association:
 - 1. AAMA 2603 - Voluntary Specification, Performance Requirements and Test Procedures for Pigmented Organic Coatings on Aluminum Extrusions and Panels.

1.4 SUBMITTALS

- A. Manufacturer's data sheets on each product to be used, including:
 - 1. Preparation instructions and recommendations.
 - 2. Storage and handling requirements and recommendations.
 - 3. Installation methods.
- B. Shop Drawings: Indicate plan layout, spacing of components, post foundation dimensions, hardware anchorage, gates, and schedule of components.
- C. Selection Samples: For each finish product specified, two complete sets of color chips representing manufacturer's full range of available colors and patterns.
- D. Verification Samples: For each finish product specified, two samples, minimum size 6 inches (150 mm) square, representing actual product, color, and patterns.

1.5 QUALITY ASSURANCE

- A. Manufacturer Qualifications: Company specializing in manufacturing Products specified in this section with minimum five years documented experience.

- B. Installer Qualifications: Installers experienced with type of construction involved and materials and techniques specified.
- C. Single Source: Entire fence system, and all associated accessories, fittings, and fasteners shall be obtained from a single source.

1.6 DELIVERY, STORAGE, AND HANDLING

- A. Upon receipt at the job site, all materials shall be checked to ensure that no damage occurred during shipping or handling.
- B. Materials shall be stored in such a manner to ensure proper ventilation and drainage, and be protected against damage, weather, vandalism, and theft.

1.7 PROJECT CONDITIONS

- A. Maintain environmental conditions (temperature, humidity, and ventilation) within limits recommended by manufacturer for optimum results. Do not install products under environmental conditions outside manufacturer's absolute limits.

1.8 WARRANTY

- A. The powder coated surface on all components (pickets, rails, and posts) is warranted for 10 years. Refer to manufacturer for complete details regarding warranty.

PART 2 PRODUCTS

2.1 MANUFACTURERS

- A. Acceptable Manufacturer: Basis of Design: Ameristar Fence Products. Or Approved Equal

2.2 ORNAMENTAL FENCING

- A. Commercial Steel Ornamental Fence System - Fusion Welded: System includes posts, panels, and mounting accessories.
 - 1. Acceptable Product: Montage Plus or Montage Commercial.
 - 2. Grade: Commercial.
 - 3. Standard Style: 3 rail, in 6' long panel sections.
 - 1) Three Rail: Style Classic.
 - 4. Height:
 - a. Height: 8 feet.
 - 5. Steel (ASTM A924/A924M): Steel for tubular pickets, rails and posts shall have minimum yield strength of 45,000 psi (310 MPa).
 - 6. Galvanizing (ASTM A653/A653M): Prior to forming, hot dip galvanized with minimum zinc coating weight of 0.60 oz/ft² (184 g/m²), Coating Designation G-60.
 - 7. Rails:
 - a. Standard Picket Spacing: 3" o.c.
 - b. Top and Bottom Rail 3" X 3"

- c. Intermediate rail 14" from top 2" X 2"
- 8. Pickets: 3/4 inches square x 14 gauge tubing
- 9. Racking/Biasability (Ability of Panels to Follow Grades): able to follow varying grade changes to a maximum of 48 inch run.
- 10. Posts:
 - a. Size: 3 inches by 3 inches by 12 gauge w/ standard post cap.
- 11. Accessories: Aluminum castings and steel anchor plates
 - a. Caps from manufacturers range of post caps.
 - b. 1 / 4" thick HD galvanized bent plate over concrete parapet walls at each post shoe, with galv. Anchors suitable for attachment to concrete parapets or retaining wall.
- 12. Steel (ASTM A924/A924M): Steel for tubular pickets, rails and posts shall have minimum yield strength of 45,000 psi (310 MPa).
 - a. Galvanizing (ASTM A653/A653M): Prior to forming, hot dip galvanized with minimum zinc coating weight of 0.90 oz/sq ft Coating Designation G-90.
- 13. Rails:
 - a. Acceptable Product: Ameristar Rails.
 - b. Double-walled U channel; outside cross-section dimensions of 3 inch square; minimum thickness of 14 gauge; inside galvanized; open ends for air circulation and moisture evaporation.
 - c. Panel Length: 6 foot typical.
 - d. Rail Strength:
 - 1) Effective Wall Thickness: 0.160 inch.
 - 2) Rail Weight: 2.13 lbs/ft.
 - e. Enclosed Retaining Rod: Retaining rods shall be 0.125 inch (3.2 mm) diameter galvanized steel. Variable pitch connection system for, high angle racking and elimination of external fasteners
 - f. PVC Grommets: Provide grommets to seal all picket-to-rail intersections.
- 14. Fasteners: All fasteners shall be 302 stainless steel; match finish of fence.
 - a. Security Fastener: one-way tamperproof security bolts with inverted t-nuts.
 - b. Bracket to Post Connections: Self-drilling hex-head screws.
- 15. Panels: Completed panels shall be capable of supporting a 400 pound load applied at midspan without permanent deformation.
- 16. Racking/Biasability (Ability of Panels to Follow Grades): Minimum of 25 percent slope.

2.3 FINISH

- A. PermaCoat: Thermal stratification coating process (high-temperature, in-line, multi-stage, multi-layer) including six-stage pretreatment/wash with zinc phosphate, an electrostatic spray application of epoxy base, and a separate electrostatic spray application of a polyester top coat finish.
 - 1. Base Coat Coating Thickness: Thermosetting epoxy powder coating with minimum thickness of 2 to 4 mils (0.0508 to 0.1016 mm).
 - 2. Top Coat Coating Thickness: No-mar TGIC polyester powder finish with minimum thickness of 2 to 4 mils. Black.

3. Coating Performance Requirements: Coating meets or exceeds the following.
 - a. Adhesion (ASTM D 3359, Method B): Adhesion over 90 percent of test area (tape and knife test).
 - b. Corrosion Resistance (ASTM B 117, ASTM D 1654): Coated galvanized steel shall be capable of salt spray resistance for 3,500 hours without loss of adhesion on parts scribed per ASTM D1654 and tested in accordance with ASTM Test Method B117. Failure is considered to have occurred when there is either 1/8 inch (3.18 mm) coating loss from the scribed mark or an accumulation of medium #8 blisters.
 - c. Impact Resistance (ASTM D 2794): 60 inch pounds, minimum (impact using 0.625 inch ball).
 - d. Weathering Resistance (ASTM D 822, D 2244, D 523 - 60 Degree Method): 1,000 hours, minimum (failure mode is 60 percent loss of gloss or color variance of more than 3 delta-E color units.)

2.4 FABRICATION

- A. ProFusion Welding System:
 1. Rails shall be pre-punched to accept pickets.
 2. Pickets shall be inserted into the pre-punched holes in the rails and shall be aligned to standard spacing using a specially calibrated alignment fixture.
 3. The aligned pickets and rails shall be joined at each picket-to-rail intersection by Ameristar's proprietary fusion welding process, (ProFusion Welding) thus completing the rigid panel assembly.

PART 3 EXECUTION

3.1 EXAMINATION

- A. Do not begin installation until substrates have been properly prepared.
- B. If substrate preparation is the responsibility of another installer, notify Architect of unsatisfactory preparation before proceeding.

3.2 PREPARATION

- A. Clean surfaces thoroughly prior to installation.
- B. Prepare the grade and remove surface irregularities, if any, which may cause interference with the installation of fencing.
- C. If preparation and condition is the responsibility of another installer, notify Architect of unsatisfactory preparation before proceeding.

3.3 INSTALLATION

- A. Install in accordance with manufacturer's instructions.
- B. Fence posts shall be set in accordance with the manufacturer recommended spacing.
- C. Panels shall be attached to posts using mechanically fastened panel brackets supplied by the manufacturer. Connect to 1/4" galv. Steel base plate suitable for connection to concrete retaining wall or concrete parapet.

- D. Impasse panels shall be attached to posts using mounting brackets and tamperproof security fasteners supplied by the manufacturer.
- E. When cutting rails immediately seal the exposed surfaces by:
 - 1. Removing all metal shavings from cut area.
 - 2. Apply zinc-rich primer to thoroughly cover cut edge and drilled hole; allow to dry.
 - 3. Apply 2 coats of custom finish spray paint matching fence color.
 - 4. Failure to seal exposed surfaces in accordance with manufacturer's instructions will negate manufacturer's warranty.
- F. Gate posts shall be spaced according to the manufacturers' gate drawings, dependent on standard out-to-out gate leaf dimensions and gate hardware selected.
 - 1. Type and quantity of gate hinges shall be based on the application; weight, height, and number of gate cycles.
 - 2. The manufacturer's gate drawings shall identify the necessary gate hardware required for the application.
 - 3. Gate hardware shall be provided by the manufacture of the gate and shall be installed per manufacturer's recommendations

3.4 ERECTION TOLERANCES

- A. Maximum Variation From Plumb: 1/4 inch.
- B. Maximum Offset From Indicated Position: 1 inch.
- C. Minimum distance from property line: 6 inches.

3.5 CLEANING

- A. Leave immediate work area neat at end of each work day.
- B. Clean jobsite of excess materials; scatter excess material from post-hole excavations uniformly away from posts. Remove excess material if required.
- C. Clean fence with mild household detergent and clean water rinse well. Mortar should be removed from exposed posts and other fencing material using a 10% solution of muriatic acid followed immediately by several rinses with clean water.
- D. Touch up scratched surfaces using materials recommended by manufacturer. Match touchup paint color to fence finish.

3.6 PROTECTION

- A. Protect installed products until completion of project.
- B. Touch-up, repair or replace damaged products before Substantial Completion.

END OF SECTION 32 31 19

Page Intentionally Left Blank

DIMENSION IV

Madison Design Group
architecture · engineering · interior design

6515 Grand Teton Plaza, Suite 120, Madison, Wisconsin 53719
p608.829.4444 f608.829.4445 dimensionivmadison.com

PROJECT REQUEST FOR BID # 316001

COLISEUM LOADING DOCKS - ALLIANT ENERGY CENTER

1919 Alliant Energy Center Way
Madison, WI 53713

Dane County / Dept. of Public Works, Highway & Transportation
Public Works Engineering Division
1919 Alliant Energy Center Way; Madison, Wisconsin 53713
J. Eric Urtes p: 608.266.4798

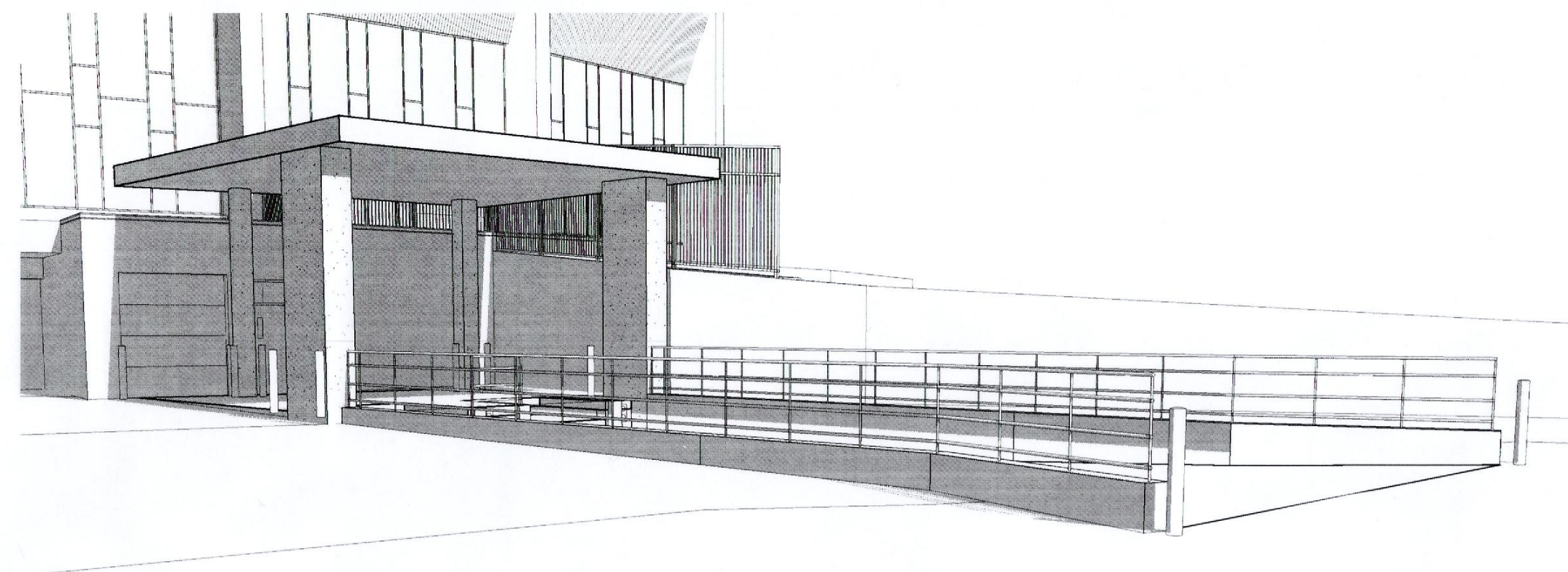

RENDERING IS REPRESENTATIVE ONLY - SEE DOCUMENTS FOR ALL BUILDING INFORMATION
PROJECT RENDERING/PERSPECTIVE/ELEVATION

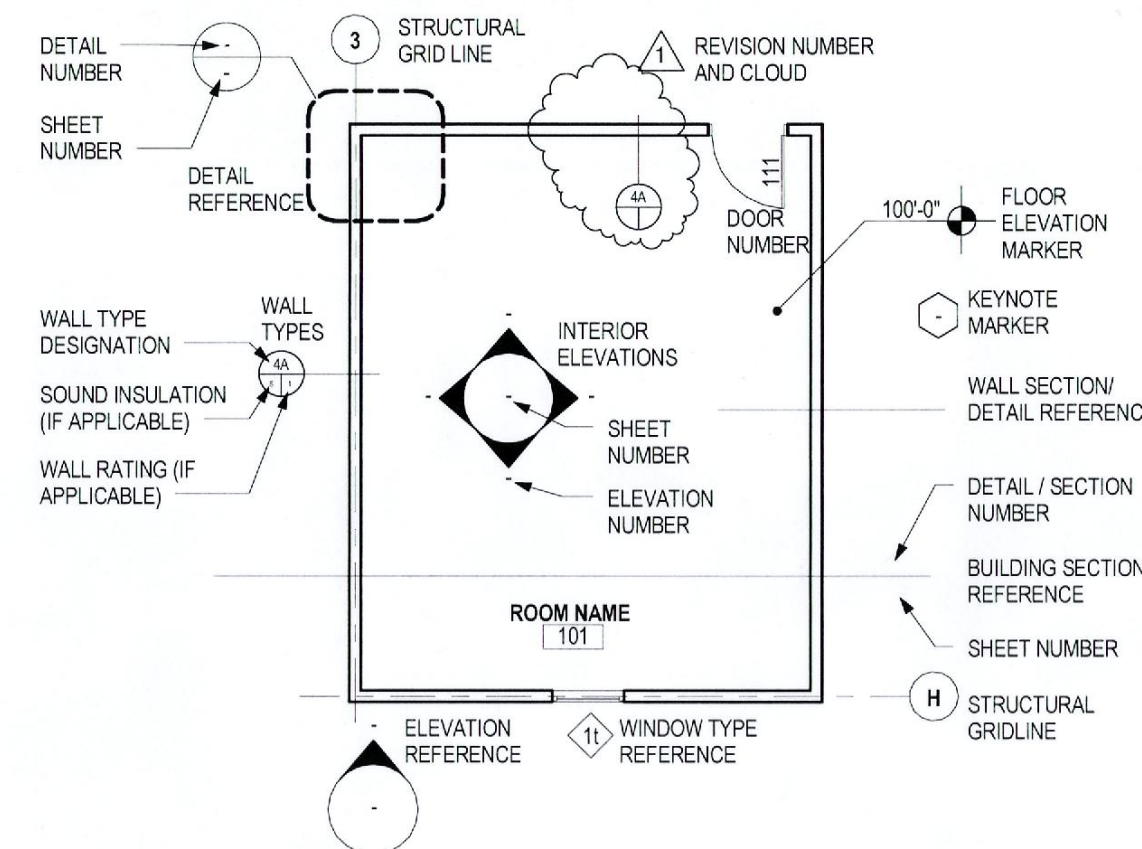

Architecture :

Dimension IV - Madison Design Group
6515 Grand Teton Plaza, Suite 120, Madison, WI 53719
p: 608.829.4444 www.dimensionivmadison.com

Structural Engineering:

Strategic Structural Design, LLC
8517 Excelsior Drive, Suite 201, Madison, WI 53717
p: 608.658.0436 www.strategicstructural.com

Plumbing & Elec. Engineering:

Mike Hein, Hein Engineering Group
17 Applegate Ct., Madison WI 53713
p: 608.658.0436



SITE LOCATION
STATE MAP

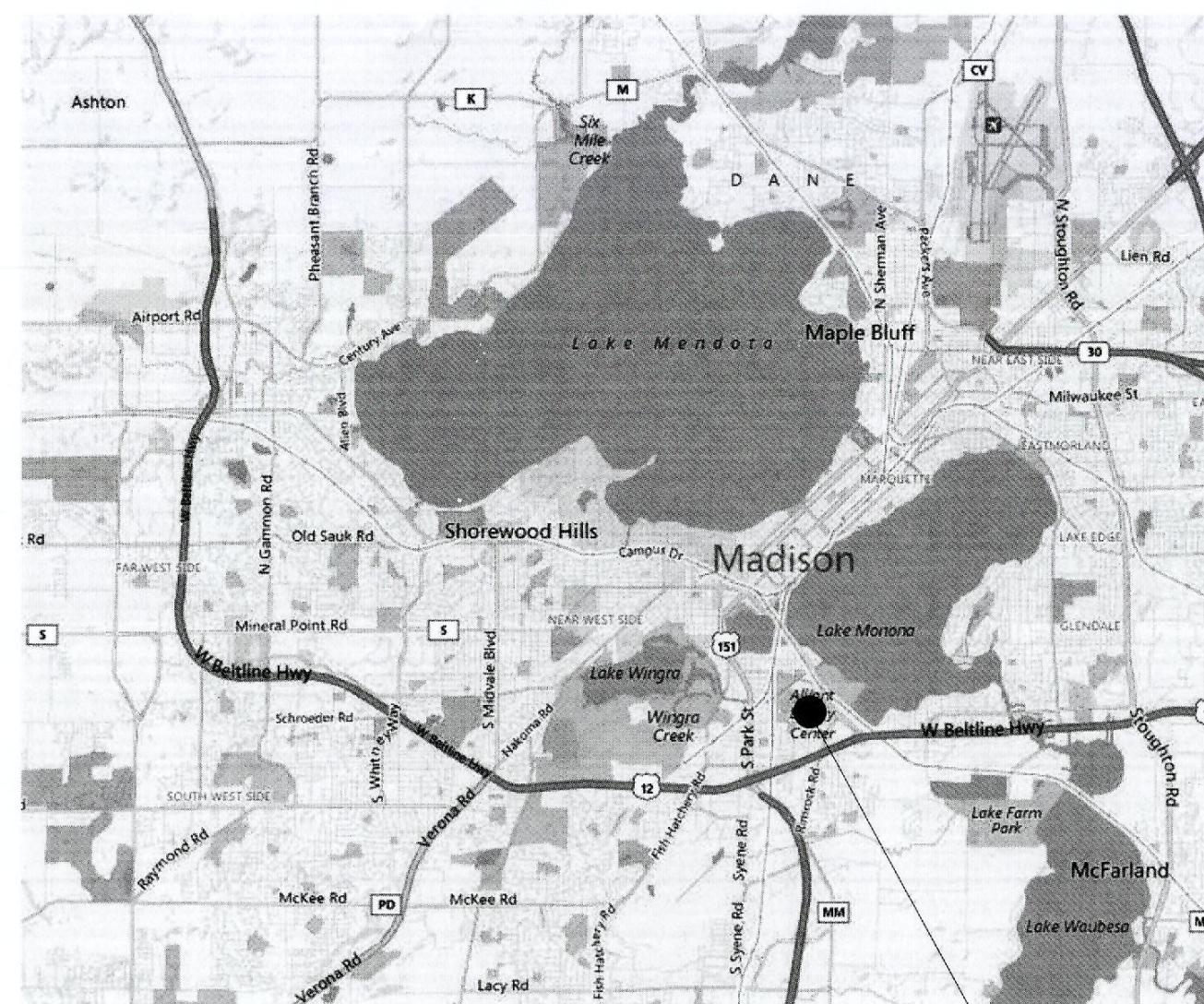

DRIVING DIRECTIONS:
BELTLINE 12 & 18 TO RIMROCK RD
EXIT, LEFT ON ALLIANT ENERGY
CENTER WAY, RIGHT AT ARENA

CITY MAP

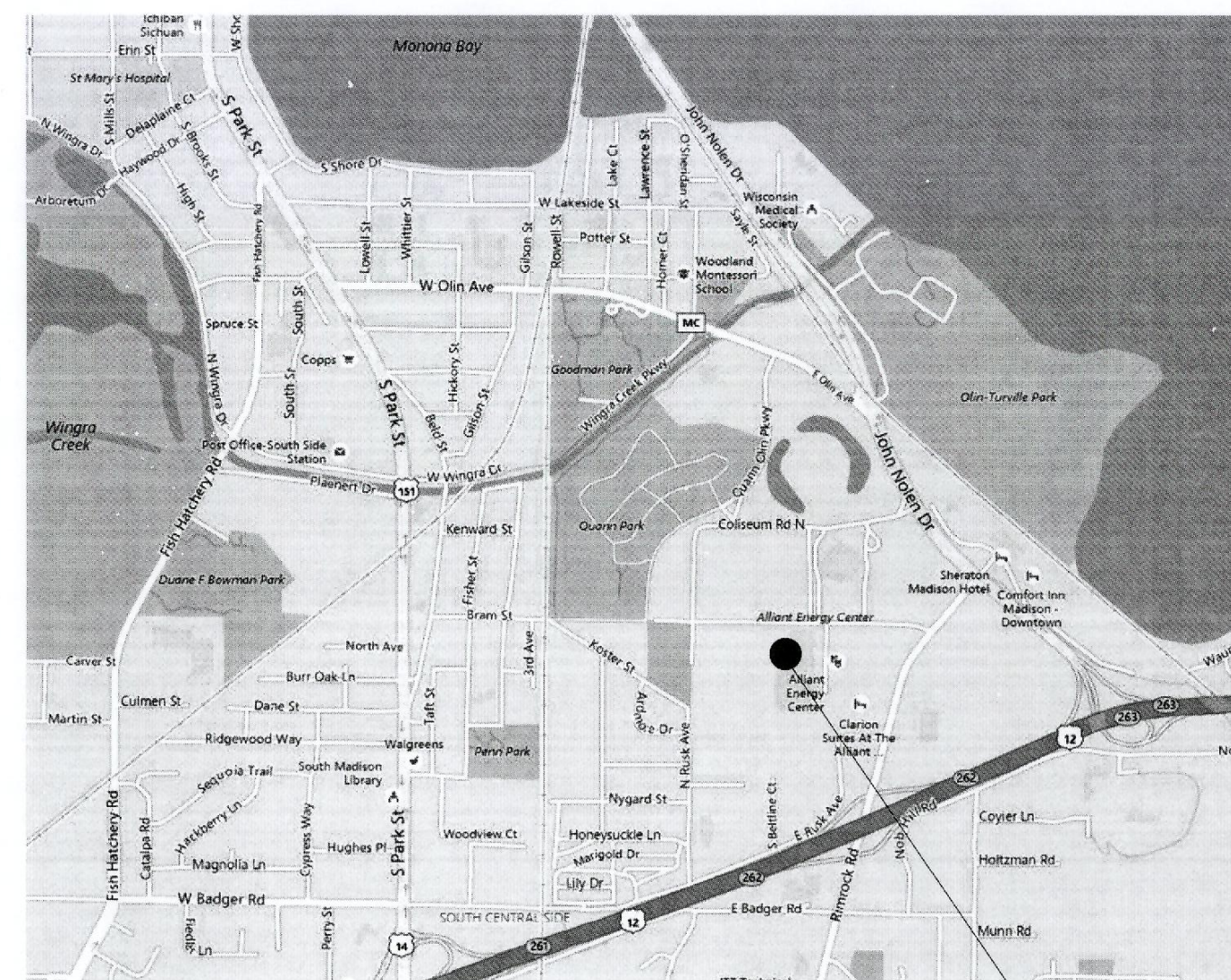

PROJECT SITE MAP

PROJECT/BUILDING DATA

2 BAY LOADING DOCK
PROJECT AREA
TOTAL BUILDING AREA = 2,280

CODE INFORMATION SUMMARY:

APPLICABLE CODE
2009 WISCONSIN COMMERCIAL BUILDING CODE
CONSTRUCTION TYPE
TYPE IIB = 1 STORY STRUCTURE
OCCUPANCY
U - UTILITY AND MISCELLANEOUS
FIRE RESISTANCE RATING BUILDING ELEMENTS
STRUCTURAL FRAME (COLUMNS) = 1 HOUR
ROOF = 1 HOUR
FIRE SPRINKLER
BUILDING IS NOT SPRINKLERED
ALLOWABLE AREA AND HEIGHT SUMMARY
ALLOWABLE AREA = 8,500 SF
ALLOWABLE HEIGHT = 2 STORIES

LIST OF DRAWINGS

- GENERAL
- G0.1 COVER SHEET
- CIVIL
- 1 TOPOGRAPHIC SURVEY & UTILITY MAP
- C1.0 SITE PLAN
- C1.1 SITE PAVING PLAN
- STRUCTURAL
- S001 STRUCTURAL GENERAL NOTES
- S002 STRUCTURAL GENERAL NOTES
- S101 FOUNDATION PLAN
- S201 ROOF FRAMING PLAN
- S301 STRUCTURAL DETAILS
- S302 STRUCTURAL DETAILS
- S303 STRUCTURAL DETAILS
- S304 STRUCTURAL DETAILS
- ARCHITECTURAL
- A1.0 FLOOR & ROOF PLAN
- A2.0 ELEVATIONS, SECTIONS & DETAILS
- PLUMBING
- P1.1 FLOOR PLAN - PLUMBING
- ELECTRICAL
- E1.1 FLOOR PLAN - ELECTRICAL

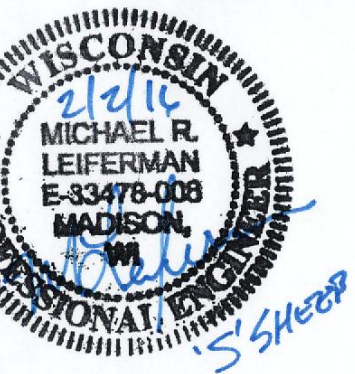
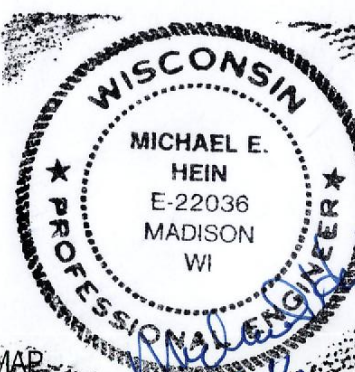

File: I:\2015\156819\DWG\156819_TU_Map.dwg Layout: 22x34 TU MAP User: tluhr Plotted: May 22, 2015 8:51am Xref's:

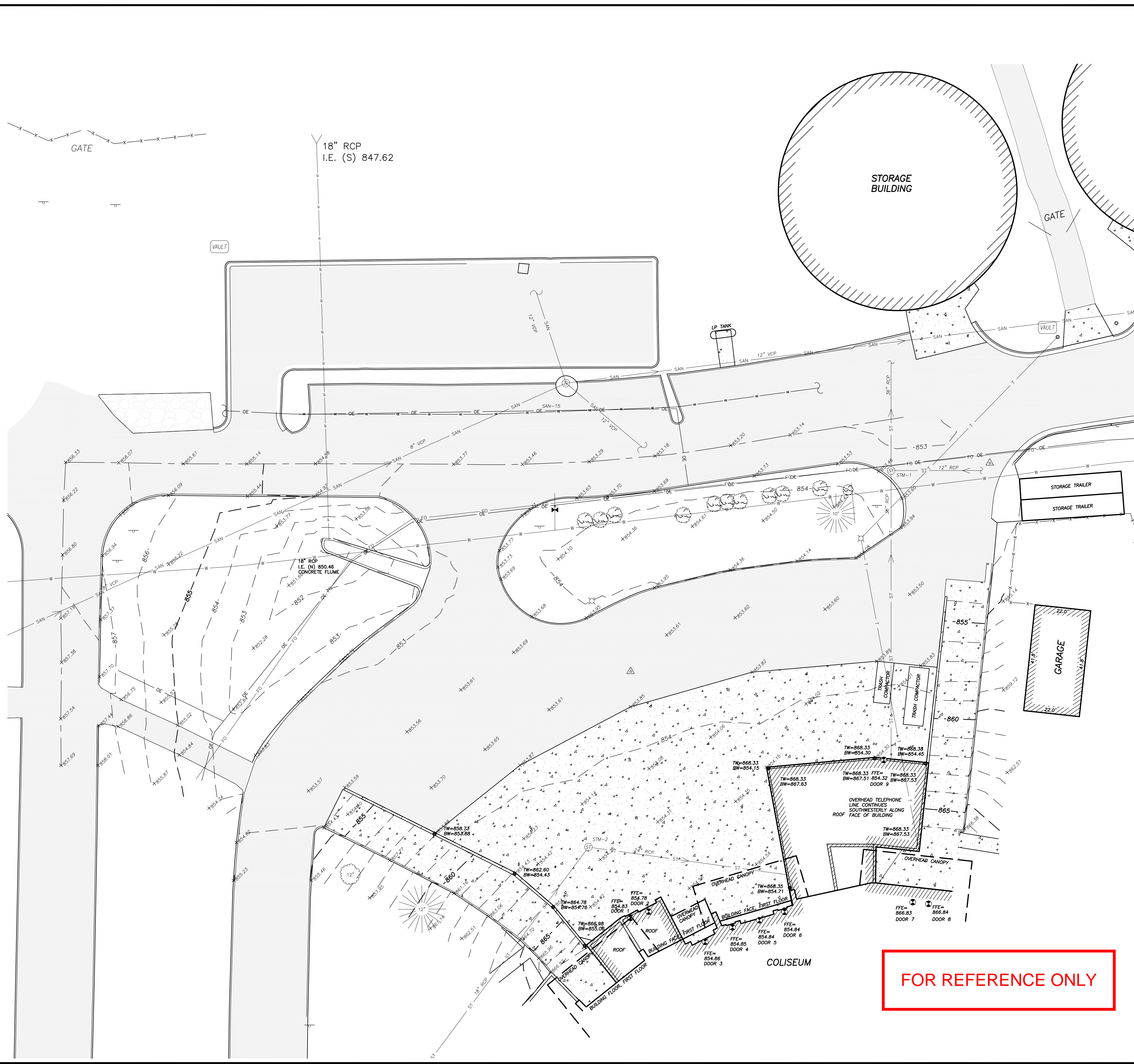

LEGEND

- ⊕ GOVERNMENT CORNER
- ⊙ BENCHMARK
- ⊕ SOIL BORING
- ⊕ MONITORING WELL
- ⊕ BOLLARD
- ⊕ SIGN
- ⊕ SANITARY MANHOLE
- ⊕ CLEAN OUT
- ⊕ WATER MANHOLE
- ⊕ HYDRANT
- ⊕ CURB STOP/SERVICE VALVE
- ⊕ WELL
- ⊕ WATER SPIGOT
- ⊕ WATER OR GAS VALVE
- ⊕ STORM MANHOLE
- ⊕ ROUND CASTED INLET
- ⊕ ENDWALL/END OF PIPE
- ⊕ GAS REGULATOR/METER
- ⊕ CABLE MANHOLE
- ⊕ MANHOLE
- ⊕ ELECTRIC METER
- ⊕ ELECTRIC TRANSFORMER
- ⊕ ELECTRIC MANHOLE
- ⊕ LIGHT POLE
- ⊕ UTILITY POLE
- ⊕ VAULT
- ⊕ TELEPHONE PEDESTAL
- ⊕ FLAG POLE
- ⊕ DECIDUOUS TREE
- ⊕ CONIFEROUS TREE
- ⊕ STUMP
- ⊕ BUSH
- ⊕ EDGE OF WOODS OR BRUSH
- ⊕ FENCE LINE
- ⊕ EDGE OF PAVEMENT
- ⊕ CONCRETE CURB & GUTTER
- ⊕ EDGE OF GRAVEL
- ⊕ SANITARY SEWER
- ⊕ WATER LINE
- ⊕ STORM SEWER
- ⊕ NATURAL GAS
- ⊕ UNDERGROUND ELECTRIC
- ⊕ UNDERGROUND AUDIO
- ⊕ UNDERGROUND 2" CONDUIT (EMPTY)
- ⊕ OVERHEAD ELECTRIC
- ⊕ UNDERGROUND TELEPHONE
- ⊕ BUILDING
- ⊕ BUILDING OVERHANG OR ROOF ONLY
- ⊕ SHORE LINE
- ⊕ WALL LINE
- ⊕ -855- INDEX CONTOUR
- ⊕ -856- INTERMEDIATE CONTOUR
- ⊕ SPOT ELEVATION
- ⊕ BITUMINOUS PAVEMENT
- ⊕ CONCRETE PAVEMENT
- ⊕ GRAVEL OR ROCK
- ⊕ DISCONTINUED MAPPED PIPE LINE

NOTES

- FIELD WORK PERFORMED BY JSD PROFESSIONAL SERVICES, INC. ON MAY 07, 2015.
- THIS SURVEY AND MAP ARE BASED ON THE WISCONSIN COUNTY COORDINATE SYSTEM, (WCCS), DANE COUNTY.
- ELEVATIONS ARE BASED ON NORTH AMERICAN VERTICAL DATUM OF 1988(1991), (NAVD88). PROJECT BENCH MARK IS THE TOP NUT OF A FIRE HYDRANT AT THE NORTHEAST CORNER OF THE NORTH PARKING LOT, JUST WEST OF THE SITE, ELEVATION = 858.33
- CONTOUR INTERVAL IS ONE FOOT.
- ELEVATIONS ALONG CURB AND GUTTER ARE TOP BACK OF CURB.
- THE ACCURACY OF THE BENCHMARKS SHOWN ON THIS MAP SHALL BE VERIFIED BEFORE BEING UTILIZED. JSD PROFESSIONAL SERVICES, INC. DOES NOT WARRANT THE ACCURACY OF THESE BENCHMARKS.
- SUBSURFACE UTILITIES AND FEATURES SHOWN ON THIS MAP HAVE BEEN APPROXIMATED BY LOCATING SURFICIAL FEATURES AND APPURTENANCES, LOCATING DIGGERS HOTLINE FIELD MARKINGS AND BY REFERENCE TO UTILITY RECORDS AND MAPS PROVIDED BY DANE COUNTY. DIGGER'S HOTLINE TICKET NO. 20151824559.
- BEFORE EXCAVATION, APPROPRIATE UTILITY COMPANIES SHOULD BE CONTACTED. FOR EXACT LOCATION OF UNDERGROUND UTILITIES, CONTACT DIGGERS HOTLINE, AT 1.800.242.8511.
- SITE LIGHTING WAS NOT MARKED IN THE FIELD AT THE TIME THIS SURVEY WAS COMPLETED AND NO RECORDS WERE PROVIDED.

SANITARY SEWER MANHOLES					
STRUCT. ID	RIM ELEVATION	INVERT	ELEVATION	PIPE SIZE	PIPE TYPE
SAN-15	853.59	SW	841.33	12"	VCP
		NW	850.34	12"	VCP
		SE	846.61	12"	VCP
		NE	841.25	12"	VCP
		N	841.23	12"	VCP
SAN-17	853.66	SW	848.24	4"	PVC
		SE	845.76	4"	PVC
		N	845.72	4"	PVC
		NE	841.23	12"	VCP

STORM SEWER MANHOLES					
STRUCT. ID	RIM ELEVATION	INVERT	ELEVATION	PIPE SIZE	PIPE TYPE
STM-2	861.76	S	849.58	24"	RCP
		NE	849.56	18"	RCP
STM-3	854.24	SW	849.08	18"	RCP
		SE	849.02	24"	RCP
STM-4	853.11	S	847.81	36"	RCP
		E	848.51	12"	RCP
		N	847.69	36"	RCP

DOOR WIDTHS		
DOOR NO.	WIDTH	TYPE
DOOR 1	3.35'	ENTRY
DOOR 2	7.95'	OVERHEAD
DOOR 3	10.0'	OVERHEAD
DOOR 4	3.7"	ENTRY
DOOR 5	13.5'	OVERHEAD
DOOR 6	3.7"	ENTRY
DOOR 7	13.4'	ENTRY
DOOR 8	10.0'	OVERHEAD
DOOR 9	3.7"	ENTRY

FOR REFERENCE ONLY

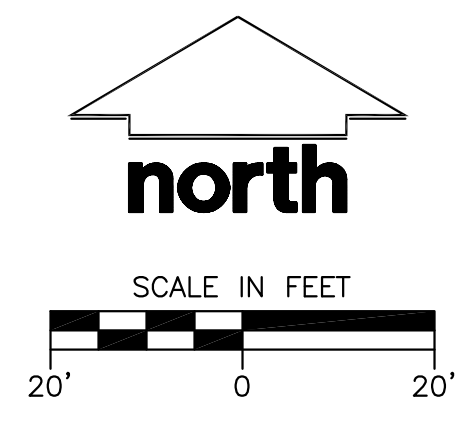

JSD Professional Services, Inc.
 Engineers • Surveyors • Planners

"BUILDING RELATIONSHIPS WITH A COMMITMENT TO CLIENT SATISFACTION THROUGH TRUST, QUALITY AND EXPERIENCE"

- CIVIL ENGINEERING
- SURVEYING & MAPPING
- CONSTRUCTION SERVICES
- WATER RESOURCES
- PLANNING & DEVELOPMENT
- TRANSPORTATION ENGINEERING
- STRUCTURAL ENGINEERING
- LANDSCAPE ARCHITECTURE

MADISON REGIONAL OFFICE
 161 HORIZON DRIVE, SUITE 101
 VERONA, WISCONSIN 53593
 608.848.5060 PHONE | 608.848.2255 FAX

MADISON | MILWAUKEE
 KENOSHA | APPLETON

www.jsdinc.com

SERVICES PROVIDED TO:
DANE COUNTY PUBLIC WORKS

PROJECT:
COLISEUM LOADING DOCK

PROJECT LOCATION:
 TOWN OF MADISON
 DANE COUNTY, WI
 JSD PROJECT NO.: 15-6819

SEAL/SIGNATURE:

DESIGN: _____
 DRAWN: _____
 APPROVED: _____

PLAN MODIFICATIONS: _____ DATE: _____

SANITARY SEWER MANHOLES	
STRUCT. ID	RIM ELEVATION
SAN-15	853.59
SAN-17	853.66

DIGGERS HOTLINE

Call 811 or (800) 242-8511
 Milwaukee Area (262) 432-7910
 Hearing Impaired TDD (800) 542-2289
www.DiggersHotline.com

SHEET TITLE:
TOPOGRAPHIC & UTILITY MAP

MAP NO: C-387
 SHEET NUMBER: 1

THESE PLANS AND DESIGNS ARE COPYRIGHT PROTECTED AND MAY NOT BE USED IN WHOLE OR IN PART WITHOUT THE WRITTEN CONSENT OF JSD PROFESSIONAL SERVICES, INC.

COLISEUM LOADING DOCKS - ALLIANT ENERGY CENTER

1919 Alliant Energy Center Way
Madison, WI 53713

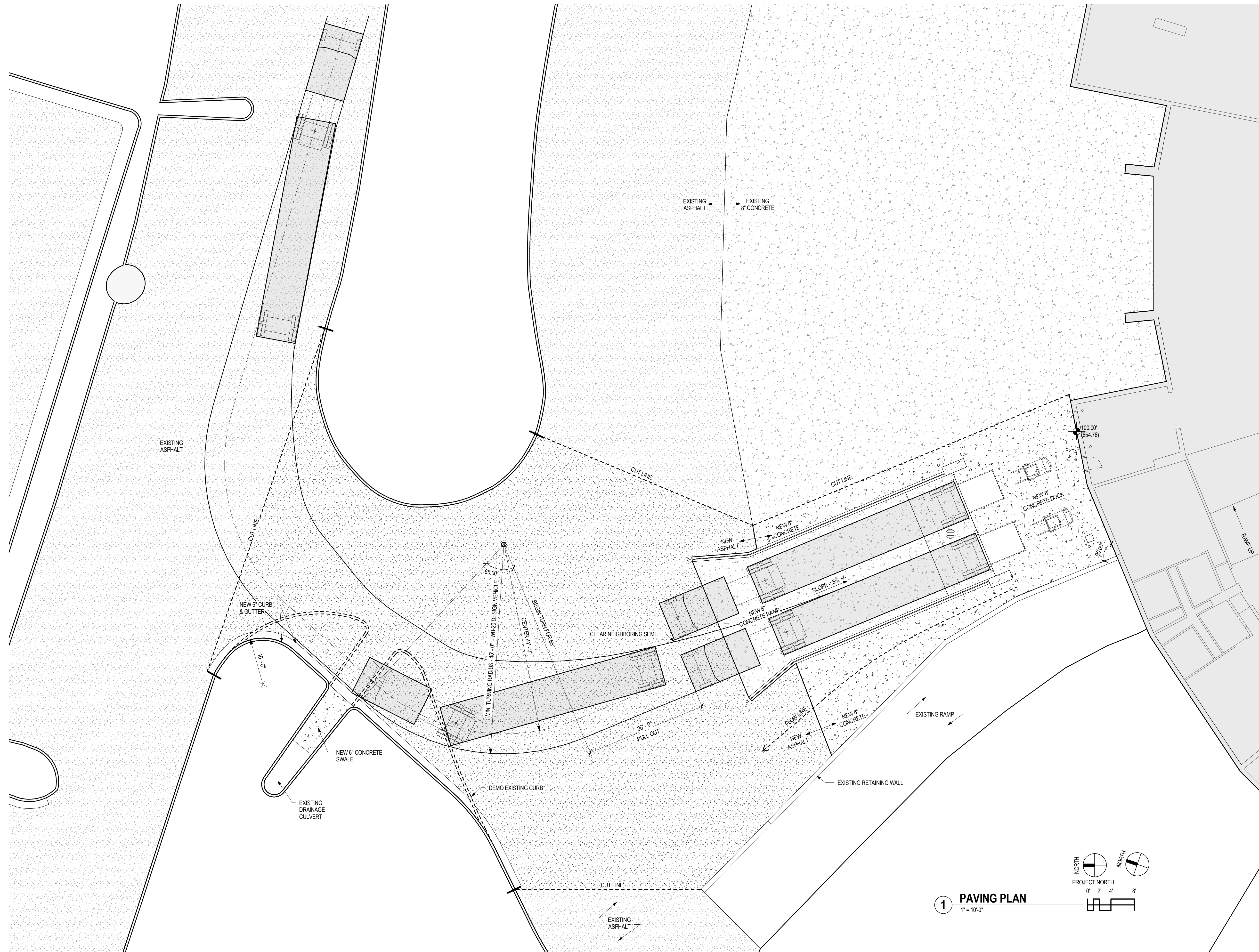

DATE OF ISSUE: 2/4/2016

REVISIONS:

NO.	DESCRIPTION

PROJECT # 15019
REQUEST FOR BID # 316001

SITE PAVING PLAN

1 PAVING PLAN
1" = 10'-0"

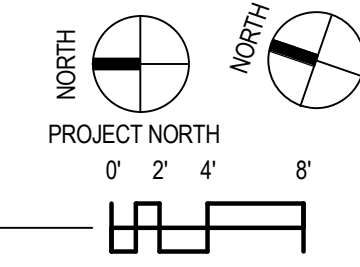

C1.1

STRUCTURAL SHEET INDEX			
SHEET NUMBER	SHEET NAME	CURRENT REVISION DATE	CURRENT REVISION DESCRIPTION
S001	STRUCTURAL GENERAL NOTES		
S002	STRUCTURAL GENERAL NOTES		
S101	FOUNDATION PLAN		
S201	ROOF FRAMING PLAN		
S301	STRUCTURAL DETAILS		
S302	STRUCTURAL DETAILS		
S303	STRUCTURAL DETAILS		
S304	STRUCTURAL DETAILS		

GENERAL NOTES

- THE CONTRACTOR IS RESPONSIBLE FOR JOB SITE SAFETY REQUIREMENTS.
- THE BUILDING STRUCTURE IS DESIGNED TO FUNCTION AS A COMPLETE SYSTEM, AND HAS NOT BEEN ANALYZED OR DESIGNED FOR STABILITY DURING ERECTION. IT IS THE RESPONSIBILITY OF THE CONTRACTOR TO DESIGN AND PROVIDE ADEQUATE TEMPORARY BRACING TO INSURE STABILITY DURING THE ERECTION PROCESS.
- THE CONTRACTOR IS RESPONSIBLE FOR CONSTRUCTION MEANS AND METHODS, AND IS RESPONSIBLE TO INSURE THAT CONSTRUCTION LOADS DO NOT EXCEED THE DESIGN CAPACITY OF THE FRAMING ELEMENTS WHEN THOSE LOADS ARE APPLIED.
- DO NOT SCALE THE DRAWINGS.
- THE CONTRACTOR IS REQUIRED TO COORDINATE THE STRUCTURAL DRAWINGS WITH THE ARCHITECTURAL, CIVIL, MECHANICAL, ELECTRICAL, AND PLUMBING DRAWINGS, AND TO BRING ANY DISCREPANCIES, INTERFERENCES, DIMENSIONAL INCONSISTENCIES, OR CONCERNS ASSOCIATED WITH THIS COORDINATION TO THE ARCHITECT AND ENGINEER IMMEDIATELY.

DESIGN LOADS

APPLICABLE DESIGN CODE AND REFERENCES

THE CODES AND STANDARDS LISTED HAVE BEEN USED FOR THE DESIGN OF THIS PROJECT. ALL CONSTRUCTION, FABRICATION, AND MATERIALS SHALL CONFORM TO THESE CODES AND STANDARDS.

2009 INTERNATIONAL BUILDING CODE WITH WISCONSIN AMMENDMENTS
 ASCE 7-05 MINIMUM DESIGN LOADS FOR BUILDINGS
 ACI 318-05 BUILDING CODE REQUIREMENTS FOR STRUCTURAL CONCRETE
 AISC 360-05 SPECIFICATION FOR STRUCTURAL STEEL BUILDINGS

BUILDING DESIGN CRITERIA

BUILDING OCCUPANCY CATEGORY: II (SEE ASCE 7-05 TABLE 1-1)

BUILDING DESIGN LOADS AND DATA

DEAD LOADS
 ROOF 218 PSF

LIVE LOADS
 TYPICAL FLOOR 100 PSF
 FORK LIFT CLARK CQ30 6000LB CAP / 14000 LB MAX AXLE LOAD

ROOF LIVE LOADS

TRIB. AREA < 200 SF 20 PSF
 TRIB. AREA > 600 SF 12 PSF
 ROOF LIVE LOADS FOR A MEMBER WITH TRIBUTARY BETWEEN 200 SF AND 600 SF MAY BE DETERMINED USING LINEAR INTERPOLATION.

SNOW

GROUND SNOW (Pg) 30 PSF
 SNOW IMPORTANCE FACTOR, (I) 1.0
 EXPOSURE FACTOR (Ce) 1.2

MAIN ROOF

THERMAL FACTOR (Ct) 1.2
 FLAT ROOF SNOW (P) 30 PSF

SEE SNOW DRIFT SURCHARGE PLAN **1** FOR ADDITIONAL SNOW LOADS REQ'D.
 5002

WIND DESIGN DATA

BASIC WIND SPEED 90 MPH
 WIND IMPORTANCE FACTOR 1.0
 DIRECTIONALITY FACTOR (Kd) 0.85
 TOPOGRAPHY FACTOR (Kzt) 1.0
 WIND EXPOSURE B
 ENCLOSURE CLASSIFICATION OPEN
 INTERNAL PRESSURE COEFFICIENT +/- 0.18

SEISMIC DESIGN DATA

SOIL DESIGN DATA

ALLOWABLE SOIL BEARING PRESSURE 5,000 PSF SOIL BEARING: FIELD VERIFY
 10,000 PSF ROCK BEARING: FIELD VERIFY
 (1/3 INCREASE ALLOWED FOR IMPACT FROM SNOW)
 COEFFICIENT OF SLIDING FRICTION (μ) 0.30
 LATERAL EARTH PRESSURES
 ACTIVE PRESSURE COEFFICIENT, Ka 0.28
 PASSIVE PRESSURE COEFFICIENT, Kp 3.5
 ANGLE OF INTERNAL FRICTION 34°

ALLOWABLE DEFLECTION CRITERIA

ROOF L/360 LIVE; L/240 TOTAL

COMPONENTS & CLADDING WIND DESIGN PRESSURES				
ROOFS	TRIBUTARY AREA = 10 SF	POSITIVE (PSF)		NEGATIVE (PSF)
		ZONE 1	6.4	-15.1
	ZONE 2	10.1	-22.7	
	ZONE 3	10.1	-22.7	
ROOFS	TRIBUTARY AREA = 100 SF	POSITIVE (PSF)		NEGATIVE (PSF)
		ZONE 1	6.4	-15.1
	ZONE 2	6.4	-15.1	
	ZONE 3	6.4	-15.1	

FOUNDATION NOTES

- THE FOUNDATIONS HAVE BEEN DESIGNED BASED ON ASSUMED SOIL BEARING CAPACITIES INDICATED, AND SHALL BE CONFIRMED IN THE FIELD.
- SEE PLAN FOR ELEVATION DATUM EQUAL TO FIRST FLOOR TOP OF CONCRETE (ELEVATION 100'-0").
- DO NOT UNDERMINE EITHER NEW OR EXISTING CONSTRUCTION.
- BEAR ALL FOOTINGS ON UNDISTURBED SOIL OR COMPACTED FILLS HAVING A MINIMUM NET ALLOWABLE BEARING CAPACITY INDICATED IN SOIL DESIGN DATA.
- REMOVE TOPSOIL, ORGANICS, AND UNSUITABLE MATERIAL, AS DIRECTED BY THE OWNERS GEOTECHNICAL CONSULTANT, AND STOCKPILE AS REQUIRED FOR FINAL GRADING. PLACE ENGINEERED FILL AS REQUIRED IN HORIZONTAL LIFTS WITHIN +/-2 PERCENT OF OPTIMUM MOISTURE CONTENT. COMPACT TO THE SPECIFIED DENSITY REQUIREMENTS.
- MINIMIZE CONSTRUCTION TRAFFIC OVER EXPOSED SUBGRADES IF WET. DO NOT ALLOW WATER TO POND ON THE SUBGRADES.
- THE OWNER'S GEOTECHNICAL CONSULTANT MUST REVIEW AND APPROVE ALL FINISHED EXCAVATIONS AND BEARING SUBGRADES BEFORE PLACING CONCRETE. PROVIDE ADDITIONAL EXCAVATION AS NECESSARY TO ACHIEVE THE REQUIRED BEARING CAPACITY.
- USE SIDE FORMS FOR ALL FOOTINGS AND GRADE BEAMS. CLEAN REINFORCEMENT IMMEDIATELY PRIOR TO PLACING CONCRETE.
- DO NOT PLACE CONCRETE IN ANY EXCAVATION CONTAINING FREE WATER, FROST, ICE OR FROZEN MATERIALS. PREVENT FROST OR ICE FROM PENETRATING ANY FOOTING OR SLAB SUBGRADE, BOTH BEFORE AND AFTER CONCRETE PLACEMENT AND UNTIL FOOTINGS OR SUBGRADES ARE FULLY PROTECTED BY THE PERMANENT BUILDING STRUCTURE.
- PLACE THE CONCRETE FOR EACH FOOTING IN ONE CONTINUOUS POUR.
- BACKFILL FOUNDATION WALLS AND GRADE BEAMS DURING THE OPERATION OF BACKFILLING AND COMPACTION.
- BACKFILL AGAINST FOUNDATION WALLS SHALL BE PLACED IN LIFTS SUCH THAT THE DIFFERENCE IN ELEVATION ON OPPOSITE SIDES OF THE WALL DOES NOT EXCEED 1'-6".
- PER GEOTECHNICAL REPORT, ANY FOOTINGS PLACED DURING WINTER CONSTRUCTION SHALL BE PLACED A MINIMUM OF 60" BELOW EXTERIOR GRADE. IF FOUNDATIONS WILL BE PLACED DURING WINTER CONSTRUCTION, CONTRACTOR SHALL BE RESPONSIBLE FOR ALL ADDITIONAL COSTS ASSOCIATED WITH LOWERING FOOTING ELEVATIONS.

BAR SIZE	4,000 PSI CONCRETE				
	DEVELOPMENT LENGTHS		CLASS 'B' TENSION LAP SPlice LENGTHS		STD HOOK DEVELOPMENT LENGTH, L _{dh}
	STANDARD	TOP BAR	STANDARD	TOP BAR	
#3	12"	12"	16"	16"	6"
#4	12"	15"	16"	20"	7"
#5	15"	19"	19"	24"	9"
#6	18"	23"	23"	29"	10"
#7	29"	37"	37"	48"	12"
#8	36"	47"	47"	61"	14"
#9	44"	57"	57"	75"	15"
#10	54"	70"	70"	91"	17"
#11	65"	84"	84"	109"	19"

- NOTES:
 1. TOP BARS ARE DEFINED AT HORIZONTAL BARS WITH MORE THAN 12" OF CONCRETE BELOW.
 2. TABLE VALUES BASED ON 1 1/2" CLEAR COVER AND MINIMUM CENTER TO CENTER BAR SPACING OF 6".
 3. SPLICE LENGTH SHALL BE BASED ON LARGER BAR BEING SPLICED.
 4. HOOKED BAR EXTENSION = MIN. BEND DIAMETER + 12db.
 5. MIN. BEND DIAMETER = 6db FOR #3 - #8
 8db FOR #9 - #11
 6. HOOKED BAR DEVELOPMENT LENGTHS, L_{dh}, ASSUME
 a) SIDE COVER ≥ 2 1/2" AND
 b) COVER AT END OF EXTENSION ≥ 2"

1 REBAR LAP SPLICE LENGTHS 1' = 1'-0"

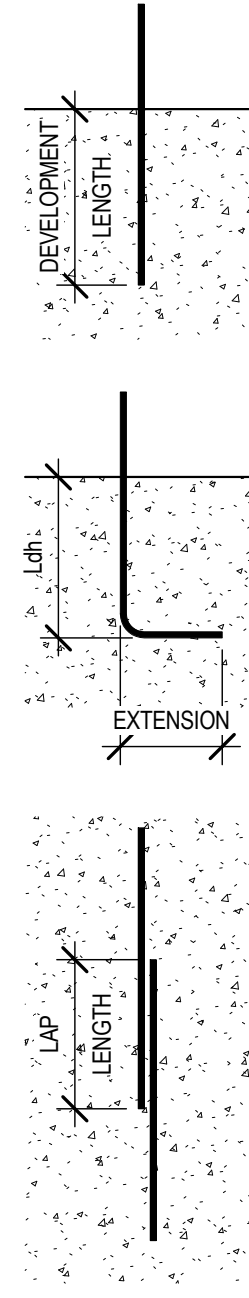

ABBREVIATIONS

ACI	AMERICAN CONCRETE INSTITUTE	JT	JOINT
ADJ	ADJACENT	K	KIPS
ADDL	ADDITIONAL	KSF	KIPS PER SQUARE FOOT
AESS	ARCHITECTURAL EXPOSED STRUCTURAL STEEL	KSI	KIPS PER SQUARE INCH
AF&PA	AMERICAN FOREST & PAPER ASSOCIATION	L	ANGLE
AISC	AMERICAN INSTITUTE OF STEEL CONSTRUCTION	LB(S)	POUND(S)
ALT	ALTERNATE	LL	LIVE LOAD
ALUM	ALUMINUM	LLBB	LONG LEG BACK TO BACK
APA	AMERICAN PLYWOOD ASSOCIATION	LLH	LONG LEG HORIZONTAL
APPROX	APPROXIMATE	LLV	LONG LEG VERTICAL
AR	ANCHOR ROD	LP	LOW POINT
ARCH	ARCHITECTURAL	LW	LONG WAY
ASCE	AMERICAN SOCIETY OF CIVIL ENGINEERS	LTWT	LIGHT WEIGHT
ASTM	AMERICAN SOCIETY OF TESTING AND MATERIALS	MAX	MAXIMUM
AWS	AMERICAN WELDING SOCIETY	MO	MASONRY OPENING
B/	BOTTOM OF	MS	MIDDLE STRIP
BFR	BLENDED FIBER REINFORCING	MATL	MATERIAL
BLDG	BUILDING	MAX	MAXIMUM
BLKG	BLOCK (ING)	MECH	MECHANICAL
BOT	BOTTOM	MEP	MECHANICAL ELECTRICAL AND PLUMBING
B PL	BASE PLATE	MIN	MINIMUM
BM	BEAM	MISC	MISCELLANEOUS
BRG	BEARING	MFR	MANUFACTURER
BSMT	BASEMENT	NIC	NOT IN CONTRACT
B/TWN	BETWEEN	NTS	NOT TO SCALE
CS	CENTER OF GRAVITY	NOM	NOMINAL
CL	CENTERLINE	NO	NUMBER
CIP	CAST-IN-PLACE	NS	NEAR SIDE
CJ	CONTROL OR CONSTRUCTION JOINT	OC	ON CENTER
CJP	COMPLETE JOINT PENETRATION	OPNG	OPENING
CLR	CLEAR	OD	OUTSIDE DIAMETER
CMU	CONCRETE MASONRY UNIT	OF	OUTSIDE FACE
CO	CLEAN OUT	OPP	OPPOSITE
COL	COLUMN	PL	PLATE
CONC	CONCRETE	PC	PRECAST CONCRETE
CONN	CONNECT (ION)	PCA	PORTLAND CEMENT ASSOCIATION
CONT	CONTINUOUS OR CONTINUE	PCAP	PILE CAP
CONST JT	CONSTRUCTION JOINT	PCF	POUNDS PER CUBIC FOOT
CRSI	CONCRETE REINFORCING STEEL INSTITUTE	PSI	POUNDS PER SQUARE INCH
CS	COLUMN STRIP	PSF	POUNDS PER SQUARE FOOT
CU YD	CUBIC YARD	PCC	PRECAST CONCRETE
DBA	DOWEL BAR ANCHOR	PEN	PENETRATION
DET	DETAIL	PERIM	PERIMETER
DIA	DIAMETER	PJP	PARTIAL JOINT PENETRATION
DIAG	DIAGONAL	PL	PLATE
DIM	DIMENSION	PSF	POUNDS PER SQUARE FOOT
D/L	DEAD LOAD	PSI	POUNDS PER SQUARE INCH
DWG	DRAWING	PT	POST TENSIONED
EA	EACH	PT	PRESSURE TREATED
EE	EACH END	PVC	POLYVINYL CHLORIDE
EF	EACH FACE	QTY	QUANTITY
EL	ELEVATION	R	RADIUS
ELEV	ELEVATOR	REF	REFERENCE
ELEC	ELECTRICAL	REIN	REINFORCE (D) (ING)
ES	EACH SIDE	REQD	REQUIRED
EW	EACH WAY	REV	REVISION
EQ	EQUAL	RD	ROUGH OPENING
EOD	EDGE OF DECK	RO	ROUGH OPENING
EOS	EDGED OF SLAB	SCHED	SCHEDULE
EXIST	EXISTING	SLIP C	SLIP CRITICAL
EXT	EXTERIOR	SECT	SECTION
EXP	EXPANSION	SER	STRUCTURAL ENGINEER OF RECORD
EJ	EXPANSION JOINT	SIM	SIMILAR
FD	FLOOR DRAIN	SJ	SEISMIC JOINT
FIN	FINISH	SQ	SQUARE
FLR	FLOOR	SPEC	SPECIFICATIONS
FND	FOUNDATION	SOG	SLAB-ON-GRADE
FP	FULL PENETRATION	SS	STAINLESS STEEL
FS	FAR SIDE	SSL	SHORT SLOT
FT	FOOT/FEET	STD	STANDARD
FTG	FOOTING	STIFF	STIFFENER
GAGE	GAGE	STL	STEEL
GALV	GALVANIZED	STRUCT	STRUCTURAL
OC	GENERAL CONTRACTOR	SW	SHORT WAY
GB	GRADE BEAM	SYM	SYMMETRICAL
HCA	HEADED CONCRETE ANCHOR	T&B	TOP AND BOTTOM
HLDN	HOLDDOWN	T&G	TONGUE AND GROOVE
HORIZ	HORIZONTAL	T/	TOP OF
HP	HIGH POINT	THK	THICK (NESS)
HS	HIGH STRENGTH	TRANS	TRANSVERSE
HSS	HOLLOW STRUCTURAL SECTION	TYP	TYPICAL
HT	HEIGHT	UNO	UNLESS NOTED OTHERWISE
IBC	INTERNATIONAL BUILDING CODE	VIF	VERIFY IN FIELD
ICC	INTERNATIONAL CODE COUNCIL	VERT	VERTICAL
ID	INSIDE DIAMETER	WP	WORK POINT
IF	INSIDE FACE	W/	WITH
INCH	INCH	W/O	WITHOUT
INFO	INFORMATION	WD	WOOD
INSUL	INSULATED (ION)	WWF	WELDED WIRE FABRIC
INT	INTERIOR	WF	WIDE FLANGE SECTION
INV	INVERT	WT	WIDE FLANGE TEE SECTION

DIMENSION

Madison Design Group
 architecture - engineering - interior design

6515 Grand Teton Plaza, Suite 120
 Madison, Wisconsin 53719
 p608.829.4444 f608.829.4445

dimensionvmadison.com



STRATEGIC STRUCTURAL DESIGN, LLC

8517 EXCELSIOR DRIVE, SUITE 201
 MADISON, WI 53717
 (608) 658-0436

www.strategicstructural.com

SSD PROJECT No. 150107

DANE COUNTY COLISEUM LOADING DOCKS

1919 Alliant Energy Center Way,
 Madison, WI 53713

DATE OF ISSUE: 2/4/2016

REVISIONS:

PROJECT # 15019
 REQUEST FOR BID # 316001

STRUCTURAL GENERAL NOTES

S001

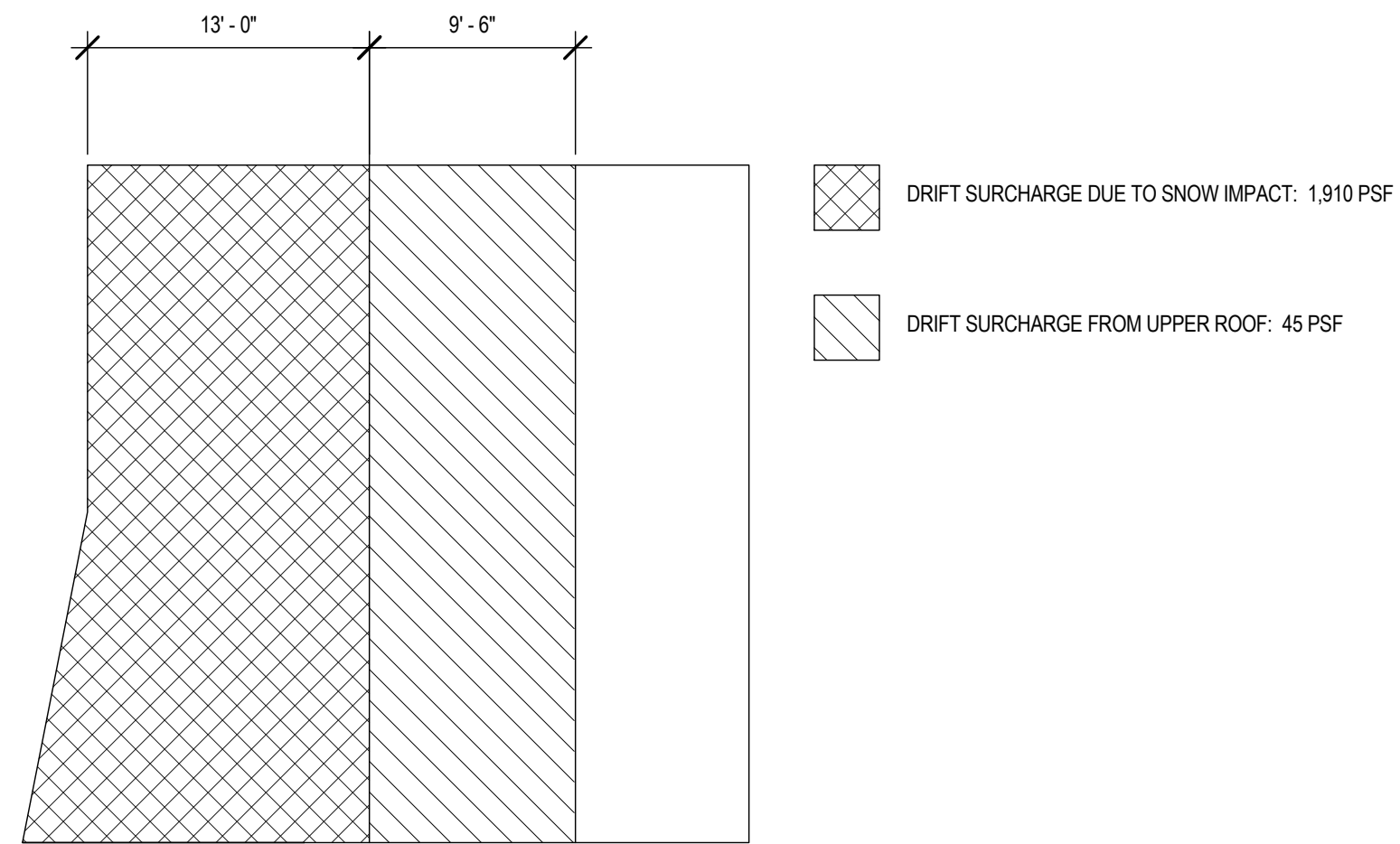

1 SNOW DRIFT SURCHARGE PLAN
1/8" = 1'-0"

CAST IN PLACE CONCRETE NOTES

- SEE SPECIFICATION DIVISION 03 FOR REQUIREMENTS IN ADDITION TO THOSE LISTED BELOW.
- MATERIAL SPECIFICATIONS**
 FOOTINGS Fc = 4000 PSI @ 28 DAYS
 FOUNDATION WALLS AND RETAINING WALLS Fc = 4000 PSI @ 28 DAYS
 SLAB ON GRADE, ROOF SLAB Fc = 5000 PSI @ 28 DAYS
 COLUMNS Fc = 6000 PSI @ 28 DAYS
 GRADE BEAMS Fc = 6000 PSI @ 28 DAYS
 CONCRETE NOT OTHERWISE NOTED Fc = 4000 PSI @ 28 DAYS
 MILD REINFORCING STEEL BARS Fy = 60 KSI; ASTM A615
 HIGH STRENGTH REINFORCING STEEL BARS Fy = 100 KSI; ASTM A615
 FIBER REINFORCING FOR SLABS ASTM C1116; SYNTHETIC MACRO FIBERS
 SLAB REINFORCING BARS SHALL BE EPOXY COATED
- SUBMIT CONCRETE MIX DESIGNS, WITH REQUIRED BACKUP DATA, INCLUDING RECENT GRADATIONS FOR EACH AGGREGATE USED, FOR EACH TYPE OF CONCRETE PROPOSED FOR USE, TO THE ARCHITECT AND ENGINEER FOR REVIEW A MINIMUM OF TWO WEEKS PRIOR TO PLACEMENT. SEE SPECIFICATIONS FOR ADDITIONAL MIX DESIGN REQUIREMENTS. CONCRETE MIXES SUBMITTED SHALL BE DESIGNED TO BE PLACABLE FOR THE TEMPERATURE CONDITIONS AT THE JOBSITE, AND BE ABLE TO BE PLACED AND CONSOLIDATED AROUND THE REINFORCING INDICATED ON THE PLANS. DO NOT USE CALCIUM CHLORIDE IN ANY CONCRETE.
- PROVIDE AIR-ENTRAINING IN CONCRETE AS INDICATED IN THE SPECIFICATIONS.
- ALL CONCRETE SHALL BE NORMAL WEIGHT (APPROX. 145 PCF) UNO.
- SUBMIT DETAILED SHOP DRAWINGS INDICATING REINFORCEMENT SIZE, SPACING, BENDING, AND PLACEMENT TO THE ARCHITECT AND ENGINEER FOR REVIEW PRIOR TO FABRICATION. INCLUDE DETAILS AND LOCATIONS OF ALL CURBS, CONSTRUCTION JOINTS, SLAB DEPRESSIONS, SLEEVES, OPENING, ETC.
- THE MAXIMUM TOTAL AMOUNT OF WATER THAT MAY BE ADDED TO THE MIX AFTER BATCHING IS THE AMOUNT INDICATED AS BEING WITHHELD ON THE BATCH TICKET FOR THE SPECIFIC BATCH.
- SUBMIT ELECTRONIC COPIES OF ALL CONCRETE DELIVERY TICKETS WITHIN 5 DAYS OF PLACEMENT, INDICATING THE FOLLOWING INFORMATION:
 TIME AND NUMBER OF CUBIC YARDS BATCHED
 THEORETICAL TARGET AND ACTUAL BATCH WEIGHTS OF EACH INGREDIENT
 AMOUNT OF WATER WITHHELD
 AMOUNT OF WATER ADDED AT JOBSITE
 MIX DESIGN NUMBER
 STRUCTURE BEING PLACED
 LOCATION OF PLACEMENT
 NUMBER OF REVOLUTIONS AT MIXING SPEED
 TOTAL REVOLUTIONS AT COMPLETION OF DISCHARGE
 TIME AT COMPLETION OF DISCHARGE
 SLUMP AND AIR CONTENT, IF TESTED
 TEMPERATURE OF AIR AND CONCRETE
 SAMPLE NUMBERS OF CYLINDERS MADE FROM LOAD
- DETAIL, FABRICATE, SUPPORT, AND PLACE ALL CONCRETE REINFORCEMENT IN ACCORDANCE WITH ACI 315 "DETAILS AND DETAILING OF CONCRETE REINFORCEMENT" AND ACI 318 "BUILDING CODE REQUIREMENTS FOR STRUCTURAL CONCRETE". FIELD BENDING OF REINFORCING BARS IS NOT PERMITTED EXCEPT WHERE INDICATED ON THE STRUCTURAL DRAWINGS.
- COVERAGE FOR REINFORCEMENT SHALL NOT BE NOT LESS THAN:

CONDITION	COVER
CONCRETE CAST AGAINST AND PERMANENTLY EXPOSED TO EARTH	3"
CONCRETE EXPOSED TO EARTH OR WEATHER #5 BARS AND SMALLER #6 THROUGH #18 BARS	1- 1/2" 2"
CONCRETE NOT EXPOSED TO WEATHER OR IN CONTACT WITH GROUND SLABS, WALLS, & JOISTS #14 & #18 BARS #11 BARS AND SMALLER BEAMS & COLUMNS PRIMARY REINFORCEMENT, TIES, & SPIRALS	1-1/2" 3/4" 1-1/2"

- SEE DETAIL (1) S001 FOR CLASS B TENSION CONTACT LAP SPlice LENGTHS. STAGGER ADJACENT LAPS 3'-0" UNO.
- PROVIDE (2) #5 BARS DIAGONAL AT CORNERS OF OPENINGS AND AT RE-ENTRANT CORNERS. PROVIDE (2) #5 BARS AROUND THE PERIMETER OF OPENINGS WITH SIDES EXCEEDING 18 INCHES IN LENGTH.
- WELDING OF GRADE A615 REINFORCING BARS IS NOT PERMITTED.
- COORDINATE LOCATION OF ALL CONSTRUCTION JOINTS WITH ENGINEER PRIOR TO COMMENCEMENT OF CONCRETE WORK. EXTERIOR BASEMENT WALLS AND RETAINING WALLS SHALL HAVE VERTICAL CONTROL JOINTS SPACED NOT FARTHER THAN 30'-0" ON CENTER. CONSTRUCTION JOINTS SHALL BE LOCATED TO COINCIDE WITH CONTROL JOINT LOCATIONS.
- CLEAN AND MOISTEN ALL CONSTRUCTION JOINTS IMMEDIATELY PRIOR TO PLACING FRESH CONCRETE.
- UNLESS NOTED OTHERWISE, PROVIDE DOWELS TO MATCH MAIN REINFORCEMENT SIZE AND SPACING. PROVIDE TENSION LAP SPlice UNLESS NOTED OTHERWISE.
- REFER TO THE ARCHITECTURAL, MECHANICAL, ELECTRICAL, AND PLUMBING DRAWINGS FOR CURBS, PADS, DEPRESSIONS, WALL/SLAB OPENINGS, REVEALS, REGLETS, DRIPS, SPECIAL FLOOR FINISHES, AND OTHER REQUIREMENTS NOT SHOWN ON STRUCTURAL DRAWINGS.
- ALUMINUM CONDUIT SHALL NOT BE EMBEDDED IN CONCRETE.
- DO NOT CAST OPENINGS OTHER THAN INDICATED ON THE REVIEWED SHOP DRAWINGS WITHOUT WRITTEN CONSENT OF EOR. DO NOT CORE HOLES IN COLUMNS, BEAMS, JOISTS, WALLS, OR STRUCTURAL CONCRETE SLABS WITHOUT WRITTEN CONSENT OF THE EOR.
- REFER TO ACI 305 FOR REQUIREMENTS FOR PLACING CONCRETE IN HOT WEATHER AND TO ACI 306 FOR REQUIREMENTS FOR PLACING CONCRETE IN COLD WEATHER.

SLAB ON GRADE NOTES

- PREPARE SUBGRADE AS INDICATED IN SOIL REPORT. AT A MINIMUM, PROOF ROLL AND REMOVE ALL SOFT AREAS AND REPLACE WITH COMPATIBLE FILL.
- CONTRACTION JOINT LOCATIONS INDICATED ON SLAB ON GRADE PLAN ARE A SUGGESTED PATTERN INTENDED TO AID THE CONTRACTOR, AND DO NOT IMPLY ANY WARRANTY AGAINST THE OCCURANCE OF SHRINKAGE CRACKS. SAW TO A DEPTH OF AT LEAST 1/4 THE SLAB THICKNESS. START SAWCUTTING WITH EARLY ENTRY SAW AS SOON AS THE CONCRETE WILL SUPPORT THE WEIGHT OF THE SAW AND OPERATOR AND NOT RAVEL EDGES OR DISLodge AGGREGATE, BUT IN NO CASE MORE THAN 6 HOURS AFTER THE SLAB IS PLACED.
- SEE ARCHITECTURAL DRAWINGS FOR LOCATIONS AND SIZES OF SLAB DEPRESSIONS.
- SLAB ON GRADE REQUIRES FIBER REINFORCING. SEE SPECIFICATIONS FOR APPROVED MANUFACTURERS AND MINIMUM QUANTITIES.
- SLAB ON GRADE THICKNESS, ELEVATION, FLATNESS, LEVELNESS TOLERANCES:
THICKNESS: PLUS 1/2 INCHES; MINUS 0 INCHES
- WET CURE SLAB UNLESS NOTED OTHERWISE ON DRAWINGS.
- SLAB SURFACE FINISH TO BE APPROVED PRIOR TO PLACEMENT.



**DANE COUNTY
COLISEUM LOADING
DOCKS**

1919 Alliant Energy Center Way,
Madison, WI 53713

DATE OF ISSUE: 2/4/2016

REVISIONS:

PROJECT # 15019
REQUEST FOR BID # 316001

**STRUCTURAL
GENERAL NOTES**

S002



**DANE COUNTY
COLISEUM LOADING
DOCKS**

1919 Alliant Energy Center Way,
Madison, WI 53713



FOUNDATION PLAN NOTES

- SEE SHEET S001 AND S002 FOR STRUCTURAL GENERAL NOTES.
- VERIFY ALL DIMENSIONS WITH ARCHITECTURAL DRAWINGS.
- TOP OF FOUNDATION WALL ELEVATION AS INDICATED ON PLAN
- PROVIDE CORNER REINFORCEMENT AT ALL WALL INTERSECTIONS PER DETAIL 2
S304
- SEE SHEET S001 AND DETAIL 4
S304 FOR SLAB ON GRADE JOINT INFORMATION.
- REINFORCEMENT IN SPREAD FOOTINGS SHALL CONFORM TO DETAIL 1
S304
- FOOTING STEPS SHALL BE PER DETAIL 1
S304
- SLAB REINFORCEMENT: #4 EPOXY COATED BARS 12" O.C EACH WAY, TOP
- FIELD VERIFY ALL DOCK LEVELER DEPRESSION DIMENSIONS WITH MANUFACTURER.
- CHAMFER ALL EXPOSED EDGES 3/4"

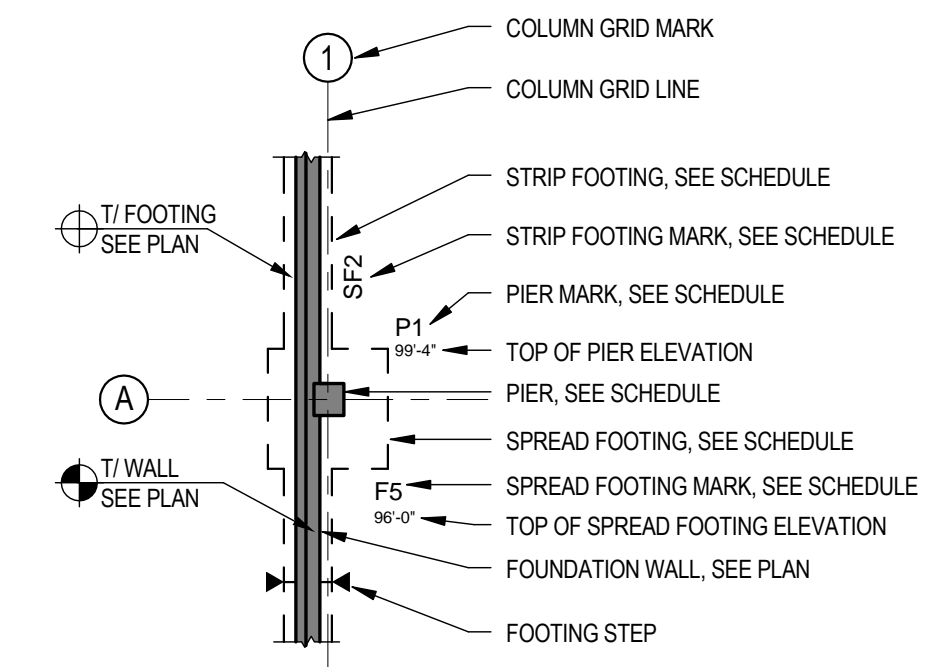

FOUNDATION LEGEND

KEY NOTES:
A THESE WALLS AND FOOTINGS TO BE OMITTED WITH
SLAB ON GRADE CONSTRUCTION ALTERNATE

1 FOUNDATION PLAN
1/8" = 1'-0"

FOOTING SCHEDULE					
MARK	LENGTH	WIDTH	THICKNESS	BOTTOM REINFORCEMENT	TOP REINFORCEMENT
F1	5'-0"	5'-0"	1'-6"	(7) #6 BARS EACH WAY	NONE
F2	5'-6"	5'-6"	2'-0"	(9) #6 BARS EACH WAY	NONE
F3	6'-6"	6'-6"	1'-6"	(9) #6 BARS EACH WAY	NONE
F4	9'-0"	4'-0"	1'-6"	(9) #6 BARS EACH WAY	NONE

DATE OF ISSUE: 2/4/2016

REVISIONS:

PROJECT # 15019
REQUEST FOR BID # 316001

FOUNDATION PLAN

S101

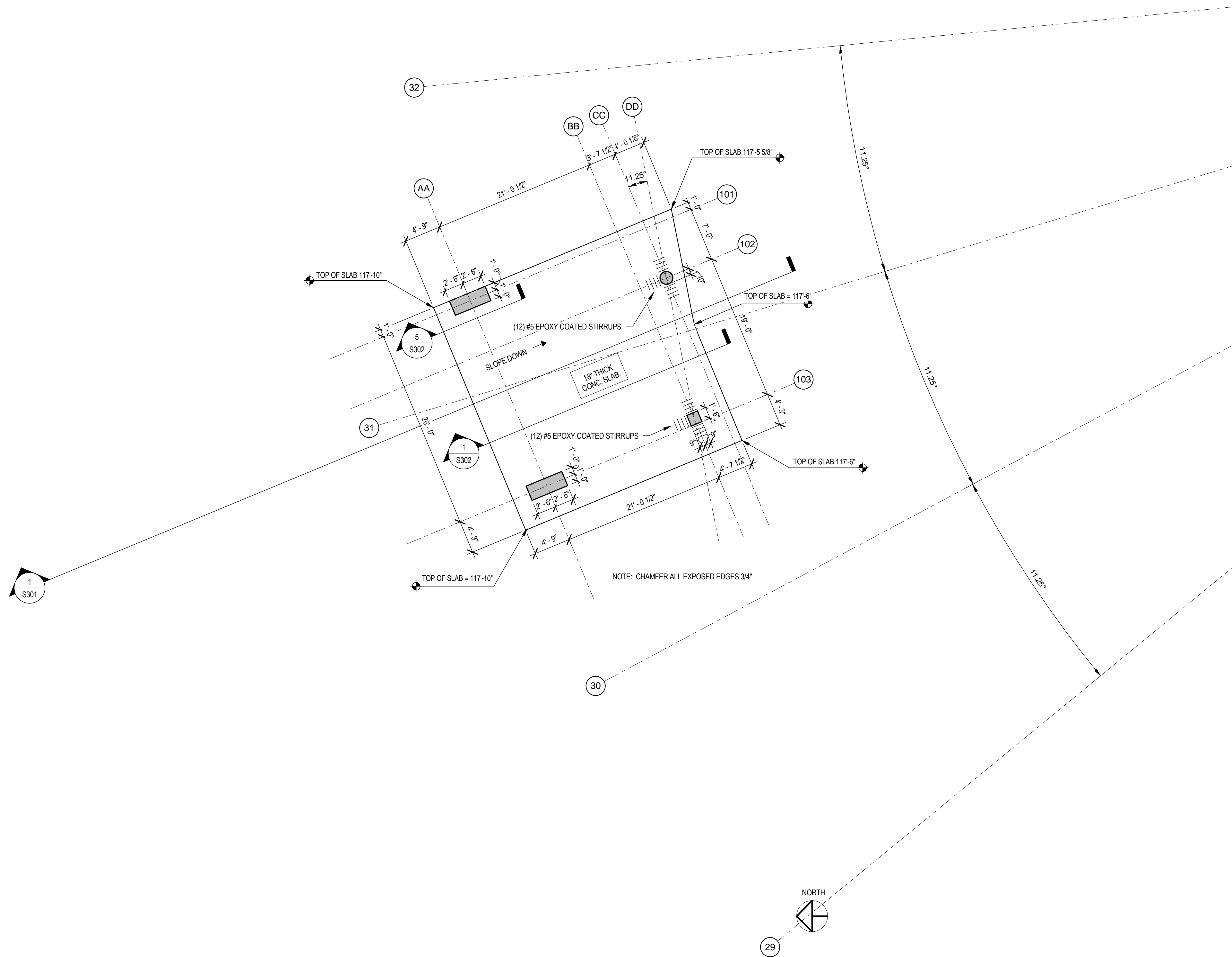

2 ROOF FRAMING PLAN
1/8" = 1'-0"



**DANE COUNTY
COLISEUM LOADING
DOCKS**

1919 Alliant Energy Center Way,
Madison, WI 53713

DATE OF ISSUE: 2/4/2016

REVISIONS:	

PROJECT # 15019
REQUEST FOR BID # 316001

**ROOF FRAMING
PLAN**

S201



**DANE COUNTY
 COLISEUM LOADING
 DOCKS**

1919 Alliant Energy Center Way,
 Madison, WI 53713

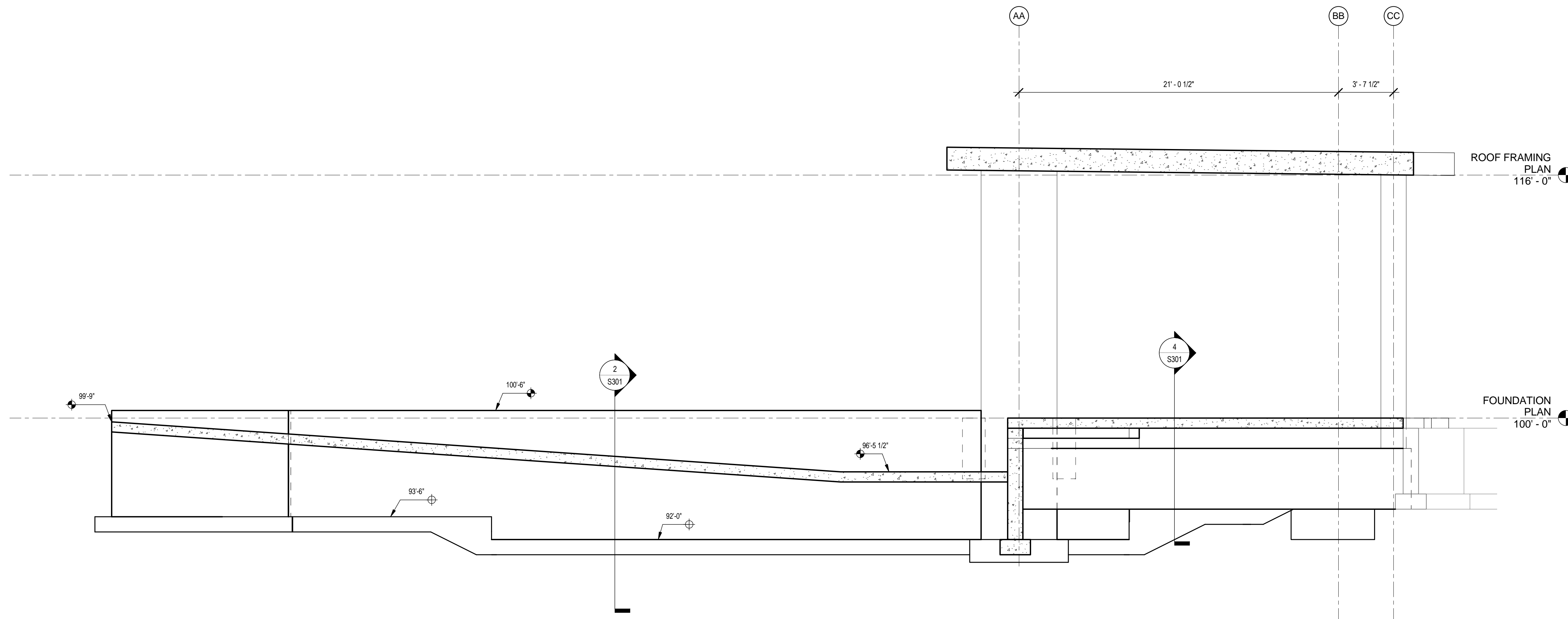

1 LOADING DOCK SECTION
 1/4" = 1'-0"

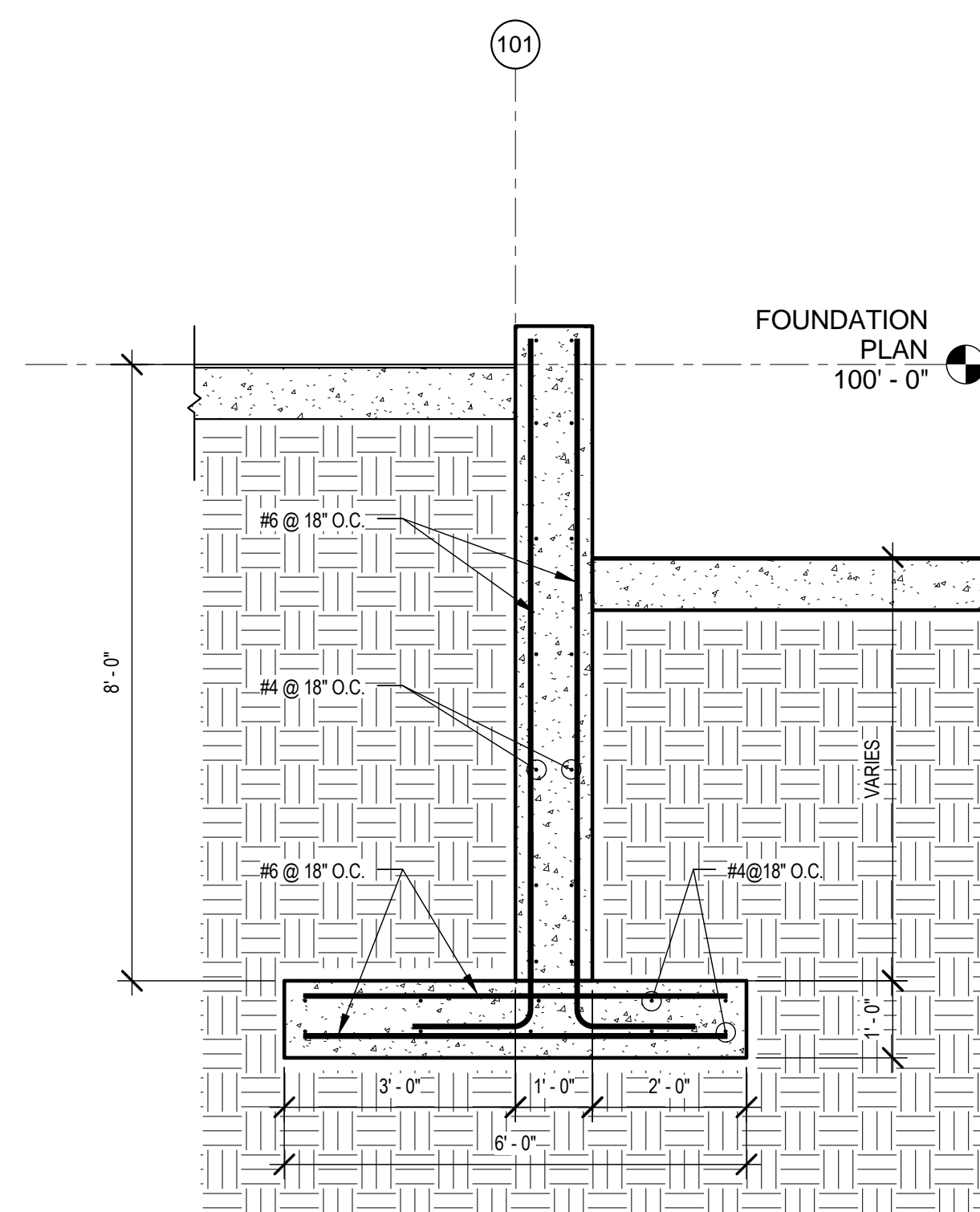

2 RETAINING WALL SECTION
 1/2" = 1'-0"

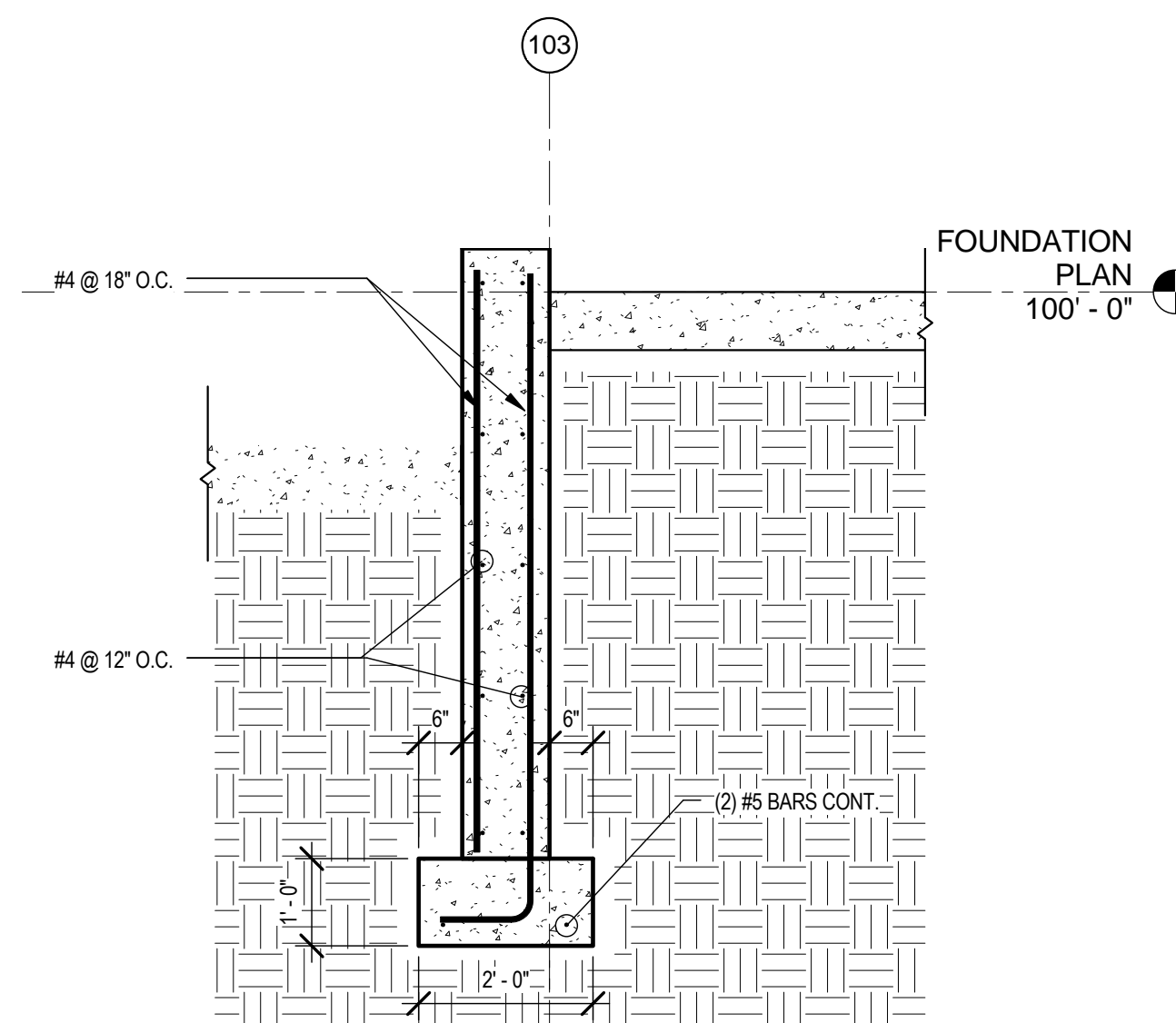

3 SECTION AT RETAINING WALL
 1/2" = 1'-0"

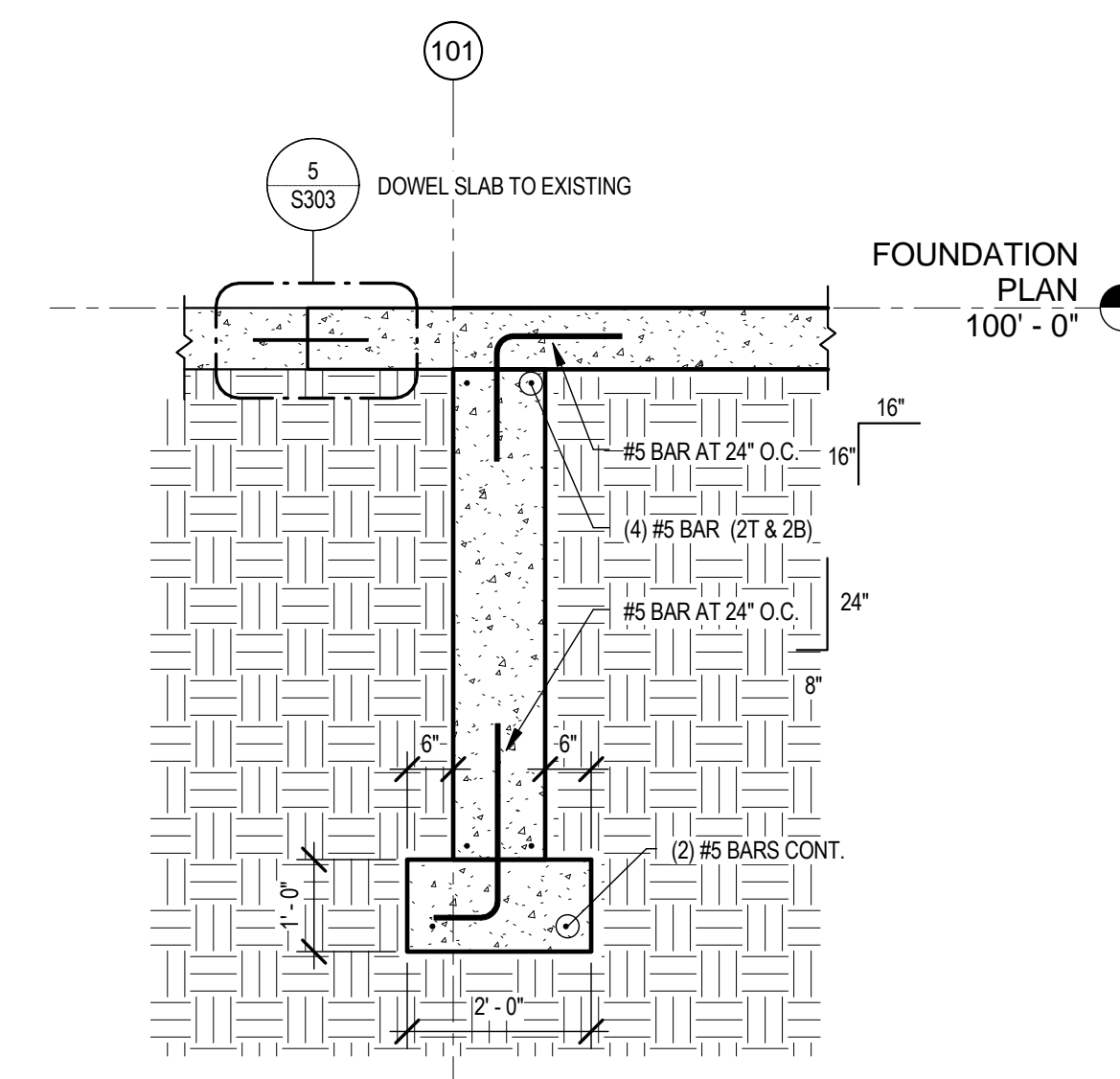

4 FOUNDATION WALL SECTION
 1/2" = 1'-0"

DATE OF ISSUE: 2/4/2016

REVISIONS:

PROJECT # 15019
 REQUEST FOR BID # 316001

**STRUCTURAL
 DETAILS**

S301



**DANE COUNTY
COLISEUM LOADING
DOCKS**

1919 Alliant Energy Center Way,
Madison, WI 53713

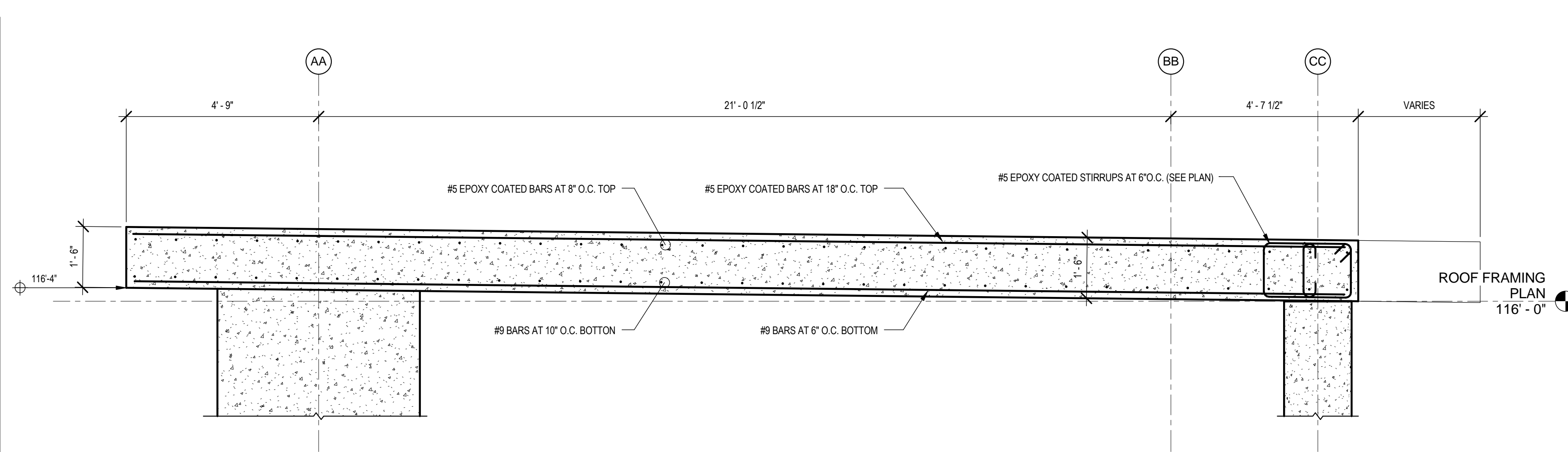

1 LOADING DOCK ROOF SECTION
1/2" = 1'-0"

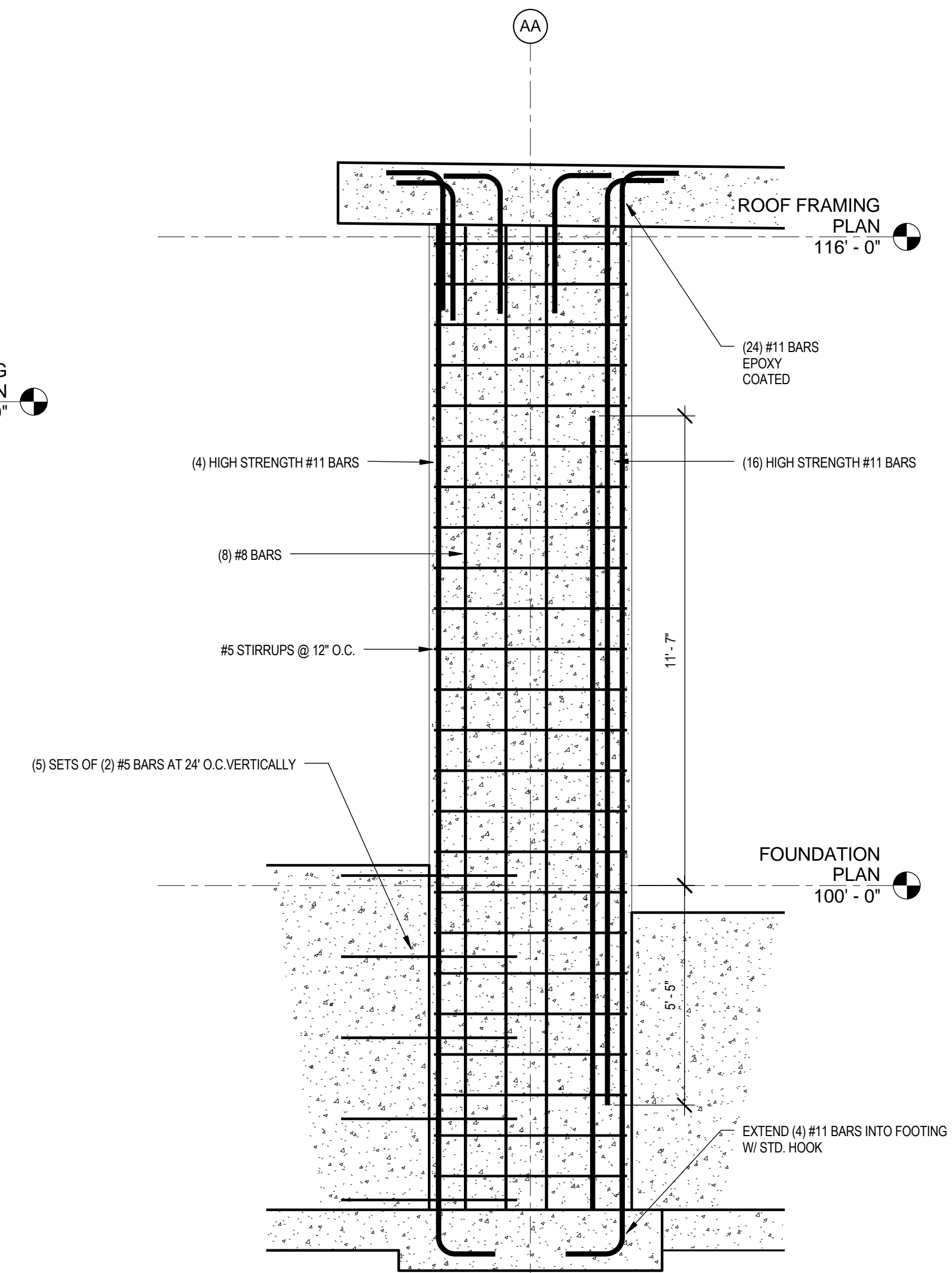

5 COLUMN ELEVATION
3/8" = 1'-0"

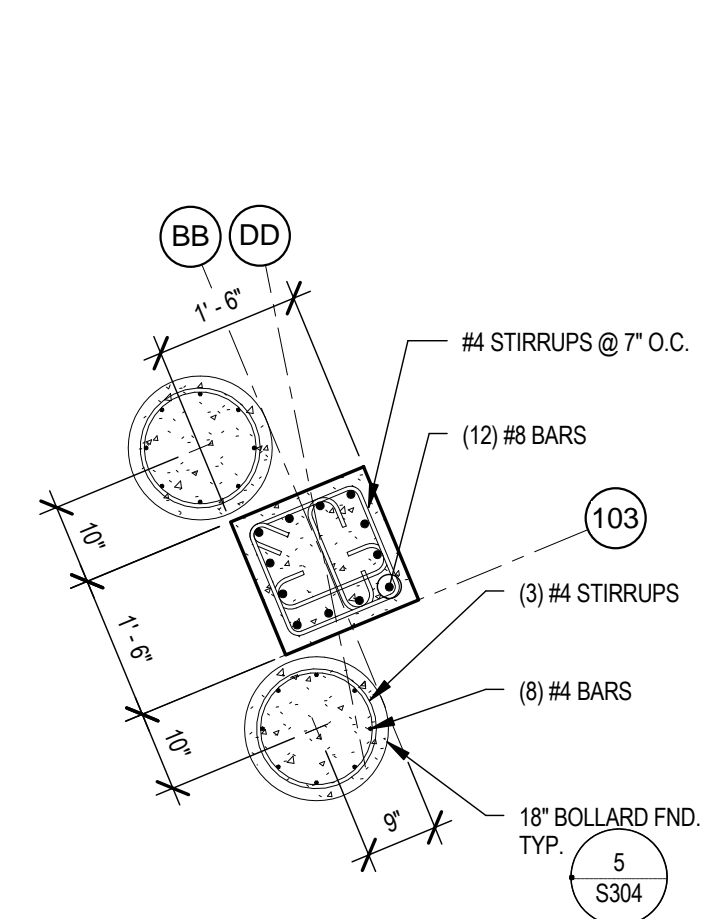

2 COLUMN SECTION
1/2" = 1'-0"

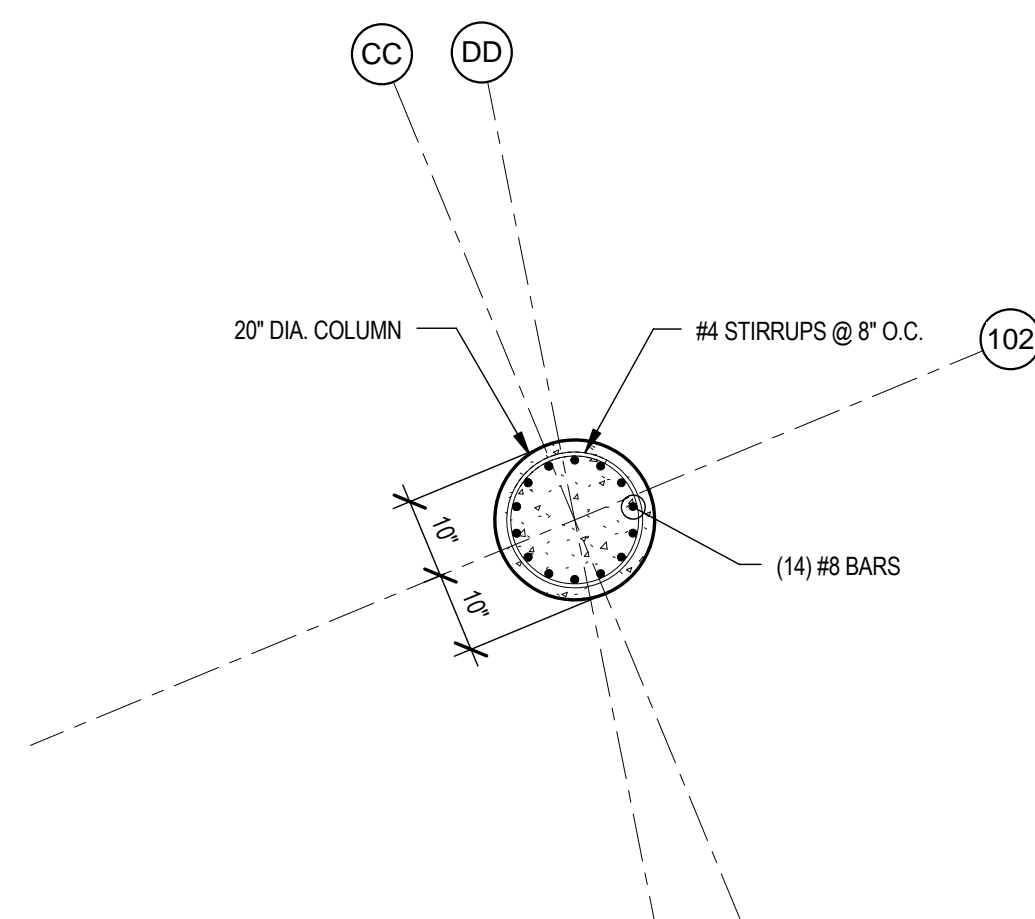

3 COLUMN SECTION
1/2" = 1'-0"

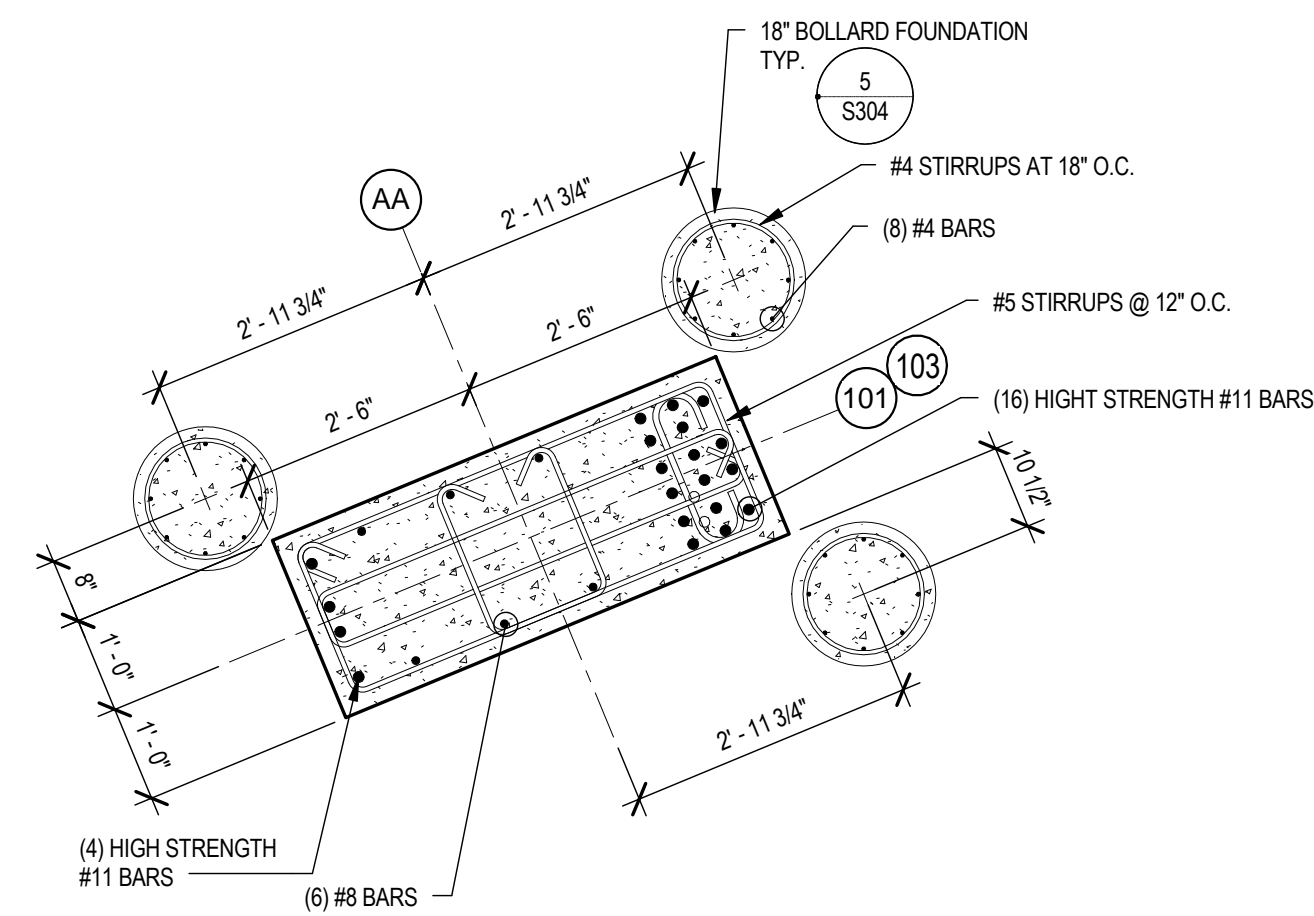

4 COLUMN SECTION
1/2" = 1'-0"

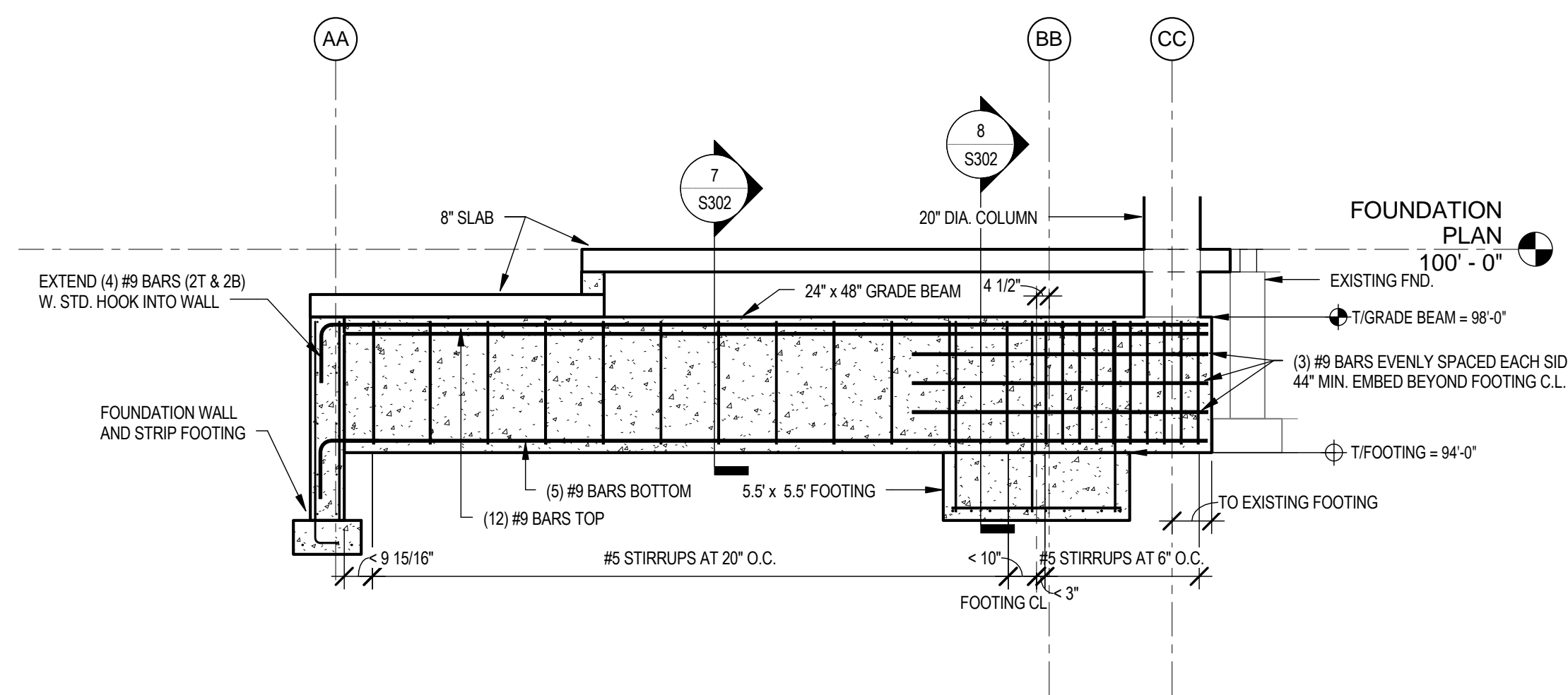

6 GRADE BEAM ELEVATION
1/4" = 1'-0"

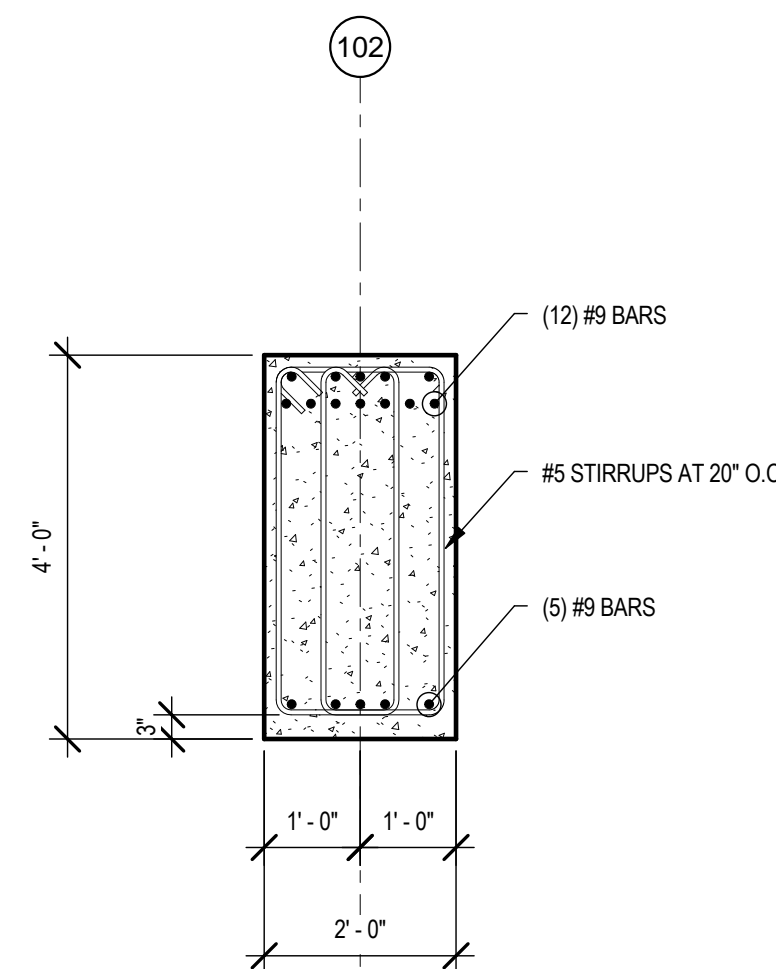

7 GRADE BEAM SECTION
1/2" = 1'-0"

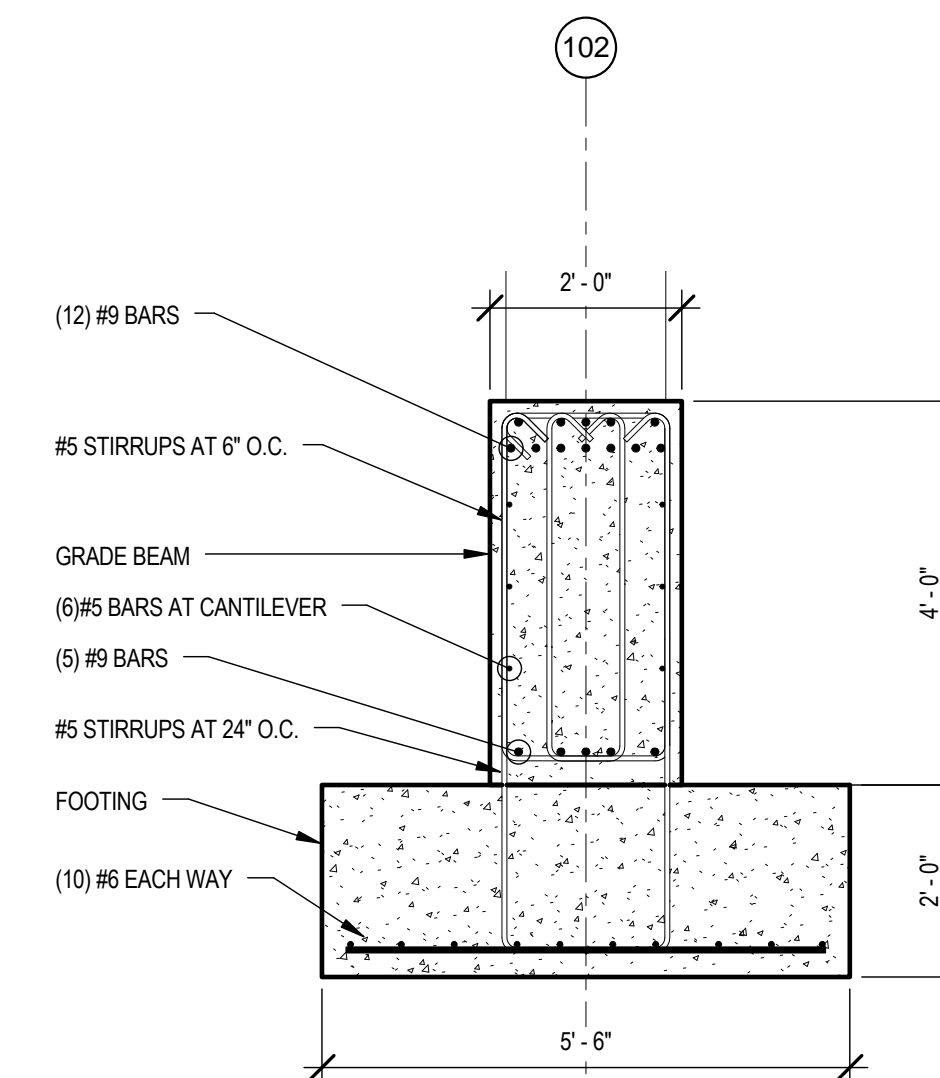

8 FOOTING/GRADE BEAM SECTION
1/2" = 1'-0"

DATE OF ISSUE: 2/4/2016

REVISIONS:	

PROJECT # 15019
REQUEST FOR BID # 316001

**STRUCTURAL
DETAILS**

S302



**DANE COUNTY
COLISEUM LOADING
DOCKS**

1919 Alliant Energy Center Way,
Madison, WI 53713

DATE OF ISSUE: 2/4/2016

REVISIONS:	

PROJECT # 15019
REQUEST FOR BID # 316001

**STRUCTURAL
DETAILS**

S303

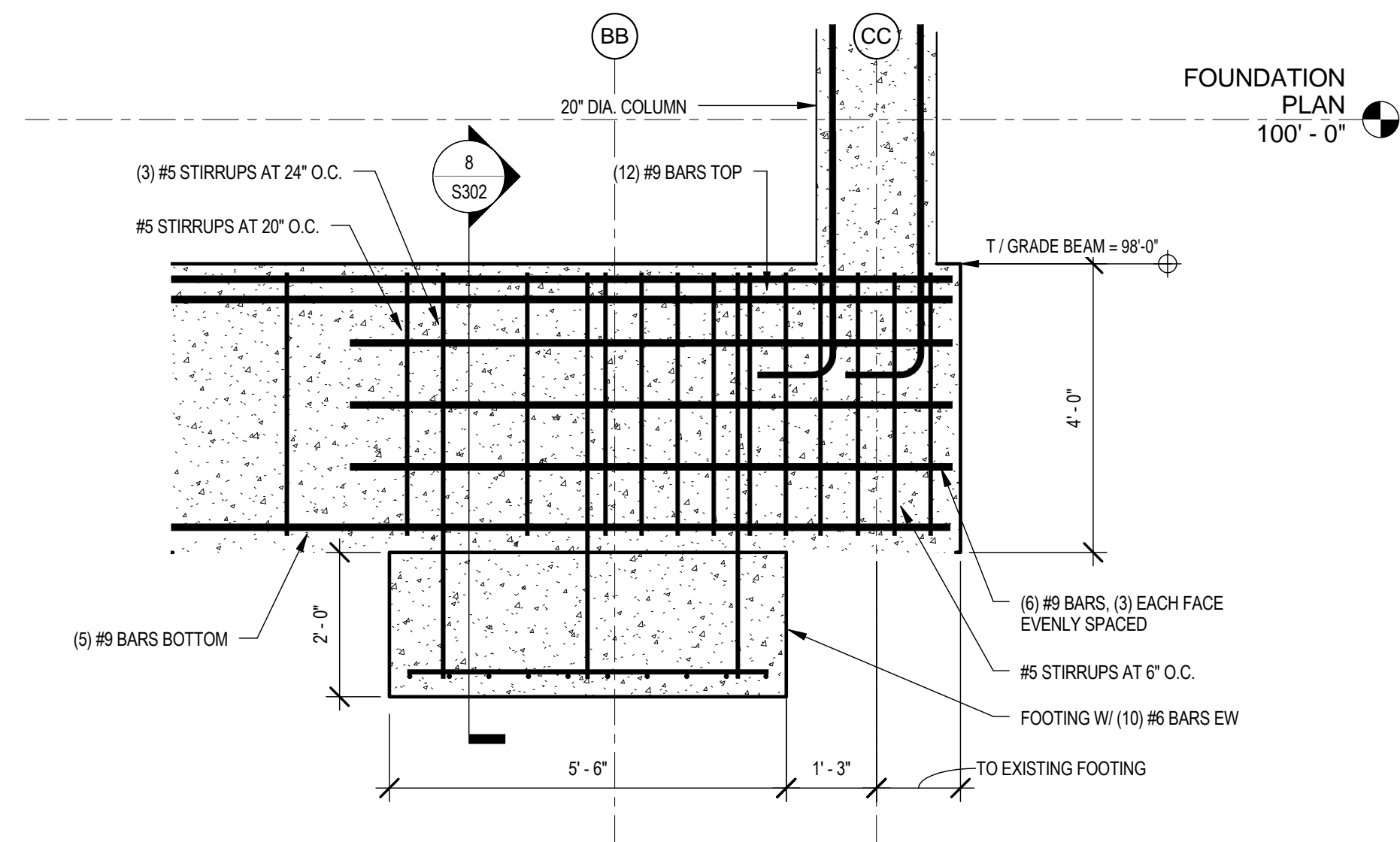

1 FOOTING/GRADE BEAM ELEVATION
1/2" = 1'-0"

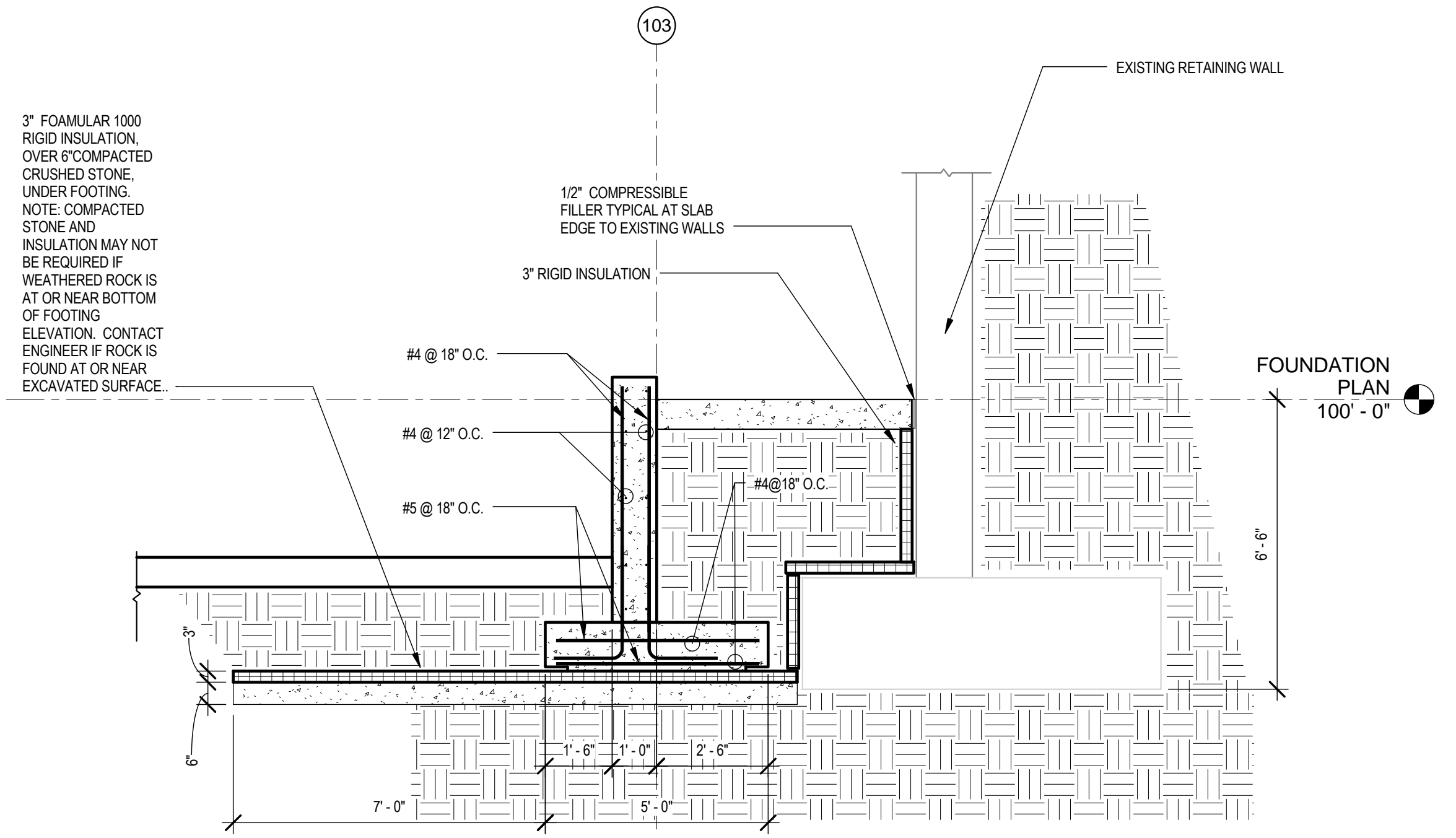

2 SECTION AT RETAINING WALL
3/8" = 1'-0"

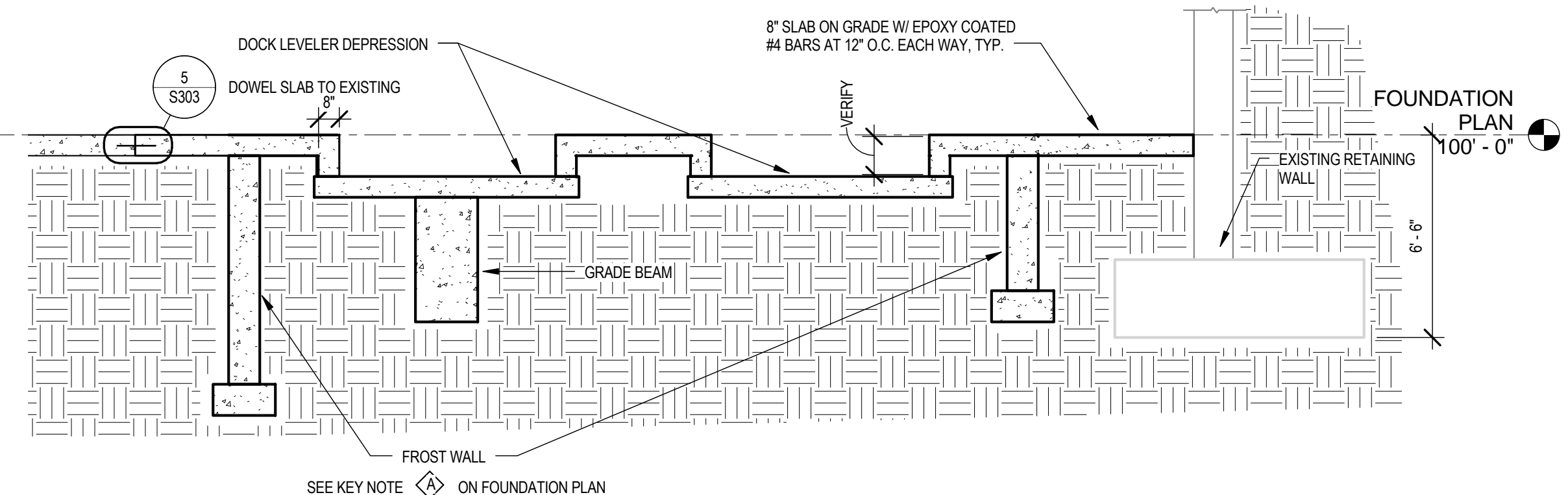

3 SECTION AT DOCK LEVELER
1/4" = 1'-0"

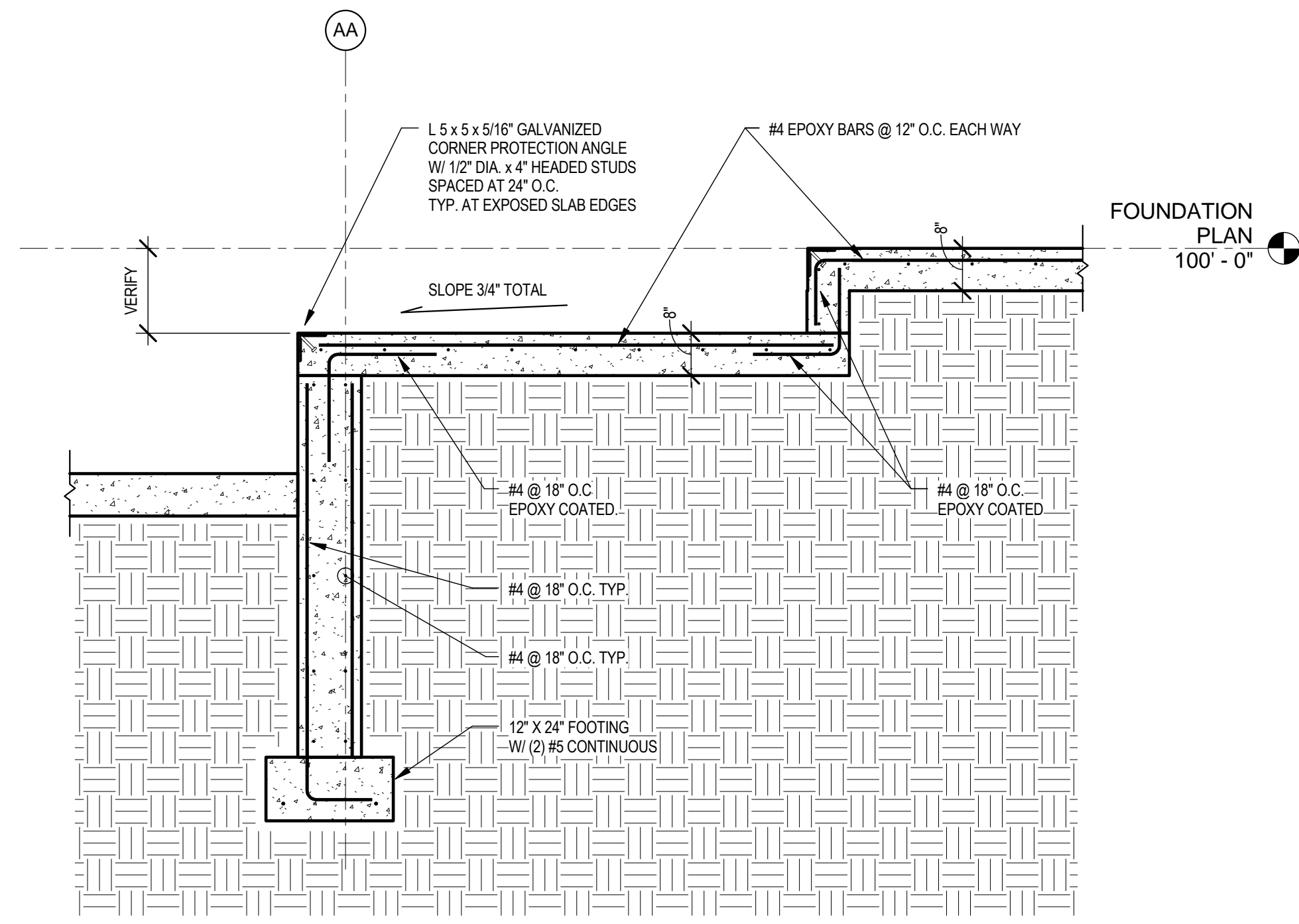

4 DOCK LEVELER SECTION
1/2" = 1'-0"

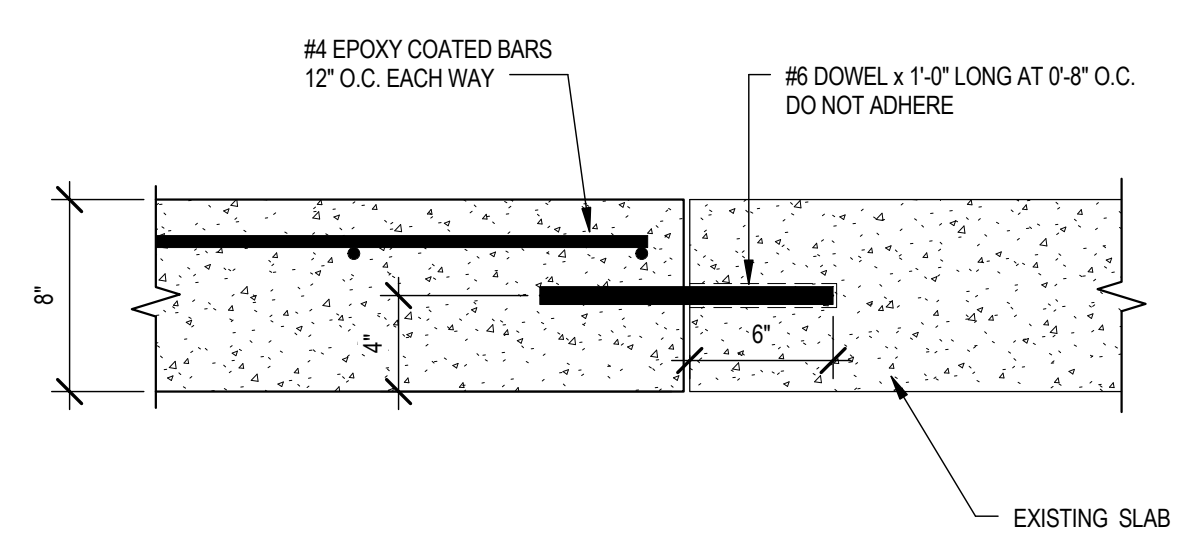

5 DOWELED SLAB
1 1/2" = 1'-0"

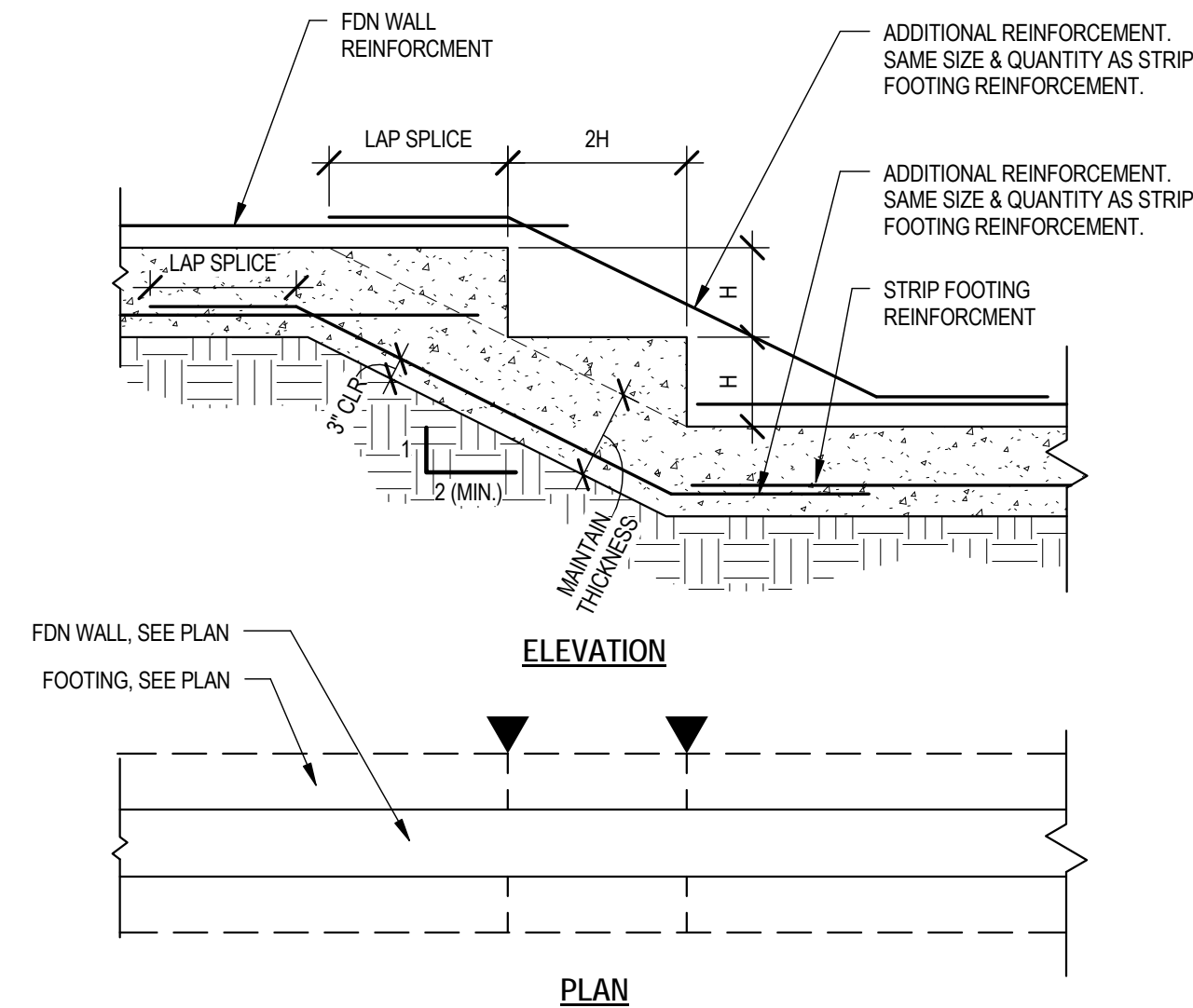

1 FTG STEP DETAIL
1/2" = 1'-0"

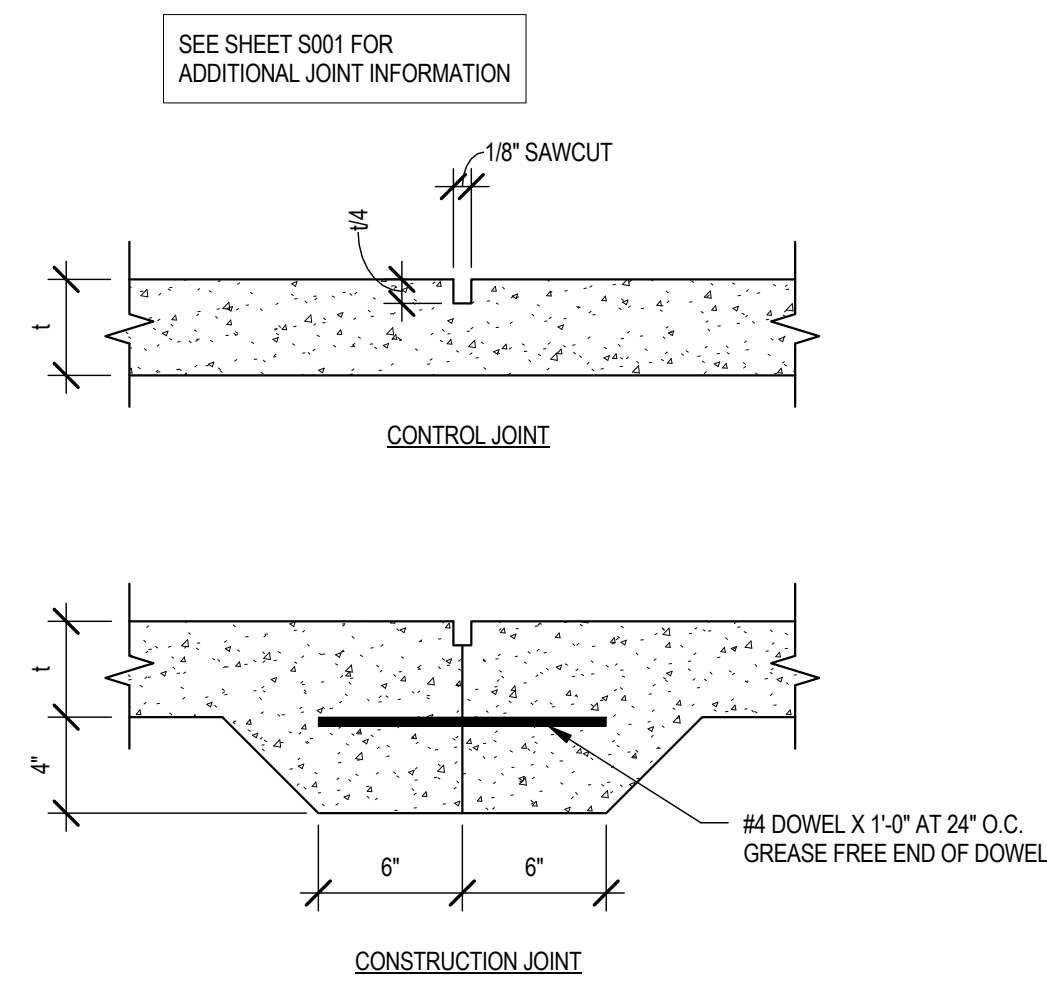

4 TYP SLAB JOINTS
1 1/2" = 1'-0"

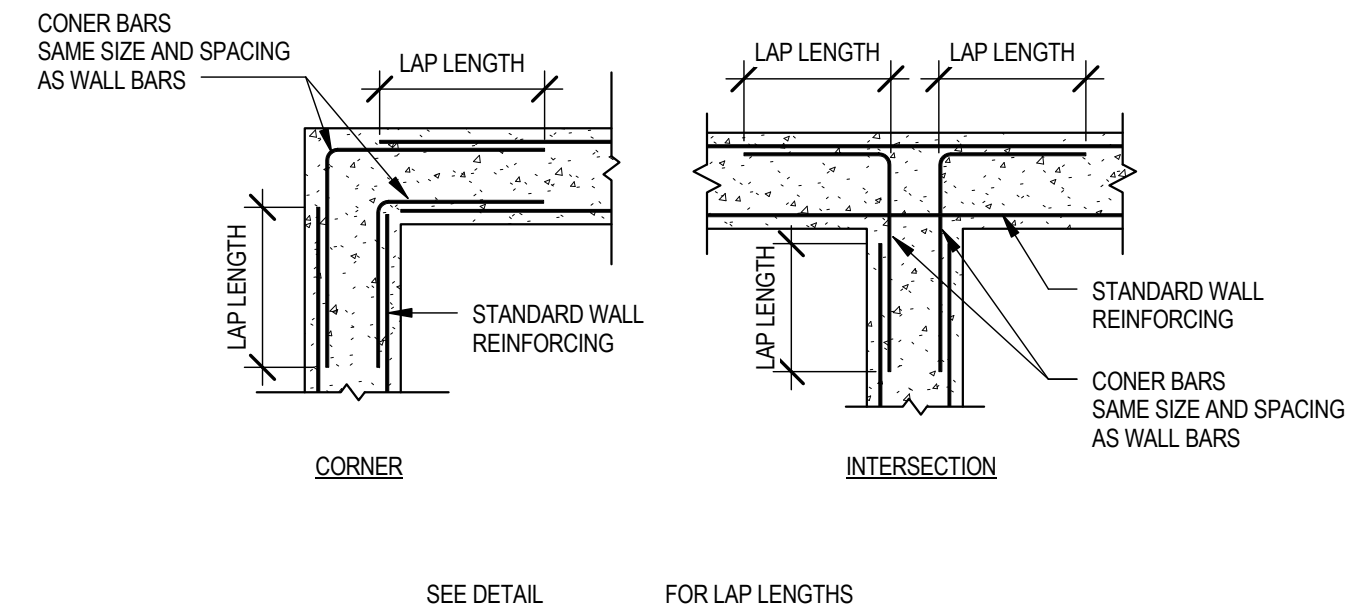

2 CORNER REINFORCEMENT
1/2" = 1'-0"

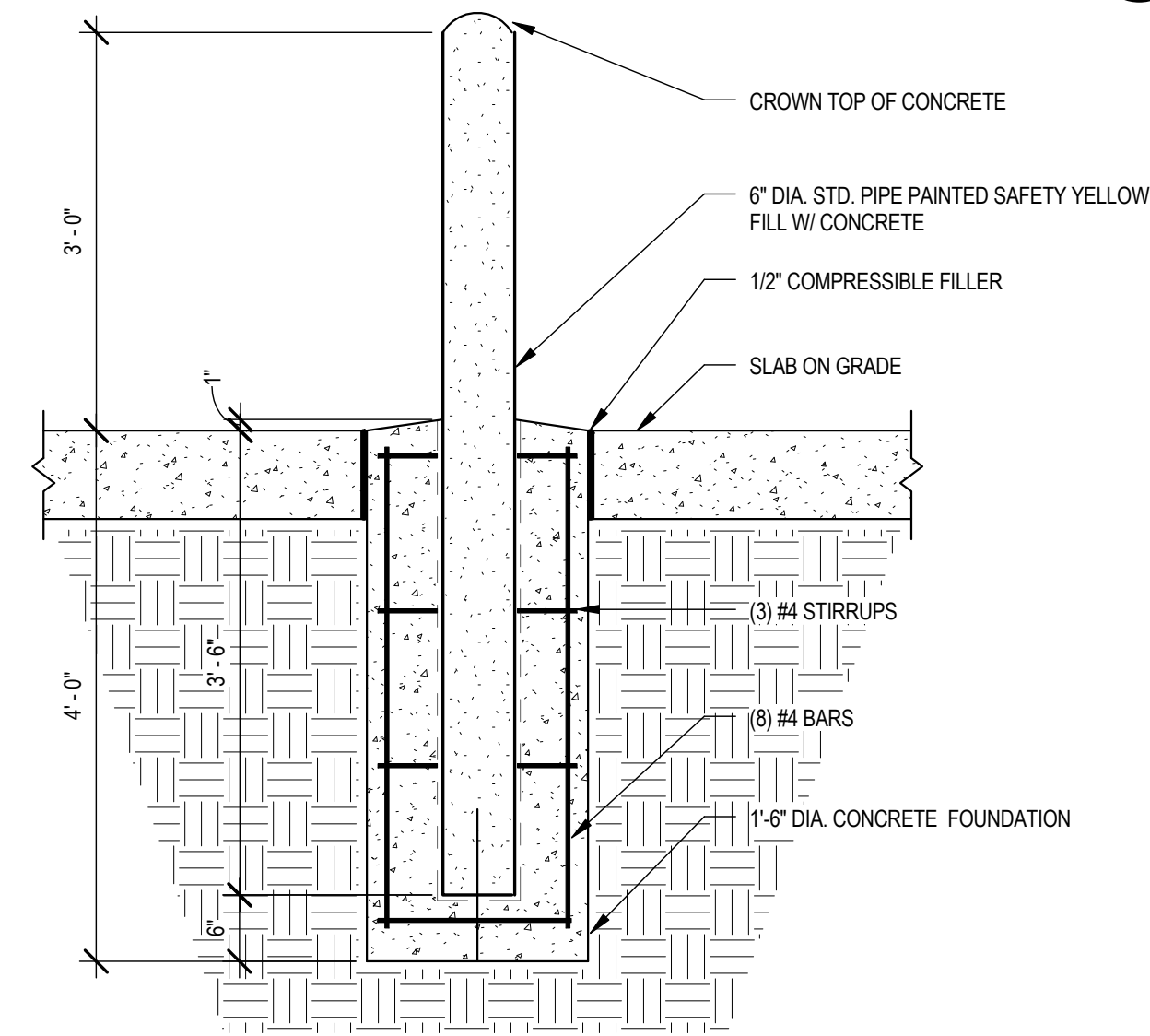

5 PIPE BOLLARD
3/4" = 1'-0"

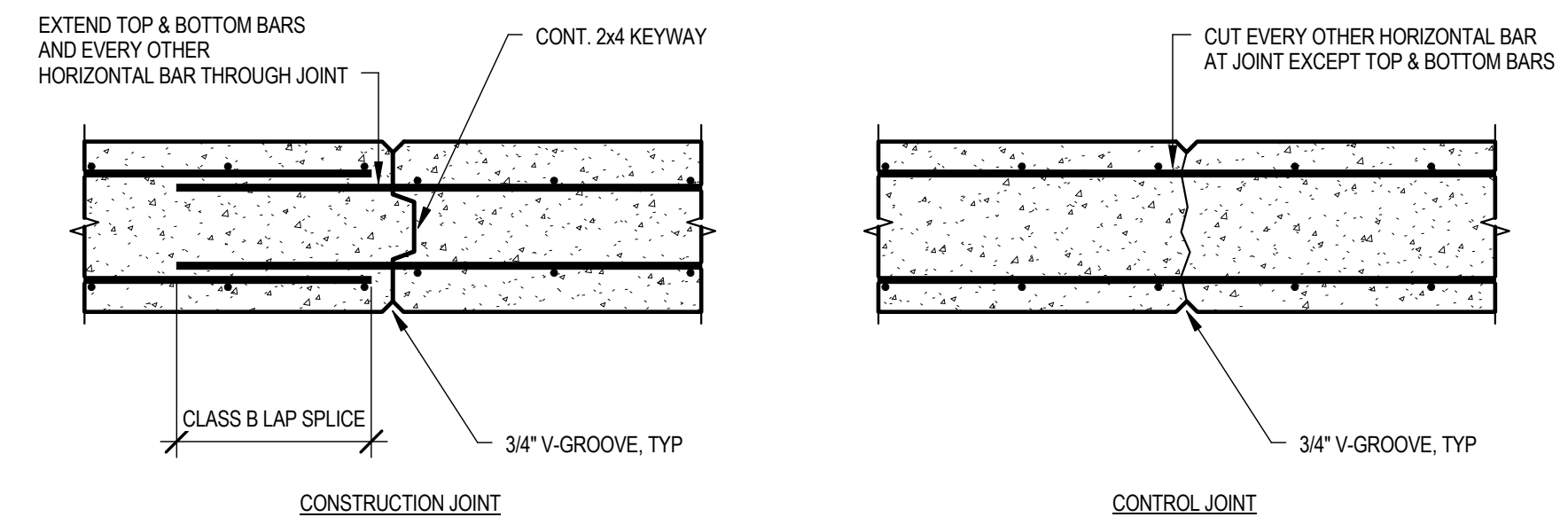

3 TYPICAL VERTICAL WALL JOINTS
1" = 1'-0"

NOTES: 1. WEAKENED PLANE CONTROL JOINTS SHOULD OCCUR AT INTERVALS OF 25 FEET; AND KEYED CONSTRUCTION JOINTS AT EVERY FOURTH JOINT
2. SEE PLAN & ASSOCIATED SECTIONS FOR WALL THICKNESS & REINFORCING.
3. CENTER SINGLE LAYER OF STEEL IN WALL SECTION, UON.

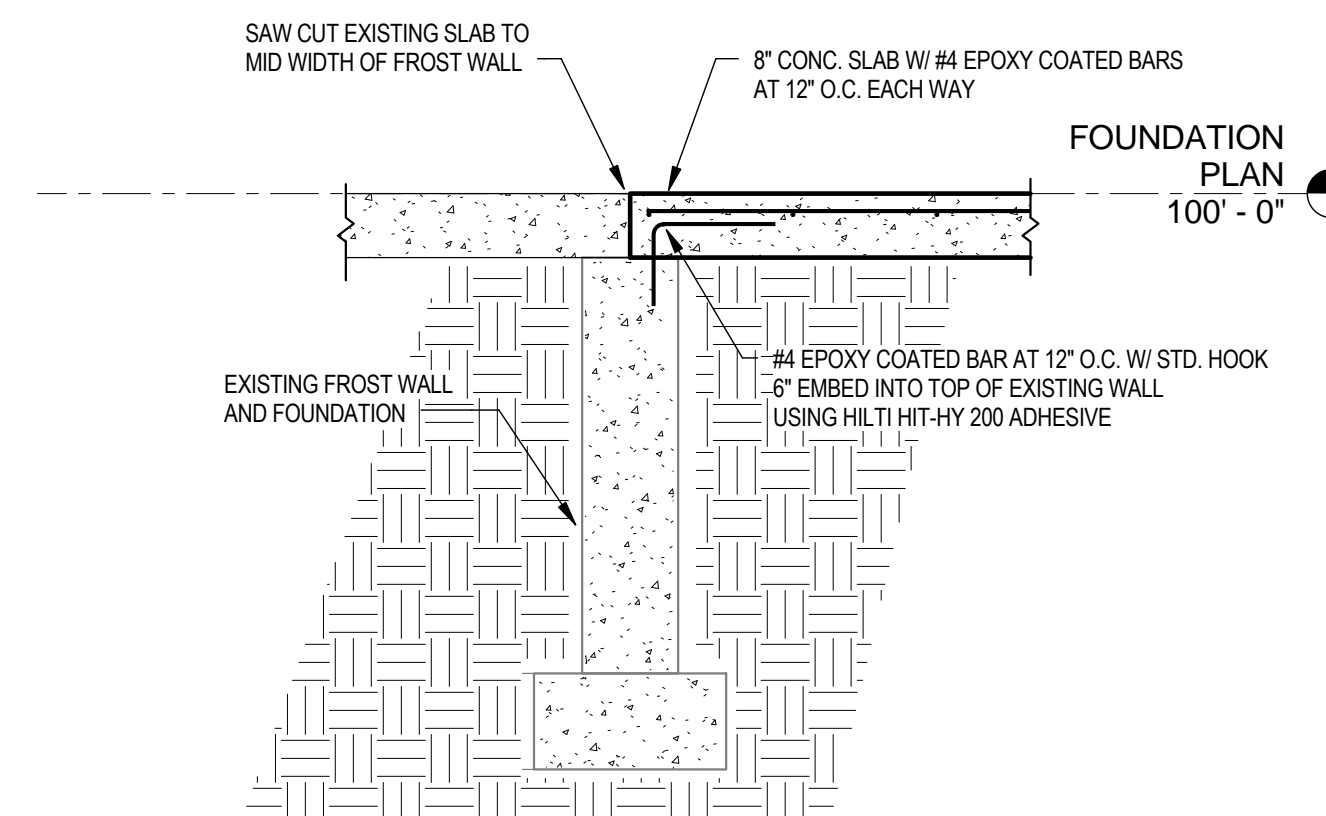

6 SECTION AT EXISTING FROST WALL
1/2" = 1'-0"



**DANE COUNTY
COLISEUM LOADING
DOCKS**

1919 Alliant Energy Center Way,
Madison, WI 53713

DATE OF ISSUE: 2/4/2016

REVISIONS:

PROJECT # 15019
REQUEST FOR BID # 316001

**STRUCTURAL
DETAILS**

S304

FLOOR PLAN GENERAL NOTES

- A. FIELD SURVEYING AND ENGINEERING OF EXISTING AND PROPOSED CONDITIONS IS SOLELY THE RESPONSIBILITY OF THE GENERAL CONTRACTOR.
- B. SEE SITE, ELECTRICAL AND PLUMBING DRAWINGS FOR ADDITIONAL WORK.

COLISEUM LOADING DOCKS - ALLIANT ENERGY CENTER

1919 Alliant Energy Center Way
Madison, WI 53713

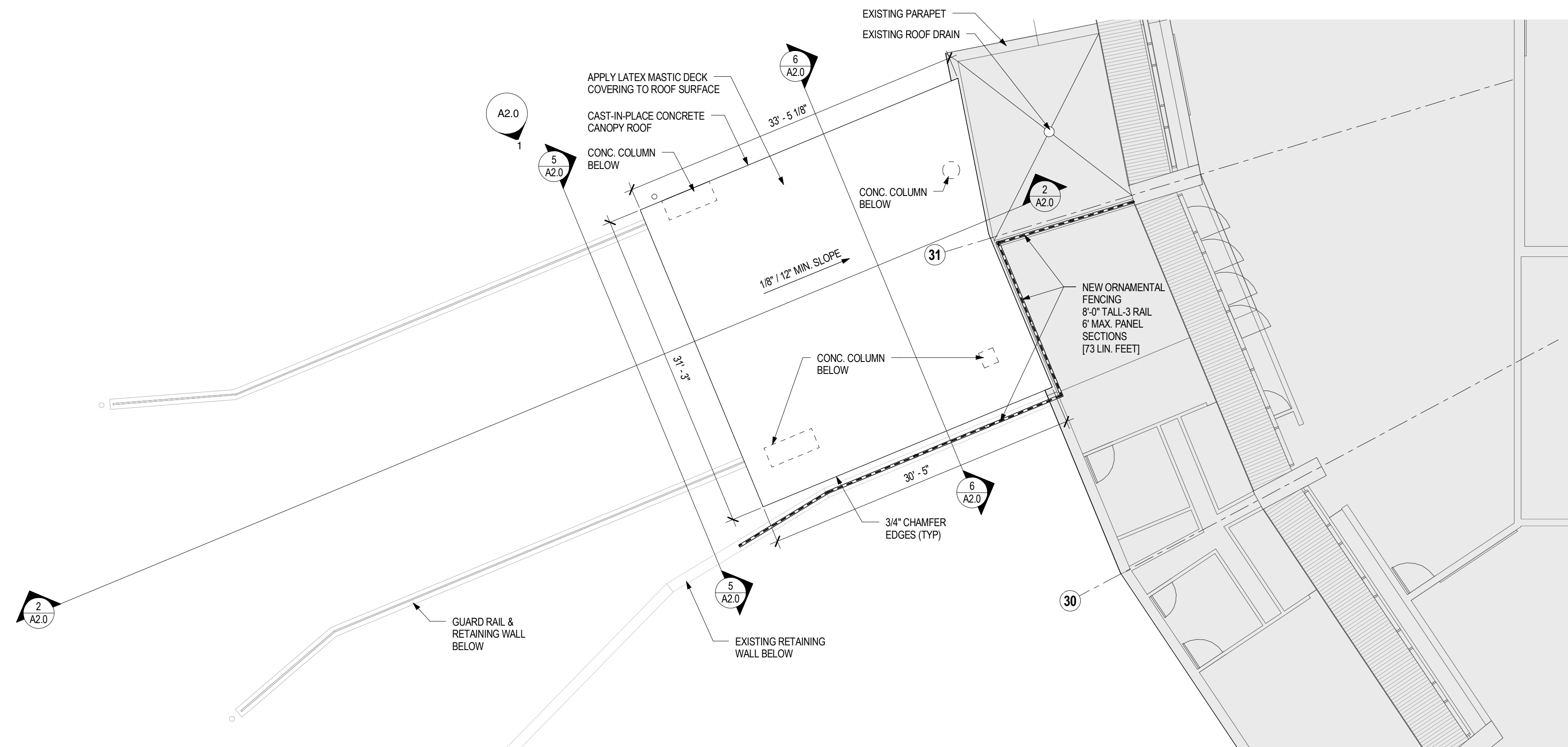

2 ROOF PLAN
1/8" = 1'-0"

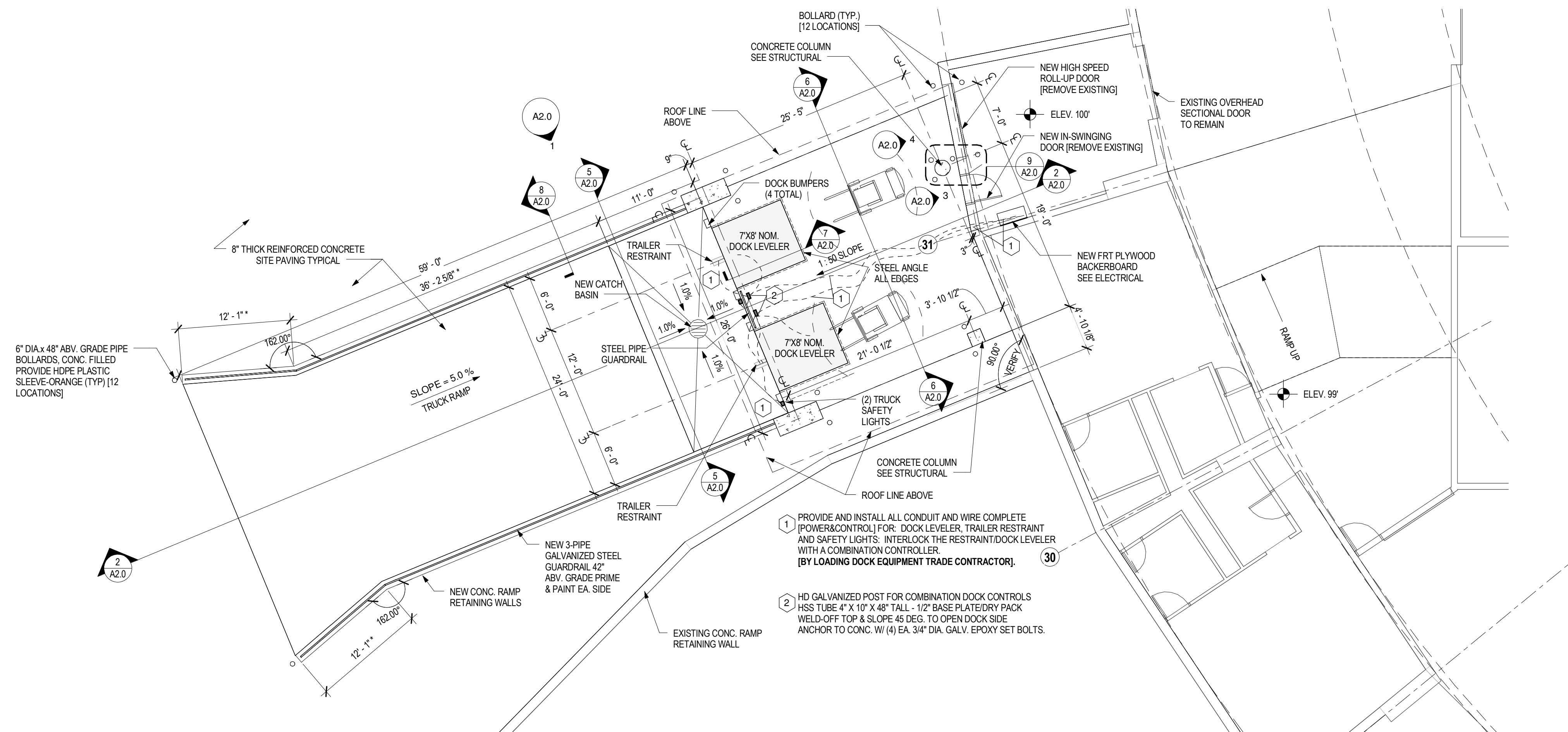

1 FLOOR PLAN
1/8" = 1'-0"

- 1 PROVIDE AND INSTALL ALL CONDUIT AND WIRE COMPLETE [POWER/CONTROL] FOR: DOCK LEVELER, TRAILER RESTRAINT AND SAFETY LIGHTS. INTERLOCK THE RESTRAINT/DOCK LEVELER WITH A COMBINATION CONTROLLER. [BY LOADING DOCK EQUIPMENT TRADE CONTRACTOR].
- 2 HD GALVANIZED POST FOR COMBINATION DOCK CONTROLS HSS TUBE 4" X 10" X 48" TALL - 1/2" BASE PLATE DRY PACK WELD-OFF TOP & SLOPE 45 DEG. TO OPEN DOCK SIDE ANCHOR TO CONC. W/ (4) EA. 3/4" DIA. GALV. EPOXY SET BOLTS.

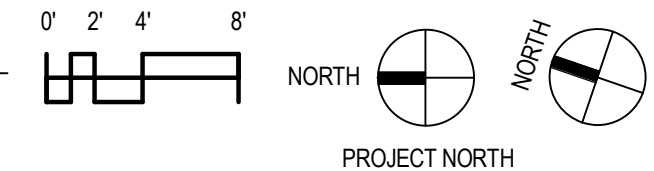

DATE OF ISSUE: 2/4/2016

REVISIONS:

PROJECT # 15019
REQUEST FOR BID # 316001

FLOOR & ROOF PLAN

A1.0

COLISEUM LOADING DOCKS - ALLIANT ENERGY CENTER

1919 Alliant Energy Center Way
Madison, WI 53713

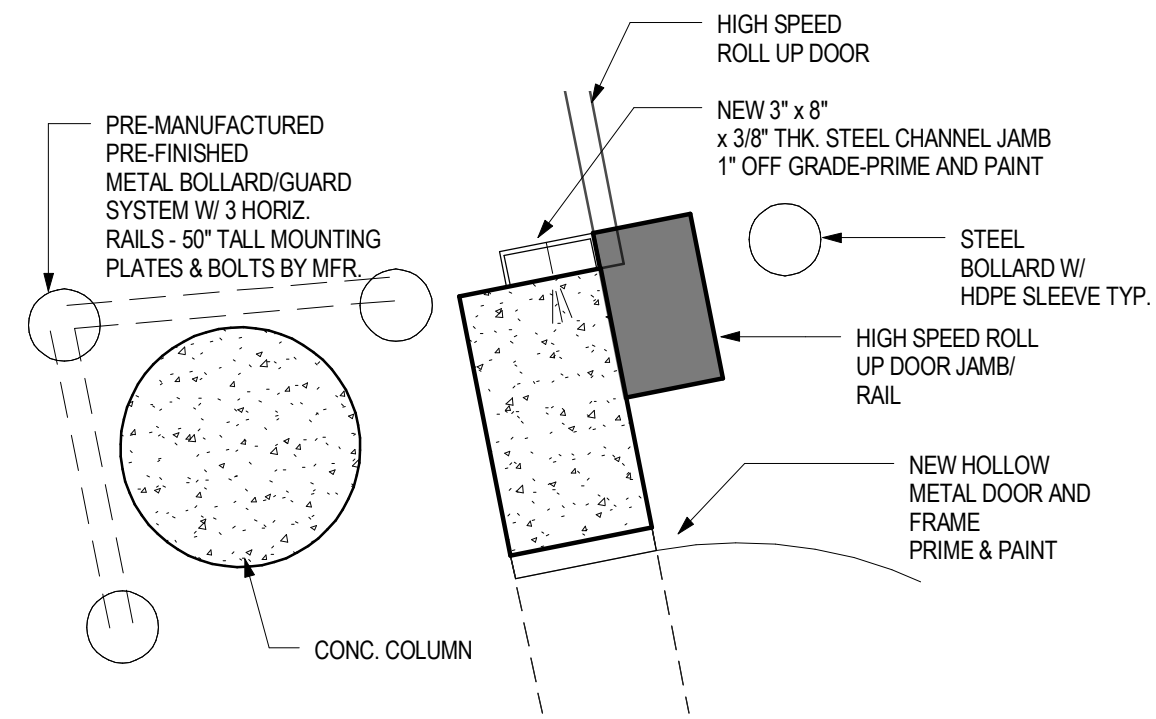

9 BOLLARDS AT ROUND COLUMNS
3/4" = 1'-0"

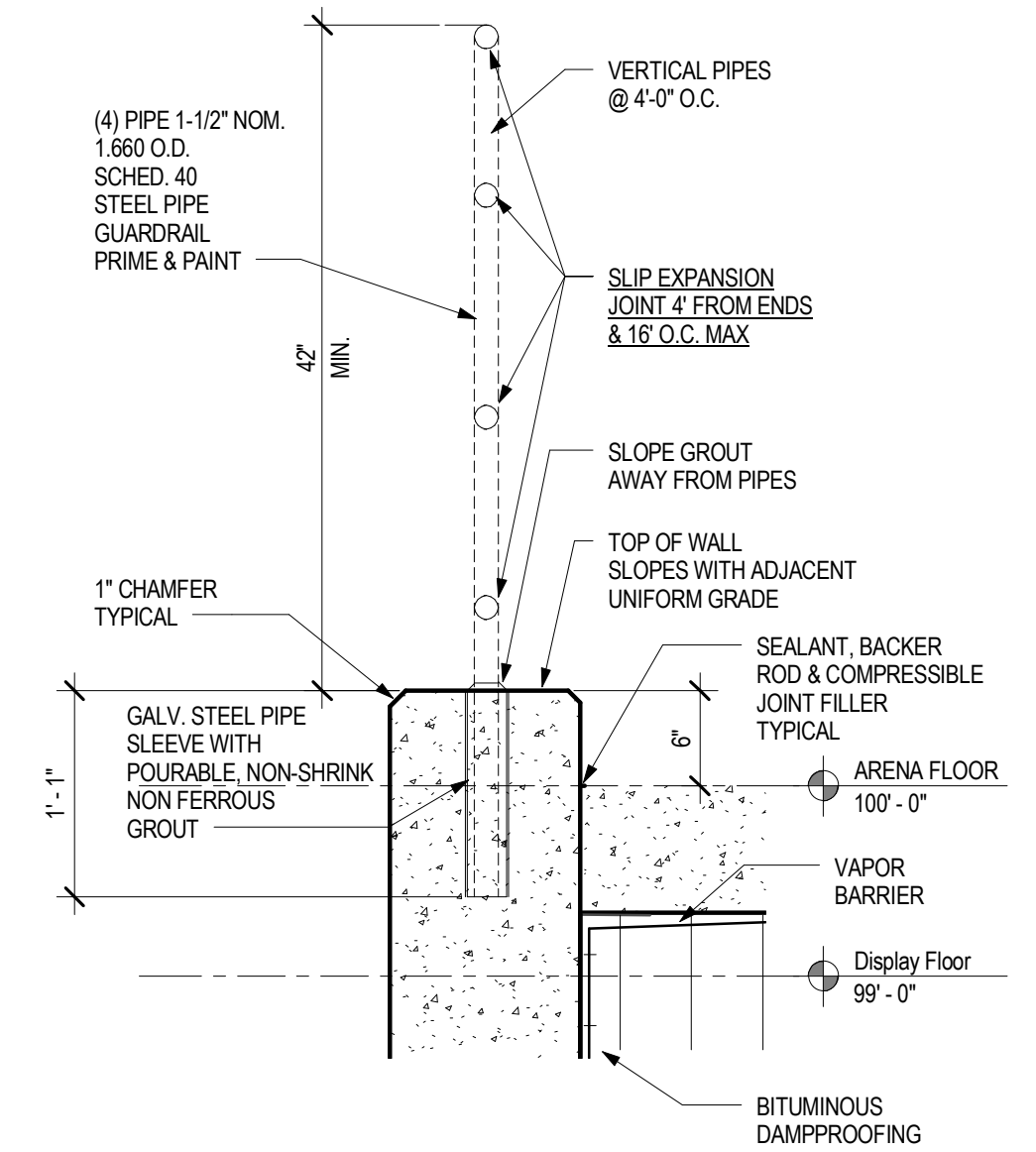

8 RAMP GUARDRAIL DETAIL
1" = 1'-0"

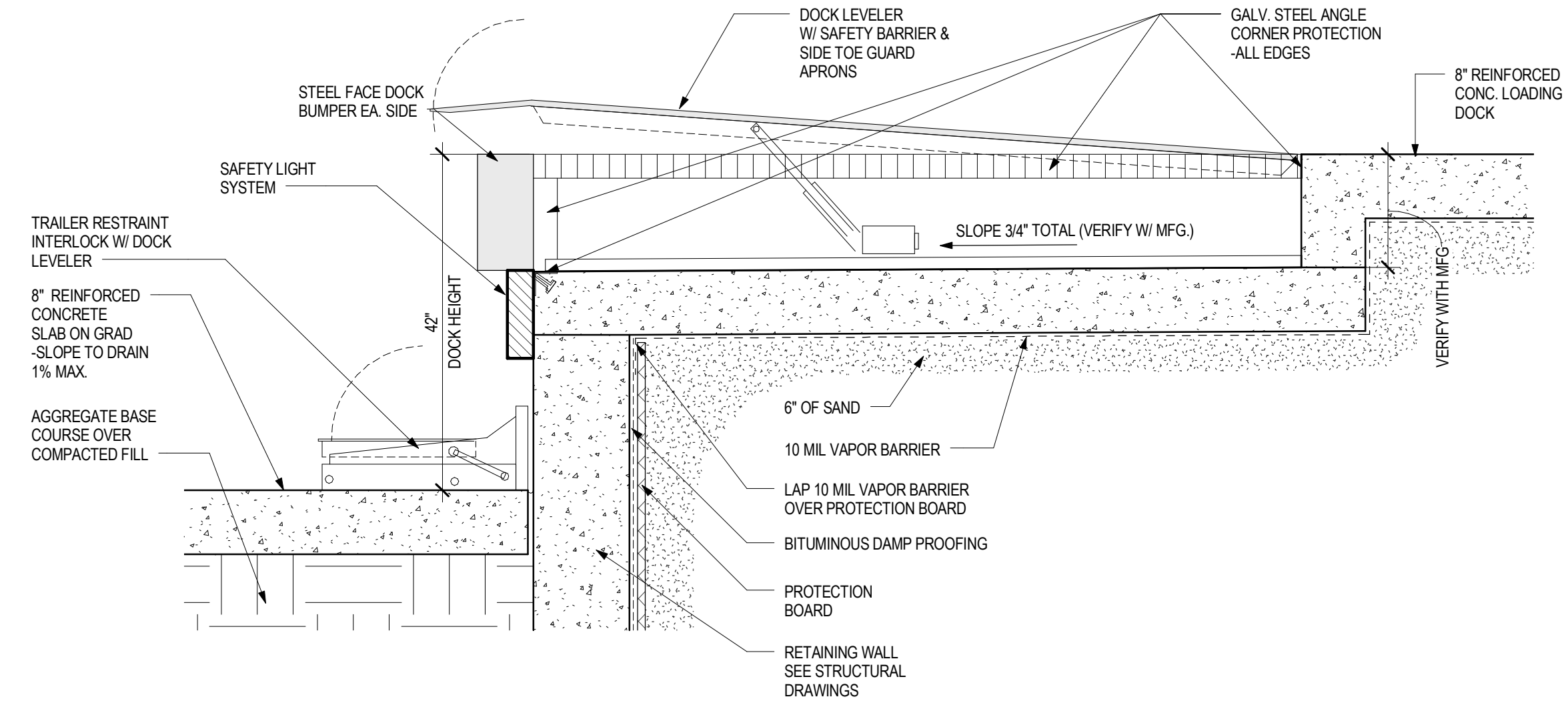

7 DOCK LEVELER PIT DETAIL
3/4" = 1'-0"

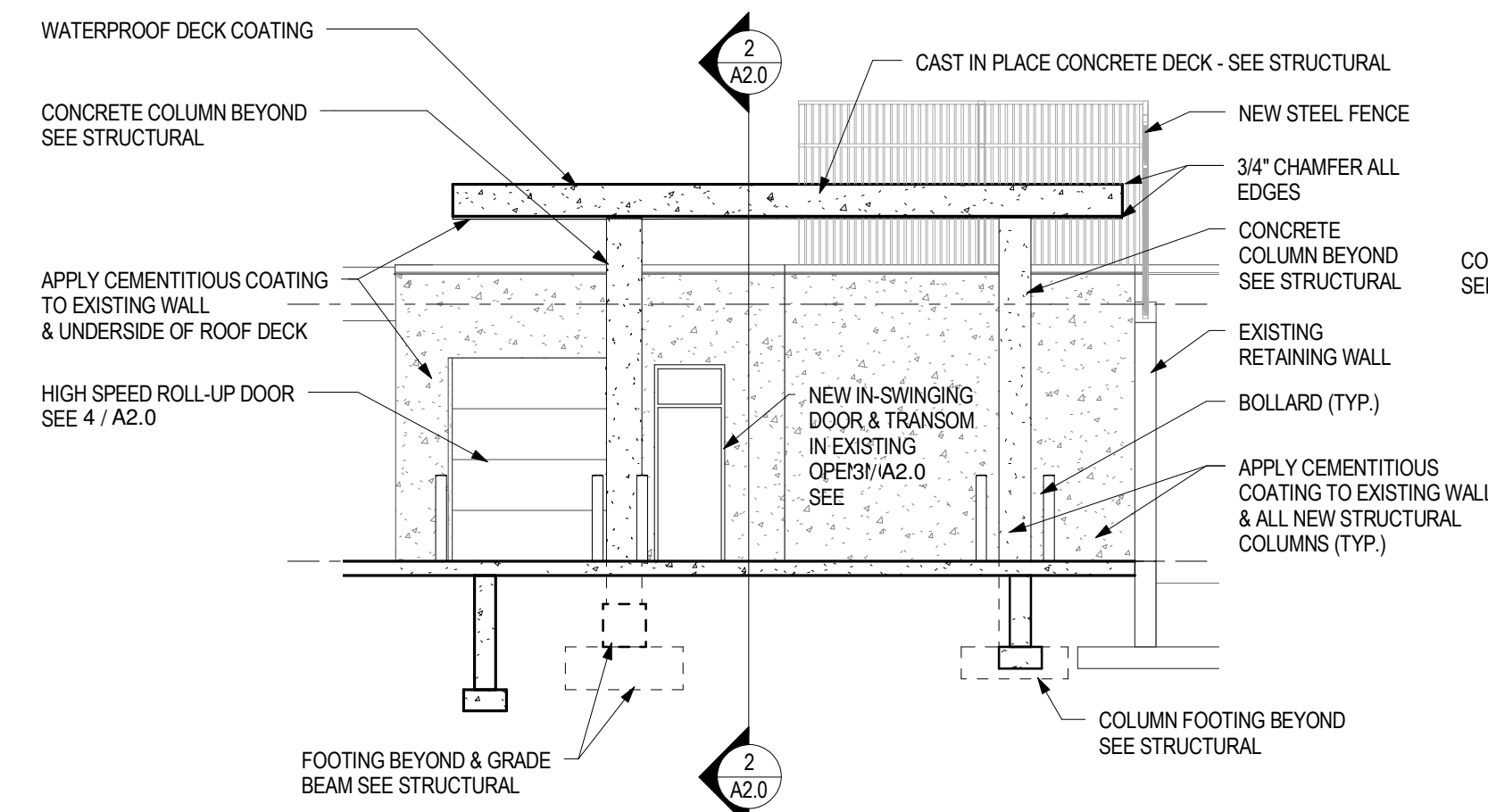

6 PLATFORM TRANSVERSE SECTION
1/8" = 1'-0"

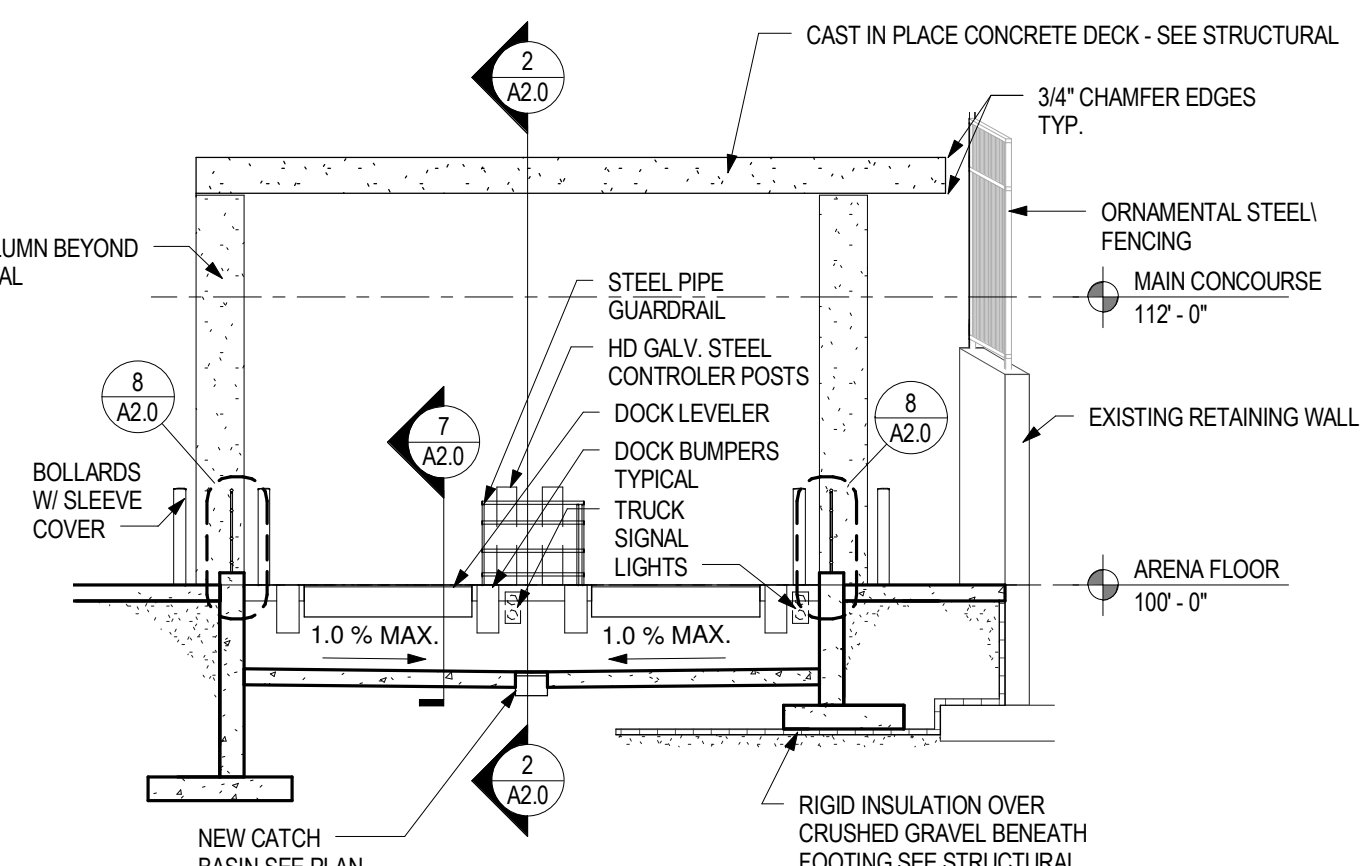

5 LOADING DOCK TRANSVERSE SECTION
1/8" = 1'-0"

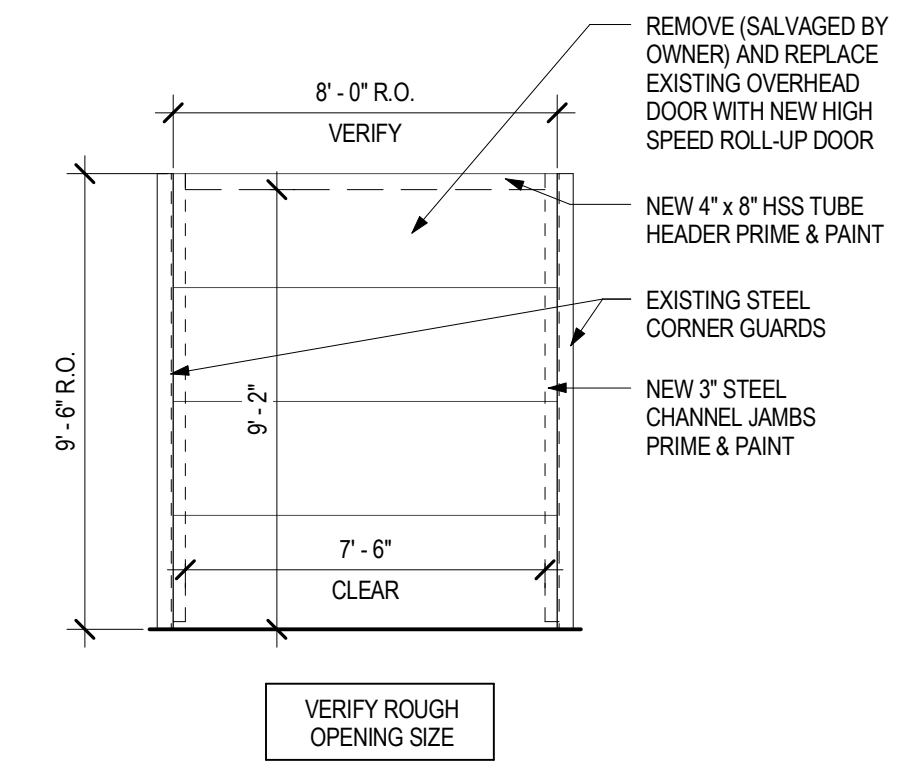

4 HIGH SPEED ROLL-UP DOOR
1/4" = 1'-0"

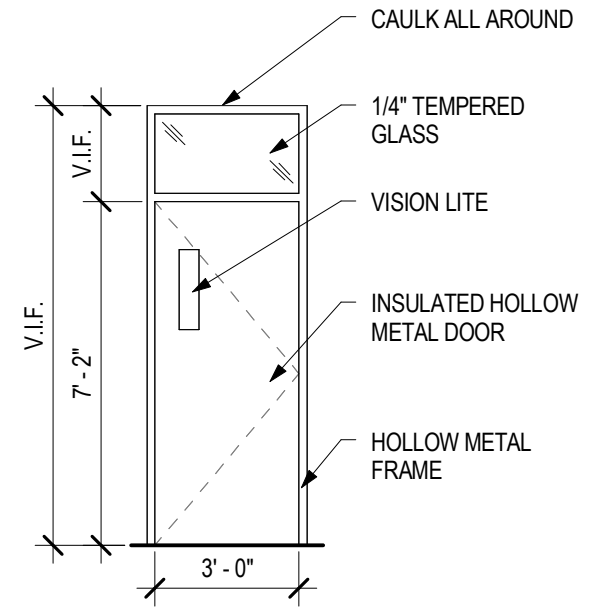

3 DOOR ELEVATION
1/4" = 1'-0"

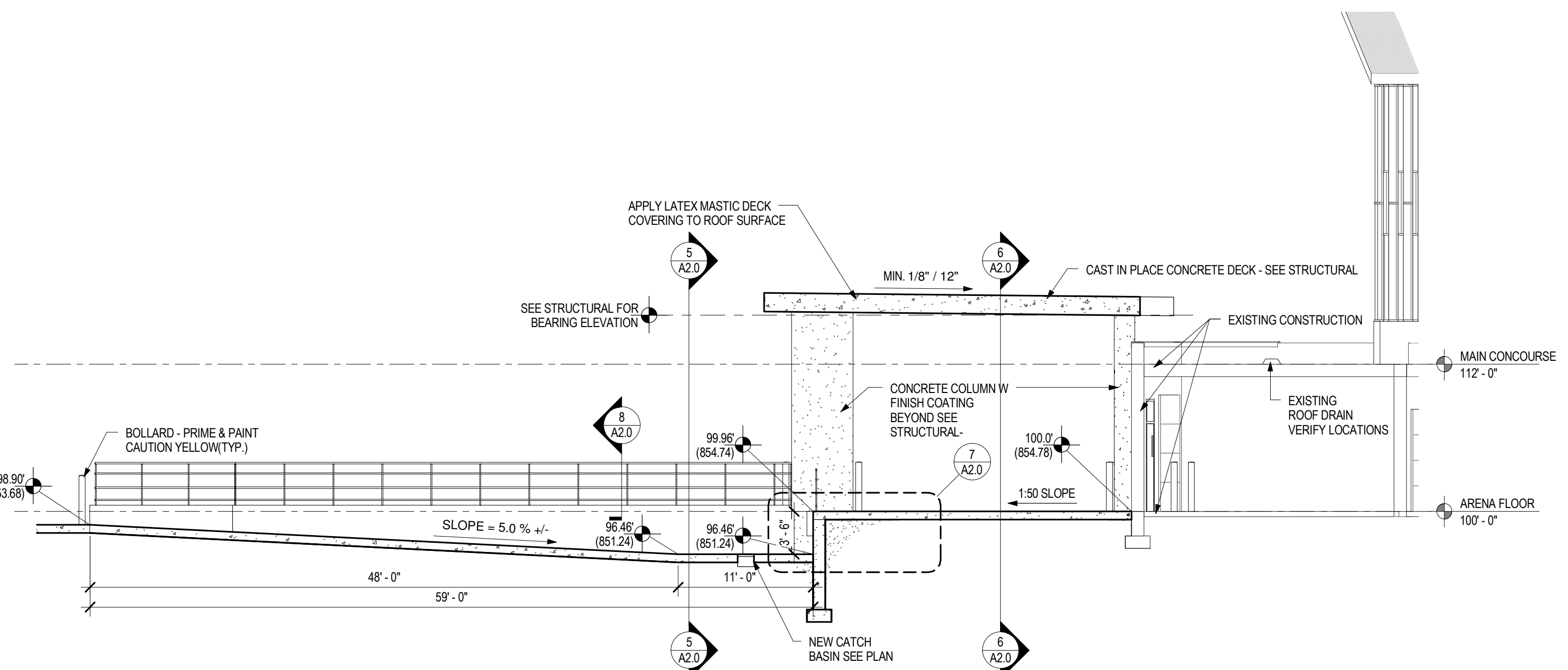

2 LOADING DOCK LONGITUDINAL SECTION
1/8" = 1'-0"

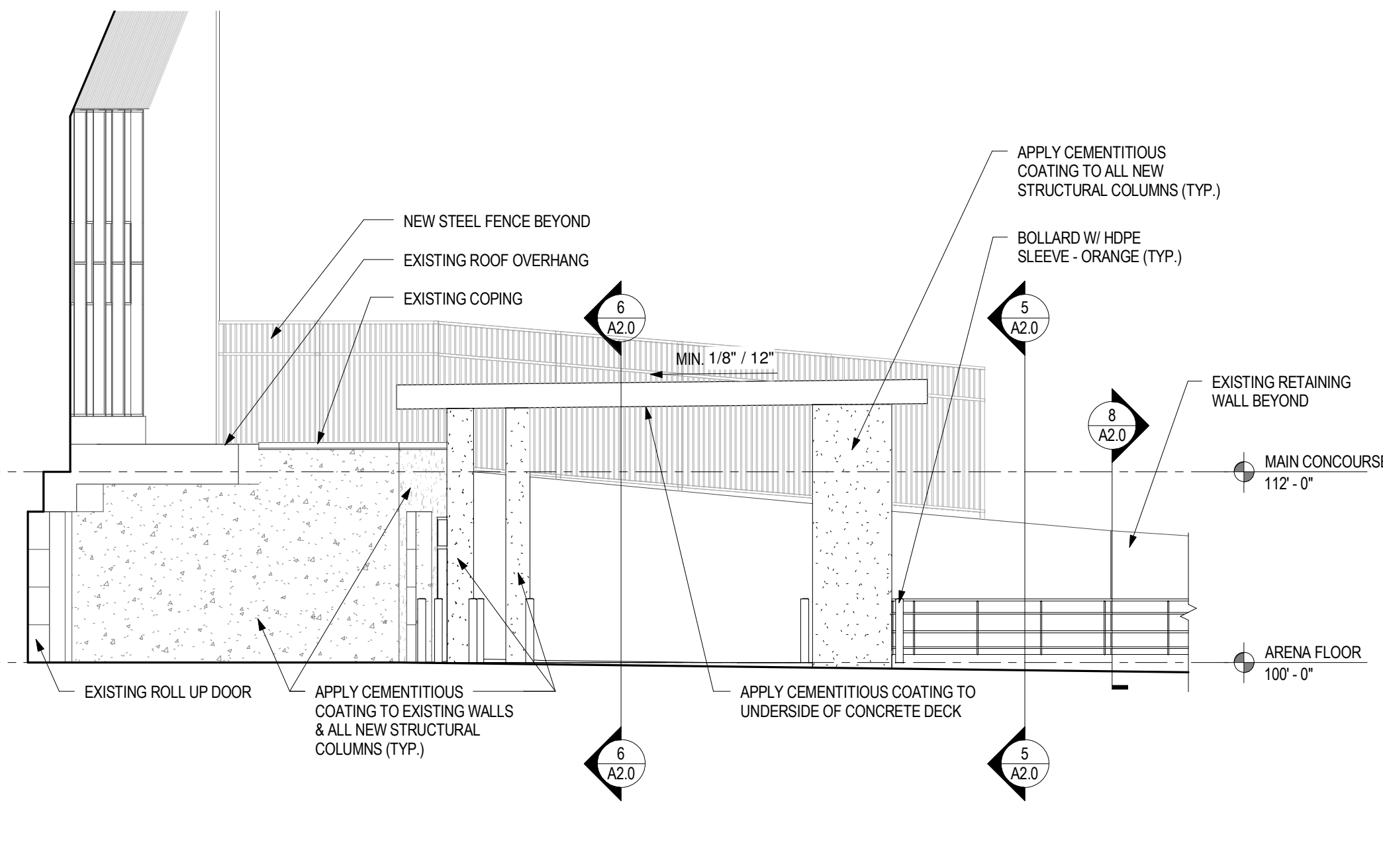

1 NORTHEAST ELEVATION
1/8" = 1'-0"

DATE OF ISSUE: 2/4/2016

REVISIONS:

PROJECT # 15019
REQUEST FOR BID # 316001

ELEVATIONS, SECTIONS & DETAILS

A2.0

**DANE COUNTY
COLISEUM LOADING
DOCKS**

1919 Alliant Energy Center Way,
Madison, WI 53713

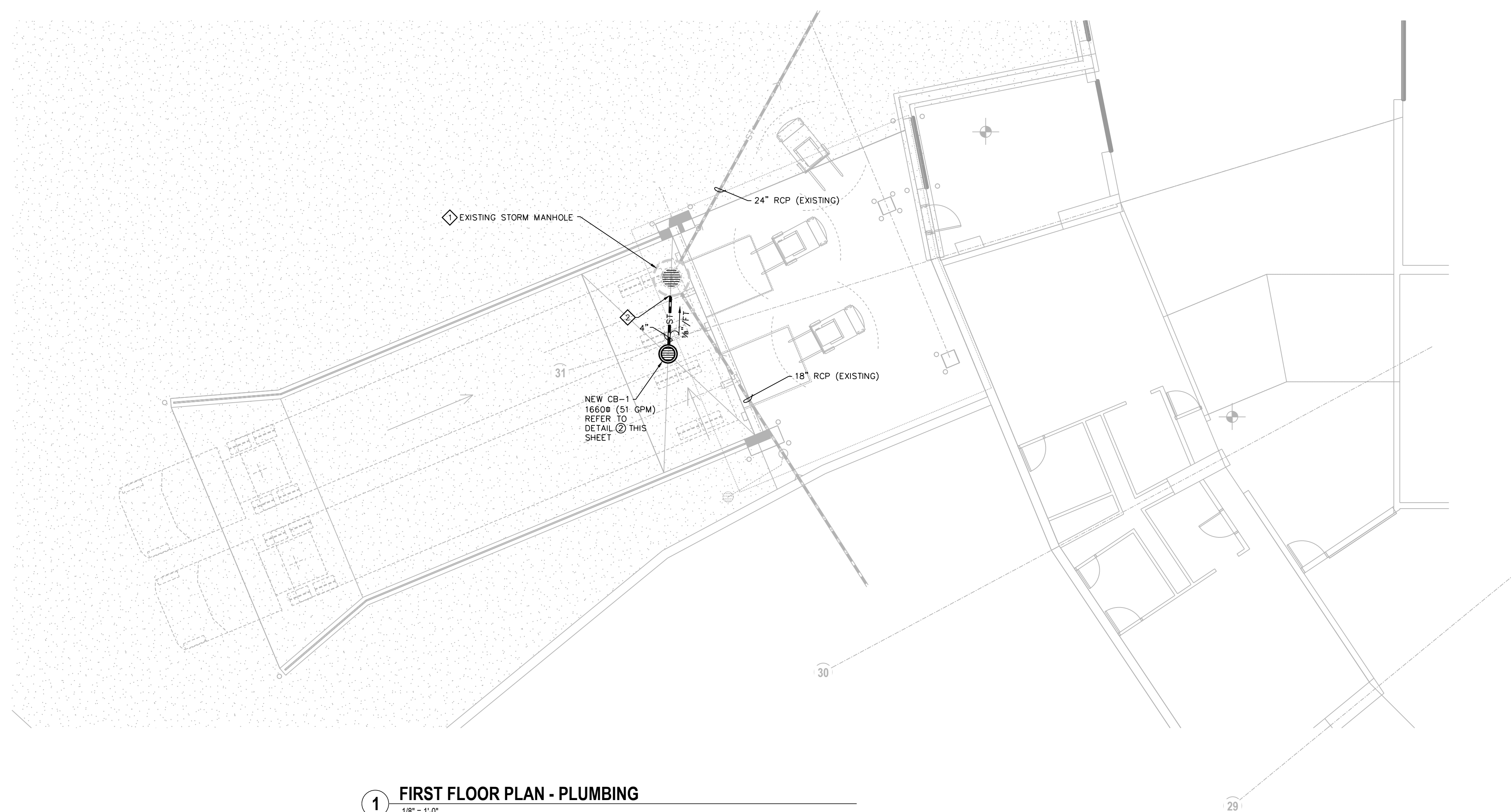

1 FIRST FLOOR PLAN - PLUMBING
1/8" = 1'-0"

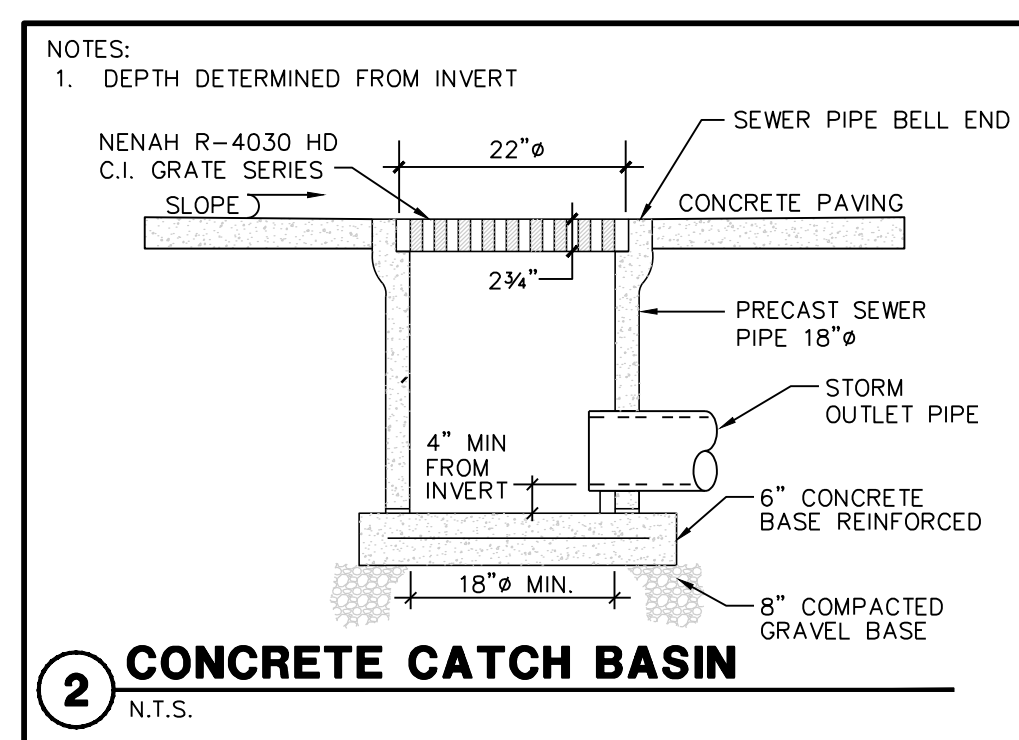

PLUMBING GENERAL NOTES:

1. PLUMBING CONTRACTOR IS RESPONSIBLE FOR FIELD VERIFYING ALL EXISTING CONDITIONS.
2. COORDINATE PIPING ROUTING WITH OTHER TRADES.
3. COORDINATE FINAL FINISH FLOOR FOR GRATE INLETS WITH THE GENERAL CONTRACTOR.

PLUMBING PLAN NOTES:

- ◇ LOWER INLET GRATE AND MANHOLE SECTIONS TO FLUSH WITH NEW ELEVATION OF RAMP PIT (APPROX. 4 FEET).
- ◇ CUT AND PATCH NEW 4"Ø OPENING IN EXISTING MANHOLE FOR NEW STORM LINE FROM CATCH BASIN CB-1.

PLUMBING SYMBOL SCHEDULE

SYMBOL	DESCRIPTION
---	EXISTING STORM BELOW GROUND
---ST---	STORM BELOW GROUND
⊙	GRATE
CB	CATCH BASIN
MH	MANHOLE

DATE OF ISSUE: 2/4/2016

REVISIONS:

PROJECT # 15019
REQUEST FOR BID # 316001

**FLOOR PLAN -
PLUMBING**

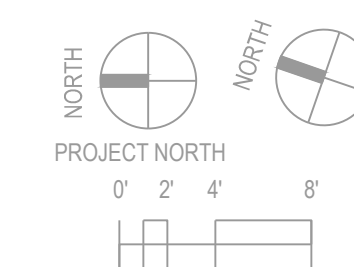

**DANE COUNTY
COLISEUM LOADING
DOCKS**

1919 Alliant Energy Center Way,
Madison, WI 53713

ELECTRICAL GENERAL NOTES:

- COORDINATE LIGHTING & DEVICE LAYOUT WITH GENERAL CONTRACTOR.
- COORDINATE ELECTRICAL RACEWAYS ROUTING WITH GENERAL CONTRACTOR AND OTHER TRADES FOR PROPER EQUIPMENT ACCESS.
- ALL RACEWAYS ARE TO BE CONCEALED IN FINISHED AREAS. MECHANICAL, UTILITY AND UNFINISHED EXISTING AREAS MAY USE SURFACE CONDUIT SYSTEMS.
- ELECTRICAL CONTRACTOR IS RESPONSIBLE FOR FIELD VERIFYING ALL EXISTING CONSTRUCTION CONDITIONS.

ELECTRICAL LIGHTING PLAN NOTES:

- ALL RACEWAYS IN ROOF CANOPY IMBEDDED IN CONCRETE. COORDINATE BACKBOX LOCATIONS AND RACEWAY INSTALLATION WITH GENERAL CONTRACTOR.
- LIQUID TIGHT FLEXIBLE CONDUIT CONNECTION TO ROOF CANOPY RACEWAY SYSTEM.
- CANOPY LIGHT CONTROLLED FROM PHOTOCELL ONLY.
- COORDINATE DOCK LEVELER CONTROL PANEL POWER & WIRING REQUIREMENTS WITH GENERAL CONTRACTOR AND EQUIPMENT CONTRACTOR.
- COORDINATE DOCK RESTRAINT CONTROL PANEL POWER & WIRING REQUIREMENTS WITH GENERAL CONTRACTOR AND EQUIPMENT CONTRACTOR.
- COORDINATE OVERHEAD DOOR (HIGH SPEED) POWER & WIRING REQUIREMENTS WITH GENERAL CONTRACTOR.
- GROUND STEEL STRUCTURE & METAL FENCE WITH #12 CU BOND CONDUCTOR PER NEC 250.104. COORDINATE WORK WITH GENERAL CONTRACTOR.
- COORDINATE FINAL ROUTING AND CONNECTION TO EXISTING ELECTRICAL DISTRIBUTION EQUIPMENT WITH OWNER'S SITE ELECTRICIAN.

ELECTRICAL SYMBOL SCHEDULE

MOUNTING HGT.	SYMBOL	DESCRIPTION
		LIGHTING FIXTURES
		LED: SURFACE MOUNTED
		LED: RECESSED
		LED: SURFACE WALL MOUNTED
		PHOTOCELL SENSOR
		SWITCHES
48"		SINGLE POLE WP: INDICATES WATERPROOF
48"		THREE WAY
48"		FOUR WAY
48"		SWITCH AND DUPLEX RECEPT. IN TWO GANG BOX
		RECEPTACLES
18"		DUPLEX: RECESSED- WP: INDICATES WATERPROOF
18"		DUPLEX: SURFACE
18"		TWO DUPLEX RECEPTACLES IN TWO GANG BOX
18"		TWO DUPLEX RECEPTACLES SURFACE MTD IN TWO GANG BOX
18"		DUPLEX: W/GROUND FAULT INTERRUPTION PROTECTION
		EQUIPMENT AND WIRING
		DIRECT EQUIPMENT CONNECTION
		MOTOR CONNECTION-SEE EQUIP. SCHEDULE FOR TYPE, WIRING, ETC.
		JUNCTION BOX-CONCEALED IN FINISHED AREAS, SURFACE IN UNFINISHED AREAS
		COMB. STARTER/ DISCONNECT
		SAFETY DISCONNECT SWITCH WITH COVER INTERLOCK-W.P. INDICATES WATERPROOF (NON-FUSED UNLESS INDICATED BY "F" -FUSED)
		MANUAL STARTER
		MOTOR STARTER-MAGNETIC UNLESS NOTED OTHERWISE
		ELECTRICAL POWER PANEL
		ABBREVIATIONS SUBSCRIPTS
		AFF = ABOVE FINISH FLOOR GFI = GROUND FAULT INTERRUPTER PC = PHOTOCELL CONTROLLED WP = WEATHERPROOF

DATE OF ISSUE: 2/4/2016

REVISIONS:

PROJECT # 15019
REQUEST FOR BID # 316001

**FLOOR PLAN -
ELECTRICAL**

E1.1

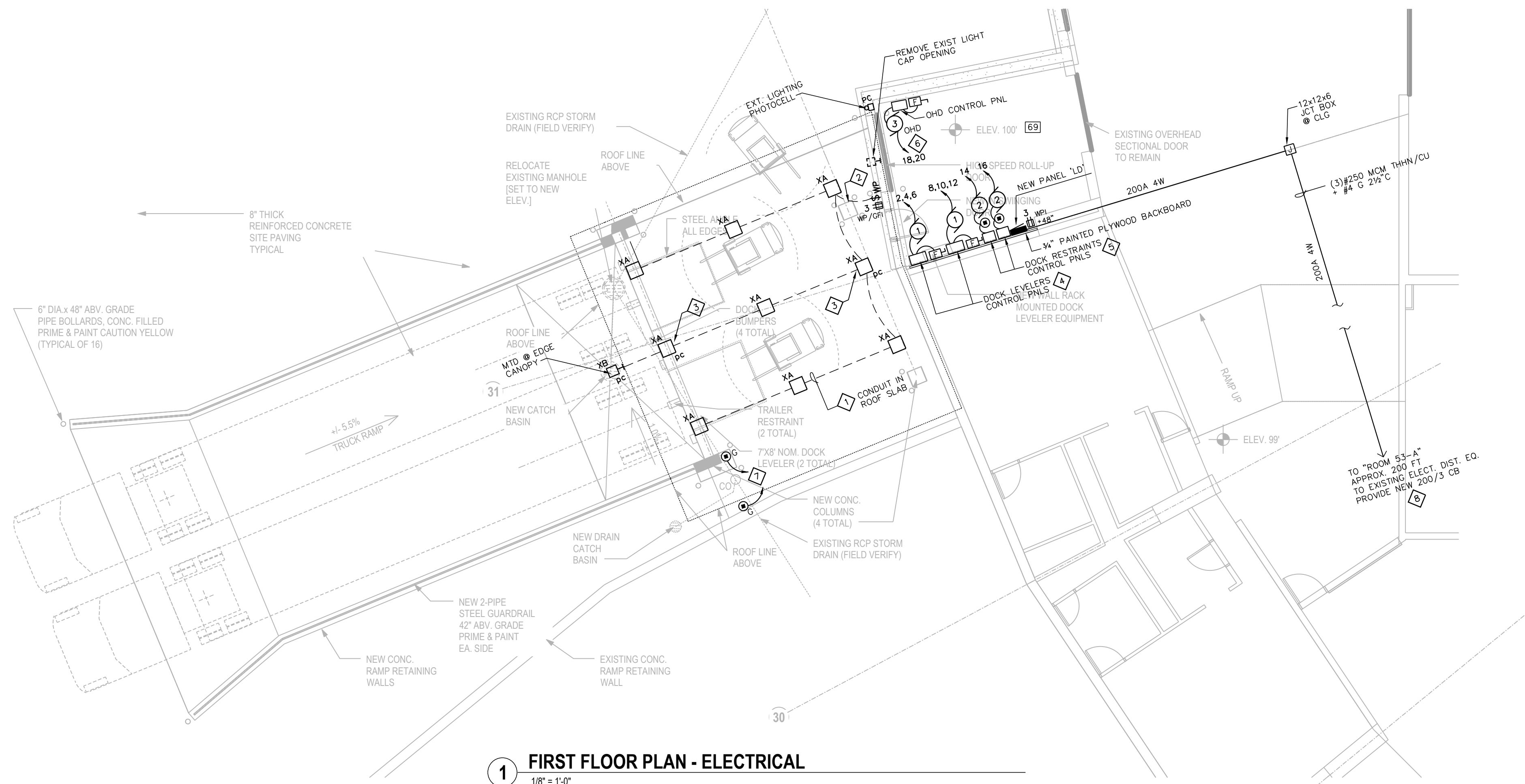

1 FIRST FLOOR PLAN - ELECTRICAL
1/8" = 1'-0"

ELECTRICAL MOTOR/EQUIPMENT SCHEDULE

TAG	①	②	③
PANEL NO.	LD	LD	LD
CIRCUIT	SEE PLAN	SEE PLAN	18,20
BREAKER	15	20	15
POLE	3	1	2
WIRING NO.	3+G (#12)	2+G (#12)	3+G (#12)
TYPE	THHN/CU	THHN/CU	THHN/CU
SIZE	#12	#12	#12
COND.	3/4"	1/2"	3/4"
ELECTRICAL HP (KW)	1	(1.2)	1
VOLT	208	115	208
PHASE	3	1	1
FLA (MCA)	5.4 (6.8)	10 (12.5)	9 (11.3)
STARTER TYPE	CONTROL PANEL	CONTROL PANEL	CONTROL PANEL
SIZE	-	-	-
BY	G.C.	G.C.	G.C.
CONTROL TYPE	MANUAL	MANUAL	RAISE/LOWER
BY	G.C.	G.C.	G.C.
DISCONNECT TYPE	HD	N.R.	HD
SIZE	30	-	30
FUSE	15	-	12
BY	E.C.	-	E.C.
REMARKS	DOCK LEVELER (2) REQ'D	DOCK RESTRAINT (2) REQ'D	OHD

E.C. = ELECTRICAL CONTRACTOR
H.C. = HVAC CONTRACTOR
P.C. = PLUMBING CONTRACTOR
G.C. = GENERAL CONTRACTOR
N.R. = NOT REQUIRED
G.D. = GENERAL DUTY
H.D. = HEAVY DUTY

P.L. = PILOT LIGHT
T.S. = TOGGLE SWITCH
F.T.S. = FUSED TOGGLE SWITCH
M.S. = MANUAL STARTER (FRAC HP)
T.U. = THERMAL UNIT
MAG = MAGNETIC STARTER
FVNR = FULL VOLTAGE NON-REVERSING
H.O.A. = HAND-OFF-AUTO SWITCH

① PROVIDE GREEN WIRE GROUND TO ALL MOTORS AND EQUIPMENT PER NEC 250-95.
② COORDINATE FINAL EQUIPMENT LOCATIONS & WIRING REQUIREMENTS WITH GENERAL CONTRACTOR.

LIGHTING FIXTURE SCHEDULE

TAG	NO.	TYPE	LAMPS WATTS	DESCRIPTION	MOUNTING	MFG. & MODEL	REMARKS
XA	-	LED	40	w/FIXTURE	SURFACE/SOFFIT	KENALL - MR17FFL-PP-DB-40L50K-SCC-DV	(1)(2) EXT. 17"Ø SURFACE LIGHT WET LOC.
XB	-	LED	47	w/FIXTURE	SURFACE/WALL	LITHONIA - DSXW1-LED-20C-700-50K-TFTM-MVOLT-PIR-DBBXD	(1)(2)(3) EXT. WALL LIGHT W/MOTION SENSOR BI-LEVEL DIMMER

LAMP ABBREVIATIONS:
LED=LIGHT EMITTING DIODE F=FLUORESCENT
CF=COMPACT FLUORESCENT

REMARKS:
(1) LED LAMPING AND DRIVER.
(2) DAMP OR WET LOCATION UL LISTED.
(3) INTEGRAL PHOTOCELL BI-LEVEL DIMMER - 34% OUTPUT @ NO MOTION DETECTION.

ALL FIXTURE VOLTAGES ARE 120 VOLT UNLESS INDICATED OTHERWISE.

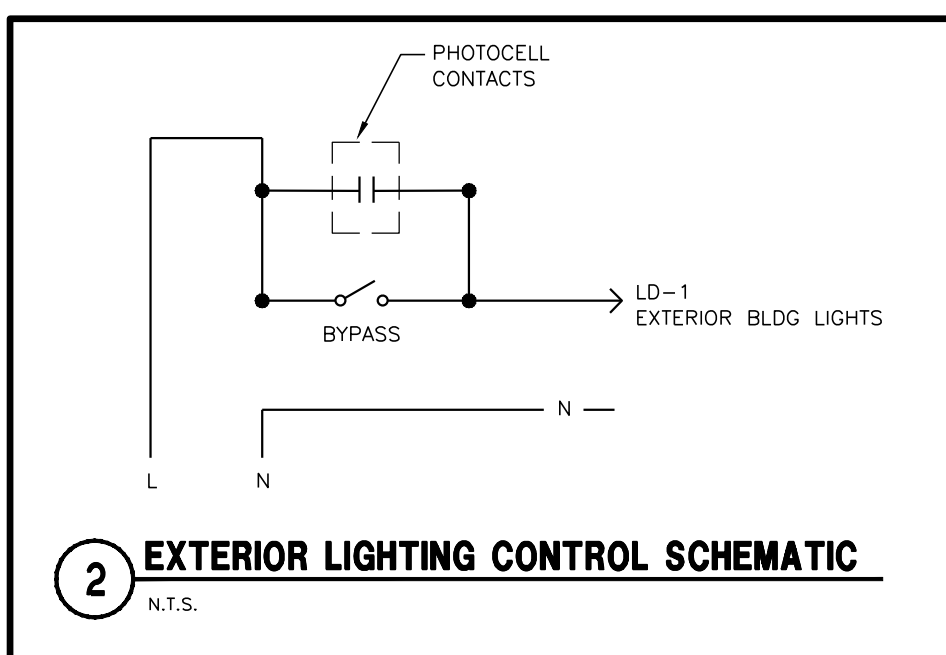

2 EXTERIOR LIGHTING CONTROL SCHEMATIC
N.T.S.

PANEL 'LD' AIC=10K

BRKR	DESCRIPTION	CIRCUIT	PHASELOADS	CIRCUIT	DESCRIPTION	BRKR
A	P	WATT	NO. A B C	NO. WATT		A P
20	1	410	1 1060	2	650 DOCK LEVELER - W	15 3
20	1	360	3 1010	4	650 DOCK LEVELER - W	- -
			5	650 DOCK LEVELER - W	- -	
			7	650 DOCK LEVELER - E	15 3	
			9	650 DOCK LEVELER - E	- -	
			11	650 DOCK LEVELER - E	- -	
			13	1200 DOCK RESTRAINT - W	20 1	
			15	1200 DOCK RESTRAINT - E	20 1	
			17	900 OHD	15 2	
			19	900 OHD	- -	
			21		- -	
			23		- -	
			25		- -	
			27		- -	
			29		- -	
		3810	2860	2200		

ESTIMATED DEMAND LOAD: 8870 WATTS / 24.6 AMPS
TOTAL CONNECTED LOADS: 8870 WATTS / 24.6 AMPS