

RFB NO. 318045



# **CONSTRUCTION DOCUMENTS PROJECT MANUAL**

DANE COUNTY DEPARTMENT OF PUBLIC WORKS,  
HIGHWAY AND TRANSPORTATION

**PUBLIC WORKS ENGINEERING DIVISION**  
1919 ALLIANT ENERGY CENTER WAY  
MADISON, WISCONSIN 53713

## **REQUEST FOR BIDS NO. 318045 JOB CENTER RESTROOM EXPANSION DANE COUNTY JOB CENTER 1819 ABERG AVE MADISON, WISCONSIN**

Due Date / Time: **TUESDAY, FEBRUARY 19, 2019 / 2:00 PM**

Location: **PUBLIC WORKS OFFICE**

Performance / Payment Bond: **100% OF CONTRACT AMOUNT**

Bid Deposit: **5% OF BID AMOUNT**

---

FOR INFORMATION ON THIS REQUEST FOR BIDS, PLEASE CONTACT:

ERIC URTESE, AIA, PROJECT MANAGER  
TELEPHONE NO.: 608/266-4798  
FAX NO.: 608/267-1533  
E-MAIL: [URTESE.ERIC@COUNTYOFDANE.COM](mailto:URTESE.ERIC@COUNTYOFDANE.COM)

## **TABLE OF CONTENTS FOR RFB NO. 318045**

### **DIVISION 00 - PROCUREMENT AND CONTRACTING REQUIREMENTS**

- Project Manual Cover Page
- Table of Contents
- Advertisement for Bids (Legal Notice)
- Best Value Contracting Application
- Instructions to Bidders
- Bid Form
- Fair Labor Practices Certification
- Sample Public Works Contract
- Sample Bid Bond
- Sample Performance Bond
- Sample Payment Bond
- General Conditions of Contract
- Supplementary Conditions

### **DIVISION 01 - GENERAL REQUIREMENTS**

- 01 00 00 - Basic Requirements
- 01 74 19 - Construction Waste Management, Disposal & Recycling

### **DIVISION 02 - EXISTING CONDITIONS**

- 02 41 19 Selective Structure Demolition

### **DIVISION 04 - MASONRY**

- 04 20 00 Unit Masonry
- 04 43 00 Stone Masonry

### **DIVISION 05 - METALS**

- 05 12 00 Structural Steel Framing
- 05 40 00 Cold-Formed Metal Framing
- 05 50 00 Metal Fabrications

### **DIVISION 06 - WOOD, PLASTICS AND COMPOSITES**

- 06 10 00 Rough Carpentry
- 06 41 16 Plastic Laminate Clad Casework
- 06 61 18 Solid Surface

### **DIVISION 07 - THERMAL AND MOISTURE PROTECTION**

- 07 14 00 Liquid-Applied Waterproofing
- 07 21 00 Building Insulation
- 07 92 00 Joint Sealants

### **DIVISION 08 - OPENINGS**

- 08 11 13 Hollow Metal Doors and Frames
- 08 14 16 Flush Wood Doors
- 08 31 13 Access Doors and Frames
- 08 41 13 Aluminum-Framed Entrances and Storefronts
- 08 71 00 Door Hardware
- 08 80 00 Glazing

### **DIVISION 09 - FINISHES**

- 09 29 00 Gypsum Board
- 09 30 00 Tiling

- 09 51 00 Acoustical Ceilings
- 09 65 00 Resilient Flooring
- 09 90 00 Painting

**DIVISION 10 - SPECIALTIES**

- 10 14 00 Information Specialties
- 10 21 13 Toilet Compartments
- 10 28 00 Toilet, Bath and Laundry Accessories
- 10 51 13 Lockers

**DIVISION 12 - FURNISHINGS**

- 12 24 13 Roller Window Shades

**DIVISION 21 - FIRE SUPPRESSION**

- 21 05 00 Common Work Results for Fire Suppression
- 21 05 29 Hangers and Supports for Fire Suppression Piping and Equipment
- 21 10 00 Water Based Fire Suppression Systems

**DIVISION 22 - PLUMBING**

- 22 05 00 Common Work Results for Plumbing
- 22 05 14 Plumbing Specialties
- 22 05 15 Piping Specialties
- 22 05 23 General Duty Valves for Plumbing Piping
- 22 05 29 Hangers and Supports for Plumbing Piping and Equipment
- 22 07 00 Plumbing Insulation
- 22 11 00 Facility Water Distribution
- 22 13 00 Sanitary Waste and Vent Piping
- 22 30 00 Plumbing Equipment
- 22 42 00 Commercial Plumbing Fixtures

**DIVISION 23 - HEATING, VENTILATING AND AIR CONDITIONING (HVAC)**

- 23 05 00 Common Work Results for HVAC
- 23 05 13 Common Motor Requirements for HVAC
  
- 23 05 15 Piping Specialties
- 23 05 23 General Duty Valves for HVAC
- 23 05 29 Hangers and Supports for HVAC Piping and Equipment
- 23 05 93 Testing, Adjusting and Balancing for HVAC
- 23 07 00 HVAC Insulation
- 23 09 14 HVAC Control
- 23 09 93 Sequence of Operation for HVAC Controls
  
- 23 21 13 Hydronic Piping
- 23 31 00 HVAC Ducts
- 23 33 00 Air Duct Accessories
- 23 34 00 HVAC Fans
- 23 37 13 Diffusers, Registers and Grilles
- 23 82 00 Heating Terminal Units

**DIVISION 26 - ELECTRICAL**

- 26 05 00 General Electrical Requirements
- 26 09 23 Occupancy Sensor Lighting Control System
- 26 20 00 Basic Materials and Methods
- 26 51 13 Lighting

**DIVISION 27 - COMMUNICATIONS**

- 27 10 00 Telecommunications Distribution System

**DIVISION 28 - ELECTRONIC SAFETY AND SECURITY**

- 28 31 00 Fire Alarm System

**DRAWINGS**

Plot drawings on 24" x 36" (ARCH D)

GENERAL

- G1.0 COVER SHEET AND INDEX OF DRAWINGS

ARCHITECTURAL

- A2.1 PARTIAL FIRST FLOOR PLANS, REFLECTED CEILING PLANS AND FINISH PLANS
- A7.0 DOOR SCHEDULE, INTERIOR ELEVATIONS AND DETAILS
- A7.1 INTERIOR ELEVATIONS

STRUCTURAL

- S001 STRUCTURAL GENERAL NOTES
- S501 STEEL FRAMING NOTES

FIRE PROTECTION

- FP1.0 PARTIAL FIRST FLOOR FIRE PROTECTION PLAN AND NOTES

PLUMBING

- P1.0 PARTIAL FIRST FLOOR PLANS, DEMOLITION/GENERAL PLUMBING NOTES, PLUMBING ABBREVIATIONS AND PLUMBING SYMBOLS
- P2.0 WASTE/VENT AND WATER PIPING DIAGRAM

HVAC

- M1.0 PARTIAL FIRST FLOOR HVAC DEMOLITION & NEW WORK PLANS
- M2.0 HVAC SCHEDULES AND DETAILS

ELECTRICAL

- E1.1 PARTIAL FIRST FLOOR ELECTRICAL DEMOLITION AND NEW PLANS
- E2.1 ELECTRICAL SCHEDULES AND DETAILS

**LEGAL NOTICE**

**INVITATION TO BID**

Dane County Dept. of Public Works, Hwy & Transp., 1919 Alliant Energy Center Way, Madison, WI 53713, will receive sealed Bids until:

**2:00 PM, TUESDAY, FEBRUARY 19, 2019**

**RFB NO. 318045**

**JOB CENTER RESTROOM EXPANSION**

**DANE COUNTY JOB CENTER**

**1819 ABERG AVE**

**MADISON, WI**

Dane County is inviting bids for construction services to renovate and expand the restrooms in the Dane County Job Center.

Request for Bids document may be obtained after **2:00 PM on Tuesday, January 22, 2019** by downloading it from [bids-pwht.countyofdane.com](http://bids-pwht.countyofdane.com). Please call Eric Urtes, AIA, Project Manager, at 608/266-4798, or our office at 608/266-4018, for any questions or additional information.

All Bidders must be pre-qualified as a Best Value Contractor before award of Contract. Complete Pre-qualification Application for Contractors at [countyofdane.com/pwht/BVC\\_Application.aspx](http://countyofdane.com/pwht/BVC_Application.aspx) or obtain one by calling 608/266-4029.

A pre-bid tour will be held Wednesday, February 6, 2019 at 1:30 PM at the Dane County Job Center, starting in the lobby. Bidders are strongly encouraged to attend this tour.

**PUBLISH:    JANUARY 22 & JANUARY 29, 2019 - WISCONSIN STATE JOURNAL  
                  JANUARY 22 & JANUARY 29, 2019 - THE DAILY REPORTER**



# DANE COUNTY DEPARTMENT of PUBLIC WORKS, HIGHWAY and TRANSPORTATION

County Executive  
Joseph T. Parisi

1919 Alliant Energy Center Way • Madison, Wisconsin 53713  
Phone: (608) 266-4018 • FAX: (608) 267-1533

Commissioner / Director  
Gerald J. Mandli

## BEST VALUE CONTRACTING APPLICATION

### CONTRACTORS / LICENSURE APPLICANTS

The Dane County Department of Public Works requires all contractors to be pre-qualified as a best value contractor with the County prior to being awarded a contract. In addition, the County pre-qualifies potential contractors and sub-contractors who wish to work on County contracts. Subcontractors must become pre-qualified ten (10) days prior to commencing work under any Dane County Public Works Contract. Potential subcontractors are urged to become pre-qualified as early as possible. This document shall be completed, properly executed, along with the necessary attachments and additional information that the County requires for the protection and welfare of the public in the performance of a County contract.

Contractors or subcontractors of any tier who attain pre-qualification status will retain that status for a period of two (2) years from the date of qualification. Contractors shall notify the Dane County Department of Public Works, Highway & Transportation within fifteen (15) days of any changes to its business or operations that are relevant to the pre-qualification application. Failure to do so could result in suspension, revocation of the contractor's pre-qualification, debarment from County contracts for up to three (3) years and / or other sanctions available under the law.

No contracts will be awarded for construction work performed on Dane County projects unless the contractor is currently approved as a Wisconsin Trade Trainer or has applied for approval as an Apprenticeship Trade Trainer to the Wisconsin Department of Workforce Development and agrees to an acceptable apprenticeship program. If you are not currently approved as a Wisconsin Trade Trainer, or have not applied for approval as an Apprenticeship Trade Trainer, please contact the Department of Workforce Development - Bureau of Apprenticeship Standards at 608/266-3133 or visit their web site at: [dwd.wisconsin.gov/apprenticeship/](http://dwd.wisconsin.gov/apprenticeship/).

### EXEMPTIONS

- Contractors who employ less than five (5) apprenticeable trade workers are not required to pre-qualify.
- Contractors performing work that does not apply to an apprenticeable trade, as outlined in Appendix A.
- The contractor / subcontractor provides sufficient documentation to demonstrate one or more of the following:
  - apprentices are not available in a specific geographic area;
  - the applicable apprenticeship program is unsuitable or unavailable; or
  - there is a documented depression of the local construction market which prevents compliance.

SEC.	PROOF OF RESPONSIBILITY	CHECK IF APPLICABLE
1	Does your firm possess all technical qualifications and resources, including equipment, personnel and financial resources, necessary to perform the work required for any project or obtain the same through the use of responsible, pre-qualified subcontractors?	Yes: <input type="checkbox"/> No: <input type="checkbox"/>
2	Will your firm possess all valid, effective licenses, registrations or certificates required by federal, state, county, or local law, which are necessary for the type of work to be performed including, but not limited to, those for any type of trade work or specialty work?	Yes: <input type="checkbox"/> No: <input type="checkbox"/>
3	Will your firm meet all bonding requirements as required by applicable law or contract specifications?	Yes: <input type="checkbox"/> No: <input type="checkbox"/>
4	Will your firm meet all insurance requirements as required by applicable law or specifications, including general liability insurance, workers compensation insurance and unemployment insurance requirements?	Yes: <input type="checkbox"/> No: <input type="checkbox"/>
5	Will your firm maintain a substance abuse policy for employees hired for public works contracts that comply with Wis. Stats. Sec. 103.503?	Yes: <input type="checkbox"/> No: <input type="checkbox"/>
6	Does your firm acknowledge that it must pay all craft employees on public works projects the wage rates and benefits required under Section 66.0903 of the Wisconsin Statutes?	Yes: <input type="checkbox"/> No: <input type="checkbox"/>
7	Will your firm fully abide by the equal opportunity and affirmative action requirements of all applicable laws, including County ordinances?	Yes: <input type="checkbox"/> No: <input type="checkbox"/>
8	In the past three (3) years, has your firm had control or has another corporation, partnership or other business entity operating in the construction industry controlled it? If so, please attach a statement explaining the nature of the firm relationship?	Yes: <input type="checkbox"/> No: <input type="checkbox"/> If Yes, attach details.
9	In the past three (3) years, has your firm had any type of business, contracting or trade license, certification or registration revoked or suspended?	Yes: <input type="checkbox"/> No: <input type="checkbox"/> If Yes, attach details.
10	In the past three (3) years, has your firm been debarred by any federal, state or local government agency?	Yes: <input type="checkbox"/> No: <input type="checkbox"/> If Yes, attach details.
11	In the past three (3) years, has your firm defaulted or failed to complete any contract?	Yes: <input type="checkbox"/> No: <input type="checkbox"/> If Yes, attach details.
12	In the past three (3) years, has your firm committed a willful violation of federal, state or local government safety laws as determined by a final decision of a court or government agency authority.	Yes: <input type="checkbox"/> No: <input type="checkbox"/> If Yes, attach details.
13	In the past three (3) years, has your firm been in violation of any law relating to your contracting business where the penalty for such violation resulted in the imposition of a penalty greater than \$10,000?	Yes: <input type="checkbox"/> No: <input type="checkbox"/> If Yes, attach details.
14	Is your firm Executive Order 108 precertified with the State of Wisconsin?	Yes: <input type="checkbox"/> No: <input type="checkbox"/>
15	Is your firm an active Wisconsin Trade Trainer as determined by the Wisconsin Bureau of Apprenticeship Standards?	Yes: <input type="checkbox"/> No: <input type="checkbox"/>
16	Is your firm exempt from being pre-qualified with Dane County?	Yes: <input type="checkbox"/> No: <input type="checkbox"/> If Yes, attach reason for exemption.
17	Does your firm acknowledge that in doing work under any County Public Works Contract, it will be required to use as subcontractors only those contractors that are also pre-qualified with the County or become so ten days prior to commencing work?	Yes: <input type="checkbox"/> No: <input type="checkbox"/>
18	Contractor has been in business less than one year?	Yes: <input type="checkbox"/> No: <input type="checkbox"/>
19	Is your firm a first time Contractor requesting a one time exemption, but, intend to comply on all future contracts and are taking steps typical of a "good faith" effort?	Yes: <input type="checkbox"/> No: <input type="checkbox"/>
20	Not applicable. My firm does not intend to work on Best Value Contracts. Note: Best Value Contracting is required to bid on most Public Works Contracts (if unclear, please call Jan Neitzel Knox 608-266-4029).	Yes: <input type="checkbox"/> No: <input type="checkbox"/>

## SIGNATURE SECTION

Your firm's Officer, or the individual who would sign a bid and / or contract documents must sign this document.

I do hereby certify that all statements herein contained are true and correct to the best of my knowledge:

Signature \_\_\_\_\_

Date \_\_\_\_\_

Printed or Typed Name and Title \_\_\_\_\_

NAME AND ADDRESS OF CONTRACTOR	
Name of Firm:	
Address:	
City, State, Zip:	
Telephone Number:	
Fax Number:	
E-mail Address:	

## REMEMBER!

Return all to forms and attachments, or questions to:

**DANE COUNTY DEPARTMENT OF PUBLIC WORKS,  
HIGHWAY & TRANSPORTATION  
1919 ALLIANT ENERGY CENTER WAY  
MADISON, WI 53713**

**OFFICE: (608) 266-4018**



## APPENDIX A

### APPRENTICEABLE TRADES

Bricklayer  
Carpenter  
Cement Mason (Concrete Finisher)  
Cement Mason (Heavy Highway)  
Construction Craft Laborer  
Data Communications Installer  
Electrician  
Elevator Mechanic / Technician  
Environmental Systems Technician / HVAC Service Technician / HVAC Install & Service  
Glazier  
Heavy Equipment Operator / Operating Engineer  
Insulation Worker (Heat & Frost)  
Iron Worker (Assembler, Metal Buildings)  
Painter / Decorator  
Plasterer  
Plumber  
Roofer / Waterproofer  
Sheet Metal Worker  
Sprinkler Fitter  
Steamfitter (Service & Refrigeration)  
Taper & Finisher  
Telecommunications (Voice, Data & Video) Installer / Technician  
Tile Setter

# INSTRUCTIONS TO BIDDERS

## TABLE OF CONTENTS

1. GENERAL.....	1
2. DRAWINGS AND SPECIFICATIONS .....	1
3. INTERPRETATION .....	2
4. QUALIFICATIONS OF BIDDER (CONTRACTOR AND SUBCONTRACTOR)....	2
5. BID GUARANTEE .....	2
6. WITHDRAWAL OF BIDS.....	3
7. CONTRACT FORM.....	3
8. CONTRACT INTERESTS BY COUNTY PUBLIC OFFICIALS .....	3
9. EMERGING SMALL BUSINESS PROVISIONS .....	3
10. METHOD OF AWARD - RESERVATIONS .....	5
11. SECURITY FOR PERFORMANCE AND PAYMENTS .....	5
12. TAXES.....	6
13. SUBMISSION OF BIDS .....	6
14. SUBCONTRACTOR LISTING.....	7
15. ALTERNATE BIDS .....	7
16. INFORMATIONAL BIDS .....	7
17. UNIT PRICES.....	7
18. COMMENCEMENT AND COMPLETION .....	8
19. WORK BY OWNER .....	8
20. SPECIAL HAZARDS COVERAGE.....	8
FORM A .....	9
FORM B.....	10
FORM C.....	11
FORM D .....	12

### **1. GENERAL**

- A. Before submitting Bid, bidder shall thoroughly examine all Construction Documents. Successful Bidder shall be required to provide all the Work that is shown on Drawings, set forth in Specifications, or reasonably implied as necessary to complete Contract for this project.
- B. Bidder shall visit site to become acquainted with adjacent areas, means of approach to site, conditions of actual site and facilities for delivering, storing, placing, and handling of materials and equipment.
- C. Pre-bid meeting is scheduled on February 6, 2018 at 1:30 p.m. at the Dane County Job Center, 1819 Aberg Ave, in the lobby. Attendance by all bidders is optional, however bidders and subcontractors are strongly encouraged to attend.
- D. Visits at other times can also be arranged. Coordinate site access activities with, Liza Ingrilli, 608/283-1338.
- E. Failure to visit site or failure to examine any and all Construction Documents will in no way relieve successful Bidder from necessity of furnishing any necessary materials or equipment, or performing any work, that may be required to complete the Work in accordance with Drawings and Specifications. Neglect of above requirements will not be accepted as reason for delay in the Work or additional compensation.

### **2. DRAWINGS AND SPECIFICATIONS**

- A. Drawings and Specifications that form part of this Contract, as stated in Article 1 of General Conditions of Contract, are enumerated in Document Index of these Construction Documents.
- B. Complete sets of Drawings and Specifications for all trades will be available to all Bidders, irrespective of category of work to be bid on, in order that all Bidders may be familiar with work of other trades as they affect their bid.

### **3. INTERPRETATION**

- A. No verbal explanation or instructions will be given in regard to meaning of Drawings or Specifications before Bid Due Date. Bidders shall bring inadequacies, omissions or conflicts to Owner or Architect / Engineer's attention at least ten (10) calendar days before Bid Due Date. Prompt clarification will be available to all bidders by Addendum.
- B. Failure to so request clarification or interpretation of Drawings and Specifications will not relieve successful Bidder of responsibility. Signing of Contract will be considered as implicitly denoting that Contractor has thorough understanding of scope of the Work and comprehension of Construction Documents.
- C. Owner will not be responsible for verbal instructions.

### **4. QUALIFICATIONS OF BIDDER (CONTRACTOR AND SUBCONTRACTOR)**

- A. Before award of Contract can be approved, Owner shall be satisfied that Bidder involved meets following requirements:
  - 1. Has completed at least one (1) project of at least fifty percent (50%) of size or value of Division of work being bid and type of work completed is similar to that being bid. If greater magnitude of experience is deemed necessary, other than size or value of work, such requirements will be described in appropriate section of Specifications.
  - 2. Maintains permanent place of business.
  - 3. Can be bonded for terms of proposed Contract.
- B. County's Public Works Project Engineer will make such investigations as are deemed necessary to determine ability of bidder to perform the Work, and bidder shall furnish to County's Public Works Project Engineer or designee all such information and data for this purpose as County's Public Works Project Engineer may request. Owner reserves right to reject Bid if evidence submitted by, or investigation of, bidder fails to satisfy Owner that bidder is responsible and qualified to carry out obligations of Contract and to complete the Work contemplated therein.

### **5. BID GUARANTEE**

- A. Bank certified check, cashier's check or Bid Bond, payable to County in amount not less than five percent (5%) of maximum bid, shall accompany each Bid as guarantee that if Bid is accepted, Bidder will execute and return proposed Contract and Performance and Payment Bonds within ten (10) business days after being notified of acceptance of Bid. Company issuing bonds must be licensed to do business in Wisconsin.
- B. Any bid, which is not accompanied by bid guarantee, will be considered "No Bid" and will not be read at Bid Due Date.

- C. If successful Bidder so delivers Contract, Certificate of Insurance, and Performance and Payment Bonds, check will be returned to Bidder. In case Bidder fails to deliver such Contract, insurance, and bond, amount of bid guarantee will be forfeited to County as liquidated damages.
- D. All checks tendered as bid guarantee, except those of three (3) lowest qualified, responsible bidders, will be returned to their makers within three (3) business days after Bid Due Date. All such retained checks will be returned immediately upon signing of Contract and Performance and Payment Bonds by successful Bidder.

## **6. WITHDRAWAL OF BIDS**

- A. Bids may be withdrawn by written request received from bidder or authorized representative thereof prior to time fixed for Bid Due Date, without prejudice to right of bidder to file new Bid. Withdrawn Bids will be returned unopened. Negligence on part of bidder in preparing their Bid confers no right for withdrawal of Bid after it has been opened.
- B. No Bid may be withdrawn for period of sixty (60) calendar days after Bid Due Date.
- C. If Bid contains error, omission or mistake, bidder may limit liability to amount of bidder's guarantee by giving written Notice of Intent not to execute Contract to Owner within seventy-two (72) hours of Bid Due Date.

## **7. CONTRACT FORM**

- A. Sample copy of contract that successful Bidder will be required to enter into is included in these Construction Documents and bidders are required to familiarize themselves with all conditions contained therein.

## **8. CONTRACT INTERESTS BY COUNTY PUBLIC OFFICIALS**

- A. In accordance with Wisconsin Statute 946.13, county official may not bid for or enter into any contract involving receipts or disbursements of more than \$15,000.00 in a year, in which they have private pecuniary interest, direct or indirect if at same time they are authorized to take official action with respect to making of this Contract. Any contract entered into in violation of this Statute is void and County incurs no liability thereon. This subsection does not affect application and enforcement of Wisconsin Statute 946.13 by state prosecutors in criminal courts of this state.

## **9. EMERGING SMALL BUSINESS PROVISIONS**

- A. **Emerging Small Business Definition.** For purposes of this provision, ESB is defined as:
  - 1. Independent business concern that has been in business minimum of one year;
  - 2. Business located in State of Wisconsin;
  - 3. Business comprised of less than twenty-five (25) employees;
  - 4. Business must not have gross sales in excess of three million dollars (\$3,000,000.00) over past three years; and
  - 5. Business does not have history of failing to complete projects.

- B. **Emerging Small Business (ESB) Involvement.** Bidder shall make good faith effort to award minimum of ten percent (10%) of the Work to ESBs. Bidder shall submit report to Dane County Contract Compliance Officer within ten (10) business days of Bid Due Date demonstrating such efforts. Good faith efforts means significant contact with ESBs for purposes of soliciting bids from them. Failure to make or demonstrate good faith efforts will be grounds for disqualification.
- C. **Emerging Small Business Report.** Emerging Small Business Enterprise Report is to be submitted by Bidder in separate envelope marked "Emerging Small Business Report". This report is due by 2:00 p.m. following specified ten (10) business days after Bid Due Date. Bidder who fails to submit Emerging Small Business Report shall be deemed not responsive.
- D. **ESB Goal.** Goal of this project is ten percent (10%) ESB participation. ESB utilizations are shown as percentage of total Bid. If Bidder meets or exceeds specified goal, Bidder is only required to submit Form A - Certification, and Form B - Involvement. Goal shall be met if Bidder qualifies as ESB.
- E. **Report Contents.** Following award of Contract, Bidder shall submit copies of executed contracts for all Emerging Small Businesses. Emerging Small Business Report shall consist of these:
1. Form A - Certification;
  2. Form B - Involvement;
  3. Form C - Contacts;
  4. Form D - Certification Statement (if appropriate); and
  5. Supportive documentation (i.e., copies of correspondence, telephone logs, copies of advertisements).
- F. **ESB Listing.** Bidders may solicit bids from this ESB listing: [pdf.countyofdane.com/commissions/2013-2015\\_Targeted\\_Business\\_Directory.pdf](http://pdf.countyofdane.com/commissions/2013-2015_Targeted_Business_Directory.pdf).
- G. **ESB Certification.** All contractors, subcontractors and suppliers seeking ESB certification must complete and submit Emerging Small Business Report to Dane County Contract Compliance Program.
- H. **Certification Statement.** If ESB firm has not been certified by County as ESB prior to submittal of this Bid, ESB Report cannot be used to fulfill ESB goal for this project unless firm provides "Form D - Certification Statement". Certification statement must be completed and signed by ESB firm.
- I. **Questions.** Questions concerning Emerging Small Business provisions shall be directed to:
- Dane County Contract Compliance Officer  
City-County Building, Room 421  
210 Martin Luther King, Jr. Blvd.  
Madison, WI 53703  
608/266-5623
- J. **Substituting ESBs.** In event of any significant changes in subcontract arrangements or if need arises to substitute ESBs, Bidder shall report such proposed changes to Contract Compliance Officer to making any official changes and request authorization to substitute

ESB firm. Bidder further agrees to make every possible effort to replace ESB firm with another qualified ESB firm.

K. **Good Faith Efforts.** Good faith efforts can be demonstrated by meeting all of these obligations:

1. Selecting portions of the Work to be performed by ESBs in order to increase likelihood of meeting ESB goal including, where appropriate, breaking down Contract into smaller units to facilitate ESB participation.
2. Advertising in general circulation, trade associations and women / minority focus media concerning subcontracting opportunities.
3. Providing written notices to reasonable number of specific ESBs that their interest in Contract was being solicited in sufficient time to allow ESBs to participate effectively.
4. Following up on initial solicitations of interest by contacting ESBs within five (5) business days prior to Bid Due Date to determine with certainty whether ESB were interested, to allow ESBs to prepare bids.
5. Providing interested ESB with adequate information about Drawings, Specifications and requirements of Contract.
6. Using services of available minority, women and small business organizations and other organizations that provide assistance in recruitment of MBEs / WBEs / ESBs.
7. Negotiating in good faith with interested ESBs, not rejecting ESBs as unqualified without sound reason based on thorough investigation of their capabilities.
8. Submitting required project reports and accompanying documents to County's Contract Compliance Officer within twenty-four (24) hours after Bid Due Date.

L. **Appeals Disqualification of Bid.** Bidder who is disqualified may appeal to Public Works & Transportation Committee and Equal Opportunity Commission.

## 10. METHOD OF AWARD - RESERVATIONS

- A. Following will be basis of award of Contract, providing cost does not exceed amount of funds then estimated by County as available to finance Contract(s):
1. Lowest dollar amount submitted by qualified responsible bidder on Base Bid for all work comprising project, combined with such additive Owner accepted alternates.
  2. Owner reserves right to reject all bids or any bid, to waive any informality in any bid, and to accept any bid that will best serve interests of County.
  3. Unit Prices and Informational Bids will not be considered in establishing low bidder.

## 11. SECURITY FOR PERFORMANCE AND PAYMENTS

- A. Simultaneous with delivery of signed Contract, Bidder shall be required to furnish Performance and Payment Bonds as specified in Article 29 of General Conditions of Contract, "Contract Security". Surety Company shall be licensed to do business in Wisconsin. Performance and Payment Bonds must be dated same date or subsequent to date of Contract. Performance and Payment Bonds must emulate information in Sample Performance and Payment Bonds in Construction Documents.

- B. Provide certified copy of power of attorney from Surety Company showing that agent who signs Bond has power of attorney to sign for Surety Company. Secretary or Assistant Secretary of company must sign this certification, not attorney-in-fact. Certification must bear same or later date as Bond. Power of Attorney must emulate model power of attorney information detailed in Sample Performance and Payment Bonds.
- C. If Bidder is partnership or joint venture, State certified list, providing names of individuals constituting partnership or joint venture must be furnished. Contract itself may be signed by one partner of partnership, or one partner of each firm comprising joint venture, but Performance and Payment Bonds must be signed by all partners.
- D. If Bidder is corporation, it is necessary that current certified copy of resolution or other official act of directors of corporation be submitted showing that person who signs Contract is authorized to sign contracts for corporation. It is also necessary that corporate seal be affixed to resolution, contract, and performance and payment bonds. If your corporation has no seal, it is required that above documents include statement or notation to effect that corporation has no seal.

## **12. TAXES**

- A. Wisconsin Statute 77.54 (9m) allows building materials that become part of local unit government facilities to be exempt from sales & use tax. Vendors & materials suppliers may not charge Bidders sales & use tax on these purchases. This does not include highways, streets or roads. Any other Sales, Consumer, Use & other similar taxes or fees required by law shall be included in Bid.
- B. In accordance with Wisconsin Statute 71.80(16)(a), successful nonresident bidder, whether incorporated or not, and not otherwise regularly engaged in business in this state, shall file surety bond with State of Wisconsin Department of Revenue payable to Department of Revenue, to guarantee payment of income taxes, required unemployment compensation contributions, sales and use taxes and income taxes withheld from wages of employees, together with any penalties and interest thereon. Amount of bond shall be three percent (3%) of Contract or subcontract price on all contracts of \$50,000 or more.

## **13. SUBMISSION OF BIDS**

- A. All Bids shall be submitted on standard Bid Form bound herein and only Bids that are made on this Bid Form will be considered. Entire Bid Form and other supporting documents, if any, shall be removed or copied from Construction Documents, filled out, and submitted in manner specified hereinafter. Submit completed Bid Bond with Bid as well.
- B. No bids for any subdivision or any sub-classification of this Work, except as indicated, will be accepted. Any conditional Bid, amendment to Bid Form or appended item thereto, or inclusion of any correspondence, written or printed matter, or details of any nature other than that specifically called for, which would alter any essential provision of Construction Documents, or require consideration of unsolicited material or data in determining award of Contract, will disqualify Bid. Telecommunication alterations to Bid will not be accepted.
- C. Bidders must submit single Bid for all the Work.
- D. Bid amounts shall be inserted in words and in figures in spaces provided on Bid Form; in case of conflict, written word amounts will govern.
- E. Addenda issued after Bid Letting shall become part of Construction Documents. Bidders shall acknowledge receipt of such addenda in appropriate space provided on Bid Form. Bid

may be rejected if receipt of any particular addendum applicable to award of Contract has not been acknowledged on Bid Form.

- F. Bids shall be signed, placed in envelope, sealed and delivered before due time to place designated in Invitation to Bid, and identified with project name, bid number, location, category of work being bid upon, Bid Due Date, name and address of bidder.
- G. Bidder shall be responsible for sealed Bid being delivered to place designated for Bid Due Date on or before date and time specified. Bids received after time of closing will be rejected and returned to bidder unopened.
- H. Bid will be considered invalid and will be rejected if bidder has not signed it.
- I. Faxed or emailed Bids will not be accepted.
- J. Bidder's organization shall submit completed with Bid, Fair Labor Practices Certification form, included in these Construction Documents.

#### **14. SUBCONTRACTOR LISTING**

- A. Bidders shall be required to submit list of major subcontractors for General Construction, Plumbing, HVAC, and Electrical work proposed for this project to include committed prices for each subcontractor. List shall be placed in separate sealed envelope that must be clearly identified as "Major Subcontractor List", for named project and name of Bidder submitting it. County must receive envelope no later than date by which successful Bidder is required to submit his or her signed Contract, as established in Construction Documents.

#### **15. ALTERNATE BIDS**

- A. Bidder shall carefully read requests for Alternate Bids, and thoroughly examine Drawings and Specifications to determine extent various changes and conditions will affect Bid.
- B. Space is provided in Bid Form for requested Alternate Bids. Failure to submit bid for any requested Alternate Bids may result in rejection of entire Bid.
- C. Bidder shall state amount to be added / subtracted to Base Bid for providing alternates, including all incidentals, omissions, additions, and adjustments as may be necessary or required by such changes. If there is no difference in price, Bidder shall state, "No Change".
- D. Descriptions of requested Alternate Bids are as set forth in Construction Documents.

#### **16. INFORMATIONAL BIDS**

- A. Bidder shall state amount that is included in Base Bid for all equipment, materials and labor required to complete the Work described. Informational bids are amounts requested for accounting purposes and for allocation of funds only. It is not intended to omit any of the Work described or related items from this project.
- B. Description of requested Informational Bids, if any, is as set forth in Construction Documents.

#### **17. UNIT PRICES**

- A. Provide unit prices where requested on Bid Form. Unit prices will include all costs for materials, labor, insurance, taxes, overhead and profit necessary to perform specified work.



Estimated quantities are approximate only. Payment will be based upon actual quantities placed, provided or installed. Failure to provide requested unit prices may result in rejection of entire Bid.

- B. Owner reserves right to accept or reject any unit prices as given in Bid.
- C. Bidder shall refer to Bid Form and applicable specification section to determine basis of unit measure and detailed information related to each unit price item requested.

**18. COMMENCEMENT AND COMPLETION**

- A. Successful Bidder shall commence work when schedule and weather permit, but no later than stated in Bid Form. Contractor shall pursue the Work regularly and continuously at reasonable rate to insure completion of the Work within time stated in Bid.
- B. Should it be found impossible to complete the Work on or before time specified for completion, written request may be submitted for extension of time setting forth reasons believed to justify granting of such request. Refer to Article 20 of General Conditions of Contract, titled "Time for Completion".

**19. WORK BY OWNER**

- A. Not Applicable.

**20. SPECIAL HAZARDS COVERAGE**

- A. Not Applicable.

**FORM A**

**DANE COUNTY  
EMERGING SMALL BUSINESS REPORT - CERTIFICATION**

In accordance with General Conditions of Contract, submit this Emerging Small Business Report within ten (10) days after Bid Due Date.

PROJECT NAME: \_\_\_\_\_

\_\_\_\_\_

BID NO.: \_\_\_\_\_ BID DUE DATE: \_\_\_\_\_

**BIDDER INFORMATION**

COMPANY NAME: \_\_\_\_\_

ADDRESS: \_\_\_\_\_

\_\_\_\_\_

TELEPHONE NO.: \_\_\_\_\_

CONTACT PERSON: \_\_\_\_\_

EMAIL ADDRESS: \_\_\_\_\_

**FORM B**

Page \_\_\_ of \_\_\_

**DANE COUNTY**

(Copy this Form as necessary to provide complete information)

**EMERGING SMALL BUSINESS REPORT - INVOLVEMENT**

COMPANY NAME: \_\_\_\_\_

PROJECT NAME: \_\_\_\_\_

BID NO.: \_\_\_\_\_ BID DUE DATE: \_\_\_\_\_

ESB NAME: \_\_\_\_\_

CONTACT PERSON: \_\_\_\_\_

ADDRESS: \_\_\_\_\_

PHONE NO & EMAIL.: \_\_\_\_\_

Indicate percentage of financial commitment to this ESB: \_\_\_\_\_ % Amount: \$ \_\_\_\_\_

ESB NAME: \_\_\_\_\_

CONTACT PERSON: \_\_\_\_\_

ADDRESS: \_\_\_\_\_

PHONE NO & EMAIL.: \_\_\_\_\_

Indicate percentage of financial commitment to this ESB: \_\_\_\_\_ % Amount: \$ \_\_\_\_\_

**FORM C**

Page \_\_\_ of \_\_\_

**DANE COUNTY  
EMERGING SMALL BUSINESS REPORT - CONTACTS**

(Copy this Form as necessary to provide complete information)

COMPANY NAME: \_\_\_\_\_

PROJECT NAME: \_\_\_\_\_

BID NO.: \_\_\_\_\_ BID DUE DATE: \_\_\_\_\_

	<u>ESB FIRM NAME CONTACTED</u>	<u>DATE</u>	<u>PERSON CONTACTED</u>	<u>DID ESB BID?</u>	<u>ACC- EPT BID?</u>	<u>REASON FOR REJECTION</u>
1)	_____	_____	_____	_____	_____	_____
2)	_____	_____	_____	_____	_____	_____
3)	_____	_____	_____	_____	_____	_____
4)	_____	_____	_____	_____	_____	_____
5)	_____	_____	_____	_____	_____	_____
6)	_____	_____	_____	_____	_____	_____
7)	_____	_____	_____	_____	_____	_____
8)	_____	_____	_____	_____	_____	_____

**FORM D**

**DANE COUNTY  
EMERGING SMALL BUSINESS REPORT - CERTIFICATION STATEMENT**

I, \_\_\_\_\_, \_\_\_\_\_ of  
Name Title

\_\_\_\_\_ certify to best of my knowledge and  
Company

belief that this business meets Emerging Small Business definition as indicated in Article 9 and  
that information contained in this Emerging Small Business Report is true and correct.

\_\_\_\_\_  
Bidder's Signature

\_\_\_\_\_  
Date

Name of Bidding Firm: \_\_\_\_\_

**BID FORM**

**BID NO. 318045**

**PROJECT: JOB CENTER RESTROOM EXPANSION  
DANE COUNTY JOB CENTER**

**TO: DANE COUNTY DEPARTMENT OF PUBLIC WORKS, HIGHWAY &  
TRANSPORTATION PROJECT MANAGER  
1919 ALLIANT ENERGY CENTER WAY  
MADISON, WISCONSIN 53713**

**NOTE: WISCONSIN STATUTE 77.54 (9M) ALLOWS FOR NO SALES & USE TAX ON  
THE PURCHASE OF MATERIALS FOR COUNTY PUBLIC WORKS PROJECTS.**

**BASE BID - LUMP SUM:**

Dane County is inviting bids for construction services to renovate the restrooms in the Dane County Job Center. The undersigned, having examined the site where the Work is to be executed and having become familiar with local conditions affecting the cost of the Work and having carefully examined the Drawings and Specifications, all other Construction Documents and Addenda thereto prepared by Dane County Department of Public Works, Highway & Transportation hereby agrees to provide all labor, materials, equipment and services necessary for the complete and satisfactory execution of the entire Work, as specified in the Construction Documents, for the Base Bid stipulated sum of:

\_\_\_\_\_ and \_\_\_\_\_ /100 Dollars  
Written Price

\$ \_\_\_\_\_  
Numeric Price

Receipt of the following addenda and inclusion of their provisions in this Bid is hereby acknowledged:

Addendum No(s). \_\_\_\_\_ through \_\_\_\_\_

Dated \_\_\_\_\_

Dane County Human Services must have this project completed by October 28, 2019. Assuming this Work can be started by April 2, 2019, what dates can you commence and complete this job?

Commencement Date: \_\_\_\_\_ Completion Date: \_\_\_\_\_  
(final, not substantial)

I hereby certify that all statements herein are made on behalf of:

\_\_\_\_\_  
(Name of Corporation, Partnership or Person submitting Bid)

Select one of the following:

1. A corporation organized and existing under the laws of the State of \_\_\_\_\_, or
2. A partnership consisting of \_\_\_\_\_, or
3. A person conducting business as \_\_\_\_\_;

Of the City, Village, or Town of \_\_\_\_\_ of the State of \_\_\_\_\_.

I have examined and carefully prepared this Bid from the associated Construction Documents and have checked the same in detail before submitting this Bid; that I have full authority to make such statements and submit this Bid in (its) (their) (my) behalf; and that the said statements are true and correct. In signing this Bid, we also certify that we have not, either directly or indirectly, entered into any agreement or participated in any collusion or otherwise taken any action in restraint of free competition; that no attempt has been made to induce any other person or firm to submit or not to submit a Bid; that this Bid has been independently arrived at without collusion with any other bidder, competitor, or potential competitor; that this Bid has not been knowingly disclosed prior to the Bids Due Date to another bidder or competitor; that the above statement is accurate under penalty of perjury.

The undersigned further agrees to honor the Base Bid and the Alternate Bid(s) for sixty (60) calendar days from date of Award of Contract.

**SIGNATURE:** \_\_\_\_\_  
(Bid is invalid without signature)

Print Name: \_\_\_\_\_ Date: \_\_\_\_\_

Title: \_\_\_\_\_

Address: \_\_\_\_\_

Telephone No.: \_\_\_\_\_ Fax No.: \_\_\_\_\_

Email Address: \_\_\_\_\_

Contact Person: \_\_\_\_\_

**THIS PAGE IS FOR BIDDERS' REFERENCE AND NEED NOT BE SUBMITTED WITH BID FORM.**

**BID CHECK LIST:**

These items **must** be included with Bid:

Bid Form

Bid Bond

Fair Labor Practices Certification

**BIDDERS SHOULD BE AWARE OF THE FOLLOWING:**

**DANE COUNTY VENDOR REGISTRATION PROGRAM**

All bidders are strongly encouraged to be a registered vendor with Dane County. Registering allows vendors an opportunity to receive notifications for RFBs & RFPs issued by the County and provides the County with up-to-date company contact information. Complete a new form or renewal online at:

[danepurchasing.com/Account/Login?](http://danepurchasing.com/Account/Login?)

**DANE COUNTY BEST VALUE CONTRACTING PRE-QUALIFICATION**

Contractors must be pre-qualified as a Best Value Contractor with the Dane County Public Works Engineering Division before the award of contract. Obtain a *Best Value Contracting Application* by calling 608/266-4018 or complete one online at:

[countyofdane.com/pwht/BVC\\_Application.aspx](http://countyofdane.com/pwht/BVC_Application.aspx)



**FAIR LABOR PRACTICES CERTIFICATION**

The undersigned, for and on behalf of the BIDDER, APPLICANT or PROPOSER named herein, certifies as follows:

- A. That he or she is an officer or duly authorized agent of the above-referenced BIDDER, APPLICANT or PROPOSER, which has submitted a bid, application or proposal for a contract or agreement with the county of Dane.
  
- B. That BIDDER, APPLICANT or PROPOSER has (check one):

\_\_\_\_\_ not been found by the National Labor Relations Board (“NLRB”) or the Wisconsin Employment Relations Commission (“WERC”) to have violated any statute or regulation regarding labor standards or relations in the seven years prior to the signature date of this Certification.

\_\_\_\_\_ been found by the National Labor Relations Board (“NLRB”) or the Wisconsin Employment Relations Commission (“WERC”) to have violated any statute or regulation regarding labor standards or relations in the seven years prior to the signature date of this Certification.

\_\_\_\_\_  
Officer or Authorized Agent Signature Date

\_\_\_\_\_  
Printed or Typed Name and Title

\_\_\_\_\_  
Printed or Typed Business Name

**NOTE:** You can find information regarding the violations described above at: [www.nlrb.gov](http://www.nlrb.gov) and [werc.wi.gov](http://werc.wi.gov).

For reference, Dane County Ordinance 25.09 is as follows:

- (1) BIDDER RESPONSIBILITY. (a) Any bid, application or proposal for any contract with the county, including public works contracts regulated under chapter 40, shall include a certification indicating whether the bidder has been found by the National Labor Relations Board (NLRB) or the Wisconsin Employment Relations Committee (WERC) to have violated any statute or regulation regarding labor standards or relations within the last seven years. The Controller shall investigate any such finding and make a recommendation to the committee, which shall determine whether the conduct resulting in the finding affects the bidder’s responsibility to perform the contract.

**If you indicated that the NLRB or WERC have found you to have such a violation, you must include copies of any relevant information regarding such violation with your proposal, bid or application.**

Include this completed Certification with your bid, application or proposal.

**COUNTY OF DANE**

**PUBLIC WORKS CONSTRUCTION CONTRACT**

Contract No. \_\_\_\_\_ Bid No. 318045

Authority: 2018 RES - \_\_\_\_\_

**THIS CONTRACT**, made and entered into as of the date by which authorized representatives of both parties have affixed their signatures, by and between the County of Dane (hereafter referred to as "COUNTY") and \_\_\_\_\_ (hereafter, "CONTRACTOR"), and

**WITNESSETH:**

**WHEREAS**, COUNTY, whose address is c/o Public Works Director, 1919 Alliant Energy Center Way, Madison, WI 53713, desires to have CONTRACTOR provide Job Center Restroom Expansion at the Dane County Job Center ("the Project"); and

**WHEREAS**, CONTRACTOR, whose address is \_\_\_\_\_ is able and willing to construct the Project, in accordance with the Construction Documents;

**NOW, THEREFORE**, in consideration of the above premises and the mutual covenants of the parties hereinafter set forth, the receipt and sufficiency of which is acknowledged by each party for itself, COUNTY and CONTRACTOR do agree as follows:

1. CONTRACTOR agrees to construct, for the price of \$ \_\_\_\_\_ the Project and at the CONTRACTOR'S own proper cost and expense to furnish all materials, supplies, machinery, equipment, tools, superintendence labor, insurance, and other accessories and services necessary to complete the Project in accordance with the conditions and prices stated in the Bid Form, General Conditions of Contract, the drawings which include all maps, plats, plans, and other drawings and printed or written explanatory matter thereof, and the specifications therefore as prepared by \_\_\_\_\_ (hereinafter referred to as "the Architect / Engineer"), and as enumerated in the Project Manual Table of Contents, all of which are made a part hereof and collectively evidence and constitute the Contract.
2. COUNTY agrees to pay the CONTRACTOR in current funds for the performance of the Contract subject to additions and deductions, as provided in the General Conditions of Contract, and to make payments on account thereof as provided in Article entitled, "Payments to Contractor" of the General Conditions of Contract.
3. NOT USED.
4. CONTRACTOR shall file an Affirmative Action Plan with the Dane County Contract Compliance Officer in accord with Chapter 19 of the Dane County Code of Ordinances. CONTRACTOR must file such plan within fifteen (15) business days of the effective date of this Contract. During the term of this Contract CONTRACTOR shall also provide copies of all announcements of employment opportunities to COUNTY'S Contract Compliance Office, and

shall report annually the number of persons, by race, ethnicity, gender, and disability status, which apply for employment and, similarly classified, the number hired and number rejected.

- 5.** During the term of this Contract, all solicitations for employment placed on CONTRACTOR'S behalf shall include a statement to the effect that CONTRACTOR is an "Equal Opportunity Employer".
- 6.** CONTRACTOR agrees to furnish all information and reports required by COUNTY'S Contract Compliance Officer as the same relate to affirmative action and nondiscrimination, which may include any books, records, or accounts deemed appropriate to determine compliance with Chapter 19, Dane County Code of Ordinances, and the provisions of this Contract.
- 7.** This Contract is intended to be a Contract solely between the parties hereto and for their benefit only. No part of this Contract shall be construed to add to, supplement, amend, abridge or repeal existing rights, benefits or privileges of any third party or parties including, but not limited to, employees of either of the parties.
- 8.** The entire agreement of the parties is contained herein and this Contract supersedes any and all oral agreements and negotiations between the parties relating to the subject matter hereof. The parties expressly agree that the express terms of this Contract shall not be amended in any fashion except in writing, executed by both parties.
- 9.** CONTRACTOR must be pre-qualified as a Best Value Contractor with Dane County Public Works Engineering Division before award of Contract. Subcontractors must be pre-qualified ten (10) business days prior to commencing Work under this Contract.

**IN WITNESS WHEREOF**, COUNTY and CONTRACTOR, by their respective authorized agents, have caused this Contract and its Schedules to be executed, effective as of the date by which all parties hereto have affixed their respective signatures, as indicated below.

\* \* \* \* \*

**FOR CONTRACTOR:**

\_\_\_\_\_  
Signature Date

\_\_\_\_\_  
Printed or Typed Name and Title

\_\_\_\_\_  
Signature Date

\_\_\_\_\_  
Printed or Typed Name and Title

**NOTE:** If CONTRACTOR is a corporation, Secretary should attest. In accordance with IRS Regulations, unincorporated entities are required to provide either their Social Security or Employer Number in order to receive payment for services rendered.

\* \* \* \* \*

This Contract is not valid or effectual for any purpose until approved by the appropriate authority designated below, and no work is authorized until the CONTRACTOR has been given notice to proceed by COUNTY'S Assistant Public Works Director.

**FOR COUNTY:**

\_\_\_\_\_  
Joseph T. Parisi, County Executive Date

\_\_\_\_\_  
Scott McDonell, County Clerk Date

# AIA<sup>®</sup> Document A310<sup>™</sup> – 2010

## Bid Bond

**CONTRACTOR:**

(Name, legal status and address)

**SURETY:**

(Name, legal status and principal place of business)

**OWNER:**

(Name, legal status and address)

**BOND AMOUNT:****PROJECT:**

(Name, location or address, and Project number, if any)

This document has important legal consequences. Consultation with an attorney is encouraged with respect to its completion or modification.

Any singular reference to Contractor, Surety, Owner or other party shall be considered plural where applicable.

The Contractor and Surety are bound to the Owner in the amount set forth above, for the payment of which the Contractor and Surety bind themselves, their heirs, executors, administrators, successors and assigns, jointly and severally, as provided herein. The conditions of this Bond are such that if the Owner accepts the bid of the Contractor within the time specified in the bid documents, or within such time period as may be agreed to by the Owner and Contractor, and the Contractor either (1) enters into a contract with the Owner in accordance with the terms of such bid, and gives such bond or bonds as may be specified in the bidding or Contract Documents, with a surety admitted in the jurisdiction of the Project and otherwise acceptable to the Owner, for the faithful performance of such Contract and for the prompt payment of labor and material furnished in the prosecution thereof; or (2) pays to the Owner the difference, not to exceed the amount of this Bond, between the amount specified in said bid and such larger amount for which the Owner may in good faith contract with another party to perform the work covered by said bid, then this obligation shall be null and void, otherwise to remain in full force and effect. The Surety hereby waives any notice of an agreement between the Owner and Contractor to extend the time in which the Owner may accept the bid. Waiver of notice by the Surety shall not apply to any extension exceeding sixty (60) days in the aggregate beyond the time for acceptance of bids specified in the bid documents, and the Owner and Contractor shall obtain the Surety's consent for an extension beyond sixty (60) days.

If this Bond is issued in connection with a subcontractor's bid to a Contractor, the term Contractor in this Bond shall be deemed to be Subcontractor and the term Owner shall be deemed to be Contractor.

When this Bond has been furnished to comply with a statutory or other legal requirement in the location of the Project, any provision in this Bond conflicting with said statutory or legal requirement shall be deemed deleted herefrom and provisions conforming to such statutory or other legal requirement shall be deemed incorporated herein. When so furnished, the intent is that this Bond shall be construed as a statutory bond and not as a common law bond.

Signed and sealed this \_\_\_\_\_ day of \_\_\_\_\_

_____	(Contractor as Principal)	_____	(Seal)
(Witness)	_____	_____	(Title)
_____	(Surety)	_____	(Seal)
(Witness)	_____	_____	(Title)

**CAUTION:** You should sign an original AIA Contract Document, on which this text appears in RED. An original assures that changes will not be obscured.

# AIA<sup>®</sup> Document A312<sup>™</sup> – 2010

## Performance Bond

**CONTRACTOR:**

*(Name, legal status and address)*

**SURETY:**

*(Name, legal status and principal place of business)*

**OWNER:**

*(Name, legal status and address)*

This document has important legal consequences. Consultation with an attorney is encouraged with respect to its completion or modification.

Any singular reference to Contractor, Surety, Owner or other party shall be considered plural where applicable.

AIA Document A312–2010 combines two separate bonds, a Performance Bond and a Payment Bond, into one form. This is not a single combined Performance and Payment Bond.

**CONSTRUCTION CONTRACT**

Date:

Amount:

Description:

*(Name and location)*

**BOND**

Date:

*(Not earlier than Construction Contract Date)*

Amount:

Modifications to this Bond:  None  See Section 16

**CONTRACTOR AS PRINCIPAL**

Company: *(Corporate Seal)*

**SURETY**

Company: *(Corporate Seal)*

Signature: \_\_\_\_\_

Name \_\_\_\_\_  
and Title: \_\_\_\_\_

Signature: \_\_\_\_\_

Name \_\_\_\_\_  
and Title: \_\_\_\_\_

*(Any additional signatures appear on the last page of this Performance Bond.)*

*(FOR INFORMATION ONLY — Name, address and telephone)*

**AGENT or BROKER:**

**OWNER'S REPRESENTATIVE:**

*(Architect, Engineer or other party:)*

§ 1 The Contractor and Surety, jointly and severally, bind themselves, their heirs, executors, administrators, successors and assigns to the Owner for the performance of the Construction Contract, which is incorporated herein by reference.

§ 2 If the Contractor performs the Construction Contract, the Surety and the Contractor shall have no obligation under this Bond, except when applicable to participate in a conference as provided in Section 3.

§ 3 If there is no Owner Default under the Construction Contract, the Surety's obligation under this Bond shall arise after

- .1 the Owner first provides notice to the Contractor and the Surety that the Owner is considering declaring a Contractor Default. Such notice shall indicate whether the Owner is requesting a conference among the Owner, Contractor and Surety to discuss the Contractor's performance. If the Owner does not request a conference, the Surety may, within five (5) business days after receipt of the Owner's notice, request such a conference. If the Surety timely requests a conference, the Owner shall attend. Unless the Owner agrees otherwise, any conference requested under this Section 3.1 shall be held within ten (10) business days of the Surety's receipt of the Owner's notice. If the Owner, the Contractor and the Surety agree, the Contractor shall be allowed a reasonable time to perform the Construction Contract, but such an agreement shall not waive the Owner's right, if any, subsequently to declare a Contractor Default;
- .2 the Owner declares a Contractor Default, terminates the Construction Contract and notifies the Surety; and
- .3 the Owner has agreed to pay the Balance of the Contract Price in accordance with the terms of the Construction Contract to the Surety or to a contractor selected to perform the Construction Contract.

§ 4 Failure on the part of the Owner to comply with the notice requirement in Section 3.1 shall not constitute a failure to comply with a condition precedent to the Surety's obligations, or release the Surety from its obligations, except to the extent the Surety demonstrates actual prejudice.

§ 5 When the Owner has satisfied the conditions of Section 3, the Surety shall promptly and at the Surety's expense take one of the following actions:

§ 5.1 Arrange for the Contractor, with the consent of the Owner, to perform and complete the Construction Contract;

§ 5.2 Undertake to perform and complete the Construction Contract itself, through its agents or independent contractors;

§ 5.3 Obtain bids or negotiated proposals from qualified contractors acceptable to the Owner for a contract for performance and completion of the Construction Contract, arrange for a contract to be prepared for execution by the Owner and a contractor selected with the Owner's concurrence, to be secured with performance and payment bonds executed by a qualified surety equivalent to the bonds issued on the Construction Contract, and pay to the Owner the amount of damages as described in Section 7 in excess of the Balance of the Contract Price incurred by the Owner as a result of the Contractor Default; or

§ 5.4 Waive its right to perform and complete, arrange for completion, or obtain a new contractor and with reasonable promptness under the circumstances:

- .1 After investigation, determine the amount for which it may be liable to the Owner and, as soon as practicable after the amount is determined, make payment to the Owner; or
- .2 Deny liability in whole or in part and notify the Owner, citing the reasons for denial.

§ 6 If the Surety does not proceed as provided in Section 5 with reasonable promptness, the Surety shall be deemed to be in default on this Bond seven days after receipt of an additional written notice from the Owner to the Surety demanding that the Surety perform its obligations under this Bond, and the Owner shall be entitled to enforce any remedy available to the Owner. If the Surety proceeds as provided in Section 5.4, and the Owner refuses the payment or the Surety has denied liability, in whole or in part, without further notice the Owner shall be entitled to enforce any remedy available to the Owner.

§ 7 If the Surety elects to act under Section 5.1, 5.2 or 5.3, then the responsibilities of the Surety to the Owner shall not be greater than those of the Contractor under the Construction Contract, and the responsibilities of the Owner to the Surety shall not be greater than those of the Owner under the Construction Contract. Subject to the commitment by the Owner to pay the Balance of the Contract Price, the Surety is obligated, without duplication, for

- .1 the responsibilities of the Contractor for correction of defective work and completion of the Construction Contract;
- .2 additional legal, design professional and delay costs resulting from the Contractor's Default, and resulting from the actions or failure to act of the Surety under Section 5; and
- .3 liquidated damages, or if no liquidated damages are specified in the Construction Contract, actual damages caused by delayed performance or non-performance of the Contractor.

§ 8 If the Surety elects to act under Section 5.1, 5.3 or 5.4, the Surety's liability is limited to the amount of this Bond.

§ 9 The Surety shall not be liable to the Owner or others for obligations of the Contractor that are unrelated to the Construction Contract, and the Balance of the Contract Price shall not be reduced or set off on account of any such unrelated obligations. No right of action shall accrue on this Bond to any person or entity other than the Owner or its heirs, executors, administrators, successors and assigns.

§ 10 The Surety hereby waives notice of any change, including changes of time, to the Construction Contract or to related subcontracts, purchase orders and other obligations.

§ 11 Any proceeding, legal or equitable, under this Bond may be instituted in any court of competent jurisdiction in the location in which the work or part of the work is located and shall be instituted within two years after a declaration of Contractor Default or within two years after the Contractor ceased working or within two years after the Surety refuses or fails to perform its obligations under this Bond, whichever occurs first. If the provisions of this Paragraph are void or prohibited by law, the minimum period of limitation available to sureties as a defense in the jurisdiction of the suit shall be applicable.

§ 12 Notice to the Surety, the Owner or the Contractor shall be mailed or delivered to the address shown on the page on which their signature appears.

§ 13 When this Bond has been furnished to comply with a statutory or other legal requirement in the location where the construction was to be performed, any provision in this Bond conflicting with said statutory or legal requirement shall be deemed deleted herefrom and provisions conforming to such statutory or other legal requirement shall be deemed incorporated herein. When so furnished, the intent is that this Bond shall be construed as a statutory bond and not as a common law bond.

#### § 14 Definitions

§ 14.1 **Balance of the Contract Price.** The total amount payable by the Owner to the Contractor under the Construction Contract after all proper adjustments have been made, including allowance to the Contractor of any amounts received or to be received by the Owner in settlement of insurance or other claims for damages to which the Contractor is entitled, reduced by all valid and proper payments made to or on behalf of the Contractor under the Construction Contract.

§ 14.2 **Construction Contract.** The agreement between the Owner and Contractor identified on the cover page, including all Contract Documents and changes made to the agreement and the Contract Documents.

§ 14.3 **Contractor Default.** Failure of the Contractor, which has not been remedied or waived, to perform or otherwise to comply with a material term of the Construction Contract.

§ 14.4 **Owner Default.** Failure of the Owner, which has not been remedied or waived, to pay the Contractor as required under the Construction Contract or to perform and complete or comply with the other material terms of the Construction Contract.

§ 14.5 **Contract Documents.** All the documents that comprise the agreement between the Owner and Contractor.

§ 15 If this Bond is issued for an agreement between a Contractor and subcontractor, the term Contractor in this Bond shall be deemed to be Subcontractor and the term Owner shall be deemed to be Contractor.



§ 16 Modifications to this bond are as follows:

Sample

*(Space is provided below for additional signatures of added parties, other than those appearing on the cover page.)*

**CONTRACTOR AS PRINCIPAL**

**SURETY**

Company: \_\_\_\_\_

*(Corporate Seal)*

Company: \_\_\_\_\_

*(Corporate Seal)*

Signature: \_\_\_\_\_

Name and Title: \_\_\_\_\_

Address \_\_\_\_\_

Signature: \_\_\_\_\_

Name and Title: \_\_\_\_\_

Address \_\_\_\_\_

**CAUTION: You should sign an original AIA Contract Document, on which this text appears in RED. An original assures that changes will not be obscured.**



# AIA® Document A312™ – 2010

## Payment Bond

**CONTRACTOR:**

*(Name, legal status and address)*

**SURETY:**

*(Name, legal status and principal place of business)*

**OWNER:**

*(Name, legal status and address)*

This document has important legal consequences. Consultation with an attorney is encouraged with respect to its completion or modification.

Any singular reference to Contractor, Surety, Owner or other party shall be considered plural where applicable.

AIA Document A312-2010 combines two separate bonds, a Performance Bond and a Payment Bond, into one form. This is not a single combined Performance and Payment Bond.

**CONSTRUCTION CONTRACT**

Date:

Amount:

Description:

*(Name and location)*

**BOND**

Date:

*(Not earlier than Construction Contract Date)*

Amount:

Modifications to this Bond:  None  See Section 18

**CONTRACTOR AS PRINCIPAL**

Company: *(Corporate Seal)*

**SURETY**

Company: *(Corporate Seal)*

Signature: \_\_\_\_\_

Name \_\_\_\_\_  
and Title: \_\_\_\_\_

Signature: \_\_\_\_\_

Name \_\_\_\_\_  
and Title: \_\_\_\_\_

*(Any additional signatures appear on the last page of this Payment Bond.)*

*(FOR INFORMATION ONLY — Name, address and telephone)*

**AGENT or BROKER:****OWNER'S REPRESENTATIVE:**

*(Architect, Engineer or other party:)*

§ 1 The Contractor and Surety, jointly and severally, bind themselves, their heirs, executors, administrators, successors and assigns to the Owner to pay for labor, materials and equipment furnished for use in the performance of the Construction Contract, which is incorporated herein by reference, subject to the following terms.

§ 2 If the Contractor promptly makes payment of all sums due to Claimants, and defends, indemnifies and holds harmless the Owner from claims, demands, liens or suits by any person or entity seeking payment for labor, materials or equipment furnished for use in the performance of the Construction Contract, then the Surety and the Contractor shall have no obligation under this Bond.

§ 3 If there is no Owner Default under the Construction Contract, the Surety's obligation to the Owner under this Bond shall arise after the Owner has promptly notified the Contractor and the Surety (at the address described in Section 13) of claims, demands, liens or suits against the Owner or the Owner's property by any person or entity seeking payment for labor, materials or equipment furnished for use in the performance of the Construction Contract and tendered defense of such claims, demands, liens or suits to the Contractor and the Surety.

§ 4 When the Owner has satisfied the conditions in Section 3, the Surety shall promptly and at the Surety's expense defend, indemnify and hold harmless the Owner against a duly tendered claim, demand, lien or suit.

§ 5 The Surety's obligations to a Claimant under this Bond shall arise after the following:

§ 5.1 Claimants, who do not have a direct contract with the Contractor,

- .1 have furnished a written notice of non-payment to the Contractor, stating with substantial accuracy the amount claimed and the name of the party to whom the materials were, or equipment was, furnished or supplied or for whom the labor was done or performed, within ninety (90) days after having last performed labor or last furnished materials or equipment included in the Claim; and
- .2 have sent a Claim to the Surety (at the address described in Section 13).

§ 5.2 Claimants, who are employed by or have a direct contract with the Contractor, have sent a Claim to the Surety (at the address described in Section 13).

§ 6 If a notice of non-payment required by Section 5.1.1 is given by the Owner to the Contractor, that is sufficient to satisfy a Claimant's obligation to furnish a written notice of non-payment under Section 5.1.1.

§ 7 When a Claimant has satisfied the conditions of Sections 5.1 or 5.2, whichever is applicable, the Surety shall promptly and at the Surety's expense take the following actions:

§ 7.1 Send an answer to the Claimant, with a copy to the Owner, within sixty (60) days after receipt of the Claim, stating the amounts that are undisputed and the basis for challenging any amounts that are disputed; and

§ 7.2 Pay or arrange for payment of any undisputed amounts.

§ 7.3 The Surety's failure to discharge its obligations under Section 7.1 or Section 7.2 shall not be deemed to constitute a waiver of defenses the Surety or Contractor may have or acquire as to a Claim, except as to undisputed amounts for which the Surety and Claimant have reached agreement. If, however, the Surety fails to discharge its obligations under Section 7.1 or Section 7.2, the Surety shall indemnify the Claimant for the reasonable attorney's fees the Claimant incurs thereafter to recover any sums found to be due and owing to the Claimant.

§ 8 The Surety's total obligation shall not exceed the amount of this Bond, plus the amount of reasonable attorney's fees provided under Section 7.3, and the amount of this Bond shall be credited for any payments made in good faith by the Surety.

§ 9 Amounts owed by the Owner to the Contractor under the Construction Contract shall be used for the performance of the Construction Contract and to satisfy claims, if any, under any construction performance bond. By the Contractor furnishing and the Owner accepting this Bond, they agree that all funds earned by the Contractor in the performance of the Construction Contract are dedicated to satisfy obligations of the Contractor and Surety under this Bond, subject to the Owner's priority to use the funds for the completion of the work.

§ 10 The Surety shall not be liable to the Owner, Claimants or others for obligations of the Contractor that are unrelated to the Construction Contract. The Owner shall not be liable for the payment of any costs or expenses of any Claimant under this Bond, and shall have under this Bond no obligation to make payments to, or give notice on behalf of, Claimants or otherwise have any obligations to Claimants under this Bond.

§ 11 The Surety hereby waives notice of any change, including changes of time, to the Construction Contract or to related subcontracts, purchase orders and other obligations.

§ 12 No suit or action shall be commenced by a Claimant under this Bond other than in a court of competent jurisdiction in the state in which the project that is the subject of the Construction Contract is located or after the expiration of one year from the date (1) on which the Claimant sent a Claim to the Surety pursuant to Section 5.1.2 or 5.2, or (2) on which the last labor or service was performed by anyone or the last materials or equipment were furnished by anyone under the Construction Contract, whichever of (1) or (2) first occurs. If the provisions of this Paragraph are void or prohibited by law, the minimum period of limitation available to sureties as a defense in the jurisdiction of the suit shall be applicable.

§ 13 Notice and Claims to the Surety, the Owner or the Contractor shall be mailed or delivered to the address shown on the page on which their signature appears. Actual receipt of notice or Claims, however accomplished, shall be sufficient compliance as of the date received.

§ 14 When this Bond has been furnished to comply with a statutory or other legal requirement in the location where the construction was to be performed, any provision in this Bond conflicting with said statutory or legal requirement shall be deemed deleted herefrom and provisions conforming to such statutory or other legal requirement shall be deemed incorporated herein. When so furnished, the intent is that this Bond shall be construed as a statutory bond and not as a common law bond.

§ 15 Upon request by any person or entity appearing to be a potential beneficiary of this Bond, the Contractor and Owner shall promptly furnish a copy of this Bond or shall permit a copy to be made.

#### § 16 Definitions

§ 16.1 Claim. A written statement by the Claimant including at a minimum:

- .1 the name of the Claimant;
- .2 the name of the person for whom the labor was done, or materials or equipment furnished;
- .3 a copy of the agreement or purchase order pursuant to which labor, materials or equipment was furnished for use in the performance of the Construction Contract;
- .4 a brief description of the labor, materials or equipment furnished;
- .5 the date on which the Claimant last performed labor or last furnished materials or equipment for use in the performance of the Construction Contract;
- .6 the total amount earned by the Claimant for labor, materials or equipment furnished as of the date of the Claim;
- .7 the total amount of previous payments received by the Claimant; and
- .8 the total amount due and unpaid to the Claimant for labor, materials or equipment furnished as of the date of the Claim.

§ 16.2 Claimant. An individual or entity having a direct contract with the Contractor or with a subcontractor of the Contractor to furnish labor, materials or equipment for use in the performance of the Construction Contract. The term Claimant also includes any individual or entity that has rightfully asserted a claim under an applicable mechanic's lien or similar statute against the real property upon which the Project is located. The intent of this Bond shall be to include without limitation in the terms "labor, materials or equipment" that part of water, gas, power, light, heat, oil, gasoline, telephone service or rental equipment used in the Construction Contract, architectural and engineering services required for performance of the work of the Contractor and the Contractor's subcontractors, and all other items for which a mechanic's lien may be asserted in the jurisdiction where the labor, materials or equipment were furnished.

§ 16.3 Construction Contract. The agreement between the Owner and Contractor identified on the cover page, including all Contract Documents and all changes made to the agreement and the Contract Documents.

§ 16.4 **Owner Default.** Failure of the Owner, which has not been remedied or waived, to pay the Contractor as required under the Construction Contract or to perform and complete or comply with the other material terms of the Construction Contract.

§ 16.5 **Contract Documents.** All the documents that comprise the agreement between the Owner and Contractor.

§ 17 If this Bond is issued for an agreement between a Contractor and subcontractor, the term Contractor in this Bond shall be deemed to be Subcontractor and the term Owner shall be deemed to be Contractor.

§ 18 Modifications to this bond are as follows:

*(Space is provided below for additional signatures of added parties, other than those appearing on the cover page.)*

**CONTRACTOR AS PRINCIPAL**

Company: \_\_\_\_\_

(Corporate Seal)

**SURETY**

Company: \_\_\_\_\_

(Corporate Seal)

Signature: \_\_\_\_\_

Name and Title: \_\_\_\_\_

Address \_\_\_\_\_

Signature: \_\_\_\_\_

Name and Title: \_\_\_\_\_

Address \_\_\_\_\_

**CAUTION: You should sign an original AIA Contract Document, on which this text appears in RED. An original assures that changes will not be obscured.**

## GENERAL CONDITIONS OF CONTRACT

### TABLE OF CONTENTS

1. CONSTRUCTION DOCUMENTS .....	2
2. DEFINITIONS .....	2
3. ADDITIONAL INSTRUCTIONS AND DRAWINGS .....	2
4. SHOP DRAWINGS, PRODUCT DATA AND SAMPLES .....	3
5. CUTTING AND PATCHING.....	4
6. CLEANING UP .....	4
7. USE OF SITE.....	4
8. MATERIALS AND WORKMANSHIP .....	5
9. CONTRACTOR'S TITLE TO MATERIALS .....	5
10. "OR EQUAL" CLAUSE.....	5
11. PATENTS AND ROYALTIES.....	6
12. SURVEYS, PERMITS, REGULATIONS AND TAXES.....	7
13. CONTRACTOR'S OBLIGATIONS AND SUPERINTENDENCE.....	7
14. WEATHER CONDITIONS .....	8
15. PROTECTION OF WORK AND PROPERTY .....	8
16. INSPECTION AND TESTING OF MATERIALS .....	8
17. REPORTS, RECORDS AND DATA .....	9
18. CHANGES IN THE WORK .....	9
19. EXTRAS .....	10
20. TIME FOR COMPLETION.....	10
21. CORRECTION OF WORK.....	10
22. SUBSURFACE CONDITIONS FOUND DIFFERENT .....	11
23. RIGHT OF DEPARTMENT TO TERMINATE CONTRACT .....	11
24. CONSTRUCTION SCHEDULE AND PERIODIC ESTIMATES .....	11
25. PAYMENTS TO CONTRACTOR .....	12
26. WITHHOLDING OF PAYMENTS.....	13
27. ACCEPTANCE OF FINAL PAYMENT AS RELEASE .....	14
28. PAYMENTS BY CONTRACTOR.....	14
29. CONTRACT SECURITY .....	14
30. ASSIGNMENTS.....	14
31. MUTUAL RESPONSIBILITY OF CONTRACTORS .....	15
32. SEPARATE CONTRACTS .....	15
33. SUBCONTRACTS .....	15
34. PUBLIC WORKS PROJECT MANAGER'S AUTHORITY .....	16
35. ARCHITECT / ENGINEER'S AUTHORITY .....	16
36. STATED ALLOWANCES .....	16
37. ESTIMATES OF QUANTITIES .....	17
38. LANDS AND RIGHTS-OF-WAY .....	17
39. GENERAL GUARANTEE.....	18
40. CONFLICTING CONDITIONS .....	18
41. NOTICE AND SERVICE THEREOF .....	18
42. PROTECTION OF LIVES AND HEALTH .....	19
43. AFFIRMATIVE ACTION PROVISION AND MINORITY / WOMEN / DISADVANTAGED BUSINESS ENTERPRISES .....	19
44. COMPLIANCE WITH FAIR LABOR STANDARDS .....	20
45. DOMESTIC PARTNERSHIP BENEFITS .....	20
46. USE AND OCCUPANCY PRIOR TO ACCEPTANCE .....	20
47. MINIMUM WAGES .....	20
48. CLAIMS .....	20
49. ANTITRUST AGREEMENT .....	21
50. INSURANCE.....	21
51. WISCONSIN LAW CONTROLLING .....	23

## **1. CONSTRUCTION DOCUMENTS**

- A. Construction Documents, listed in Table of Contents of this Specification volume shall form part of this Contract and provisions of Construction Documents shall be as binding upon parties as if they were fully set forth in Contract itself.
- B. These shall also be considered as part of Construction Documents: Addenda, including additions and modifications incorporated in such addenda before execution of Contract; requests for information; construction bulletins; change orders; and written interpretations by Architect / Engineer or Public Works Project Manager that are made after execution of Contract.
- C. Construction Documents are complementary, and what is required by one shall be as binding as if required by all. Intent of Construction Documents is to include all labor, materials and equipment necessary for proper execution of the Work.

## **2. DEFINITIONS**

- A. These terms as used in this Contract are respectively defined as follows:
  - 1. All uses of term “County” in Construction Documents shall mean Dane County.
  - 2. All uses of term “Department” in Construction Documents shall mean Department of Public Works, Highway & Transportation, which is a unit of Dane County government. Department is County agency overseeing Contract with Contractor.
  - 3. Public Works Project Manager is appointed by and responsible to Department. Public Works Project Manager has authority to act on behalf of Department and will sign change orders, payment requests and other administrative matters related to projects.
  - 4. Public Works Project Manager is responsible for supervision, administration and management of field operations involved in construction phase of this Work.
  - 5. Term “Work” includes all labor, equipment and materials necessary to produce project required by Construction Documents.
  - 6. Term “Substantial Completion” is date when project or specified area of project is certified by Architect / Engineer that construction is sufficiently completed, in accordance with Construction Documents, and as modified by any subsequent changes agreed to by parties, so that County may occupy project or specified area of project for use for which it was intended subject to permit approval for occupancy.
  - 7. Contractor is person, firm, or corporation with whom County makes Contract. Though multiple contracts may be involved, Construction Documents treat them throughout as if each were of singular number.

## **3. ADDITIONAL INSTRUCTIONS AND DRAWINGS**

- A. Contractor may be furnished additional instructions and detail drawings as necessary to carry out the Work included in Contract. Additional drawings and instructions thus supplied to Contractor will coordinate with Construction Documents and will be so prepared that they can be reasonably interpreted as part thereof. Contractor shall carry out the Work in accordance with additional detail drawings and instructions.

#### **4. SHOP DRAWINGS, PRODUCT DATA AND SAMPLES**

- A. Unless otherwise specified, Contractor shall submit three (3) copies of all Shop Drawings for each submission, until receiving final approval. After final approval, provide five (5) additional copies for distribution and such other copies as may be required.
- B. Contractor shall submit, on an on-going basis and as directed, Product Data such as brochures that shall contain catalog cuts and specifications of all furnished mechanical and electrical equipment. After Architect / Engineer's approval, one (1) copy shall remain in Architect / Engineer's file, one (1) kept at Department's office and one (1) kept at job site by Contractor for reference purposes.
- C. Samples shall consist of physical examples furnished by Contractor in sufficient size and quantity to illustrate materials, equipment or workmanship, and to establish standards to compare the Work.
  - 1. Submit Samples in sufficient quantity (minimum of two (2)) to permit Architect / Engineer to make all necessary tests and of adequate size showing quality, type, color range, finish, and texture. Label each Sample stating material, type, color, thickness, size, project name, and Contractor's name.
  - 2. Submit transmittal letter requesting approval, and prepay transportation charges to Architect / Engineer's office on samples forwarded.
  - 3. Materials installed shall match approved Samples.
- D. Contractor shall review Shop Drawings and place their dated stamp thereon to evidence their review and approval and shall submit with reasonable promptness and in orderly sequence to cause no delay in the Work or in work of any other contractor. At time of submission, Contractor shall inform Architect / Engineer in writing of any deviation in Shop Drawings or Samples from requirements of Construction Documents. Architect / Engineer will not consider partial lists.
- E. Architect / Engineer will review and approve or reject Shop Drawings with reasonable promptness to cause no delay. Architect / Engineer's approval shall not relieve Contractor from responsibility for errors or omissions in Shop Drawings.
- F. Contractor shall not commence any work requiring Shop Drawing, Product Data or Sample submission until Architect / Engineer has approved submission. All such work shall be in accordance with approved Shop Drawings, Product Data and Samples.
- G. Contractor shall keep on site of the Work, approved or conformed copy of Shop Drawings and shall at all times give Department access thereto.
- H. By stamping and submitting Shop Drawings, Product Data and Samples, Contractor thereby represents that he or she has or will determine and verify all field measurements, field construction criteria, materials, catalog numbers, and similar data and that he or she has checked and coordinated each Shop Drawing, Product Data and Sample with requirements of the Work and of Construction Documents. Architect / Engineer shall return without examination, Shop Drawings, Product Data and Samples not so noted.
- I. All Shop Drawings from any one Contractor should be numbered consecutively and on cover sheet shall bear name and location of project, name of Contractor, date of submittal and date of each correction or revision and associated Specification section and page number.



## **5. CUTTING AND PATCHING**

- A. Contractor shall be responsible for all cutting, fitting or patching required to complete the Work or to make its parts fit together properly.
- B. Contractor shall not damage or endanger portion of the Work or fully or partially completed construction of County or separate contractors by cutting, patching or otherwise altering such construction, or by excavation. Contractor shall not cut or otherwise alter such construction by County or separate contractor except with written consent of County and of such separate contractor; such consent shall not be unreasonably withheld. Contractor shall not withhold unreasonably from County or separate contractor, Contractor's consent to cutting or otherwise altering the Work.

## **6. CLEANING UP**

- A. Contractor shall keep premises and surrounding area free from accumulation of waste materials or rubbish caused by operations under Contract. Contractor shall remove from and about the Work waste materials, rubbish, Contractor's tools, construction equipment, machinery, and surplus materials at completion of the Work. Contractor shall maintain streets and sidewalks around the Work site in clean condition. Contractor shall remove all spillage and prevent tracking of spillage arising from performance of the Work, into, out of, and within the Work site. Contractor shall establish regular maintenance program of sweeping, vacuuming and / or hosing to minimize accumulation of dirt and dust upon such areas.
- B. If Contractor fails to clean up as directed in Construction Documents, County may do so and shall charge Contractor cost thereof.
- C. Contractor shall be responsible for broken windows and glass, and at completion of the Work shall replace such damaged or broken windows and glass. After replacing damaged or broken windows and glass, Contractor shall remove all labels, wash and polish both sides of all windows and glass.
- D. In addition to general cleaning (sweeping, vacuuming and / or hosing, as is appropriate to work surface), Contractor shall perform following final cleaning for all trades at completion of the Work:
  - 1. Remove temporary protections;
  - 2. Remove marks, stains, fingerprints and other soil or dirt from painted, decorated and finished woodwork and wall surfaces;
  - 3. Remove spots, plaster, soil and paint from ceramic tile, marble and other finished materials, and wash or wipe clean;
  - 4. Clean fixtures, cabinet work and equipment, removing stains, paint, dirt and dust, and leave same in undamaged, new condition;
  - 5. Clean aluminum in accordance with recommendations of manufacturer; and
  - 6. Clean resilient floors thoroughly with well-rinsed mop containing only enough moisture to clean off any surface dirt or dust and buff dry by machine to bring surfaces to sheen.

## **7. USE OF SITE**

- A. Contractor shall provide County and Architect / Engineer access to the Work under all circumstances.

- B. Contractor shall confine operations at site to areas permitted by County, law, ordinance, permits and Construction Documents and shall not unreasonably encumber site with materials or equipment. Contractor shall assure free, convenient, unencumbered, direct and safe access to all properties adjacent to the Work for County, its employees, invitees and guests.

## **8. MATERIALS AND WORKMANSHIP**

- A. Contractor shall perform all work and furnish all supplies and materials, machinery, equipment, facilities and means, necessary to complete the Work required by this Contract, within time specified, in accordance with provisions of Construction Documents.
- B. All equipment and materials incorporated in the Work covered by this Contract are to be new; use recycled and / or recovered materials to extent that such use is technically and economically feasible. Recovered materials are products recovered from solid waste in form identical to original form for use that is same as, or similar to original use. Recycled materials are products manufactured from solid waste.
- C. If requested, Contractor shall furnish satisfactory evidence as to kind and quality of construction materials proposed or used. Contractor shall furnish to Architect / Engineer, for approval, manufacturer name and model, performance capacities and other pertinent information of machinery, mechanical, electrical or other types of equipment, which Contractor plans to install.
- D. If not otherwise provided, materials and labor called for in this Contract shall be provided and performed in accordance with established practice and standards recognized by Architects, Engineers, Department, and construction industry.
- E. Reference to "Standard" specifications of any association or manufacturer, or codes of County authorities, intends most recent printed edition or catalog in effect on date that corresponds with date of Construction Documents.
- F. Whenever reference is made in Specifications that work shall be "performed", "applied", in accordance with "manufacturer's directions or instructions", Contractor to whom those instructions are directed shall furnish three (3) printed copies of such instructions to Architect / Engineer before execution of the Work.

## **9. CONTRACTOR'S TITLE TO MATERIALS**

- A. Contractor or any subcontractor shall not purchase materials or supplies for the Work subject to any chattel mortgage or under conditional sale contract or other agreement by which seller retains interest. Contractor warrants that all materials and supplies used in the Work are free from all liens, claims or encumbrances and Contractor has good title to them.

## **10. "OR EQUAL" CLAUSE**

- A. Whenever equipment or materials are identified on Drawings or in Specifications by reference to manufacturer's or vendor's name, trade name, catalog number, and other identifying information, it is intended to establish standards; and any equipment or material of other manufacturers and vendors which will perform adequately duties imposed by general design will be considered equally accepted provided equipment or material so proposed is, in opinion of Architect / Engineer, of equal substance and function. Architect / Engineer and Department shall provide written approval before Contractor may purchase or install it.

- B. Equipment or materials of manufacturers, other than those named, may be used only upon following conditions:
1. That, in opinion of Architect / Engineer and Department, proposed material or equipment item is fully equal or superior (in design, materials, construction, workmanship, performance, finish, etc.) to named item. No compromise in quality level, however small, is acceptable.
  2. That, in substituting materials or equipment, Contractor assumes responsibility for any changes in system or for modifications required in adjacent or related work to accommodate such substitution despite Architect / Engineer's and Department's approval, and all costs growing out of approval of "or equal" items shall be responsibility of Contractor. No extra costs resulting from such approval shall become responsibility of Department, Architect / Engineer or any other separate Contractor.
  3. It shall be understood that use of materials or equipment other than those specified, or approved equal by Architect / Engineer and Department, shall constitute violation of Contract, and that Architect / Engineer and Department shall have right to require removal of such materials or equipment and their replacement with specified materials or equipment at Contractor's expense.
  4. Product and manufacturer named first in Specifications or on information shown on Drawings is basis of selection of manufactured items and equipment, particularly mechanical equipment. In using other than first named products or manufacturers, including those specified as additionally approved or acceptable, Contractor assumes responsibility for any changes in system and for modifications in any work required to accommodate them. Architect / Engineer's approval of such additionally acceptable products or manufacturers, either in Specifications or in Addendum, does not relieve Contractor from obligation to coordinate such optional products with other Contractors, whose work may be affected by them, and to pay all additional costs resulting from their inclusion into the Work. Contractor's liability shall include payment of Architect / Engineer's fees for any additional services made necessary by or directly connected to such product changes. No extra costs resulting from such changes shall become responsibility of Department, Architect / Engineer or any other separate Contractor.
- C. No request for approval of "or equal" materials will be entertained except from Contractor. Identify any request for substitution as substitution on Contractor's letter of transmittal and give reasons for substitution. Department may in its sole discretion allow substitutions of materials.

## **11. PATENTS AND ROYALTIES**

- A. If Contractor uses any design, device or material covered by letters, patent or copyright, it is mutually agreed and understood, that, without exception, contract prices shall include all royalties or costs arising from use of such design, device or materials, in any way involved in the Work.
- B. Contractor shall indemnify and save harmless County from any and all claims for infringement by reason of use of such patent or copyright in connection with the Work agreed to be performed under this Contract, and shall indemnify County for any cost, expense or damage which it may be obliged to pay by reason of such infringement at any time during prosecution of the Work or after completion of the Work.

## **12. SURVEYS, PERMITS, REGULATIONS AND TAXES**

- A. Department will furnish to Contractor all site, topography and property surveys necessary for execution of the Work.
- B. Contractor shall procure all permits, licenses and approvals necessary for execution of this Contract.
- C. Contractor shall give all notices and comply with all State of Wisconsin, Federal and local laws, codes, rules and regulations relating to performance of the Work, protection of adjacent property, and maintenance of passageways, guard fences or other protective facilities.
- D. Contractor shall pay all Sales, Consumer, Use and other similar taxes required by law.
- E. Contractor shall promptly notify Architect / Engineer of any variances of Drawings or Specifications with that of any State of Wisconsin, federal or local law, code, rule or regulation. Upon such notification, Architect / Engineer will require correction of variance to comply with applicable law, code, rule or regulation at no additional cost to Contractor.
- F. Work under this Contract shall comply with all applicable State of Wisconsin, Federal and local laws, codes and regulations.
- G. Contractor shall pay charges for water, sewer and other utility connections made by municipalities where required by Specifications.

## **13. CONTRACTOR'S OBLIGATIONS AND SUPERINTENDENCE**

- A. Contractor shall provide and pay for all materials, labor, tools, equipment, transportation and superintendence necessary to execute, complete and deliver the Work within specified time. Contractor agrees to secure at their own expense all personnel necessary to carry out the Work. Such personnel shall not be deemed County employees nor shall they have or be deemed to have any direct contractual relationship with County.
- B. Performance of any work necessary after regular working hours, on Sundays or Legal Holidays shall be without additional expense to County. Performance of any work at site at other than normal working hours must be coordinated with Public Works Project Manager.
- C. Contractor shall furnish, erect, maintain and remove such temporary works as may be required.
- D. Contractor shall observe, comply with, and be subject to all terms, conditions, requirements and limitations of Construction Documents.
- E. At the Work site, Contractor shall give personal superintendence to the Work or shall employ construction superintendent or foreman, experienced in character of work covered by Contract, who shall have full authority to act for Contractor. Understand that such superintendent or foreman shall be acceptable to Architect / Engineer and Department.
- F. Remove from project or take other corrective action upon notice from Architect / Engineer or Department for Contractor's employees whose work is considered by Architect / Engineer or Department to be unsatisfactory, careless, incompetent, unskilled or otherwise objectionable.

- G. Contractor and subcontractors shall be required to conform to Labor Laws of State of Wisconsin and various acts amendatory and supplementary thereto and to other laws, ordinances and legal requirements applicable to the Work.
- H. Presence and observation of the Work by Architect / Engineer or Public Works Project Manager shall not relieve Contractor of any obligations.

#### **14. WEATHER CONDITIONS**

- A. In event of temporary suspension of work, or during inclement weather, or whenever Architect / Engineer shall direct, Contractor shall, and shall cause subcontractors to protect carefully all work and materials against damage or injury from weather. If, in opinion of Architect / Engineer or Department, any work or materials that have been damaged or injured due to failure on part of Contractor or any subcontractors so to protect the Work, such materials shall be removed and replaced at expense of Contractor.

#### **15. PROTECTION OF WORK AND PROPERTY**

- A. Contractor shall at all times safely guard County's property from injury or loss in connection with this Contract. Contractor shall at all times safely guard and protect the Work, and adjacent property, from damage. Contractor shall replace or make good any such damage, loss or injury unless such is caused directly by errors contained in Contract, or by County, or County's duly authorized representative.
- B. Contractor may act diligently, without previous instructions from Architect / Engineer and / or Department, in emergency that threatens loss or injury of property, or safety of life. Contractor shall notify Architect / Engineer and / or Department immediately thereafter. Promptly submit any claim for compensation by Contractor due to such extra work to Architect / Engineer and / or Department for approval as provided for in Article 18 herein.

#### **16. INSPECTION AND TESTING OF MATERIALS**

- A. Authorized representatives and agents of County government shall have access at all times to the Work wherever it is in preparation or progress and Contractor shall provide facilities for such access and for inspection.
- B. Should it be considered necessary or advisable at any time before final acceptance of the Work to make examination of work already completed, by removing or tearing out same, Contractor shall upon request, promptly furnish all necessary facilities, labor and materials. If such work is found to be defective in any aspect, due to fault of Contractor or subcontractors thereof, Contractor shall assume all expenses of such examination and of satisfactory reconstruction. Contractor will be reimbursed for such examination and replacement in accordance with Article 18 - A.3., of these General Conditions of Contract if such work is found to meet requirements of Contract.
- C. If Specifications, Architect / Engineer's, or Public Works Project Manager's instructions require any work to be specially tested or approved, Contractor shall give Architect / Engineer and Public Works Project Manager timely notice of its readiness for testing or inspection. Test all materials and equipment requiring testing in accordance with accepted or specified standards, as applicable. Architect / Engineer shall recommend laboratory or inspection agency and Department will select and pay for all initial laboratory inspection

services. Should retesting be required, due to failure of initial testing, cost of such retesting shall be borne by Contractor.

- D. Cost of any testing performed by manufacturers or Contractor for substantiating acceptability of proposed substitution of materials and equipment, or necessary conformance testing in conjunction with manufacturing processes or factory assemblage, shall be borne by Contractor or manufacturer responsible.

## **17. REPORTS, RECORDS AND DATA**

- A. Contractor shall submit to Architect / Engineer and Public Works Project Manager such schedule of quantities and costs, progress schedules, payrolls, reports, estimates, invoices, records and other data as either may request concerning work performed or to be performed under this Contract.

## **18. CHANGES IN THE WORK**

- A. Make no changes, except in cases of emergency, in the Work covered by approved Construction Documents without having prior written approval of Department. Charges or credits for the Work covered by approved change shall be determined by one of these methods:
1. Unit bid prices previously approved.
  2. Agreed lump sum based on actual cost of:
    - a) Labor, including foremen, and all fringe benefits that are associated with their wages.
    - b) Materials entering permanently into the Work.
    - c) Ownership or rental cost of construction tools and equipment during time of use on extra work.
    - d) Power and consumable supplies for operation of power equipment.
    - e) Workmen's Compensation Insurance, Contractor's Public Liability and Property Damage Insurance, and Comprehensive Automobile Liability Insurance.
    - f) Social Security and old age and unemployment contributions.
    - g) Add to cost under (2), fixed fee to be agreed upon, but not to exceed fifteen percent (15%) of actual cost of work performed with their own labor force. Fee shall be compensation to cover cost of supervision, overhead, bond, profit and any other general expense.
    - h) On that portion of the Work under (2) done under subcontract, Contractor may include not over seven and one-half percent (7½%) for supervision, overhead, bond, profit and any other general expense.
    - i) Department may require correct amount of costs with supporting vouchers; Contractor shall keep and present in such form as directed.
  3. Cost-plus work, with not-to-exceed dollar limit, based on actual cost of:
    - a) Labor, including foremen, and all fringe benefits that are associated with their wages.
    - b) Materials entering permanently into the Work.
    - c) Ownership or rental cost of construction tools and equipment during time of use on extra work. Rental cost cannot exceed fifty percent (50%) replacement value of rented equipment.
    - d) Power and consumable supplies for operation of power equipment.
    - e) Workmen's Compensation Insurance, Contractor's Public Liability and Property Damage Insurance, and Comprehensive Automobile Liability Insurance.
    - f) Social Security and old age and unemployment contributions.
    - g) To cost under (3), there shall be added fixed fee to be agreed upon but not to exceed fifteen percent (15%) of actual cost of work performed with their own labor force.

Fee shall be compensation to cover cost of supervision, overhead, bond, profit, and any other general expense.

- h) On that portion of the Work under (3) done under subcontract, Contractor may include not over seven and one-half percent (7½%) for supervision, overhead, bond, profit, and any other general expense.
  - i) Contractor shall keep and present, in such form as directed, correct amount of cost together with such supporting vouchers as may be required by Department.
- B. If Contractor claims that by any instructions given by Architect / Engineer, Department, by drawings or otherwise, regarding performance of the Work or furnishing of material under Contract, involves extra cost, Contractor shall give Department written notice of cost thereof within two (2) weeks after receipt of such instructions and in any event before proceeding to execute work, unless delay in executing work would endanger life or property.
- C. No claim for extra work or cost shall be allowed unless it was done in pursuance of written Change Order from Architect / Engineer and approved by Department, as previously mentioned, and claim presented with payment request submitted after changed or extra work is completed.
- D. Negotiation of cost for change in the Work shall not be cause for Contractor to delay prosecution of the Work if Contractor has been authorized in writing by Public Works Project Manager to proceed.

## **19. EXTRAS**

- A. Without invalidating Contract, Department may order extra work or make changes by altering, adding to or deducting from the Work, contract sum being adjusted in accordance with Article 18 herein.

## **20. TIME FOR COMPLETION**

- A. Contractor agrees that the Work shall be prosecuted regularly and diligently and complete the Work as stated in Construction Documents.

## **21. CORRECTION OF WORK**

- A. All work, all materials whether incorporated in the Work or not, and all processes of manufacture shall at all times and places be subject to inspection of Architect / Engineer and Public Works Project Manager who shall be judge of quality and suitability of the Work, materials, and processes of manufacture for purposes for which they are used. Should they fail to meet Architect / Engineer's and Public Works Project Manager's approval they shall be reconstructed, made good, replaced or corrected, by Contractor at Contractor's expense. Immediately remove all rejected material from site.
- B. If Contractor defaults or neglects to carry out the Work in accordance with Construction Documents or fails to perform any provision of Contract, Department may, after ten (10) business days' written notice to Contractor and without prejudice to any other remedy County may have, make good such deficiencies. In such case, appropriate Change Order shall be issued deducting from Contractor's payments then or thereafter, cost of correcting such deficiencies, including cost of Architect / Engineer's additional services made necessary by such default, neglect or failure.

## **22. SUBSURFACE CONDITIONS FOUND DIFFERENT**

- A. If Contractor encounters subsurface or latent conditions at site materially differing from those shown on Drawings or indicated in Specifications, Contractor shall immediately give notice to Architect / Engineer and Public Works Project Manager of such conditions before they are disturbed. Architect / Engineer will thereupon promptly investigate conditions, and if Architect / Engineer finds that they materially differ from those shown on Drawings or indicated in Specifications, Architect / Engineer will at once make such changes as necessary, any increase or decrease of cost resulting from such changes to be adjusted in manner provided in above Article 18 entitled "Changes in the Work".

## **23. RIGHT OF DEPARTMENT TO TERMINATE CONTRACT**

- A. In event that any provisions of this Contract are violated by Contractor or by any subcontractors, County may serve written notice upon Contractor and Surety of its intention to terminate Contract, such notice to contain reasons for such intention to terminate Contract, and unless within ten (10) business days after serving of such notice upon Contractor, such violation or delay shall cease and satisfactory arrangement or correction be made, Contract shall, upon expiration of said ten (10) business days, cease and terminate.
- B. In event of any such termination, County shall immediately serve notice thereof upon Surety and Contractor, and Surety shall have right to take over and perform Contract subject to County's approval; provided, however, that if Surety does not commence performance thereof within ten (10) business days from date of mailing to such Surety of notice of termination, County may take over the Work and prosecute same to completion by contract, or by force account, at expense of Contractor; Contractor and Surety shall be liable to County for any excess cost occasioned County thereby, and in such event County may take possession of and utilize in completing the Work, such materials and equipment as may be on the Work site and therefore necessary.

## **24. CONSTRUCTION SCHEDULE AND PERIODIC ESTIMATES**

- A. Contractor shall be responsible for Construction Schedule and coordination. Immediately after execution and delivery of Contract and before making first payment, Contractor shall notify all subcontractors to furnish all required information to develop Construction Schedule. Contractor and all subcontractors associated with the Work shall furnish following information from each Division of Specifications:
1. List of construction activities;
  2. Start, finish and time required for completion of each activity;
  3. Sequential relationships between activities;
  4. Identify all long lead-time items, key events, meetings or activities such as required submittals, fabrication and delivery, procurement of materials, installation and testing;
  5. Weekly definition of extent of work and areas of activity for each trade or Subcontract; and
  6. Other information as determined by Public Works Project Manager.
- B. In addition to above requested items, Contractor shall request delivery dates for all County-furnished equipment, materials or labor. This shall include any work handled by Department under separate contracts such as asbestos abatement, air and water balancing, etc. Indicate on Construction Schedule these associated delivery and installation dates.
- C. Progress Reporting:



1. Contractor shall update and publish Construction Schedule on monthly basis. Revisions to Schedule shall be by Contractor and made in same detail as original Schedule and accompanied by explanation of reasons for revision; and shall be subject to approval by Department.
  2. Failure of Contractor to keep Schedule in updated format shall result in County hiring firm specializing in construction schedule development and deducting those costs associated with updating process from payments due Contractor.
  3. Contractor shall submit show actual percentage of each activity completed, estimated future progress, and anticipated completion time.
- D. Responsibility for timely completion requires:
1. Contractor and subcontractors understand that performance of each is interdependent upon performance of others.
  2. Whenever it becomes apparent from current schedule, that phasing or progress completion dates will not be met, Contractor must take some or all following actions at no additional cost to County:
    - a) Increase construction labor in such quantities and crafts as will eliminate backlog of work.
    - b) Increase number of working hours per shift, shifts per working day, working days per week, amount of construction equipment, or any combination of foregoing to eliminate backlog of work.
    - c) Reschedule work (yet remain in conformance with Drawings and Specifications).
  3. Prior to proceeding with any of above actions, Contractor shall notify Public Works Project Manager.
- E. Maintain current Construction Schedule at all times. Revise Construction Schedule in same detail as original and accompany with explanation of reasons for revision. Schedule shall be subject to approval by Architect / Engineer and Public Works Project Manager.

## **25. PAYMENTS TO CONTRACTOR**

- A. Contractor shall provide:
1. Detailed estimate giving complete breakdown of contract price by Specification Division; and
  2. Periodic itemized estimates of work done for purpose of making partial payments thereon.
- B. Submit these estimates for approval first to Architect / Engineer, then to Public Works Project Manager. Costs employed in making up any of these schedules are for determining basis of partial payments and not considered as fixing basis for additions to or deductions from Contract price.
- C. County will make partial payments to Contractor for value, proportionate to amount of Contract, of all labor and material incorporated in the Work during preceding calendar month upon receipt of Application and Certificate for Payment form from Architect / Engineer and approval of Department.
- D. Contractor shall submit for approval first to Architect / Engineer, and then to Public Works Project Manager all Application and Certificate for Payment forms. If requested, Application and Certificate for Payment shall be supported by such additional evidence as may be required, showing Contractor's right to payment claimed.

- E. Application and Certificate for Payment for preparatory work and materials delivered and suitably stored at site to be incorporated into the Work at some future period, will be given due consideration. Requesting payment for materials stored off site, may be rejected, however, if deemed essential for reasons of job progress, protection, or other sufficient cause, requests will be considered, conditional upon submission by Contractor of bills of sale, photographs and such other procedures as will adequately protect County's interest such as storage in bonded warehouse with adequate coverage. If there is any error in payment, Contractor is obligated to notify Department immediately, but no longer than ten (10) business days from receipt of payment.
- F. Payments by County will be due within forty-five (45) business days after receipt by Department of Application and Certificate for Payment.
- G. County will retain five percent (5%) of each Application and Certificate for Payment until final completion and acceptance of all the Work covered by Contract. However, anytime after fifty percent (50%) of the Work has been furnished and installed at site, County will make remaining payments in full if Architect / Engineer and Public Works Project Manager find that progress of the Work corresponds with Construction Schedule. If Architect / Engineer and Public Works Project Manager find that progress of the Work does not correspond with Construction Schedule, County may retain up to ten percent (10%) of each Application and Certificate for Payment for the Work completed.
- H. All material and work covered by partial payments made shall become sole property of County, but this provision shall not be construed as relieving Contractor from sole responsibility for care and protection of materials and work upon which payments have been made, or restoration of any damaged work, or as waiver of right of County to require fulfillment of all of terms of Contract.
- I. County will make final payment within sixty (60) calendar days after final completion of the Work, and will constitute acceptance thereof.
- J. County may make payment in full, including retained percentages and less authorized deductions, upon completion and acceptance of each Division where price is stated separately in Contract.
- K. Every contractor engaged in performance of any contract for Department of Public Works, Highway & Transportation shall submit to this Department, as requested and with final application for payment for work under said contract, affidavit(s) as required to prove that all debts and claims against this Work are paid in full or otherwise satisfied, and give final evidence of release of all liens against the Work and County. Use "Dane County, Wisconsin Contractor Wage Affidavit" form included in Supplementary Conditions.

## **26. WITHHOLDING OF PAYMENTS**

- A. County, after having served written notice on said Contractor, may either pay directly any unpaid bills of which Department has written notice, or withhold from Contractor's unpaid compensation sum of money deemed reasonably sufficient to pay any and all such lawful claims until satisfactory evidence is furnished that all liabilities have been fully discharged; whereupon, payment to Contractor shall be resumed in accordance with terms of this Contract, but in no event shall these provisions be construed to impose any obligations upon County to either Contractor or Contractor's Surety.

- B. In paying any unpaid bills of Contractor, County shall be deemed agent of Contractor, and any payment so made by County, shall be considered as payment made under Contract by County to Contractor and County shall not be liable to Contractor for any such payment made in good faith.
- C. Contractor shall indemnify, hold harmless and defend Dane County, its boards, commissions, agencies, officers, employees and representatives from all claims growing out of lawful demands of subcontractors, laborers, workers, mechanics, material men, and furnishers of machinery and parts thereof, equipment, power tools, and all supplies, including commissary, incurred in performance of this Contract.
- D. At Department's request, Contractor shall furnish satisfactory evidence that all obligations of nature designated above have been paid, discharged or waived.

## **27. ACCEPTANCE OF FINAL PAYMENT AS RELEASE**

- A. Making of final payment shall constitute waiver of all claims by County except those arising from:
  - 1. Unsettled lien;
  - 2. Faulty or defective work appearing after substantial completion;
  - 3. Failure of the Work to comply with requirements of Construction Documents; or
  - 4. Terms of any special guarantees required by Construction Documents.
- B. Acceptance of final payment shall constitute waiver of all claims by Contractor.

## **28. PAYMENTS BY CONTRACTOR**

- A. Contractor shall pay following not later than fifth (5<sup>th</sup>) business day following each payment received from County:
  - 1. All transportation and utility services rendered;
  - 2. All materials, tools, and other expendable equipment that have been delivered at site of the Work to extent of ninety percent (90%) of cost thereof, and balance of cost thereof when said balance is paid to Contractor; and
  - 3. Each subcontractor, respective amount allowed Contractor because of work performed by subcontractor to extent of subcontractor's interest therein.

## **29. CONTRACT SECURITY**

- A. Contractor shall furnish Performance and Payment Bonds in amount at least equal to one hundred percent (100%) of Contract price as security for faithful performance of this Contract and payment of all persons performing labor on project under this Contract and furnishing materials in connection with this Contract.
- B. Sample Performance and Payment Bonds that Contractor will be required to execute is bound into these Construction Documents. Before construction Contract is consummated, completed Performance and Payment Bonds must be approved by Department.

## **30. ASSIGNMENTS**

- A. Contractor shall not assign whole or any part of this Contract or any moneys due or to become due hereunder without written consent of Department. In case Contractor assigns all or any part of any moneys due or to become due under this Contract, instrument of

assignment shall contain clause substantially to effect that it is agreed that right of assignee in and to any moneys due or to become due to Contractor shall be subject to prior claims of all persons, firms and corporations for services rendered or materials supplied for performance of the Work called for in this Contract.

### **31. MUTUAL RESPONSIBILITY OF CONTRACTORS**

- A. If, through acts of neglect on part of Contractor or any subcontractor shall suffer loss or damage on the Work, Contractor agrees to settle with such subcontractor by agreement or arbitration if such other subcontractor will so settle. If such subcontractor shall assert any claim against County on account of any damage alleged to have been sustained, Department shall notify Contractor, who shall indemnify, hold harmless and defend Dane County, its boards, commissions, agencies, officers, employees and representatives against any such claim.

### **32. SEPARATE CONTRACTS**

- A. Department may award other contracts for the Work and all Contractors shall fully cooperate with each other and carefully adjust their work to that provided under other contracts as may be directed by Department. No Contractor shall commit or permit any act that will interfere with performance of the Work by any other Contractor.
- B. Contractor shall coordinate the Work with those of other Contractors. Cooperation will be required in arrangement for storage of materials and in detailed execution of the Work. Contractor, including subcontractors, shall keep informed of progress and detail work of others and shall notify Architect / Engineer or Department immediately of lack of progress or defective workmanship on part of others. Failure of Contractor to keep informed of the Work progressing on site and failure to give notice of lack of progress or defective workmanship by others shall be construed as acceptance by Contractor of status of the Work as being satisfactory for proper coordination with Contractor's own work.

### **33. SUBCONTRACTS**

- A. Contractor may use services of specialty subcontractors on those parts of the Work that, under normal contracting practices, are performed by specialty subcontractors.
- B. Contractor shall not award any work to any subcontractor without prior approval of Department. Qualifications of subcontractors shall be same as qualifications of Contractor. Request for subcontractor approval shall be submitted to Department fifteen (15) business days before start of subcontractor's work. If subcontractors are changed or added, Contractor shall notify Department in writing.
- C. Contractor shall be as fully responsible to County for acts and omissions of subcontractors, and of persons either directly or indirectly employed by them, as Contractor is for acts and omissions of persons directly employed by Contractor.
- D. Contractor shall cause appropriate provisions to be inserted in all subcontracts relative to the Work to bind subcontractors to Contractor by terms of General Conditions of Contract and other Construction Documents insofar as applicable to work of subcontractors and to give Contractor same power as regards terminating any subcontract that Department may exercise over Contractor under any provision of Construction Documents.

- E. Nothing contained in this Contract shall create any contractual relation between any subcontractor and County.
- F. Contractor shall insert in all subcontracts, Articles 26, 33, 43 and 45, respectively entitled: “Withholding of Payments”, “Subcontracts”, “Affirmative Action Provision and Minority / Women / Disadvantaged Business Enterprises”, and “Minimum Wages”, and shall further require all subcontractors to incorporate physically these same Articles in all subcontracts.

#### **34. PUBLIC WORKS PROJECT MANAGER’S AUTHORITY**

- A. Public Works Project Manager shall:
  - 1. Administer and ensure compliance with Construction Documents;
  - 2. Provide responsible on-site observations of construction and have authority to request work and to stop work whenever necessary to insure proper enforcement of Construction Documents;
  - 3. Convene and chair project meetings and foreman’s coordination meetings when necessary to coordinate resolution of conflicts between Contractors, Architects, Engineers, Consultants, and Department; and
  - 4. Check and inspect material, equipment and installation procedures of all trades for proper workmanship and for compliance with Drawings, Specifications and Shop Drawings, permit no material on project site that is not satisfactory and reject work not in compliance with Construction Documents.

#### **35. ARCHITECT / ENGINEER’S AUTHORITY**

- A. Architect / Engineer is retained by, and is responsible to Department acting for County.
- B. Architect / Engineer shall determine amount, quality, acceptability, and fitness of several kinds of work and materials that are provided under this Contract and shall decide all questions that may arise in relation to said work and construction thereof.
- C. Architect / Engineer shall decide meaning and intent of any portion of Specifications and of any Drawings where they may be found obscure or be in dispute.
- D. Architect / Engineer shall provide responsible observation of construction. Architect / Engineer has authority to stop the Work whenever such stoppage may be necessary to insure proper execution of Construction Documents.
- E. Architect / Engineer shall be interpreter of conditions of Construction Documents and judge of its performance.
- F. Within reasonable time, Architect / Engineer shall make decisions on all matters relating to progress of the Work or interpretation of Construction Documents.
- G. Architect / Engineer’s decisions are subject to review by Public Works Project Manager.

#### **36. STATED ALLOWANCES**

- A. Stated allowances enumerated in Instructions to Bidders shall cover net cost of materials or equipment, and all applicable taxes. Contractor’s cost of delivery and unloading at site, handling costs on site, labor, installation costs, overhead, profit and any other incidental costs shall be included in Contractor’s bid, but not as part of cash allowance.

- B. Department will solicit at least two (2) bids on materials or equipment for which allowance is stated and select on basis of lowest qualified responsible bid. Contractor will then be instructed to purchase "Allowed Materials". If actual price for purchasing "Allowed Materials", including taxes, is more or less than "Cash Allowance", Contract price shall be adjusted accordingly. Adjustment in Contract price shall not contain any cost items excluded from cash allowance.

### **37. ESTIMATES OF QUANTITIES**

- A. Whenever estimated quantities of work to be done and materials to be furnished under this Contract are shown in any of Construction Documents, they are given for use in comparing bids and right is especially reserved to increase or diminish them as they may be deemed reasonably necessary or desirable by Department to complete the Work included in this Contract, and cost for such increase or diminution shall be adjusted in manner provided for in General Conditions of Contract Article 18 entitled "Changes in the Work".

### **38. LANDS AND RIGHTS-OF-WAY**

- A. Prior to start of construction, County shall furnish all land and rights-of-way necessary for carrying out and completion of the Work to be performed under this Contract.

### **39. GENERAL GUARANTEE**

- A. Neither final certificate of payment nor any provision in Construction Documents nor partial or entire occupancy of premises by County shall constitute acceptance of work not done in accordance with Construction Documents or relieve Contractor of liability in respect to any expressed warranties or responsibility for faulty materials or workmanship.
  - 1. In no event shall making of any payment required by Contract constitute or be construed as waiver by County of any breach of covenants of Contract or waiver of any default of Contractor and making of any such payment by County while any such default or breach shall exist shall in no way impair or prejudice right of County with respect to recovery of damages or other remedy as result of such breach or default.
- B. Contractor shall remedy and make good all defective workmanship and materials and pay for any damage to other work resulting there from, which appear within period of one (1) year from date of substantial completion, providing such defects are not clearly due to abuse or misuse by County. Department will give notice of observed defects with reasonable promptness.
- C. Guarantee on work executed after certified date of substantial completion will begin on date when such work is inspected and approved by Architect / Engineer and Public Works Project Manager.
- D. Where guarantees or warranties are required in sections of Specifications for periods in excess of one (1) year, such longer terms shall apply; however, Contractor's Performance and Payment Bonds shall not apply to any guarantee or warranty period in excess of one (1) year.

### **40. CONFLICTING CONDITIONS**

- A. Any provision in any of Construction Documents which may be in conflict or inconsistent with any Articles in these General Conditions of Contract or Supplementary Conditions shall be void to extent of such conflict or inconsistency.
- B. In case of ambiguity or conflict between Drawings and Specifications, Specifications shall govern.
- C. Printed dimensions shall be followed in preference to measurements by scale. Large-scale drawings take precedence over small-scale drawings. Dimensions on Drawings and details are subject to field measurements of adjacent work.

### **41. NOTICE AND SERVICE THEREOF**

- A. Any notice to Contractor from Department relative to any part of this Contract shall be in writing and considered delivered and service thereof completed, when said notice is posted, by certified or registered mail, to Contractor at Contractor's last given address, or delivered in person to said Contractor, or Contractor's authorized representative on the Work.

## **42. PROTECTION OF LIVES AND HEALTH**

- A. In order to protect lives and health of Contractor's employees under Contract, Contractor shall comply with all pertinent provisions of Wisconsin Administrative Code, Rules of Department of Commerce, relating to Safety and Health.
- B. Contractor alone shall be responsible for safety, efficiency and adequacy of Contractor's tools, equipment and methods, and for any damage that may result from their failure or their improper construction, maintenance or operation.

## **43. AFFIRMATIVE ACTION PROVISION AND MINORITY / WOMEN / DISADVANTAGED BUSINESS ENTERPRISES**

- A. Affirmative Action Provisions.
  - 1. During term of their Contract, Contractor agrees not to discriminate on basis of race, religion, color, sex, handicap, age, sexual preference, marital status, physical appearance, or national origin against any person, whether recipient of services (actual or potential), employee, or applicant for employment. Such equal opportunity shall include but not be limited to following: employment, upgrading, demotion, transfer, recruitment, advertising, layoff, termination, training, rates of pay, and any other form of compensation or level of service(s). Contractor agrees to post in conspicuous places, these affirmative action standards so as to be visible to all employees, service recipients and applicants for this paragraph. Listing of prohibited bases for discrimination shall not be construed to amend in any fashion state or federal law setting forth additional bases and exceptions shall be permitted only to extent allowable in state or federal law.
  - 2. Contractor is subject to this Article only if Contractor has ten (10) or more employees and receives \$10,000.00 or more in annual aggregate contracts with County. Contractor shall file and Affirmative Action Plan with Dane County Contract Compliance Officer in accord with Chapter 19 of Dane County Code of Ordinances. Such plan must be filed within fifteen (15) business days of effective date of this Contract and failure to do so by said date shall constitute ground for immediate termination of Contract by County. Contractor shall also, during term of this Contract, provide copies of all announcements of employment opportunities to County's Contract Compliance Office, and shall report annually number of persons, by race, sex and handicap status, who apply for employment, and, similarly classified, number hired and number rejected.
  - 3. Contact Dane County Contract Compliance Officer at Dane County Contract Compliance Office, 210 Martin Luther King, Jr. Blvd., Room 421, Madison, WI 53703, 608/266-4114.
  - 4. In all solicitations for employment placed on Contractor's behalf during term of this Contract, Contractor shall include statement to affect Contractor is "Equal Opportunity Employer". Contractor agrees to furnish all information and reports required by County's Contract Compliance Officer as same relate to affirmative action and nondiscrimination, which may include any books, records, or accounts deemed appropriate to determine compliance with Chapter 19, Dane County Code of Ordinances, and provision of this Contract.
- B. Minority / Women / Disadvantaged / Emerging Small Business Enterprises.
  - 1. Chapter 19.508 of Dane County Code of Ordinances is official policy of Dane County regarding utilization of, to fullest extent of, Minority Business Enterprises (MBEs), Women Business Enterprises (WBEs) Disadvantage Business Enterprises (DBEs) and Emerging Small Business Enterprises (ESBEs).
  - 2. Contractor may utilize MBEs / WBEs / DBEs / ESBEs as subcontractors or suppliers. List of subcontractors will be required of low bidder as stated in this Contract. List shall



indicate which are MBEs / WBEs / DBEs / ESBEs and percentage of subcontract awarded, shown as percentage of total dollar amount of bid.

#### **44. COMPLIANCE WITH FAIR LABOR STANDARDS**

- A. During term of this Contract, Contractor shall report to County Contract Compliance Officer, within ten (10) business days, any allegations to, or findings by National Labor Relations Board (NLRB) or Wisconsin Employment Relations Commission (WERC) that Contractor has violated statute or regulation regarding labor standards or relations. If investigation by Contract Compliance Officer results in final determination that matter adversely affects Contractor's responsibilities under this Contract, and which recommends termination, suspension or cancellation of this Contract, County may take such action.
- B. Contractor may appeal any adverse finding by Contract Compliance Officer as set forth in Dane County Ordinance 25.015(11)(c) through (e).
- C. Contractor shall post this statement in prominent place visible to employees: "As condition of receiving and maintaining contract with Dane County, this employer shall comply with federal, state and all other applicable laws prohibiting retaliation or union organizing."

#### **45. DOMESTIC PARTNERSHIP BENEFITS**

- A. Not Used.

#### **46. USE AND OCCUPANCY PRIOR TO ACCEPTANCE**

- A. Contractor agrees to use and occupancy of portion or unit of the Work before formal acceptance by Department, provided Department:
  - 1. Secures written consent of Contractor; except when in opinion of Public Works Project Manager, Contractor is chargeable with unwarranted delay in final cleanup of punch list items or other Contract requirements.
  - 2. Secures endorsement from insurance carrier and consent of Surety permitting occupancy of building or use of the Work during remaining period of construction, or, secures consent of Surety.
  - 3. Assumes all costs and maintenance of heat, electricity and water.
  - 4. Accepts all work completed within that portion or unit of the Work to be occupied, at time of occupancy.

#### **47. MINIMUM WAGES**

- A. Not Used.

#### **48. CLAIMS**

- A. No claim may be made until Department's Assistant Public Works Director has reviewed Architect / Engineer's decision as provided for in Article 35 of General Conditions of Contract. If any claim remains unresolved after such review by Department's Assistant Public Works Director the claim may be filed under Wisconsin Statute 893.80. Work shall progress during period of any dispute or claim. Unless specifically agreed between parties, venue will be in Dane County, Wisconsin.

## **49. ANTITRUST AGREEMENT**

- A. Contractor and County recognize that in actual economic practice, overcharges resulting from antitrust violations are in fact usually borne by County. Therefore, Contractor hereby assigns to County any and all claims for such overcharges as to goods and materials purchased in connection with this Contract, except as to overcharges which result from antitrust violations commencing after price is established under this Contract and any change order thereto.

## **50. INSURANCE**

- A. Contractor Carried Insurance:
1. Contractor shall not commence work under this Contract until Contractor has obtained all insurance required under this Article and has provided evidence of such insurance to Risk Manager, 425 City-County Building, 210 Martin Luther King Jr. Blvd., Madison, WI 53703. Contractor shall not allow any subcontractor to commence work until insurance required of subcontractor has been so obtained and approved. Company providing insurance must be licensed to do business in Wisconsin.
  2. Worker's Compensation Insurance:
    - a) Contractor shall procure and shall maintain during life of this Contract, Worker's Compensation Insurance as required by statute for all of Contractor's employees engaged in work at site of project under this Contract and, in case of any such work sublet, Contractor shall require subcontractor similarly to provide Worker's Compensation Insurance for all of latter's employees to be engaged in such work unless such employees are covered by protection afforded by Contractor's Worker's Compensation Insurance.
    - b) If any claim of employees engaged in hazardous work on project under this Contract is not protected under Worker's Compensation Statute, Contractor shall provide and shall cause each subcontractor to provide adequate Employer's Liability Insurance for protection of such of Contractor's employees as are not otherwise protected.
  3. Contractor's Public Liability and Property Damage Insurance:
    - a) Contractor shall procure and maintain during life of this Contract, Contractor's Public Liability Insurance and Contractor's Property Damage Insurance in amount not less than \$1,000,000 bodily injury, including accidental death, to any one person, and subject to same limit for each person, in amount not less than \$1,000,000 on account of one accident, and Contractor's Property Damage Insurance in amount not less than \$1,000,000 or combined single limit of at least \$1,000,000 with excess coverage over and above general liability in amount not less than \$5,000,000. Contractor shall add "Dane County" as additional insured for each project.
    - b) Contractor's Public Liability and Property Damage Insurance shall include Products, Completed Operation, and Contractual Liability under Insurance Contract. "Contractor shall in all instances save, defend, indemnify and hold harmless County and Architect / Engineer against all claims, demands, liabilities, damages or any other costs which may accrue in prosecution of the Work and that Contractor will save, defend, indemnify and hold harmless County and Architect / Engineer from all damages caused by or as result of Contractor's operations" and each shall be listed as additional insured on Contractor's and sub-contractors' insurance policies.
    - c) Obligations of Contractor under Article 50.A.2.b) shall not extend to liability of Architect / Engineer, agents or employees thereof, arising out of:
      - 1) Preparation or approval of maps, drawings, opinions, reports, surveys, change orders, designs or specifications; or
      - 2) Giving of or failure to give directions or instructions by Architect / Engineer, agents or employees thereof provided such giving or failure to give is primary cause of injury or damage.

- d) Contractor shall procure and shall maintain during life of this Contract, Comprehensive Automobile Liability Insurance covering owned, non-owned and hired automobiles for limits of not less than \$1,000,000 each accident single limit, bodily injury and property damage combined with excess coverage over and above general liability in amount not less than \$5,000,000.
- e) Contractor shall either:
  - 1) Require each subcontractor to procure and to maintain during life of subcontract, subcontractor's Public Liability Property Damage Insurance, and Comprehensive Automobile Liability Insurance of type and in same amount specified in preceding paragraphs; or
  - 2) Insure activities of subcontractors in Contractor's own policy.
- 4. Scope of Insurance and Special Hazards: Insurance required under Article 50.A.2 & 50.A.3. hereof shall provide adequate protection for Contractor and subcontractors, respectively, against damage claims which may arise from operations under this Contract, whether such operation be by insured or by anyone directly or indirectly employed by insured and also against any of special hazards which may be encountered in performance of this Contract as enumerated in Supplementary Conditions.
- 5. Proof of Carriage of Insurance: Contractor shall furnish Risk Manager with certificates showing type, amount, class of operations covered, effective dates, dates of expiration of policies and "Dane County" listed as additional insured. Such certificates shall also contain (substantially) following statement: "Insurance covered by this certificate will not be canceled or materially altered, except after ten (10) business days written notice has been received by Risk Manager."

**B. Builder's Risk:**

- 1. County shall provide Builder's Risk insurance coverage for its insurable interests in construction or renovation projects with completed value of \$1,000,000 or less. Therefore, if project completed value is more than \$1,000,000, Contractor shall obtain and maintain in force, at its own expense, Builder's Risk Insurance on all risks for amount equal to full completed value of covered structure or replacement value of alterations or additions. Any deductible shall not exceed \$25,000 for each loss. Policy shall include occupancy clause and list Dane County as loss payee.

**C. Indemnification / Hold Harmless:**

- 1. Contractor shall indemnify, hold harmless and defend Dane County, its boards, commissions, agencies, officers, employees and representatives from and against all claims, damages, losses and expenses including attorneys' fees arising out of or resulting from performance of the Work, provided that any such claim, damage, loss or expense is attributable to bodily injury, sickness, disease or death, or to injury to or destruction of tangible property (other than the Work itself) including loss of use resulting therefrom, and is caused in whole or in part by any act or omission of Contractor, any subcontractor, anyone directly or indirectly employed by any of them or anyone for whose acts any of them may be liable, regardless of whether or not it is caused in part by part indemnified hereunder.
- 2. In any and all claims against Dane County, its boards, commissions, agencies, officers, employees and representatives or by any employee of Contractor, any subcontractor, anyone directly or indirectly employed by any of them or anyone for whose acts any of them may be liable, indemnification obligation under this Contract shall not be limited in any way by any limitation on amount or type of damages, compensation or benefits payable by or for Contractor or any subcontractor under worker's compensation acts, disability benefits or other employee benefit acts.
- 3. Obligations of Contractor under this Contract shall not extend to liability of Architect / Engineer, its agents or employees arising out of:

- a) Preparation or approval of maps, drawings, opinion, reports, surveys, change orders, designs or specifications; or
  - b) Giving of or failure to give directions or instruction by Architect / Engineer, its agents or employees provided such giving or failure to give is primary cause of injury or damage.
4. Dane County shall not be liable to Contractor for damages or delays resulting from work by third parties or by injunctions or other restraining orders obtained by third parties.

#### **51. WISCONSIN LAW CONTROLLING**

- A. It is expressly understood and agreed to by parties hereto that in event of any disagreement or controversy between parties, Wisconsin law shall be controlling.

# SUPPLEMENTARY CONDITIONS

## 1. APPLICATION & CERTIFICATE FOR PAYMENT

- A. Every contractor engaged in performance of any contract for Department of Public Works, Highway & Transportation shall submit partial and final Application & Certificate for Payment for work under said contract. Form shall provide similar information as shown on AIA G702™ and G703™ forms (samples shown below). Forms shall be submitted to Public Works Project Manager for approval.

**AIA** Document G702™ – 1992

**Application and Certificate for Payment**

TO OWNER:	PROJECT:	APPLICATION NO:	Distribution to:
FROM CONTRACTOR:	VIA ARCHITECT:	PERIOD TO:	OWNER <input type="checkbox"/>
		CONTRACT FOR:	ARCHITECT <input type="checkbox"/>
		CONTRACT DATE:	CONTRACTOR <input type="checkbox"/>
		PROJECT NOS:	FIELD <input type="checkbox"/>
			OTHER <input type="checkbox"/>

---

**CONTRACTOR'S APPLICATION FOR PAYMENT**

Application is made for payment, as shown below, in connection with the Contract. AIA Document G703™, Continuation Sheet, is attached.

1. ORIGINAL CONTRACT SUM ..... \$ \_\_\_\_\_

2. NET CHANGE BY CHANGE ORDERS ..... \$ \_\_\_\_\_

3. CONTRACT SUM TO DATE (Line 1 + 2) ..... \$ \_\_\_\_\_

4. TOTAL COMPLETED & STORED TO DATE (Column G on G703) ..... \$ \_\_\_\_\_

5. RETAINAGE:

a. \_\_\_\_\_ % of Completed Work  
(Columns D + E on G703) ..... \$ \_\_\_\_\_

b. \_\_\_\_\_ % of Stored Material  
(Column F on G703) ..... \$ \_\_\_\_\_

Total Retainage (Lines 5a + 5b, or Total in Column I of G703) ..... \$ \_\_\_\_\_

6. TOTAL EARNED LESS RETAINAGE ..... \$ \_\_\_\_\_  
(Line 4 minus Line 5 Total)

7. LESS PREVIOUS CERTIFICATES FOR PAYMENT ..... \$ \_\_\_\_\_  
(Line 6 from prior Certificate)

8. CURRENT PAYMENT DUE ..... \$ \_\_\_\_\_

9. BALANCE TO FINISH, INCLUDING RETAINAGE ..... \$ \_\_\_\_\_  
(Line 3 minus Line 6)

The undersigned Contractor certifies that to the best of the Contractor's knowledge, information and belief the Work covered by this Application for Payment has been completed in accordance with the Contract Documents, that all amounts have been paid by the Contractor for Work for which previous Certificates for Payment were issued and payments received from the Owner, and that current payment shown herein is now due.

CONTRACTOR:  
By: \_\_\_\_\_ Date: \_\_\_\_\_  
State of: \_\_\_\_\_  
County of: \_\_\_\_\_  
Subscribed and sworn to before me this \_\_\_\_\_ day of \_\_\_\_\_

Notary Public:  
My commission expires: \_\_\_\_\_

---

CHANGE ORDER SUMMARY	ADDITIONS	DEDUCTIONS
Total changes approved in previous months by Owner	\$ _____	\$ _____
Total approved this month	\$ _____	\$ _____
<b>TOTAL</b>	<b>\$ _____</b>	<b>\$ _____</b>
NET CHANGES by Change Order	\$ _____	

**ARCHITECT'S CERTIFICATE FOR PAYMENT**

In accordance with the Contract Documents, based on on-site observations and the data comprising this application, the Architect certifies to the Owner that to the best of the Architect's knowledge, information and belief the Work has progressed as indicated, the quality of the Work is in accordance with the Contract Documents, and the Contractor is entitled to payment of the AMOUNT CERTIFIED.

AMOUNT CERTIFIED ..... \$ \_\_\_\_\_  
(Attach explanation if amount certified differs from the amount applied. Initial all figures on this Application and on the Continuation Sheet that are changed to conform with the amount certified.)

ARCHITECT:  
By: \_\_\_\_\_ Date: \_\_\_\_\_

This Certificate is not negotiable. The AMOUNT CERTIFIED is payable only to the Contractor named herein. Issuance, payment and acceptance of payment are without prejudice to any rights of the Owner or Contractor under this Contract.

**CAUTION:** You should sign an original AIA Contract Document, on which this text appears in RED. An original assures that changes will not be obscured.

AIA Document G702™ – 1992, Copyright © 1963, 1963, 1965, 1971, 1978, 1983 and 1992 by The American Institute of Architects. All rights reserved. WARNING: This AIA® Document is protected by U.S. Copyright Law and International Treaties. Unauthorized reproduction or distribution of this AIA® Document, or any portion of it, may result in severe civil and criminal penalties, and will be prosecuted to the maximum extent possible under the law. Purchasers are permitted to reproduce ten (10) copies of this document when completed. To report copyright violations of AIA Contract Documents, e-mail The American Institute of Architects' legal counsel, copyright@aia.org. 010711A0204

**Continuation Sheet**

AIA Document G702™-1992, Application and Certificate for Payment, or G732™-2009, Application and Certificate for Payment, Construction Manager as Adviser Edition, containing Contractor's signed certification is attached. In tabulations below, amounts are in US dollars. Use Column I on Contracts where variable retainage for line items may apply.

APPLICATION NO:  
APPLICATION DATE:  
PERIOD TO:  
ARCHITECT'S PROJECT NO:

A ITEM NO.	B DESCRIPTION OF WORK	C SCHEDULED VALUE	D WORK COMPLETED		F MATERIALS PRESENTLY STORED <i>(Not in D or E)</i>	G TOTAL COMPLETED AND STORED TO DATE <i>(D+E-F)</i>	H BALANCE TO FINISH <i>(C-G)</i>	I RETAINAGE <i>(if variable rate)</i>
			FROM PREVIOUS APPLICATION <i>(D-E)</i>	THIS PERIOD				
GRAND TOTAL								

**CAUTION:** You should sign an original AIA Contract Document, on which this text appears in RED. An original assures that changes will not be obscured.

AIA Document G703™ – 1992. Copyright © 1963, 1965, 1966, 1967, 1970, 1978, 1983 and 1992 by The American Institute of Architects. All rights reserved. **WARNING:** This AIA® Document is protected by U.S. Copyright Law and International Treaties. Unauthorized reproduction or distribution of this AIA® Document, or any portion of it, may result in severe civil and criminal penalties, and will be prosecuted to the maximum extent possible under the law. Purchasers are permitted to reproduce ten (10) copies of this document when completed. To report copyright violations of AIA Contract Documents, e-mail The American Institute of Architects' legal counsel, [copyright@aia.org](mailto:copyright@aia.org). 10-1204504

NOT FOR  
SUBMITTAL

SECTION 01 00 00  
BASIC REQUIREMENTS

PART 1 GENERAL

1.1 SECTION SUMMARY

- A. Section Includes:
1. Section Summary
  2. Summary of the Work
  3. Contractor Use of Premises
  4. Applications for Payment
  5. Change Procedures
  6. Alternates
  7. Lump Sum Allowances for Work
  8. Coordination
  9. Cutting and Patching
  10. Conferences
  11. Progress Meetings
  12. Job Site Administration
  13. Submittal Procedures
  14. Proposed Products List
  15. Shop Drawings
  16. Product Data
  17. Samples
  18. Manufacturers' Instructions
  19. Manufacturers' Certificates
  20. Quality Assurance / Quality Control of Installation
  21. References
  22. Interior Enclosures
  23. Protection of Installed Work
  24. Parking
  25. Staging Areas
  26. Occupancy During Construction and Conduct of Work
  27. Protection
  28. Progress Cleaning
  29. Products
  30. Transportation, Handling, Storage and Protection
  31. Product Options
  32. Substitutions
  33. Starting Systems
  34. Demonstration and Instructions
  35. Contract Closeout Procedures
  36. Final Cleaning
  37. Adjusting
  38. Operation and Maintenance Data
  39. Spare Parts and Maintenance Materials

40. As-Built and Record Drawings and Specifications

1.2 SUMMARY OF THE WORK

- A. Project Description: Perform the Work as specified and detailed in Construction Documents package. Contractor to provide ....
- B. Work by Owner: Not applicable.
- C. Permits: Not applicable.
- D. Permits: Prior to commencement of the Work, Contractor to secure any and all necessary permits for completion of the Work and facility occupancy.
- E. Diggers Hotline:
  - 1. It is General Contractor's responsibility to contact Diggers Hotline to have all utility locations marked prior to excavation and planning excavation so as not to delay the Work.
  - 2. Diggers Hotline shall also be used to obtain information on safe working clearances from overhead lines.
  - 3. Completely comply with all requirements of each affected utility company.
  - 4. It is General Contractor's responsibility to contact & hire private utility locating services if necessary.

1.3 CONTRACTOR USE OF PREMISES

- A. Limit use of premises to allow work by others and work by Owner.
- B. Limit use of premises to allow work by Contractors or Subcontractors and access by Owner.
- C. Coordinate utility outages and shutdowns with Owner.

1.4 APPLICATIONS FOR PAYMENT

- A. Submit one (1) original copies with "wet" signatures of each application on AIA G702™ and G703™ forms or approved contractors invoice form.
- B. Content and Format: Utilize Schedule of Values for listing items in Application for Payment.
- C. Payment Period: Monthly.
- D. Submit Applications for Payment to Public Works Project Manager for approval & processing for payment.



## 1.5 CHANGE PROCEDURES

- A. Change Order Forms: Dane County Contract Change Order, Form 014-32-20 (latest issue).
- B. Contractor's costs for Products, delivery, installation, labor, insurance, payroll, taxes, bonding, equipment rental, overhead and profit will be included in Change Orders authorizing expenditure of funds from contingency allowance.

## 1.6 ALTERNATES

- A. Alternates quoted on Bid Form shall be reviewed and accepted or rejected at Owner's option.
- B. Coordinate related work and modify surrounding work as required.
- C. Schedule of Alternates: there are no alternates proposed for this project.

## 1.7 LUMP SUM ALLOWANCES FOR WORK

- A. Not Applicable.

## 1.8 COORDINATION

- A. Coordinate scheduling, submittals, and work of various sections of Specifications to assure efficient and orderly sequence of installation of interdependent construction elements.
- B. Verify utility requirement characteristics of operating equipment are compatible with building utilities.
- C. Coordinate space requirements and installation of mechanical and electrical work that are indicated diagrammatically on Drawings.
- D. Refer to Drawings for recommended work sequence and duration.
- E. Contractor shall provide Public Works Project Engineer with work plan that ensures the Work will be completed within required time of completion.
- F. Public Works Project Manager may choose to photograph or videotape site or workers as the Work progresses.

## 1.9 CUTTING AND PATCHING

- A. Employ skilled and experienced installer to perform cutting and patching new work; restore work with new Products.
- B. Submit written request in advance of cutting or altering structural or building enclosure elements.

- C. Fit work tight to adjacent elements. Maintain integrity of wall, ceiling, or floor construction; completely seal voids.
- D. Refinish surfaces to match adjacent finishes.

#### 1.10 CONFERENCES

- A. Project shall have pre-bid conference; see Instructions to Bidders.
- B. Owner will schedule preconstruction conference after Award of Contract for all affected parties.
- C. Contractor shall submit Construction Schedule at pre-construction meeting.
- D. When required in individual Specification section, convene pre-installation conference at project site prior to commencing work of Section.

#### 1.11 PROGRESS MEETINGS

- A. Schedule and administer meetings throughout progress of the Work at minimum of one (1) per week with Public Works Project Manager.
- B. Preside at meetings, record minutes, and distribute copies within two (2) business days to those affected by decisions made.
- C. Attendance at progress meetings by General Contractor, subcontractors, or their authorized representative, is mandatory.
- D. Contractors shall give verbal reports of progress on the Work, discuss schedule for upcoming period and present all conflicts, discrepancies or other difficulties for resolution.
- E. Day & time of progress meetings to be determined at pre-construction meeting.

#### 1.12 JOB SITE ADMINISTRATION

- A. Contractor shall have project superintendent on site minimum of four (4) hours per week during progress of the Work.
- B. Architect / Engineer shall have representative on site regularly during progress of the Work.

#### 1.13 SUBMITTAL PROCEDURES

- A. Submittal form to identify Project, Contractor, Subcontractor or supplier; and pertinent Construction Documents references.
- B. Apply Contractor's stamp, signed or initialed, certifying that review, verification of Products required, field dimensions, adjacent construction work, and coordination of

information is in accordance with requirements of the Work and Construction Documents.

- C. Identify variations from Construction Documents and Product or system limitations that may be detrimental to successful performance of completing the Work.
- D. Revise and resubmit submittals as required; identify all changes made since previous submittal.

#### 1.14 PROPOSED PRODUCTS LIST

- A. Within fifteen (15) business days after date of Award of Contract, submit complete list of major Products proposed for use, with name of manufacturer, trade name, and model number of each Product.

#### 1.15 SHOP DRAWINGS

- A. Submit number of copies that Contractor requires, plus three (3) copies that shall be retained by Public Works Project Manager.

#### 1.16 PRODUCT DATA

- A. Submit number of copies that Contractor requires, plus two (2) copies that shall be retained by Public Works Project Manager.
- B. Mark each copy to identify applicable products, models, options, and other data. Supplement manufacturer's standard data to provide information unique to this Project.

#### 1.17 SAMPLES

- A. Submit samples to illustrate functional and aesthetic characteristics of Product.
- B. Submit samples of finishes from full range of manufacturers' standard colors, textures, and patterns for Public Works Project Manager's selection.

#### 1.18 MANUFACTURERS' INSTRUCTIONS

- A. When specified in individual Specification sections, submit manufacturers' printed instructions for delivery, storage, assembly, installation, start-up, adjusting, and finishing, in quantities specified for Product Data.

#### 1.19 MANUFACTURERS' CERTIFICATES

- A. When specified in individual Specification sections, submit manufacturers' certificate to Public Works Project Manager for review, in quantities specified for Product Data.
- B. Indicate material or Product conforms to or exceeds specified requirements. Submit supporting reference data, affidavits, and certifications as appropriate.

1.20 QUALITY ASSURANCE / QUALITY CONTROL OF INSTALLATION

- A. Monitor quality control over suppliers, manufacturers, Products, services, site conditions, and workmanship, to produce work of specified quality.
- B. Comply fully with manufacturers' instructions.
- C. Comply with specified standards as minimum quality for the Work except when more stringent tolerances, codes, or specified requirements indicate higher standards or more precise workmanship.

1.21 REFERENCES

- A. Conform to reference standard by date of issue current as of date for receiving bids.
- B. Should specified reference standard conflict with Construction Documents, request clarification from Public Works Project Manager before proceeding.

1.22 INTERIOR ENCLOSURES

- A. Provide temporary partitions as required to separate work areas from Owner occupied areas, to prevent distribution of dust and moisture into Owner occupied areas, and to prevent damage to existing materials and equipment.

1.23 PROTECTION OF INSTALLED WORK

- A. Protect installed work and provide special protection where specified in individual Specification sections.

1.24 PARKING

- A. Arrange for temporary parking areas to accommodate construction personnel. Parking shall be available at the Work site.
- B. All contractors and their employees shall cooperate with General Contractor and others in parking of vehicles to avoid interference with normal operations and construction activities.
- C. Do not obstruct existing service drives and parking lots with equipment, materials and / or vehicles. Keep accessible for Owner's use at all times.

1.25 STAGING AREAS

- A. Coordinate staging areas with Public Works Project Manager prior to starting the Work.
- B. On-site space for use as staging areas and storage of materials is limited and will be apportioned among various Contractors as their needs dictate with due regard for storage requirements of each Contractor. Each Contractor shall be responsible for safety of equipment and materials that are stored on site.

## 1.26 OCCUPANCY DURING CONSTRUCTION AND CONDUCT OF WORK

- A. All construction material and salvage material shall be removed from facility or secured at day's end.
- B. Smoking is prohibited on Dane County property.
- C. Owner reserves right at any time to dismiss from premises any Contractor or construction personnel that do not uphold requirements of this Section.
- D. Owner shall not be held liable for any lost time, wages, or impacts to construction schedule by any Contractor or construction personnel dismissed for failure to uphold requirements of this Section.
- E. Areas of existing facility will be occupied during period when the Work is in progress. Work may be done during normal business hours (8:00 am to 4:30 pm), but confer with Owner, schedule work and store materials so as to interfere as little as possible with normal use of premises. Work performed on Saturday shall be by permission of Owner. Notify Owner when coring or similar noise making work is to be done and obtain Owner's written approval of schedule. If schedule is not convenient for Owner, reschedule and resubmit new times for Owner approval. Coring of floor along with other noisy work may have to be done on second and third shifts.
- F. Work shall be done and temporary facilities furnished so as not to interfere with access to any occupied area and so as to cause least possible interference with normal operation of facility or any essential service thereof.
- G. Contractor shall, at all times, provide approved, safe walkways and facility entrances for use by Owner, employees and public.
- H. Contractor shall provide adequate protection for all parts of facility, its contents and occupants wherever the Work under this Contract is to be performed.
- I. Each Contractor shall arrange with Owner to make necessary alterations, do new work, make connections to all utilities, etc., at such times as will not cause interruption of utility services to facility. Contractor doing this work shall protect, cap, cut off and / or replace and relocate existing pipes, electrical work and other active utilities encountered which may interfere with new construction work.
- J. New work in extension of existing work shall correspond in all respects with that to which it connects or similar existing work unless otherwise indicated or specified.
  - 1. Existing work shall be cut, altered, removed or replaced as necessary for performance of Contract obligations.
  - 2. Work remaining in place, damaged or defaced by reason of work done under this Contract shall be restored equal to its condition at time of Award of Contract.
  - 3. If removal of work exposes discolored or unfinished surfaces or work out of alignment, such surfaces shall be refinished or materials replaced as necessary to make continuous work uniform and harmonious.

K. Contractor is not responsible for providing & maintaining temporary toilet facilities.

#### 1.27 PROTECTION

- A. Contractor shall protect from damage / injury all trees, shrubs, hedges, plantings, grass, mechanical, electrical & plumbing equipment, walks and driveways and pay for any damage to same resulting from insufficient or improper protection.
- B. Contractor shall provide and maintain barricades & signage to prohibit public access to construction site.
- C. Contractor shall provide and maintain guard lights at all barricades, railings, obstructions in streets, roads or sidewalks and at all trenches adjacent to public walks or roads.

#### 1.28 PROGRESS CLEANING

- A. Maintain areas free of waste materials, debris, and rubbish. Maintain site in clean and orderly condition.

#### 1.29 PRODUCTS

- A. Products: Means new material, machinery, components, equipment, fixtures, and systems forming the Work, but does not include machinery and equipment used for preparation, fabrication, conveying and erection of the Work. Products may also include existing materials or components specifically identified for reuse.
- B. Do not use materials and equipment removed from existing premises, except as specifically identified or allowed by Construction Documents.

#### 1.30 TRANSPORTATION, HANDLING, STORAGE AND PROTECTION

- A. Transport, handle, store and protect Products in accordance with manufacturer's instructions.

#### 1.31 PRODUCT OPTIONS

- A. Where definite material is specified, it is not intentional to discriminate against "equal" product made by another manufacturer. Intention is to set definite standard of material quality. Should bidder choose to bid materials other than those specified, bidder shall submit said materials specifications to Public Works Project Manager for approval at least seven (7) business days prior to Bid Due Date.
- B. Products and materials that are not specified, but have been approved for use by Public Works Project Manager shall be identified in addenda to all bidding contractors.
- C. Requests for material or product substitutions submitted after Bid Due Date shall not be considered. Owner reserves right to approve or reject substitutions based on Specification requirements and intended use.

### 1.32 SUBSTITUTIONS

- A. Public Works Project Manager shall consider requests for Substitutions only up to seven (7) business days prior to date of Bid Due Date.
- B. Document each request with complete data substantiating compliance of proposed Substitution with Construction Documents.
- C. Submit three (3) copies of requests for Substitution for consideration. Limit each request to one (1) proposed Substitution.
- D. Substitutions shall not change contract price established at Bid Due Date.

### 1.33 STARTING SYSTEMS

- A. Provide written notification prior to start-up of each equipment item or system.
- B. Ensure that each piece of equipment or system is ready for operation.
- C. Execute start-up under supervision of responsible persons in accordance with manufacturers' instructions.
- D. Submit written report that equipment or system has been properly installed and is functioning correctly.

### 1.34 DEMONSTRATION AND INSTRUCTIONS

- A. Demonstrate operation and maintenance of Products to Owner's personnel prior to date of final inspection.
- B. Demonstrate start-up, operation, control, adjustment, trouble-shooting, servicing, maintenance, and shutdown of each item of equipment at agreed-upon times, at designated location.
- C. Owner may choose to photograph or videotape demonstration session; demonstration and demonstrator shall be to level of satisfaction of Owner.

### 1.35 CONTRACT CLOSEOUT PROCEDURES

- A. Submit written certification that Construction Documents have been reviewed, the Work has been inspected, and the Work is complete in accordance with Construction Documents and ready for Public Works Project Manager's inspection.
- B. Submit final Application for Payment identifying total adjusted Contract Sum / Price, previous payments, and amount remaining due.

### 1.36 FINAL CLEANING

- A. Execute final cleaning prior to final inspection.

- B. Clean interior and exterior surfaces exposed to view.
- C. Remove waste and surplus materials, rubbish, and construction facilities from site.

#### 1.37 ADJUSTING

- A. Adjust operating Products and equipment to ensure smooth and unhindered operation.

#### 1.38 OPERATION AND MAINTENANCE MANUAL

- A. Provide two (2) bound, hard-copy operation and maintenance manuals that include all systems, materials, products, equipment, mechanical and electrical equipment and systems supplied and installed in the Work. Provide electronic version of operation and maintenance manual also.

#### 1.39 SPARE PARTS AND MAINTENANCE MATERIALS

- A. Provide Products, spare parts, maintenance and extra materials in quantities specified in individual Specification Sections.
- B. Deliver to the Work site and place in location as directed.

#### 1.40 AS-BUILT AND RECORD DRAWINGS AND SPECIFICATIONS

- A. Contractor-produced Drawings and Specifications shall remain property of Contractor whether Project for which they are made is executed or not. Contractor shall furnish Public Works Project Manager with original marked up redlines of Construction Documents' drawings and specifications that shall include all Addendums, Change Orders, Construction Bulletins, on-site changes, field corrections, etc. These are project As-Built Drawings & Specifications.
- B. Architect / Engineer shall update original Construction Documents to include all Addendums & any other changes including those provided by Contractor in As-Built Drawings & Specifications. These updates are project Record Drawings & Specifications.
- C. Architect / Engineer shall furnish Public Works Project Manager with Record Drawings as detailed in Professional Services Agreement.

### PART 2 PRODUCTS

Not Used.

### PART 3 EXECUTION

Not Used.



END OF SECTION

## SECTION 01 74 19

### CONSTRUCTION WASTE MANAGEMENT, DISPOSAL & RECYCLING

#### PART 1 GENERAL

##### 1.1 SUMMARY

- A. Section Includes:
  - 1. Summary
  - 2. Waste Management Goals
  - 3. Construction and / or Demolition Waste Management
  - 4. Waste Management Plan
  - 5. Reuse
  - 6. Recycling
  - 7. Materials Sorting and Storage On Site
  - 8. Lists of Recycling Facilities Processors and Haulers
  - 9. Waste Management Plan Form
  
- B. Related Sections:
  - 1. Section 01 00 00 - Basic Requirements

##### 1.2 WASTE MANAGEMENT GOALS

- A. Dane County requires that as many waste materials as possible produced as result of this project be salvaged, reused or recycled in order to minimize impact of construction waste on landfills and to minimize expenditure of energy and cost in fabricating new materials. Additional information may be found in Dane County Green Building Policy, Resolution 299, 1999-2000.

##### 1.3 CONSTRUCTION AND / OR DEMOLITION WASTE MANAGEMENT

- A. All construction and demolition waste suitable for recycling may go to Dane County Construction & Demolition Recycling Facility located at 7102 US Hwy 12, Madison, located across from Yahara Hills Golf Course. This facility can receive mixed loads of construction and demolition waste. For complete list of acceptable materials see [www.countyofdane.com/pwht/recycle/CD\\_Recycle.aspx](http://www.countyofdane.com/pwht/recycle/CD_Recycle.aspx).
- B. Dane County Landfill, also at 7102 US Hwy 12, Madison, must receive all other waste from this project. [www.countyofdane.com/pwht/recycle/landfill.aspx](http://www.countyofdane.com/pwht/recycle/landfill.aspx).

##### 1.4 WASTE MANAGEMENT PLAN

- A. Contractor shall develop Waste Management Plan (WMP) for this project. Dane County's Special Projects & Materials Manager may be contacted with questions. Outlined in RECYCLING section of this specification are examples of materials that can be recycled or reused as well as recommendations for waste sorting methods.

B. Contractor shall complete WMP and include cost of recycling / reuse in Bid. WMP will be submitted to Public Works Project Manager within fifteen (15) business days of Bid Due date. Copy of blank WMP form is in this Section. Submittal shall include cover letter and WMP form with:

1. Information on:
  - a. Types of waste materials produced as result of work performed on site;
  - b. Estimated quantities of waste produced;
  - c. Identification of materials with potential to be recycled or reused;
  - d. How materials will be recycled or reused;
  - e. On-site storage and separation requirements (on site containers);
  - f. Transportation methods; and
  - g. Destinations.

#### 1.5 REUSE

A. Contractors and subcontractors are encouraged to reuse as many waste materials as possible. Salvage should be investigated for materials not reusable on site.

#### 1.6 RECYCLING

A. These materials may be recycled at Dane County Construction & Demolition Recycling Facility:

1. Wood.
2. Wood Pallets.
3. PVC Plastic (pipe, siding, etc.).
4. Asphalt & Concrete.
5. Bricks & Masonry.
6. Vinyl Siding.
7. Cardboard.
8. Metal.
9. Unpainted Gypsum Drywall.
10. Shingles.

B. These materials can be recycled elsewhere in Dane County area:

1. Fluorescent Lamps.
2. Foam Insulation & Packaging (extruded and expanded).
3. Carpet Padding.
4. Barrels & Drums.

C. All materials must be recycled at WDNR permitted waste processing facilities that adhere to all State Statutes.

#### 1.7 MATERIALS SORTING AND STORAGE ON SITE

A. Contractor shall provide separate containers for recyclable materials. Number of containers will be dependent upon project and site conditions.

B. Contractor shall provide on-site locations for subcontractors supplied recycling containers to help facilitate recycling.

- C. Mixed loads of recycled materials are allowed only per instructions at [www.countyofdane.com/pwht/recycle/CD\\_Recycle.aspx](http://www.countyofdane.com/pwht/recycle/CD_Recycle.aspx).

#### 1.8 LISTS OF RECYCLING FACILITIES PROCESSORS AND HAULERS

- A. Refer to [www.countyofdane.com/pwht/recycle/CD\\_Recycle.aspx](http://www.countyofdane.com/pwht/recycle/CD_Recycle.aspx) for information on Dane County Construction & Demolition Recycling Facility.
- B. Web site [www.countyofdane.com/pwht/recycle/categories.aspx](http://www.countyofdane.com/pwht/recycle/categories.aspx) lists current information for Dane County Recycling Markets. Contractors can also contact Allison Hackner at 608/266-4990, or local city, village, town recycling staff listed at site [www.countyofdane.com/pwht/recycle/contacts.aspx](http://www.countyofdane.com/pwht/recycle/contacts.aspx). Statewide listings of recycling / reuse markets are available from UW Extension at <https://www.uwgb.edu/shwec/>.

#### PART 2 PRODUCTS

Not Used.

#### PART 3 EXECUTION

Not Used.

END OF SECTION

## WASTE MANAGEMENT PLAN FORM



Contractor Name: \_\_\_\_\_

Address: \_\_\_\_\_

Phone No.: \_\_\_\_\_ Recycling Coordinator: \_\_\_\_\_

MATERIAL	ESTIMATED QUANTITY	DISPOSAL METHOD (CHECK ONE)		RECYCLING / REUSE COMPANY OR DISPOSAL SITE
Salvaged & reused building materials	_____ cu. yds. _____ tons	_____ Recycled	_____ Reused	Name: _____
		_____ Landfilled	_____ Other	
Wood	_____ cu. yds. _____ tons	_____ Recycled	_____ Reused	Name: _____
		_____ Landfilled	_____ Other	
Wood Pallets	_____ units	_____ Recycled	_____ Reused	Name: _____
		_____ Landfilled	_____ Other	
PVC Plastic	_____ cu. ft. _____ lbs.	_____ Recycled	_____ Reused	Name: _____
		_____ Landfilled	_____ Other	
Asphalt & Concrete	_____ cu. ft. _____ lbs.	_____ Recycled	_____ Reused	Name: _____
		_____ Landfilled	_____ Other	
Bricks & Masonry	_____ cu. ft. _____ lbs.	_____ Recycled	_____ Reused	Name: _____
		_____ Landfilled	_____ Other	
Vinyl Siding	_____ cu. ft. _____ lbs.	_____ Recycled	_____ Reused	Name: _____
		_____ Landfilled	_____ Other	
Cardboard	_____ cu. ft. _____ lbs.	_____ Recycled	_____ Reused	Name: _____
		_____ Landfilled	_____ Other	
Metals	_____ cu. yds. _____ tons	_____ Recycled	_____ Reused	Name: _____
		_____ Landfilled	_____ Other	
Unpainted Gypsum / Drywall	_____ cu. yds. _____ tons	_____ Recycled	_____ Reused	Name: _____
		_____ Landfilled	_____ Other	
Shingles	_____ cu. yds. _____ tons	_____ Recycled	_____ Reused	Name: _____
		_____ Landfilled	_____ Other	
Fluorescent Lamps	_____ cu. ft. _____ lbs.	_____ Recycled	_____ Reused	Name: _____
		_____ Landfilled	_____ Other	
Foam Insulation	_____ cu. ft. _____ lbs.	_____ Recycled	_____ Reused	Name: _____
		_____ Landfilled	_____ Other	
Carpet Padding	_____ cu. ft. _____ lbs.	_____ Recycled	_____ Reused	Name: _____
		_____ Landfilled	_____ Other	
Barrels & Drums	_____ units	_____ Recycled	_____ Reused	Name: _____
		_____ Landfilled	_____ Other	

## WASTE MANAGEMENT PLAN FORM

Glass	_____ cu. yds. _____ tons	_____ Recycled _____ Landfilled	_____ Reused _____ Other	Name: _____
Other	_____	_____ Recycled _____ Landfilled	_____ Reused _____ Other	Name: _____
Other	_____	_____ Recycled _____ Landfilled	_____ Reused _____ Other	Name: _____
Other	_____	_____ Recycled _____ Landfilled	_____ Reused _____ Other	Name: _____
Other	_____	_____ Recycled _____ Landfilled	_____ Reused _____ Other	Name: _____
Other	_____	_____ Recycled _____ Landfilled	_____ Reused _____ Other	Name: _____

## SECTION 02 41 19

### SELECTIVE STRUCTURE DEMOLITION

#### PART 1 - GENERAL

##### 1.01 RELATED DOCUMENTS

- A. Conditions of the Contract and portions of Division One of this Project Manual apply to this Section as though repeated herein.

##### 1.02 WORK INCLUDED

- A. The work under this section shall consist of providing all work, materials, labor, equipment, and supervision necessary to provide for the demolition of such features as required in these specifications and on the drawings. Included are the following:
  1. Demolish partitions, ceilings, flooring, finishes, doors and other items as indicated.
  2. Protect portions of building adjacent to or affected by selective demolition. Take appropriate measures to protect existing facilities operations against dust contamination. Materials shall be removed from the existing building without disruption to the Owner or facility operations.
  3. Remove and legally dispose of demolished materials off-site.
  4. Demolish and salvage for reuse those items noted on the drawings.
  5. Recycle construction and demolition waste including metals and cardboard. Recycle carpet and ceiling tiles if practicable.
  6. Salvage existing door hardware for reinstallation as indicated on drawings.
  7. Salvage existing carpet to patch to match and as indicated on drawings.
  8. Salvage brick for reinstallation as indicated on drawings.

##### 1.03 RELATED WORK

- A. Recycling, Section 01 74 19.

##### 1.04 SUBMITTALS

- A. For utilities or other services requiring removal or abandonment in-place, submit materials documenting completion of such work.
- B. Submit copies of records documenting recycling of demolition materials from the site.

##### 1.05 DEFINITIONS

- A. "Remove": Remove and legally dispose of items, except those indicated to be reinstalled.
- B. "Remove and Reinstall": Remove items indicated; clean, service and otherwise prepare them for reuse; store and protect against damage. Reinstall in the same location or in locations indicated.
- C. "Existing to Remain": Protect construction indicated to remain against damage and soiling during selective demolition. When permitted by the A/E, items may be removed to a suitable, protected storage location during selective demolition and then cleaned and reinstalled in their original locations.

##### 1.06 QUALITY ASSURANCE

- A. Comply with governing codes and regulations.

1.07 RECORD DRAWINGS

- A. Maintain record drawings showing actual locations of utilities and other features encountered, and any deviations from the original design. Show actual limits of removal and demolition.

1.08 SAFETY

- A. Verify that all gas and electrical utilities have been abandoned or disconnected and associated hazards mitigated, prior to beginning any demolition.
- B. Take all necessary precautions while dismantling piping containing gas, gasoline, oil or other explosive or toxic fluids or gases. Purge lines and contain materials in accordance with all applicable regulations. Store such piping outdoors until fumes are removed.
- C. Maintain a clean and orderly site. Remove debris at end of each workday.
- D. If hazardous materials are not anticipated, but encountered, terminate operations and contact the Owner immediately. Follow all applicable local, state and federal regulations pertaining to hazardous materials.

1.09 PERMITS

- A. Unless otherwise noted, Contractor shall be responsible for obtaining and paying for all permits necessary to complete demolition work.
- B. If necessary, file and maintain Notification of Demolition and/or Renovation and Application for Permit Exemption (WDNR Form 4500-113) in accordance with the Wisconsin Administrative Code Chapter NR447.

1.010 DISCONNECTION OF SERVICES

- A. Prior to starting removal and/or demolition operations be responsible and coordinate disconnection of all existing utilities, communication systems, alarm systems and other services.
- B. Disconnect all services in manner which insures continued operation in facilities not scheduled for demolition.
- C. Disconnect all services in manner which allows for future connection to that service.
- D. Disconnect services to equipment at unions, flanges, valves, or fittings wherever possible.

1.011 REMOVAL/SALVAGING OF ITEMS

- A. Carefully remove all items that are scheduled to be salvaged.
- B. Secure salvaged items to allow for future movement; provide pallets, skids and other devices as necessary. Secure all loose parts.
- C. Provide crates, padding, tarps and other measures necessary to protect salvaged items during storage. Store items in secure location, safe from vandalism, weather, dust and other adverse elements.
- D. Where salvaged items are indicated to be turned over to Owner, deliver to location on property where designated by Owner.



- E. Where indicated to be incorporated into new work, store the salvaged item in secure location until trade responsible for re-installation mobilizes his equipment and storage facilities to the site, or otherwise accepts responsibility for the salvaged item.
- F. Items of salvage value that are not to be returned to the Owner or the A/E shall be removed from the structure. Storage or sale of such salvage items at project site is prohibited.

## PART 2 - PRODUCTS

### 2.01 EQUIPMENT

- A. Use Contractor's normal equipment for demolition purposes and which meets all safety requirements imposed on such equipment.

## PART 3 - EXECUTION

### 3.01 GENERAL

- A. Examine all areas of work, verify all existing conditions, and report any unsatisfactory conditions.

### 3.02 PROTECTION OF EXISTING WORK AND FACILITIES

- A. Verify the locations of, and protect, any building elements, utilities, and all other such facilities that are intended to remain or be salvaged.
- B. Make such explorations and probes as necessary to ascertain any required protection measures that shall be used before proceeding with demolition.
- C. Take all measures necessary to safeguard all existing work and facilities which are outside the limits of the work.
- D. Furnish and install temporary enclosures or other barriers as shown on the plans or as otherwise necessary to protect existing features.
- E. Protect adjacent interior areas from collection of dust and noxious fumes. Seal HVAC system ductwork and grilles to prevent contamination of building or mechanical systems.
- F. Provide protection for workers, public, adjacent construction and occupants of existing building(s).
- G. Report damage of any facilities or items scheduled for salvaging to the Owner.
- H. Repair or replace any damaged facilities that are not scheduled for demolition.
- I. Do not damage building elements and improvements indicated to remain.
- J. Do not close or obstruct walks, drives, other occupied or used spaces, or facilities without the written permission from the A/E and the authorities having jurisdiction.
- K. Do not interrupt utilities serving occupied facilities without permission from the A/E and authorities having jurisdiction. If necessary, provide temporary utilities.

- L. Cease operations if public safety or remaining structures are endangered. Perform temporary corrective measures until operations can be continued properly.
- M. If necessary, provide additional materials to protect existing building components that are to remain.
- N. Where necessary to prevent collapse of any construction, install temporary shores, struts or bracing. Do not commence demolition work until all temporary construction is complete.
- O. Take precautions to guard against movement, settlement or collapse of any surrounding construction designated to remain and be liable for any such movement, settlement or collapse.

### 3.03 DEMOLITION

- A. Remove all equipment, fixtures and other materials scheduled for salvage prior to beginning demolition operations.
- B. Abandon gas, electric and communication utilities in accordance with local utility company requirements, or applicable substantive requirements if considered private.
- C. Remove all sealant, fasteners and damaged or rotten blocking from existing construction to remain where demolition occurs.

### 3.04 RECYCLING

- A. Transport and dispose all demolition waste in accordance with local, state, and federal guidelines and Section 01 74 19 Recycling.

### 3.05 SCHEDULE

- A. Items to be removed shall be as indicated on the Drawings.
  - 1. Items to be stored and reinstalled.
  - 2. Items to be removed from site by Contractor.
- B. Items to remain (if clarification required).

### 3.06 CLEANING

- A. All adjacent areas shall be broom cleaned and ready to receive new construction.
- B. Remove from the site all debris resulting from the Work of this Section.

END OF SECTION 02 41 19



1 Review installation procedures of other work by Subcontractors whose work must be coordinated with the  
2 masonry work.

3  
4 The Contractor shall coordinate all work.

5  
6 Consult with all Subcontractors and material suppliers whose involvement will be affected by the work of  
7 this Section.

### 8 9 **QUALITY ASSURANCE**

10 Source Limitations for Masonry Units and Mortar Materials: One source from a single manufacturer for  
11 each product utilized.

### 12 13 **DELIVERY, STORAGE AND HANDLING**

14 Store masonry units on elevated platforms in a dry location. If units are not stored in an enclosed location,  
15 cover tops and sides of stacks with waterproof sheeting, securely tied. If units become wet, do not install  
16 until they are dry.

17  
18 Store cementitious materials on elevated platforms, under cover, and in a dry location. Do not use  
19 cementitious materials that have become damp or contaminated.

20  
21 Store aggregates where grading and other required characteristics can be maintained and contamination  
22 avoided.

23  
24 Deliver preblended, dry mortar mix in moisture-resistant containers designed for lifting and emptying into  
25 dispensing silo. Store preblended, dry mortar mix in delivery containers on elevated platforms, under  
26 cover, and in a dry location or in a metal dispensing silo with weatherproof cover.

27  
28 Store masonry accessories, including metal items, to prevent corrosion and accumulation of dirt and oil.

### 29 30 **PROJECT/SITE CONDITIONS**

31 Stain Prevention: Prevent grout, mortar, and soil from staining the face of masonry to be left exposed.  
32 Immediately remove grout, mortar, and soil that come in contact with such masonry. Protect base of walls  
33 from mortar splatter by spreading coverings on ground and over wall surface. Protect floor from mortar  
34 droppings. Protect surfaces of door frames and steel channel with painted and integral finishes, from  
35 mortar droppings.

## 36 37 **PART 2 - PRODUCTS**

### 38 39 **MASONRY UNITS, GENERAL**

40 Provide special shapes or sizes as indicated on the Drawings or where cutting of units would expose the cut  
41 in the completed work.

42  
43 Referenced masonry unit standards allow a certain percentage of units to exceed tolerances and to contain  
44 chips, cracks or other imperfections exceeding limits stated in the standard. Do not use units where such  
45 imperfections, including tolerances that vary more than the amount stated in the standard, will be exposed  
46 in the completed Work.

### 47 48 **CONCRETE MASONRY UNITS**

49 Materials and Physical Properties: Concrete block units shall be made from materials and manufactured to  
50 comply with all applicable requirements of ASTM C90, Solid Units of Normal Weight, typically cored. No  
51 integral water repellent is permitted.

52  
53 Source: All units shall be from one source and of uniform color and texture.

54  
55 Size: Concrete block units shall be 7-5/8" x 15-5/8" x thickness indicated on Drawings. Concrete brick  
56 may be of size as appropriate to facilitate the work. Field verify and match existing masonry.

57  
58 Special Shapes: Provide where required for corners, jambs or other special conditions specifically  
59 indicated including applications which cannot be produced by cutting of standard size units.

60  
61 Protection: Concrete masonry units shall be protected from the elements for a minimum time of seven days  
62 immediately prior to being incorporated into the Work.

1 **MORTAR AND GROUT MATERIALS**

2 Field verify, match existing brick mortar.

3 Portland Cement: Shall conform to ASTM C150, Type I. Only one brand and kind of Portland cement  
4 from one source shall be used for the work unless prior written approval is obtained from the A/E. Brands  
5 are subject to approval of the A/E based upon the mortar color desired and obtainable by use of the various  
6 brands readily available. No white cement or nonstaining cement will be required.

7  
8 Lime: Shall be pressure-hydrated, non air-entrained and conform to ASTM C207, Type S.

9  
10 Masonry Sand: Shall be clean, sharp, free from loam, silt, vegetable matter, salts, and other injurious  
11 substances, and shall conform to ASTM C144. Sand is further subject to approval of the A/E, based on  
12 mortar color desired and obtainable by use of local sands readily available, and shall be from one source.

13  
14 Aggregate for Grout: ASTM C404.

15  
16 Water: Shall be potable, fresh, clean, clear, and free of injurious amounts of oil, acid, alkali, salts, organic  
17 matter or other detrimental substances, and handled in clean containers.

18  
19 Plasticizer: Not permitted.

20  
21 Water Repellent: Not permitted.

22  
23 Coloring Pigments: Not permitted.

24  
25 Other Admixtures: Shall not be used at any time and will not be knowingly approved. Use of special air-  
26 entraining admixtures, chlorides or nitrates, with or without approval, will be sufficient cause to require  
27 removal and replacement of all masonry work containing or treated with same.

28  
29 The autoclave expansion of the cementitious portion of the mortar materials, when mixed in proportions  
30 required under "mortar mixes," shall not exceed one-half percent when tested according to ASTM C151.  
31 The air content of any mortar required under "mortar mixes" shall not exceed six percent when tested  
32 according to ASTM C231 and/or ASTM C173 and/or ASTM C457.

33  
34 Fully or partial premixed mortar materials will be considered for approval when each requirement of the  
35 individual materials is complied with and is so stated on the container, or certified, along with proportions  
36 and quantities.

37  
38 **INDIVIDUAL TIES AND ANCHORS:**

39 Materials and Coatings: Provide galvanized (zinc coated) steel units conforming to Class B requirements  
40 of ASTM A153, unless otherwise specified.

41  
42 Juncture of Concrete Masonry Back-up with Concrete Columns: Provide corrugated dovetail tie 1" wide  
43 by 12 gauge by 5-1/2" long, fitted to 12 gauge dovetail anchor; equivalent to Hohmann & Barnard, Inc.  
44 # 303 corrugated dovetail brick tie with mill galvanized finish.

45  
46 **MORTAR MIXES**

47 Conventional Job Mixed Mortar: Measure materials for mortars by volume, in a manner whereby  
48 proportions can be controlled within two percent. Mix materials dry and then water to bring to proper  
49 consistency for use. Mix materials in the approved type machine mixer of adequate capacity for 3 to 5  
50 minutes after all materials have been introduced, until materials are evenly distributed throughout the batch  
51 and the mixture is uniform in color with a workable consistency.

52  
53 Silo Metered and Bulk Container Mortar: Shall comply with ASTM C1714. Use materials specified  
54 hereinbefore and proportion mixes as specified hereinafter. Add water and mix according to system  
55 manufacturer's recommendations.

56  
57 Use maximum water consistent with good workability and freedom from smearing the face of masonry  
58 work. Use no mortar that has stood more than one hour after initial mixing. Mortar less than one hour old  
59 shall be reasonably retempered as necessary to maintain its workability, but used before it is one hour old  
60 or otherwise discarded. No anti-freeze ingredient or contaminate of any type will be permitted.

61

1 Mortar for Concrete Block: Shall be ASTM C270, Type N, Cement-Lime Mortar conforming to the  
2 proportion specification requirements. (1:1:6).

3  
4 The proportions listed above are Portland cement, lime, damp loose sand, respectively by volume. The  
5 proportions are listed only as samples for the required type mortars and shall be modified as necessary,  
6 within tolerances, to suit the particular masonry sand being used.  
7

### 8 **PART 3 - EXECUTION**

#### 9 **EXAMINATION**

10 Examine Work of other Section Contractors on which or to which unit masonry is to be built, supported or  
11 attached, to determine completeness and proper alignment to receive unit masonry. Do not commence  
12 masonry work until all related noncompliant work has been corrected.  
13

14  
15 Before installation of masonry, examine rough-in and built-in construction for piping systems to verify  
16 actual locations of piping connections.  
17

#### 18 **PREPARATION**

19 Verify that items provided by other Section Contractors are properly sized and located.  
20

21 Verify that anchorages embedded in concrete are properly placed.  
22

23 Establish lines, levels, and coursing. Protect from disturbance.  
24

25 Provide temporary bracing during erection of masonry work. Maintain in place until building structure  
26 provides permanent bracing.  
27

#### 28 **INSTALLATION, GENERAL**

29 Build interior concrete masonry walls to actual width of masonry units using units of widths indicated.  
30

31 Leave openings for equipment to be installed before completing masonry. After equipment is installed,  
32 complete masonry to match the construction immediately adjacent to opening.  
33

34 Use full size units without cutting where possible. If cutting is required to provide a continuous pattern or  
35 to fit adjacent construction, cut units with motor-driven saws to provide cuts that are straight and true,  
36 resulting in clean, sharp unchipped edges of the units. Allow typical cut units to surface dry before laying.  
37 Install cut units with cut surfaces and, where possible, cut edges concealed.  
38

39 Select and arrange units for exposed masonry to produce a uniform blend of colors and textures.  
40

#### 41 **TOLERANCES**

42 Dimensions and Locations of Elements: For dimensions in cross section or elevation do not vary by more  
43 than minus 1/4 inch or plus 1/2 inch.  
44

45 For location of elements in plan do not vary from that indicated by more than minus  $\pm$  1/2 inch in 20 feet or  
46  $\pm$  3/4 inch total.  
47

48 For location of elements in elevation do not vary from that indicated by more than  $\pm$  1/4 inch in a story  
49 height or  $\pm$  3/4 inch total.  
50

51 Lines and Levels: For bed joints, do not vary from level by more than  $\pm$  1/4 inch in 10 feet, or  $\pm$  1/2 inch  
52 maximum.  
53

54 For horizontal lines, do not vary from level by more than 1/4 inch in 10 feet, 3/8 inch in 20 feet, or 1/2 inch  
55 maximum.  
56

57 For vertical lines and surfaces, do not vary from plumb by more than 1/4 inch in 10 feet, 3/8 inch in 20 feet,  
58 or 1/2 inch maximum. Total vertical alignment of exposed head joints may have double these tolerances.  
59

60 For lines and surfaces, do not vary from straight or plane by more than 1/4 inch in 10 feet, 3/8 inch in  
61 20 feet, or 1/2 inch maximum.  
62

63 For faces of adjacent exposed masonry units, do not vary from flush alignment by more than  $\pm$  1/8 inch.  
64

1 Joints: For bed joints, do not vary from thickness indicated by more than  $\pm 1/8$  inch.

2  
3 For head and collar joints, do not vary from thickness indicated by more than minus  $1/4$  inch or plus  
4  $3/8$  inch.

5  
6 If the above tolerances cannot be met due to previous construction, notify the A/E.

### 7 8 **LAYING MASONRY WYTHES**

9 Lay out walls in advance for alignment of head joints with uniform joint thicknesses and for accurate  
10 location of openings, movement joints, returns, and offsets. Maintain horizontal joint plane through all  
11 wythes of masonry. Fully bond intersections, and external and internal corners. Avoid using less-than-  
12 half-size units, particularly at corners, jambs, and, where possible, at other locations.

13  
14 Bond Pattern for All Masonry: Lay masonry in  $1/2$  running bond. Bond and interlock each course of each  
15 wythe at corners. Do not use units with less than nominal 4 inch horizontal face dimensions at corners or  
16 jambs.

17  
18 Adjusting Units: Adjust the final position of each masonry unit while the mortar is still plastic. To replace  
19 or reposition a unit after mortar has begun to set, remove the unit, replace the mortar with plastic mortar,  
20 and replace the unit.

21  
22 Tooling: Tool all mortar joints exposed in the finished work, including the bed joints.

23  
24 Tool exposed joints when "thumb-print" hard with a round jointer, slightly larger than width of joint and of  
25 sufficient length to obtain a straight and true mortar joint. Tooling shall be performed so that the mortar is  
26 compressed and the joint surface is sealed and in intimate contact with the edge of the masonry unit. This  
27 may require some craft persons to complete work after normal working hours. All crafts persons involved  
28 in the project shall utilize new hardened steel jointers of the same size when beginning to lay masonry on  
29 the project.

30  
31 Stopping and Resuming Work: Stop off horizontal run of masonry by racking back  $1/2$  length of unit in  
32 each course from those in course below. Do not tooth except where necessary around openings. When  
33 resuming work, clean masonry surfaces that are to receive mortar, remove loose masonry units and mortar.

34  
35 Built-in Work: As construction progresses, build in items specified in this and other Sections. Include  
36 built-in metal frames, anchor bolts, reglets, and other items to be built into the work supplied by other  
37 Section Contractors. Bed anchors of hollow metal frames in mortar joints. Build in items plumb and level.  
38 Fill in solidly with masonry around built-in items. Use ASTM C 476 grout or job mortar with high flow to  
39 slush full voids between masonry and hollow metal door frames.

40  
41 Cutting and Fitting: Cut and fit masonry units for steel channels, door and openings. Cooperate fully with  
42 other Contractors to ensure correct size, shape and location.

43  
44 Where built-in items are to be embedded in cores of hollow masonry units, place a layer of metal lath, wire  
45 mesh, or plastic mesh in the joint below and rod mortar or grout into the core.

46  
47 Fill cores in concrete masonry units directly under lintels with mortar or grout.

48  
49 Fill cores in concrete masonry units with mortar or grout above and below where portions of anchors are to  
50 be installed.

### 51 52 **MORTAR BEDDING AND JOINTING**

53 For Concrete Masonry Units: Lay units with face shells fully bedded in mortar and with head joints of  
54 depth equal to bed joints. For starting courses on concrete, lay units fully bedded in mortar, including areas  
55 under cells.

56  
57 Bed and head joints in masonry shall be of a nominal  $3/8$  inch thickness.

### 58 59 **MASONRY JOINT REINFORCEMENT**

60 Install entire length of longitudinal wire in mortar bed joints with a minimum cover of  $3/4$  inch on exterior  
61 side of walls.

62  
63 Do not bend typical continuous masonry joint reinforcement in the construction process.

1 Lap continuous masonry joint reinforcement ends a minimum of 6 inches.

2  
3 Space continuous masonry joint reinforcement a minimum of 16 inches on center vertically.

4  
5 Provide reinforcement no more than 8 inches above and below wall openings and extending 12 inches  
6 beyond openings. Such reinforcement is in addition to continuous reinforcement when not coincident.

7  
8 Interrupt joint reinforcement in a wythe wherever a movement joint occurs.

9  
10 Provide continuity at concrete masonry wall intersections by using prefabricated T-shaped units or wire  
11 mesh with cores filled.

12  
13 Provide continuity at corners by using prefabricated L-shaped units.

#### 14 15 **REPAIRING AND POINTING**

16 Remove and replace to A/E's satisfaction masonry units that are loose, chipped, broken, stained, or  
17 otherwise damaged or that do not match adjoining units as intended. Install new units to match adjoining  
18 units and install in fresh mortar, pointed to eliminate evidence of replacement.

19  
20 Pointing: During the tooling of joints, enlarge voids and holes, except weep holes, and completely fill with  
21 mortar. Point up joints, including corners, openings, and adjacent work, to provide a neat, uniform  
22 appearance. Prepare joints for sealant application, where indicated.

#### 23 24 **LAYING, PROTECTION AND CLEANING**

25 All masonry shall be in final acceptance condition within 24 hours after laying and shall be maintained in  
26 that condition, by meeting or exceeding the degree of cleanliness required, demonstrated on the approved  
27 sample panel.

28  
29 Lay masonry utilizing all necessary care to achieve cleanliness. Remove excess mortar from exposed  
30 exterior and interior masonry surfaces as the work progresses and before it tenaciously adheres to the faces  
31 of the masonry. Remove mortar protrusions and smears as masonry units are laid and tooled, as scaffolds  
32 are raised, and at the start of the next day's work, leaving the surface of the masonry clean and finished.  
33 Use calcimine brushes, stiff fiber brushes, other similar masonry units, burlap, rags, carpet remnants,  
34 rubber floats, or other approved means. (Cleaning of masonry the morning after laying by the same masons  
35 who laid the masonry the previous day, using stiff fiber brushes with or without water and sand, and  
36 concentrating on cleaning the field of the masonry units has also been successfully used to achieve an  
37 appearance matching or exceeding the cleanliness of the approved sample panel.) Use of chemical  
38 cleaning or harsh physical cleaning will not be permitted. Included as chemical cleaners and prohibited are  
39 most manufactured masonry cleaning solutions or compounds. Equipment or methods and techniques  
40 utilized, reduced productivity, as well as weather conditions experienced will not relieve this Section  
41 contractor of required compliance.

42  
43 Protection shall be provided to prevent mortar spattering and maintain masonry in a clean condition so that  
44 the masonry is satisfactory for acceptance when masonry work is completed. This may require covering  
45 portions of finished masonry which is below new work in progress with polyethylene, canvas, or other  
46 approved means. Extend covering a minimum of 24 inches down both sides of wall, and hold covering  
47 securely in place. Hair-pin type devices frequently spaced have been successfully used in the past. When  
48 practical, lay masonry from the top floor down.

49  
50 No final washdown is required unless removal of earthy construction dirt or dust is necessitated by  
51 extremely unusual site conditions.

#### 52 53 **MASONRY WASTE DISPOSAL**

54 Excess masonry materials are this Section contractor's property and shall be removed from the Project site  
55 upon completion of unit masonry work.

56  
57  
58 **END OF SECTION**



SECTION 04 43 00

STONE MASONRY

PART 1 - GENERAL

1.01 RELATED DOCUMENTS

- A. Applicable provisions of Division 1 shall govern all work under this section.

1.02 WORK INCLUDED

- A. Anchorage and setting systems.
- B. Accessories.

1.03 RELATED SECTIONS

- A. Section 04 05 19 Masonry Accessories
- B. Section 04 20 00 Unit Masonry
- C. Section 07 92 00 Joint Sealants

1.04 QUALITY ASSURANCE

- A. Manufacturer shall have minimum of five years production experience in work of quality and scope required on this Project.
- B. Each color, grade, finish, type, and variety of stone shall be from a single quarry with sufficient resources to furnish materials of consistent quality, appearance, and physical properties.
- C. All units, setting methods and finish shall be in strict accordance with Industry Standards and Practices set forth by the Indiana Limestone Institute of America.

1.05 SUBMITTALS

- A. Submit in accord with the general conditions of this contract.
- B. Product Data: For each type of product indicated.
- C. Shop Drawings:
  - 1. Shop Drawings shall be complete and shall include a layout plan, fabrication details, connection and anchorage details, location of lifting devices, and member identification marks. The identification marks shall appear on the manufactured units to facilitate correct field placement. Manufacturer's standard hardware will be clearly described.
- D. Samples:
  - 1. Submit three 12 inch x 12 inch samples representative of finished units showing full range of color and texture.
- E. Mock-up:
  - 1. Provide a mock-up including entire wall system for AE approval prior to continuing work.

- 1 F. Installer Qualifications: A qualified installer who employs experienced stonemasons and stone  
2 fitters. Minimum 10 years experience.  
3
- 4 G. Source Limitations for Stone: Obtain stone, regardless of finish, from one quarry with resources  
5 to provide materials of consistent quality in appearance and physical properties.  
6
- 7 H. Source Limitations for Mortar Materials: Obtain mortar ingredients of a uniform quality,  
8 including color for exposed masonry, from single manufacturer for each cementitious  
9 component and from single source or producer for each aggregate.

10  
11 1.06 DELIVERY, STORAGE AND HANDLING  
12

- 13 A. Transport and handle with proper equipment to protect units from dirt and damage. Place non-  
14 staining resilient spacers of even thickness between each unit. Units shall be palletized.  
15
- 16 B. Store to protect units from contact with soil or ground. Store units on firm surfaces to avoid  
17 warping and cracking. Place stored units so that identification marks are discernible.  
18

19 1.07 PROJECT CONDITIONS  
20

- 21 A. Protection of Stone Masonry: During construction, cover tops of walls, projections, and sills  
22 with waterproof sheeting at end of each day's work. Cover partially completed stone masonry  
23 when construction is not in progress.  
24 1. Extend cover a minimum of 24 inches down both sides and hold cover securely in place.  
25
- 26 B. Stain Prevention: Immediately remove mortar and soil to prevent them from staining the face of  
27 stone masonry.  
28 1. Protect base of walls from rain-splashed mud and mortar splatter by coverings spread on  
29 the ground and over the wall surface.  
30 2. Protect sills, ledges, and projections from mortar droppings.  
31 3. Protect surfaces of window and door frames, as well as similar products with painted and  
32 integral finishes, from mortar droppings.  
33 4. Turn scaffold boards near the wall on edge at end of each day to prevent rain from  
34 splashing mortar and dirt on completed stone masonry.  
35
- 36 C. Cold-Weather Requirements: Do not use frozen materials or materials mixed or coated with ice  
37 or frost. Do not build on frozen substrates. Remove and replace stone masonry damaged by  
38 frost or freezing conditions.  
39 1. Comply with cold-weather construction requirements contained in  
40 ACI 530.1/ASCE 6/TMS 602.  
41 2. Cold-Weather Cleaning: Use liquid cleaning methods only when air temperature is 40  
42 deg F and above and will remain so until masonry has dried, but not less than 7 days  
43 after completing cleaning.  
44
- 45 D. Hot-Weather Requirements: Comply with hot-weather construction requirements contained in  
46 ACI 530.1/ASCE 6/TMS 602.  
47

48 1.08 ENVIRONMENTAL REQUIREMENTS  
49

- 50 A. Recycled content: Provide products manufactured from recycled content as specified.  
51 1. Stainless steel anchors: Minimum 60% pre consumer.  
52 2. Fasteners: Minimum 60% pre consumer.  
53 3. Metal flashing: Minimum 12% post-consumer recycled content.  
54
- 55 B. Regional Materials: Provide materials or products that have been extracted, harvested, or  
56 recovered, as well as manufactured, within 500 miles of the project site.

1  
2  
3  
4  
5  
6  
7  
8  
9  
10  
11  
12  
13  
14  
15  
16  
17  
18  
19  
20  
21  
22  
23  
24  
25  
26  
27  
28  
29  
30  
31  
32  
33  
34  
35  
36  
37  
38  
39  
40  
41  
42  
43  
44  
45  
46  
47  
48  
49  
50  
51  
52  
53  
54  
55  
56

1.09 COORDINATION

- A. Advise installers of other work about specific requirements for placement of reinforcement, veneer anchors, flashing, and similar items to be built into stone masonry.

PART 2 - PRODUCTS

2.01 LIMESTONE

- A. Limestone: Comply with ASTM C 568.
  - 1. Products: Subject to compliance with requirements, stone varieties to be incorporated into the Work include the following:
    - a. Indiana Oolitic Limestone, classification II (medium-density).
    - b. Sizes as indicated on drawings.
    - c. Color to match existing gray/buff color of existing limestone.
    - d. Finish smooth.

2.02 ANCHORS

- A. Veneer Anchors
  - 1. Materials:
    - a. Hot dipped galvanized.
  - 2. Size: Sufficient to extend at least halfway, but not less than 1-1/2 inches, through stone masonry and with at least 5/8-inch cover on outside face.
  - 3. Provide veneer anchors, dowels, and fasteners as required by various conditions.
    - a. Dowels to be equal to Heckman 155, hot dipped galvanized, 3/8" diameter at sill pieces. by length required to securely anchor stone to back-up.
  - 4. Structural Performance Characteristics: Capable of withstanding a 100-lbf load in both tension and compression without deforming or developing play in excess of 0.05 inch.

2.03 EMBEDDED FLASHING MATERIALS

- A. Metal Flashing: Provide metal flashing, where flashing is exposed or partly exposed and where indicated, complying with SMACNA's "Architectural Sheet Metal Manual and Division 7 Section "Sheet Metal Flashing and Trim" and as follows:
  - 1. 20 ga. hot dipped galvanized or Aluminum to match section 08 41 13 Aluminum-Entrances and Storefronts. Provide fully coordinated shop drawing submittals.
  - 2. Fabricate continuous flashings in sections 96 inches (2400 mm) long minimum, but not exceeding 12 feet. Provide splice plates at joints of formed, smooth metal flashing.
  - 3. Flashings are to project a minimum of 3/4" from the face of the wall, be bent down at a 45 degree angle to cause water to flow away from the wall and shall be hemmed.
- B. Concealed portion of flashing shall have a minimum 4" vertical back dam; bend between back dam and horizontal shall be slightly greater than 90 degrees. End dams shall be a minimum of 1-1/2" in height.
- C. Provide prefabricated continuous pieces at all internal/external corners; pieces shall be a minimum of 18" in length, in both directions from the corner.
- D. Notch and lap joints 3" between sections. Apply a continuous bead of sealant within the lap.
- E. Slope flashing to drain with masonry grout under horizontal portion of flashing.

1  
2 F. Fabricate through-wall flashing with drip edge unless otherwise indicated. Fabricate by  
3 extending flashing 3/4 inch out from wall, with outer edge bent down 30 degrees and hemmed.  
4

5 G. At caps, sills, copings, etc. flashing is to project from the wall a minimum of 1 1/2" and shall be  
6 hemmed.  
7

8 2.04 MISCELLANEOUS MASONRY ACCESSORIES  
9

10 A. Compressible Filler: Pre-molded filler strips complying with ASTM D 1056, Grade 2A1;  
11 compressible up to 35 percent; of width and thickness indicated; formulated from urethane.  
12

13 B. Water: Potable.  
14

15 2.05 MORTAR MIXES  
16

17 A. General: As specified in Section 04 01 00.  
18

19 2.06 FABRICATION  
20

21 A. Fabricate stone to comply with sizes, shapes, and tolerances recommended by applicable stone  
22 association or, if none, by stone source, for faces, edges, beds, and backs.  
23

24 B. For limestone, comply with recommendations in ILI's "Indiana Limestone Handbook."  
25

26 1. Cut and select stone to produce pieces of thickness, size, and shape indicated, including  
27 details on Drawings. Dress joints (bed and vertical) straight and at right angle to face  
28 unless otherwise indicated.

29 2. Cut and drill sinkages and holes in stone for anchors and supports.  
30

31 3. Carefully inspect stone at quarry or fabrication plant for compliance with requirements  
32 for appearance, material, and fabrication. Replace defective units before shipment.

33 4. Clean sawed backs of stone to remove rust stains and iron particles.  
34

35 C. Thickness of Stone: Provide thickness indicated, but not less than the following:  
36

37 1. Thickness: 4 inches plus or minus 1/8 inch. Thickness does not include projection of  
38 pitched faces.  
39

40 D. Shape stone to match the existing profiles, details and tooling of sound units.  
41

42 1. If existing units are eroded or details are missing, provide profiles and details with sharp  
43 edges and whole details to approximate original shapes.  
44

45 PART 3 - EXECUTION  
46

47 3.01 EXAMINATION  
48

49 A. Examine surfaces indicated to receive stone masonry, with Installer present, for compliance with  
50 requirements for installation tolerances and other conditions affecting performance.  
51

52 B. Examine substrate to verify that dovetail slots, inserts, reinforcement, veneer anchors, flashing,  
53 and other items installed in substrates and required for or extending into stone masonry are  
54 correctly installed.  
55

56 C. Proceed with installation only after unsatisfactory conditions have been corrected.  
57

58 3.02 PREPARATION  
59

60 A. Coordinate delivery, erection of units.  
61

1  
2  
3  
4  
5  
6  
7  
8  
9  
10  
11  
12  
13  
14  
15  
16  
17  
18  
19  
20  
21  
22  
23  
24  
25  
26  
27  
28  
29  
30  
31  
32  
33  
34  
35  
36  
37  
38  
39  
40  
41  
42  
43  
44  
45  
46  
47  
48  
49  
50  
51  
52  
53  
54  
55  
56

B. Protect the work and material of other trades during installation of units.

3.03 INSTALLATION

- A. Transportation, Site Handling, Erection: Performed with acceptable equipment methods, by qualified personnel acceptable to Indiana Limestone Institute of America.
- B. Set units in full bed of mortar. Leave 3/8 inch space for end joints. Install backer rod and sealant.
- C. Embed veneer anchors in mortar joints of stone masonry at least halfway, but not less than 1-1/2 inches, through stone masonry and with at least 5/8-inch cover on outside face.
- D. Space anchors not more than 18 inches o.c. vertically and 24 inches o.c. horizontally, 32" if units are 16", with not less than 1 anchor per 2.67 sq. ft. of wall area. Install additional anchors within 12 inches of openings, sealant joints, and perimeter at intervals not exceeding 12 inches.
- E. Install embedded flashing shelf angles, lintels, ledges, other obstructions to downward flow of water in wall, and where indicated.
  - 1. At multi-wythe masonry walls, extend flashing through stone masonry, turned up a minimum of 8 inches, and attached to concrete backup with continuous termination bar and sealant.
  - 2. At lintels and shelf angles, extend flashing full length of angles but not less than 6 inches into masonry at each end.
  - 3. At sills, extend flashing not less than 4 inches at ends.
  - 4. At ends of head and sill flashing turn up not less than 2 inches to form end dams.
  - 5. Extend sheet metal flashing 3/4 inch beyond face of masonry at exterior and turn flashing down to form a 3/4 inch hemmed drip.
- F. Place and align the members in final position in the structure on the accepted bearing surfaces.

3.04 CLEANING

- A. After all installation procedures, including joint treatment are completed, clean exposed faces of units.
- B. All masonry shall be in final acceptance condition within 24 hours after laying and shall be maintained in that condition, by meeting or exceeding the degree of cleanliness required, demonstrated on the approved sample panel.
- C. Lay masonry utilizing all necessary care to achieve cleanliness. Remove excess mortar from exposed exterior and interior (stone, clay, concrete and other) masonry surfaces as the work progresses and before it tenaciously adheres to the faces of the masonry.
  - 1. Remove mortar protrusions and smears as masonry units are laid and tooled, as scaffolds are raised, and at the start of the next day's work, leaving the surface of the masonry clean and finished.
  - 2. Contractor may use calcimine brushes, stiff fiber brushes, other similar masonry units, burlap, rags, carpet remnants, rubber floats or other approved means. (Cleaning of masonry the morning after laying by the same masons who laid the masonry the previous day, using stiff fiber brushes with or without water and sand, concentrating on cleaning the field of the masonry units, has also been successfully used to achieve an appearance matching or exceeding the cleanliness of the approved sample panel.)
  - 3. **USE OF CHEMICAL CLEANING OR HARSH PHYSICAL CLEANING WILL NOT BE PERMITTED.** Included are chemical cleaners and most manufactured masonry cleaning solutions or compounds. Approval of DSF Representative is required before anything other than potable water is used.



SECTION 05 12 00

STRUCTURAL STEEL FRAMING

PART 1 - GENERAL

1.01 RELATED DOCUMENTS

- A. Drawings and general provisions of the Contract, including General and Supplementary Conditions and Division 01 Specification Sections, apply to this Section.

1.02 WORK INCLUDED

- A. Structural Steel
- B. Grout

1.03 RELATED WORK

- A. Miscellaneous Metal Fabrications: Section 05 50 00 Metal Fabrications
- B. Exterior Painting: Section 09 90 00 Exterior Painting
- C. High-Performance Coatings: Section 09 96 00 High-Performance Coatings

1.04 SUBMITTALS

- A. Product Data: For each type of product.
- B. Shop Drawings: Show fabrication of structural-steel components.
  - 1. Include details of cuts, connections, splices, camber, holes, and other pertinent data.
  - 2. Include embedment Drawings.
  - 3. Indicate welds by standard AWS symbols, distinguishing between shop and field welds, and show size, length, and type of each weld. Show backing bars that are to be removed and supplemental fillet welds where backing bars are to remain.
  - 4. Indicate type, size, and length of bolts, distinguishing between shop and field bolts. Identify pretensioned and slip-critical, high-strength bolted connections.
- C. Paint Compatibility Certificates: From manufacturers of topcoats applied over shop primers, certifying that shop primers are compatible with topcoats.
- D. Product Test Reports: For the following:
  - 1. Bolts, nuts, and washers including mechanical properties and chemical analysis.
  - 2. Tension-control, high-strength, bolt-nut-washer assemblies.
  - 3. Shear stud connectors.
  - 4. Shop primers.
  - 5. Nonshrink grout.

1.05 QUALITY ASSURANCE

- A. Shop-Painting Applicators: Qualified according to AISC's Sophisticated Paint Endorsement P1, Endorsement P2, or Endorsement P3, or to SSPC-QP 3, "Standard Procedure for Evaluating Qualifications of Shop Painting Applicators."

57 B. Welding Qualifications: Qualify procedures and personnel according to AWS D1.1/D1.1M, "Structural  
58 Welding Code - Steel."  
59

60 1. Welders and welding operators performing work on bottom-flange, demand-critical welds shall pass  
61 the supplemental welder qualification testing, as required by AWS D1.8/D1.8M. FCAW-S and  
62 FCAW-G shall be considered separate processes for welding personnel qualification.  
63

64 C. Comply with applicable provisions of the following specifications and documents:  
65

66 D. Retain references in subparagraphs below if applicable. Insert others to suit Project.  
67

68 1.06 DELIVERY, STORAGE, AND HANDLING  
69

70 A. Store materials to permit easy access for inspection and identification. Keep steel members off ground and  
71 spaced by using pallets, dunnage, or other supports and spacers. Protect steel members and packaged  
72 materials from corrosion and deterioration.  
73

74 1. Do not store materials on structure in a manner that might cause distortion, damage, or overload to  
75 members or supporting structures. Repair or replace damaged materials or structures as directed.  
76

77 B. Store fasteners in a protected place in sealed containers with manufacturer's labels intact.  
78

79 1. Fasteners may be repackaged provided Owner's testing and inspecting agency observes repackaging  
80 and seals containers.

81 2. Clean and relubricate bolts and nuts that become dry or rusty before use.

82 3. Comply with manufacturers' written recommendations for cleaning and lubricating ASTM F 1852  
83 fasteners and for retesting fasteners after lubrication.  
84

85 PART 2 - PRODUCTS  
86

87 2.01 PERFORMANCE REQUIREMENTS  
88

89 A. Connections: Provide details of simple shear connections required by the Contract Documents to be  
90 selected or completed by structural-steel fabricator to withstand loads indicated and comply with other  
91 information and restrictions indicated.  
92

93 2.02 STRUCTURAL-STEEL MATERIALS  
94

95 A. W-Shapes: ASTM A 992.  
96

97 B. Channels, Angles Shapes: ASTM A 36.  
98

99 C. Plate and Bar: ASTM A 36.  
100

101 D. Cold-Formed Hollow Structural Sections: ASTM A 500/A 500M, Grade B, structural tubing.  
102

103 E. Welding Electrodes: Comply with AWS requirements.  
104

105 2.03 BOLTS, CONNECTORS, AND ANCHORS  
106

107 A. High-Strength Bolts, Nuts, and Washers: ASTM A 325, Type 1, heavy-hex steel structural bolts;  
108 ASTM A 563, Grade C, heavy-hex carbon-steel nuts; and ASTM F 436, Type 1, hardened carbon-steel  
109 washers; all with plain finish.  
110



111 B. Tension-Control, High-Strength Bolt-Nut-Washer Assemblies: ASTM F 1852, Type 1, heavy-hex or round  
112 head assemblies consisting of steel structural bolts with splined ends, heavy-hex carbon-steel nuts, and hardened  
113 carbon-steel washers.

114  
115 1. Finish: Plain

116  
117 C. Threaded Rods: ASTM F 1554 Grade 36

118  
119 1. Nuts: ASTM A 563 heavy-hex carbon steel.  
120 2. Washers: ASTM F 436, Type 1, hardened carbon steel.  
121 3. Finish: Plain (interior) and Hot Dipped Galvanized (exterior exposed to weather) ASTM A153,  
122 CLASS C.

123  
124 D. Primer: Comply with Section 09 90 00 "Exterior Painting" and Section 09 96 00 "High-Performance  
125 Coatings."

126  
127 2.04 GROUT

128  
129 A. Nonmetallic, Shrinkage-Resistant Grout: ASTM C 1107/C 1107M, factory-packaged, nonmetallic  
130 aggregate grout, noncorrosive and nonstaining, mixed with water to consistency suitable for application  
131 and a 30-minute working time.

132  
133 2.05 FABRICATION

134  
135 A. Structural Steel: Fabricate and assemble in shop to greatest extent possible. Fabricate according to  
136 AISC 303, "Code of Standard Practice for Steel Buildings and Bridges," and to AISC 360.

137  
138 1. Camber structural-steel members where indicated.  
139 2. Fabricate beams with rolling camber up.  
140 3. Identify high-strength structural steel according to ASTM A 6/A 6M and maintain markings until  
141 structural steel has been erected.  
142 4. Mark and match-mark materials for field assembly.  
143 5. Complete structural-steel assemblies, including welding of units, before starting shop-priming  
144 operations.

145  
146 B. Thermal Cutting: Perform thermal cutting by machine to greatest extent possible.

147  
148 1. Plane thermally cut edges to be welded to comply with requirements in AWS D1.1/D1.1M.

149  
150 C. Bolt Holes: Cut, drill, or punch standard bolt holes perpendicular to metal surfaces.

151  
152 D. Finishing: Accurately finish ends of columns and other members transmitting bearing loads.

153  
154 E. Cleaning: Clean and prepare steel surfaces that are to remain unpainted according to SSPC-SP 2, "Hand  
155 Tool Cleaning"

156  
157 2.06 SHOP CONNECTIONS

158  
159 A. High-Strength Bolts: Shop install high-strength bolts according to RCSC's "Specification for Structural  
160 Joints Using ASTM A 325 or A 490 Bolts" for type of bolt and type of joint specified.

161  
162 1. Joint Type: Snug tightened.

163  
164 B. Weld Connections: Comply with AWS D1.1/D1.1M for tolerances, appearances, welding procedure  
165 specifications, weld quality, and methods used in correcting welding work.

166

167 1. Assemble and weld built-up sections by methods that maintain true alignment of axes without  
168 exceeding tolerances in AISC 303 for mill material.

169  
170 2.07 SHOP PRIMING

- 171  
172 A. Shop prime steel surfaces except the following:
- 173
  - 174 1. Surfaces embedded in concrete or mortar. Extend priming of partially embedded members to a depth  
175 of 2 inches.
  - 176 2. Surfaces to be field welded.
  - 177 3. Surfaces of high-strength bolted, slip-critical connections.
- 178  
179 C. Priming: Immediately after surface preparation, apply primer according to manufacturer's written  
180 instructions and at rate recommended by SSPC to provide a minimum dry film thickness of 1.5 mils. Use  
181 priming methods that result in full coverage of joints, corners, edges, and exposed surfaces.
- 182
  - 183 4. Stripe paint corners, crevices, bolts, welds, and sharp edges.
  - 184 5. Apply two coats of shop paint to surfaces that are inaccessible after assembly or erection. Change  
185 color of second coat to distinguish it from first.
- 186  
187 D. Painting: Prepare steel and apply a one-coat, nonasphaltic primer complying with SSPC-  
188 PS Guide 7.00, "Painting System Guide 7.00: Guide for Selecting One-Coat Shop Painting Systems," to  
189 provide a dry film thickness of not less than 1.5 mils.

190  
191 2.08 SOURCE QUALITY CONTROL

- 192  
193 A. Bolted Connections: Inspect shop-bolted connections according to RCSC's "Specification for Structural  
194 Joints Using ASTM A 325 or A 490 Bolts."
- 195  
196 B. Welded Connections: Visually inspect shop-welded connections according to AWS D1.1/D1.1M and the  
197 following inspection procedures, at testing agency's option:
- 198  
199 C. In addition to visual inspection, test and inspect shop-welded shear connectors according to requirements  
200 in AWS D1.1/D1.1M for stud welding and as follows:
- 201
  - 202 1. Perform bend tests if visual inspections reveal either a less-than-continuous 360-degree flash or  
203 welding repairs to any shear connector.
  - 204 2. Conduct tests according to requirements in AWS D1.1/D1.1M on additional shear connectors if  
205 weld fracture occurs on shear connectors already tested.
- 206  
207 D. Prepare test and inspection reports.

208  
209 PART 3 - EXECUTION

210  
211 3.01 EXAMINATION

- 212  
213 A. Verify, with certified steel erector present, elevations of concrete- and masonry-bearing surfaces and  
214 locations of anchor rods, bearing plates, and other embedments for compliance with requirements.
- 215
  - 216 1. Prepare a certified survey of existing conditions. Include bearing surfaces, anchor rods, bearing  
217 plates, and other embedments showing dimensions, locations, angles, and elevations.

218  
219 B. Proceed with installation only after unsatisfactory conditions have been corrected.

220  
221 3.02 PREPARATION

222

223 A. Provide temporary shores, guys, braces, and other supports during erection to keep structural steel secure,  
224 plumb, and in alignment against temporary construction loads and loads equal in intensity to design loads.  
225 Remove temporary supports when permanent structural steel, connections, and bracing are in place unless  
226 otherwise indicated.

227  
228 1. Do not remove temporary shoring supporting composite deck construction until cast-in-place  
229 concrete has attained its design compressive strength.

230  
231 3.03 ERECTION

232  
233 A. Set structural steel accurately in locations and to elevations indicated and according to AISC 303 and  
234 AISC 360.

235  
236 1. Set plates for structural members on wedges, shims, or setting nuts as required.  
237 2. Weld plate washers to top of baseplate.  
238 3. Snug-tighten anchor rods after supported members have been positioned and plumbed. Do not  
239 remove wedges or shims but, if protruding, cut off flush with edge of plate before packing with  
240 grout.  
241 4. Promptly pack grout solidly between bearing surfaces and plates so no voids remain. Neatly finish  
242 exposed surfaces; protect grout and allow to cure. Comply with manufacturer's written installation  
243 instructions for shrinkage-resistant grouts.

244  
245 B. Maintain erection tolerances of structural steel within AISC 303, "Code of Standard Practice for Steel  
246 Buildings and Bridges."

247  
248 C. Align and adjust various members that form part of complete frame or structure before permanently  
249 fastening. Before assembly, clean bearing surfaces and other surfaces that are in permanent contact with  
250 members. Perform necessary adjustments to compensate for discrepancies in elevations and alignment.

251  
252 1. Level and plumb individual members of structure.  
253 2. Make allowances for difference between temperature at time of erection and mean temperature when  
254 structure is completed and in service.

255  
256 D. Splice members only where indicated.

257  
258 E. Do not use thermal cutting during erection unless approved by Engineer or Architect. Finish thermally cut  
259 sections within smoothness limits in AWS D1.1.

260  
261 F. Do not enlarge unfair holes in members by burning or using drift pins. Ream holes that must be enlarged  
262 to admit bolts.

263  
264 G. Shear Connectors: Prepare steel surfaces as recommended by manufacturer of shear connectors. Use  
265 automatic end welding of headed-stud shear connectors according to AWS D1.1/D1.1M and manufacturer's  
266 written instructions.

267  
268 3.04 FIELD CONNECTIONS

269  
270 A. High-Strength Bolts: Install high-strength bolts according to RCSC's "Specification for Structural Joints  
271 Using ASTM A 325 or A 490 Bolts" for type of bolt and type of joint specified.

272  
273 1. Joint Type: Snug tightened.

274  
275 B. Weld Connections: Comply with AWS D1.1/D1.1M for tolerances, appearances, welding procedure  
276 specifications, weld quality, and methods used in correcting welding work.

277

278 1. Comply with AISC 303 and AISC 360 for bearing, alignment, adequacy of temporary connections,  
279 and removal of paint on surfaces adjacent to field welds.  
280

281 3.05 FIELD QUALITY CONTROL  
282

283 A. Special Inspections: Engage a qualified special inspector to perform the following special inspections:  
284

- 285 1. Verify structural-steel materials and inspect steel frame joint details.
- 286 2. Verify weld materials and inspect welds.
- 287 3. Verify connection materials and inspect high-strength bolted connections.  
288

289 B. Testing Agency: Engage a qualified testing agency to perform tests and inspections.  
290

291 C. Bolted Connections: Inspect bolted connections according to RCSC's "Specification for Structural Joints  
292 Using ASTM A 325 or A 490 Bolts."  
293

294 D. Welded Connections: Visually inspect field welds according to AWS D1.1/D1.1M.  
295

296 E. In addition to visual inspection, test and inspect field-welded shear connectors according to requirements  
297 in AWS D1.1/D1.1M for stud welding and as follows:  
298

- 299 1. Perform bend tests if visual inspections reveal either a less-than-continuous 360-degree flash or  
300 welding repairs to any shear connector.
- 301 2. Conduct tests according to requirements in AWS D1.1/D1.1M on additional shear connectors if  
302 weld fracture occurs on shear connectors already tested.  
303

304 3.06 REPAIRS AND PROTECTION  
305

306 A. Touchup Painting: Immediately after erection, clean exposed areas where primer is damaged or missing  
307 and paint with the same material as used for shop painting to comply with SSPC-PA 1 for touching up  
308 shop-painted surfaces.  
309

- 310 1. Clean and prepare surfaces by SSPC-SP 2 hand-tool cleaning or SSPC-SP 3 power-tool cleaning.  
311

312 B. Touchup Painting: Cleaning and touchup painting are specified in Section 099113 "Exterior Painting" and  
313 Section 099123 "Interior Painting."  
314

315 C. Touchup Priming: Cleaning and touchup priming are specified in Section 099600 "High-Performance  
316 Coatings."  
317

318 END OF SECTION 05 12 00  
319

SECTION 05 40 00

COLD-FORMED METAL FRAMING

PART 1 - GENERAL

1.1 RELATED DOCUMENTS

- A. Drawings and general provisions of the Contract, including General and Supplementary Conditions and Division 01 Specification Sections, apply to this Section.

1.2 SUMMARY

A. Section Includes:

- 1. Interior Wall framing.
- 2. Ceiling joist framing.

1.3 ACTION SUBMITTALS

- A. Product Data: For each type of cold-formed steel framing product and accessory.

B. Shop Drawings:

- 1. Include layout, spacings, sizes, thicknesses, and types of cold-formed steel framing; fabrication; and fastening and anchorage details, including mechanical fasteners.
- 2. Indicate reinforcing channels, opening framing, supplemental framing, strapping, bracing, bridging, splices, accessories, connection details, and attachment to adjoining work.

- C. Delegated-Design Submittal: For cold-formed steel framing.

1.4 INFORMATIONAL SUBMITTALS

- A. Qualification Data: For testing agency.

1.5 QUALITY ASSURANCE

- A. Testing Agency Qualifications: Qualified according to ASTM E 329 for testing indicated.

- B. Product Tests: Mill certificates or data from a qualified independent testing agency indicating steel sheet complies with requirements, including base-metal thickness, yield strength, tensile strength, total elongation, chemical requirements, and metallic-coating thickness.

1.6 DELIVERY, STORAGE, AND HANDLING

- A. Protect cold-formed steel framing from corrosion, moisture staining, deformation, and other damage during delivery, storage, and handling.

PART 2 - PRODUCTS

2.1 PERFORMANCE REQUIREMENTS

- A. Delegated Design: Engage a qualified professional engineer, as defined in Section 01 40 00 "Quality Requirements," to design cold-formed steel framing.

- 56 B. Structural Performance: Provide cold-formed steel framing capable of withstanding design loads within  
57 limits and under conditions indicated.  
58  
59 1. Design Loads: Per code requirements.  
60 2. Deflection Limits: Design framing systems to withstand design loads without deflections greater  
61 than the following:  
62  
63 a. Interior Load-Bearing Wall Framing: Horizontal deflection of 1/360 of the wall height under  
64 a horizontal load of 5 lbf/sq. ft..  
65 b. Ceiling Joist Framing: Vertical deflection of 1/240 of the span for live loads and 1/240 for  
66 total loads of the span.  
67  
68 3. Design framing systems to provide for movement of framing members located outside the insulated  
69 building envelope without damage or overstressing, sheathing failure, connection failure, undue  
70 strain on fasteners and anchors, or other detrimental effects when subject to a maximum ambient  
71 temperature change of 120 deg F.  
72  
73 C. Cold-Formed Steel Framing Design Standards:  
74  
75 1. Floor and Roof Systems: AISI S210.  
76 2. Wall Studs: AISI S211.  
77 3. Headers: AISI S212.  
78 4. Lateral Design: AISI S213.  
79  
80 D. AISI Specifications and Standards: Unless more stringent requirements are indicated, comply with  
81 AISI S100 and AISI S200.  
82  
83 2.2 COLD-FORMED STEEL FRAMING, GENERAL  
84  
85 A. Steel Sheet: ASTM A 1003/A 1003M, Structural Grade, Type H, metallic coated, of grade and coating  
86 weight as follows:  
87  
88 1. Grade: ST33H.  
89 2. Coating: G60.  
90  
91 2.3 LOAD-BEARING WALL FRAMING  
92  
93 A. Steel Studs: Manufacturer's standard C-shaped steel studs, of web depths indicated, punched, with stiffened  
94 flanges, and as follows:  
95  
96 1. Minimum Base-Metal Thickness: 0.033".  
97 2. Flange Width: 1 3/8".  
98  
99 B. Steel Track: Manufacturer's standard U-shaped steel track, of web depths indicated, unpunched, with  
100 straight flanges, and as follows:  
101  
102 1. Minimum Base-Metal Thickness: 0.033".  
103 2. Flange Width: 1 1/4".  
104  
105 2.4 CEILING JOIST FRAMING  
106  
107 A. Steel Ceiling Joists: Manufacturer's standard C-shaped steel sections, of web depths indicated, punched  
108 with standard holes with stiffened flanges, and as follows:  
109  
110 1. Minimum Base-Metal Thickness: 0.043".  
111 2. Flange Width: 1 3/8"

- 112  
113 2.5 FRAMING ACCESSORIES  
114  
115 A. Fabricate steel-framing accessories from steel sheet, ASTM A 1003/A 1003M, Structural Grade, Type H,  
116 metallic coated, of same grade and coating weight used for framing members.  
117  
118 B. Provide accessories of manufacturer's standard thickness and configuration, unless otherwise indicated, as  
119 follows:  
120  
121 1. Supplementary framing.  
122 2. Bracing, bridging, and solid blocking.  
123 3. Web stiffeners.  
124 4. Anchor clips.  
125 5. End clips.  
126 6. Foundation clips.  
127 7. Gusset plates.  
128 8. Stud kickers and knee braces.  
129 9. Joist hangers and end closures.  
130 10. Hole reinforcing plates.  
131 11. Backer plates.  
132  
133 2.6 ANCHORS, CLIPS, AND FASTENERS  
134  
135 A. Steel Shapes and Clips: ASTM A 36/A 36M, zinc coated by hot-dip process according to  
136 ASTM A 123/A 123M.  
137  
138 B. Power-Actuated Anchors: Fastener system of type suitable for application indicated, fabricated from  
139 corrosion-resistant materials, with allowable load capacities calculated according to ICC-ES AC70, greater  
140 than or equal to the design load, as determined by testing per ASTM E 1190 conducted by a qualified testing  
141 agency.  
142  
143 C. Mechanical Fasteners: ASTM C 1513, corrosion-resistant-coated, self-drilling, self-tapping, steel drill  
144 screws.  
145  
146 1. Head Type: Low-profile head beneath sheathing, manufacturer's standard elsewhere.  
147  
148 D. Welding Electrodes: Comply with AWS standards.  
149  
150 2.7 MISCELLANEOUS MATERIALS  
151  
152 A. Galvanizing Repair Paint: SSPC-Paint 20 or MIL-P-21035B.  
153  
154 B. Shims: Load bearing, high-density multimonomer plastic, and nonleaching; or of cold-formed steel of same  
155 grade and coating as framing members supported by shims.  
156  
157 C. Sealer Gaskets: Closed-cell neoprene foam, 1/4 inch thick, selected from manufacturer's standard widths  
158 to match width of bottom track or rim track members.  
159  
160 2.8 FABRICATION  
161  
162 A. Fabricate cold-formed steel framing and accessories plumb, square, and true to line, and with connections  
163 securely fastened, according to referenced AISI's specifications and standards, manufacturer's written  
164 instructions, and requirements in this Section.  
165  
166 1. Fabricate framing assemblies using jigs or templates.  
167 2. Cut framing members by sawing or shearing; do not torch cut.

- 168  
169  
170  
171  
172  
173  
174  
175  
176  
177  
178  
179  
180  
181  
182  
183  
184  
185  
186  
187  
188  
189  
190  
191  
192  
193  
194  
195  
196  
197  
198  
199  
200  
201  
202  
203  
204  
205  
206  
207  
208  
209  
210  
211  
212  
213  
214  
215  
216  
217  
218  
219  
220  
221  
222
3. Fasten cold-formed steel framing members by welding, screw fastening, clinch fastening, pneumatic pin fastening, or riveting as standard with fabricator. Wire tying of framing members is not permitted.
    - a. Comply with AWS D1.3/D1.3M requirements and procedures for welding, appearance and quality of welds, and methods used in correcting welding work.
    - b. Locate mechanical fasteners and install according to Shop Drawings, with screw penetrating joined members by no fewer than three exposed screw threads.
  4. Fasten other materials to cold-formed steel framing by welding, bolting, pneumatic pin fastening, or screw fastening, according to Shop Drawings.
- B. Reinforce, stiffen, and brace framing assemblies to withstand handling, delivery, and erection stresses. Lift fabricated assemblies to prevent damage or permanent distortion.
- C. Fabrication Tolerances: Fabricate assemblies level, plumb, and true to line to a maximum allowable tolerance variation of 1/8 inch in 10 feet and as follows:
1. Spacing: Space individual framing members no more than plus or minus 1/8 inch from plan location. Cumulative error shall not exceed minimum fastening requirements of sheathing or other finishing materials.
  2. Squareness: Fabricate each cold-formed steel framing assembly to a maximum out-of-square tolerance of 1/8 inch.
- PART 3 - EXECUTION
- 3.1 EXAMINATION
- A. Examine supporting substrates and abutting structural framing for compliance with requirements for installation tolerances and other conditions affecting performance of the Work.
  - B. Proceed with installation only after unsatisfactory conditions have been corrected.
- 3.2 PREPARATION
- 3.3 INSTALLATION, GENERAL
- A. Cold-formed steel framing may be shop or field fabricated for installation, or it may be field assembled.
  - B. Install cold-formed steel framing according to AISI S200 and to manufacturer's written instructions unless more stringent requirements are indicated.
  - C. Install shop- or field-fabricated, cold-formed framing and securely anchor to supporting structure.
    1. Screw, bolt, or weld wall panels at horizontal and vertical junctures to produce flush, even, true-to-line joints with maximum variation in plane and true position between fabricated panels not exceeding 1/16 inch.
  - D. Install cold-formed steel framing and accessories plumb, square, and true to line, and with connections securely fastened.
    1. Cut framing members by sawing or shearing; do not torch cut.
    2. Fasten cold-formed steel framing members by welding, screw fastening, clinch fastening, or riveting. Wire tying of framing members is not permitted.



- 223 a. Comply with AWS D1.3/D1.3M requirements and procedures for welding, appearance and  
 224 quality of welds, and methods used in correcting welding work.  
 225 b. Locate mechanical fasteners and install according to Shop Drawings, and complying with  
 226 requirements for spacing, edge distances, and screw penetration.  
 227  
 228 E. Install framing members in one-piece lengths unless splice connections are indicated for track or tension  
 229 members.  
 230  
 231 F. Install temporary bracing and supports to secure framing and support loads comparable in intensity to those  
 232 for which structure was designed. Maintain braces and supports in place, undisturbed, until entire integrated  
 233 supporting structure has been completed and permanent connections to framing are secured.  
 234  
 235 G. Do not bridge building expansion joints with cold-formed steel framing. Independently frame both sides of  
 236 joints.  
 237  
 238 H. Install insulation, specified in Section 072100 "Thermal Insulation," in built-up exterior framing members,  
 239 such as headers, sills, boxed joists, and multiple studs at openings, that are inaccessible on completion of  
 240 framing work.  
 241  
 242 I. Fasten hole reinforcing plate over web penetrations that exceed size of manufacturer's approved or standard  
 243 punched openings.  
 244  
 245 J. Erection Tolerances: Install cold-formed steel framing level, plumb, and true to line to a maximum  
 246 allowable tolerance variation of 1/8 inch in 10 feet and as follows:  
 247  
 248 1. Space individual framing members no more than plus or minus 1/8 inch from plan location.  
 249 Cumulative error shall not exceed minimum fastening requirements of sheathing or other finishing  
 250 materials.  
 251  
 252 3.4 JOIST INSTALLATION  
 253  
 254 A. Install perimeter joist track sized to match joists. Align and securely anchor or fasten track to supporting  
 255 structure at corners, ends, and spacings indicated on Shop Drawings.  
 256  
 257 B. Install joists bearing on supporting frame, level, straight, and plumb; adjust to final position, brace, and  
 258 reinforce. Fasten joists to both flanges of joist track.  
 259  
 260 1. Install joists over supporting frame with a minimum end bearing of 1-1/2 inches.  
 261 2. Reinforce ends and bearing points of joists with web stiffeners, end clips, joist hangers, steel clip  
 262 angles, or steel-stud sections as indicated on Shop Drawings.  
 263  
 264 C. Space joists not more than 2 inches from abutting walls, and as follows:  
 265  
 266 D. Install joist reinforcement at interior supports with single, short length of joist section located directly over  
 267 interior support, with lapped joists of equal length to joist reinforcement, or as indicated.  
 268  
 269 1. Install web stiffeners to transfer axial loads of walls above.  
 270  
 271 E. Install bridging at intervals indicated. Fasten bridging at each joist intersection as follows:  
 272  
 273 1. Bridging: Joist-track solid blocking of width and thickness indicated, secured to joist webs.  
 274 2. Bridging: Combination of flat, taut, steel sheet straps of width and thickness indicated and joist-  
 275 track solid blocking of width and thickness indicated. Fasten flat straps to bottom flange of joists  
 276 and secure solid blocking to joist webs.  
 277  
 278 F. Secure joists to load-bearing interior walls to prevent lateral movement of bottom flange.

- 279  
280 G. Install miscellaneous joist framing and connections, including web stiffeners, closure pieces, clip angles,  
281 continuous angles, hold-down angles, anchors, and fasteners, to provide a complete and stable joist-framing  
282 assembly.  
283
- 284 3.5 FIELD QUALITY CONTROL  
285
- 286 A. Testing: Owner will engage a qualified independent testing and inspecting agency to perform field tests  
287 and inspections and prepare test reports.  
288
- 289 B. Field and shop welds will be subject to testing and inspecting.  
290
- 291 C. Testing agency will report test results promptly and in writing to Contractor and Architect.  
292
- 293 D. Remove and replace work where test results indicate that it does not comply with specified requirements.  
294
- 295 E. Additional testing and inspecting, at Contractor's expense, will be performed to determine compliance of  
296 replaced or additional work with specified requirements.  
297
- 298 3.6 REPAIRS AND PROTECTION  
299
- 300 A. Galvanizing Repairs: Prepare and repair damaged galvanized coatings on fabricated and installed cold-  
301 formed steel framing with galvanized repair paint according to ASTM A 780 and manufacturer's written  
302 instructions.  
303
- 304 B. Provide final protection and maintain conditions, in a manner acceptable to manufacturer and Installer, that  
305 ensure that cold-formed steel framing is without damage or deterioration at time of Substantial Completion.  
306
- 307 END OF SECTION 054000  
308

## SECTION 05 50 00

### METAL FABRICATIONS

#### PART 1 - GENERAL

##### 1.01 RELATED DOCUMENTS

- A. Conditions of the Contract and portions of Division One of this Project Manual apply to this Section as though repeated herein.

##### 1.02 WORK INCLUDED

- A. Wall supports for Owner Furnished Contractor Installed plate steel signage
- B. Powder coated steel chair rail.

##### 1.03 RELATED WORK

- A. Painting, Section: 09 90 00
- B. Rough Carpentry, Section: 06 60 00

##### 1.04 SUBMITTALS:

- A. Shop Drawings:
  - 1. Shop drawings required for all items. Show all work to be fabricated with all construction details shown in appropriate scale, methods of attachments to other materials, finished dimensions, shop welds and grinding of welds, field assembly joints, etc.
- B. Coordinate work with other suppliers and subcontractors; obtain their approved shop drawing where necessary, or obtain any necessary additional detail information regarding mounting conditions or other aspects of related work.

##### 1.05 QUALITY ASSURANCE:

- C. Take field measurements prior to shop drawing preparation and fabrication.
- D. Comply with the provisions of the following except as otherwise indicated;
  - 1. AWS D1.1 Welding
- E. Qualify welding process and welding operators in accordance with the AWS "Standard Qualification Procedure". Provide certification that welders to be employed in the work have satisfactorily passed AWS qualification tests within the previous twelve months. If recertification of welders is required, retesting will be the Contractor's responsibility.
- F. Preassemble items in shop to greatest extent possible to minimize field splicing and assembly. Disassemble units only as necessary for shipping and handling limitations. Clearly mark units for reassembly and coordinated installation.
- G. Structural Performances
  - A. Capable of withstanding concentrated loads of 200 lbs. applied at any point in any direction or a uniform load of 50 lbs/ft applied horizontally at the top, whichever produces the greatest stress.

1.06 DELIVERY AND STORAGE:

- A. Package, handle, and store at the jobsite in a manner that will avoid damage or deformation. Damaged material will be rejected.

1.07 PROJECT CONDITIONS

- A. Verify dimensions in field for pre-cut or prefabricated items.
- B. Examine job conditions and adjoining construction which may affect the acceptability of the work.

PART 2 - PRODUCTS

2.01 MATERIALS FOR FABRICATIONS:

- A. Powder coated chair rail: Flat rolled steel bar stock 1/8<sup>th</sup> inch thick, 4 inches wide.
- B. Tubing: ASTM A 500 cold formed.
- C. Plates, Shapes, and Bars: ASTM A 36/A 36M.
- D. 3 inch schedule 40 steel pipe and steel plate at partial height walls for stability.
- E. Miscellaneous metals.
- F. Welding Materials: AWS D1.1; type required for materials being welded.
- G. Electrodes for Welding: E70XX, comply with AWS code.
- H. 3 inch schedule 40 steel pipe and steel plate at partial height walls for stability.
- I. ¼" Plate steel.
- J. 1/4 inch diameter x 1 ½ inch threaded steel studs.
  - 1. ASTM A283 Specification for Low and Intermediate Tensile Strength. Carbon Steel Plates; Shapes and Bars.

2.01 FABRICATIONS

- A. Weld permanent connections wherever possible; use continuous welds where exposed and grind smooth; straighten members after welding.
- B. Do shop cutting, drilling, fitting wherever possible. Field measure before fabrication when necessary or required.
- C. Workmanship: Use materials of size and thickness indicated, or if not indicated, as required to produce strength and durability in finished product for use intended. Work to dimensions on shop drawings, using proven details of fabrication and support. Use type of materials indicated or specified for various components of work.

- D. Form exposed work true to line and level with accurate angles and surfaces and straight sharp edges. Ease exposed edges to a radius of approximately 1/32" unless otherwise indicated. Form bent-metal corners to smallest radius possible without causing grain separation or otherwise impairing work
- E. Form exposed connections with hairline joints, flush and smooth, using concealed fasteners wherever possible. Use exposed fasteners of type indicated or, if not indicated, security (countersunk) screws or bolts.
- F. Custom steel brackets: provide all connectors, splices, caps at base, top caps, wall returns, corners, adapters, plugs, anchors bolts, sleeves, etc. for a complete installation. All exposed fasteners to be stainless steel.

## 2.02 ACCESSORIES

- A. Epoxy bolt anchorage: HILTI (HY-10 or equal)
- B. Concrete Inserts: Threaded or wedge type, galvanized ferrous castings, either malleable iron ASTM A 47 or cast steel ASTM A 27. Provide bolts, washers and shims as require, hot-dipped galvanized, ASTM A 153.
- C. Non-shrink Grout: Master Builders "Masterflow 928" or L&M Construction Chemicals "Crystex".
- D. Provide zinc-coated fasteners for exterior use where built into exterior walls or where shown on drawings. Select fasteners for the type, grade and class required.
- E. Provide hot-dipped galvanized coating for fasteners less than 1/2" diameter that are in contact with pressure-treated wood.
- F. Bolts and Nuts: Regular hex head type, ASTM A 307, Grade A or Type 304 stainless steel, ASTM A 320. High Strength bolts and nuts, ASTM A 325.
- G. Lag Bolts: Square head type, FS FF-B-561.
- H. Machine Screws: Cadmium plated steel, FS FF-S-92, Security Screws.
- I. Wood Screws: Flat head carbon steel, FS FF-S-111.
- J. Plain Washers: Round, carbon steel, FS FF-W-92.
- K. Concrete Anchorage Devices: Wedge-type expansion bolts, FS FF-S-325, Group II, Type 4, Class 1, zinc coated or stainless steel as shown on the drawings and installed in accordance with manufacturer's recommendations.
  1. Kwik-bolt", Hilti Corporation
  2. "Wej-it", Wej-it Corporation.
- L. Masonry: Sleeve anchors zinc coated or stainless as shown on the drawings.
  1. Rawl Lok/Bolt.
  2. HILTI - Sleeve anchor.
- M. Toggle Bolts: Spring-wing type, FS FF-B-558, Type I, Class I and Style 1 zinc coated or stainless steel as shown on the drawings.
- N. Lock Washers: Helical spring type carbon steel, FS FF-W-84.

## 2.03 STEEL FINISHES

- A. Preparation for Shop Painting: Clean steel items free of mill scale, rust and foreign matter, grease, oil, dust, and dirt in accordance with SSPC SP-2, SP-3, or SP-7.
- B. Shop Priming: Apply one shop coat of metal primer using manufacturer's standard primer, except stainless steel, galvanized steel, and other non-ferrous items.
- C. Powder-coat where noted.
  - 1. Provide polyester, powder-coat finish of completed fabrication.
  - 2. Manufacturer: Tiger Drylac or equal.
  - 3. Color: Selected by Architect from manufacturer's standard, RAL colors.
  - 4. Texture/sheen: Smooth texture, sheen to be determined from manufacturer's full range.

#### 2.04 STEEL BRACKETS

- A. Fabricated to true lines, joints welded and ground smooth.

### PART 2 - EXECUTION

#### 3.01 INSTALLATION

- A. Anchor powder coated flat stock to plaster wall by drilling holes for 1/4 inch studs and anchoring with epoxy.
- B. Anchorage to masonry with expansion bolts, sleeves, toggle bolts or approved similar. Do not use wood plugs for anchorage.
- C. Bolts, screws, and similar fastenings for field connections shall be of the same material and finish as the parts being fastened.
- D. Immediately following installation, touch up any minor flaws, scratches, or defects with matching texture and paint. Replace any materials damaged beyond an acceptable touch-up.
- E. Immediately after erection, repaint field connections, weld burns, abraded surfaces. Scrape and wire brush loose and scaling paint to sound metal, follow with spot priming.
- F. Install manufactured units and specialty products in accordance with the manufacturer's instructions and approved shop drawings.
- G. Do not proceed with installation until conditions are satisfactory.
- H. Install in accordance with approved shop drawings.

#### 3.02 ADJUSTING AND CLEANING

- A. Touchup Painting: Immediately after erection, clean field welds, bolted connections, and abraded areas. Paint uncoated and abraded areas with the same material as used for shop painting to comply with SSPC-PA 1 for touching up shop-painted surfaces.
  - 1. Apply by brush or spray to provide a minimum 2.0-mil dry film thickness.

END OF SECTION 05 50 00

SECTION 06 10 00

ROUGH CARPENTRY

PART 1 - GENERAL

1.01 RELATED DOCUMENTS

- A. Conditions of the Contract and portions of Division One of this Project Manual apply to this Section as though repeated herein.

1.02 SCOPE

- A. Perform all Work required to complete the Rough Carpentry indicated by the Construction Documents, and furnish all items necessary for its proper installation.

1.03 RELATED WORK

- A. Unit Masonry, Section 04 20 00.
- B. Metal Fabrications, Section 05 50 00.
- C. Plastic Laminate Casework, Section 06 41 16.
- D. Solid Surface, Section 06 61 18.

1.04 SUBMITTALS

- A. Submit in accordance to the General Conditions of the contract.
- B. Material certificates for dimensional lumber specified to comply with minimum allowable unit stresses indicated on the documents. Indicate species and grade selected for each use, and design values approved by American Lumber Standards Committee.
- C. Framing plan indicating field verified dimensions, structural performances, ratings, compliance with resilient flooring manufacturers' substrate requirements and shop fabricated architectural woodwork requirements for Owner and A/E approval and coordination of Owner provided electrical.
- D. Schedule for completion of rough framing for coordination of templating for shop fabrication of architectural woodwork.
- E. Wood treatment data as follows, including chemical treatment manufacturer's warranty and instructions for handling, storing, installing, and finishing treated materials:
  - 1. For each type of preservative-treated wood product, include certification by treating plant stating type of preservative solution and pressure process used, net amount of preservative retained, and compliance with applicable standard.

1.05 REFERENCES

- A. American Institute of Timber (AITC)
  - 1. AITC, Timber Construction Manual
- B. American Forest and Paper Association (AFPA)
  - 1. AFPA, National Design Specification for Wood Construction.
  - 2. AFPA, Design Values for Wood Construction, NDS Supplement.

- 1 C. American Plywood Association (APA)
- 2 1. APA, Plywood Design Specification.
- 3
- 4 D. American National Standards Institute (ANSI)
- 5 1. ANSI A190.1, Structural Glued Laminated Wood.
- 6 2. ANSI A208.1, Material Formed Wood Particle Board.
- 7
- 8 E. American Society for Testing and Materials (ASTM)
- 9 1. ASTM E84, Test for Surface Burning Characteristics of Building Materials.
- 10
- 11 F. American Wood Preservers Association (AWPA)
- 12 1. AWPA C-20, Structural Lumber - Fire Retardant Treatment by Pressure Processes.
- 13
- 14 G. American Wood Preservers Bureau (AWPB)
- 15 1. AWPB LP-2, Pressure Treatment with Water-Borne Preservatives.
- 16
- 17 H. National Bureau of Standards (NBS)
- 18 1. NBS PS 1, Voluntary Product Standard for Construction and Industrial Plywood.
- 19 2. NBS PS 20, Voluntary Product Standard for Lumber.
- 20

#### 21 1.06 DELIVERY, STORAGE AND HANDLING

- 22
- 23 A. Deliver materials to the site dry and store above ground on level wood blocking, cover from
- 24 rain, allowing drainage of water from all parts. Handle with care to avoid damage.
- 25

#### 26 1.07 COORDINATION

- 27
- 28 A. Correlate location of all framing, furring, blocking, grounds and similar items with all trades
- 29 including electrical by Owner.
- 30
- 31 B. Verify all dimensions and shop drawing requirements prior to proceeding with work.
- 32
- 33 C. Avoid delay of work of other trades dependent on or affected by carpentry work.
- 34

#### 35 1.08 ENVIRONMENTAL REQUIREMENTS

- 36
- 37 A. Low-Emitting Materials, Adhesives, and Sealants: Materials used on the interior of the
- 38 building (defined as inside the weatherproofing system and applied on site) must not exceed
- 39 the following requirements.
- 40 1. Adhesives, Sealants and Sealant Primers: South Coast Air Quality Management
- 41 (SCAQMD) Rule # 1168, requirements in effect on July 1, 2005, and rule amendment
- 42 date January 7, 2005.
- 43 2. Aerosol Adhesives: Green Seal Standard for Commercial Adhesives GS-36,
- 44 requirements in effect on October 19, 2000.
- 45
- 46 B. Low- Emitting Materials, Composite Wood & Agrifiber Products: Composite wood and
- 47 agrifiber products used inside the weatherproofing system shall contain no added urea-
- 48 formaldehyde resins.
- 49 1. Laminating Adhesives used to fabricate on-site and shop applied composite wood and
- 50 agrifiber assemblies shall contain no added urea-formaldehyde resins.
- 51

### 52 PART 2 - PRODUCTS

#### 53 2.01 MATERIALS



- 1 A. Wood for nailers, blocking, furring, sleepers and other miscellaneous boards: Construction  
2 grade, S4S, dried, 19 percent maximum moisture content. Pressure preservative treat items in  
3 contact with flashing, waterproofing, masonry, concrete or the ground.  
4
- 5 B. Plywood sheathing shall be 5/8 inch thick, 5-ply, CDX APA Rated, un-sanded with a  
6 minimum 24/0 span rating. Sheathing shall be by 48 inches wide by 96 inches long.  
7
- 8 C. Fire-retardant treated wood products shall be pressure-impregnate wood materials to comply  
9 with ASTM E84, Class A and with AWWA C-20 and C-27. Each piece shall bear UL label  
10 "FR-S" for 25 maximum flame spread. Moisture content after treatment shall be 19 percent  
11 for lumber and 15 percent for plywood.  
12 1. Treated materials shall be "Dricon" as manufactured by Koppers Company, Inc.  
13
- 14 D. Rough hardware shall include all nails, spikes, screws, bolts and similar items of types and  
15 sizes sufficient to draw and rigidly secure members for which they are used. Fasteners shall  
16 be galvanized plated at exterior locations and at all treated wood applications.  
17
- 18 E. Adhesive shall be of proper design and characteristics to rigidly secure materials for which  
19 they are used. Adhesive shall be "Titebond VOC-Compliant Heavy Duty Construction  
20 Adhesive" conforming with ASTM C557, as manufactured by Franklin International; or  
21 approved equal.  
22 1. Provide construction adhesive with a VOC content of less than 70 g/l.  
23

## 24 PART 3 - EXECUTION

### 25 3.01 PREPARATION

- 26 A. Examine all adjoining work, verify all governing dimensions, and report any unsatisfactory  
27 conditions.  
28
- 29 B. Provide temporary enclosures, partitions, or stairs to properly protect and facilitate the work.  
30  
31  
32

### 33 3.02 GENERAL INSTALLATION

- 34 A. Install materials and systems in accordance with manufacturer's published instructions and  
35 requirements. Install materials with uniform appearance and in proper relation with adjacent  
36 construction.  
37  
38
- 39 B. Cut and frame all lumber into the respective locations, true to line, grade, plumb and level.  
40 Form nailers, blockings and bucks to the shape and dimension indicated. Cut and frame all  
41 rough carpentry work required by the other sections.  
42
- 43 C. Use only sound, thoroughly seasoned materials of longest practical lengths and sizes to  
44 minimize jointing. Use materials free from warp which cannot be easily corrected by  
45 anchoring and attachment.  
46
- 47 D. Treat all wood nailers, sleepers, blocking, furring, other wood in contact with concrete,  
48 masonry adjacent to grade or exterior which shall be inaccessible in finished work.  
49
- 50 E. Provide blocking, bucks and framing for all trades as required.  
51
- 52 1. Blocking to be provided at the following locations:  
53 a. All wall hung casework, shelving, cabinetry, countertop.  
54 b. All wall hung/mounted equipment including monitors.  
55 c. And as indicated on drawings.

- 1  
2 F. Include 2 inch nominal blocking in metal stud partitions required for backing of all  
3 accessories, cabinetry, and other surface or recessed items, including Audio/Visual.  
4  
5 G. Where finish trim is applied directly to framing members or blocking, such members shall be  
6 perfectly straight, clear and well seasoned. Warp or other poor characteristics not allowed.  
7  
8 H. Provide solid surfaces at least 1 1/2 inches wide in both directions at all corners for securing  
9 finishes.  
10

11  
12 3.03 HARDWARE

- 13  
14 A. Secure permanently and in proper position all materials with the necessary fastenings to  
15 provide the strength and rigidity required to complete the work. Provide washers under bolt  
16 heads and nuts in contact with wood.  
17  
18 B. Bolt nailers and blocking to steel, masonry or concrete members with bolts of proportionate  
19 strength of members attached, length required, spaced 2 feet 0 inches on center and 4 inches  
20 from each end, except as otherwise indicated. Unless otherwise indicated, anchor bolts shall  
21 be 3/8 inch diameter by length required or comparable power actuated fasteners.  
22  
23 C. Nail plywood in accord with APA recommendations.  
24

25 3.04 WALL SHEATHING

- 26  
27 A. Place sheathing with all joints over supports. Provide 1 1/2 inch framing at all joints not over  
28 supports where blocked joints are noted on Drawings.  
29  
30 B. Stagger end joints so that joint between adjacent panels occurs over different supports. Allow  
31 1/8 inch spacing between panels on all sides.  
32  
33 C. Fasten with 8d ring-shank nails at 6 inch on center at all edges and 12 inch on center at all  
34 intermediate supports, unless noted otherwise. Sheathing may be stapled with 1 1/2 inch long  
35 15 gauge staples at 4 inch on center at all edges and 12 inch on center at all intermediate  
36 supports, unless noted otherwise.  
37  
38 D. Install in accord with recommendations of APA.  
39

40 3.05 TEMPORARY ENCLOSURES

- 41  
42 A. The contractor shall furnish, erect, keep in good repair and remove all temporary enclosures.  
43 Protect the existing garden from damage with a plywood enclosure to avoid prevent walking  
44 on the garden. Remove plywood enclosure after completion of work and restore garden where  
45 damaged by work.  
46

47 3.06 CLEANING

- 48  
49 A. Remove from the site all debris resulting from the Work of this Section.  
50  
51

END OF SECTION 06 10 00

## SECTION 06 41 16

### PLASTIC LAMINATE CLAD CASEWORK

#### PART 1 - GENERAL

##### 1.01 RELATED DOCUMENTS

- A. Conditions of the Contract and portions of Division One of this Project Manual apply to this Section as though repeated herein.

##### 1.02 WORK INCLUDED

- A. Base, Wall and Custom Storage Cabinets and associated Partitions and Shelving.
- B. Hardware.

##### 1.03 RELATED WORK

- A. Rough Carpentry: Section 06 10 00.
- B. Joint Sealers: Section 07 92 00.
- C. Solid Surface: Section 06 61 18.
- D. Plumbing (Sinks, pipe, fittings, final connections, etc.): Division 22.

##### 1.04 REFERENCES

- A. Plastic Laminate: National Electrical Manufacturers Association (NEMA) Publication No. LD3-1991.
- B. Fiberboard Core: ANSI A208.2.

##### 1.05 SUBMITTALS

- A. Submit in accordance with the General Conditions of the Contract.
  - 1. Product Data: Manufacturer's catalog information edited to indicate specific products and related accessories to be provided for this Project.
  - 2. Shop Drawings: Show layout of casework, typical details of construction, and finish selections.
    - a. Locate rough-in for services required and show methods of compensating for minor variations in actual job conditions within specified tolerances.
    - b. Include details of fastening to all other work, countertop layout for each location, details of countertop construction including backsplash, endsplash, and edge details, plastic laminate selections previously made by Architect/Engineer and type of core substrate material.
    - c. Field measure for all countertops.
    - d. Indicate all hardware and keying schedule.

##### 1.06 QUALITY ASSURANCE

- A. Quality Standards: Perform work in accordance with Architectural Woodwork Quality Standards (current edition), Guide Specification and Quality Control Program as set forth by the Architectural Woodwork Institute (AWI).

- B. ANSI/BHMA A156.9 – Cabinet Hardware.

#### 1.07 DELIVERY, STORAGE AND HANDLING

- A. Deliver casework items only when proper storage conditions will be available. Store casework in protected area until ready for installation.
- B. Maintain optimum humidity and temperature conditions after receipt of materials.
- C. Store in manner to allow free circulation of air around all items.
- D. Maintain temperature of casework storage areas between 50 to 75 degrees Fahrenheit.

#### PART 2 - PRODUCTS

##### 2.01 CASEWORK

- A. AWI Section 400, Custom grade.

##### 2.02 MANUFACTURERS

- A. The following casework manufacturers are acceptable as long as they meet or exceed this specification.
  1. A.J. Pietsch Company, (414) 342-0531.
  2. Carley Wood Associates, Inc. (608) 249-7444.
  3. Central Wisconsin Woodworking, (715) 675-4491.
  4. Creative Laminates, Inc., (800) 441-5885.
  5. Diversified Woodcrafts Inc., (920) 842-2136.
  6. Glenn Rieder, Inc., (414) 449-2888.
  7. Hillcraft Ltd., (608) 221-3220.
  8. Lange Brothers Woodwork Co, Inc., (414) 466-2226.
  9. Stück Wood Works Inc., (414) 351-5595.
  10. T. J. Hale Company, (262) 255-5555.
  11. Techline, (608) 238-6868.
  12. Wood Design Inc., (920) 563-4833.
  13. Woodmill Products, Inc., (262) 754-4641.
  14. Or approved equal.
- B. Hardware manufacturers.
  1. Doug Mockett & Co. (800) 523-1269.
  2. A&M Hardware (888) 647-0200
  3. Or approved equal.

##### 2.03 BASE AND CUSTOM STORAGE CABINETS

- A. Bottoms, Sides and Sub-top: 3/4-inch 45-47 pound density particle board.
  1. Finish where not exposed: 8 to 11 mil melamine resin overlay.
- B. Back Panel: 3/8-inch 45-47 pound density particle board.
  1. Finish: 8 to 11 mil melamine resin overlay to match cabinet interior.
  2. Non-Exposed Side Finish: 8 to 11 mil melamine resin overlay to match.
  3. If back exposed, provide 3/4-inch material, finished to match.
- C. Top of Base, Custom Storage Cabinet: Full framed wood. Provide full sub-top and 6 inch spreaders between all drawers and door/drawer.

- D. Back panels rabbeted into sides top and bottom. Secure with hot melt glue or glue and mechanical fasteners.
- E. Provide finished end panels at all exposed end locations. Ends adjacent to appliances shall be considered as exposed ends.

#### 2.04 DOOR/DRAWER CONSTRUCTION AND EDGING

- A. Door/Drawer Fronts: 3/4-inch thick core.
- B. Exposed Edges, Endsplashes:
  - 1. Finished to match exposed face.
- C. Laminate face/balancer to core with PVA rigid adhesives, under pressure, nor natural setting process. Heat process or contact adhesive not allowed.
- D. Door/Drawer/Cabinet Body Edges: 1 mm PVC thru-color, acid resistant hot melt applied.

#### 2.05 PLASTIC LAMINATE SURFACING

- A. Manufacturers: Wilsonart , Arpa, Formica, Lamin-Art, Nevamar, or approved equal.
- B. Exposed Exterior Surfaces (except countertops): NEMA GP28, 0.028 inch thick, standard vertical grade.
- C. Interior Surfaces/Backing Sheets: NEMA CL20, 0.020 inch thick, standard cabinet liner grade if applicable.
- D. Colors:
  - 1. Horizontal Surface Plastic Laminate color to be selected from manufacturer's full range.
  - 2. Vertical Surface Plastic Laminate color to be selected from manufacturer's full range.
- E. Contrasting text where indicated on drawings.

#### 2.06 DRAWERS

- A. Backs, Sides, Fronts: 1/2-inch thick, medium density fiberboard with melamine overlay.
- B. Dovetail/dado fronts and backs, secure with glue.
- C. Bottoms: 3/8-inch thick.
- D. Rabbet bottoms into sides, front and back; staple and glue.
- E. Drawer fronts screwed on from drawer inside.
- F. Reinforcement: 1/2 inch thick under-bottom stiffeners, one at 24 inch drawers, two at 36 inch drawers, four at 48 inch drawers.

#### 2.07 SHELVES

- A. Shelves under 27 inches long: 3/4-inch thick 45-47 pound density particle board.

- B. Shelves over 27 inches long: 1 inch thick 45-47 pound density particle board. Provide additional bracket supports at long space shelving.
- C. Finish: Finished to match faces.
- D. Edging: Material to match the shelf.

#### 2.08 BASES

- A. Two, continuous, 4 inch high by 1-1/2 inch thick lumber, or 4 inch high by 3/4 inch exterior grade plywood, 2 foot on center. See drawings for base dimension.
- B. Provide two positioning strips to cabinet bottom for concealed fastening.

#### 2.09 HARDWARE

- A. Pulls:
  - 1. Doug Mockett & Company DP211B – Straight Edge Drawer Pull Medium
- B. Self-Closing Hinges: Blum Model 71.6530 with 175L8100 base plate.
- C. Drawer Slides: Accuride or approved equal.
- D. Locks:
  - 1. Cabinet Locks: Keyed to match, five pin. All casework to be lockable. Key casework alike per area.
- E. Steel Brackets
  - a. Refer to Solid Surface Specification 06 61 18.

Hardware finish: 626 (US26D) Brushed Chrome or Brushed Satin Aluminum.

#### 2.010 WORKMANSHIP

- A. Cabinet parts shall be accurately machined utilizing hardwood dowels for premium quality grade joinery construction. Glue and mechanically fasten all joints for maximum rigidity.
- B. All cases shall be square, plumb, true and self-supporting.
- C. Provide removable back panels and closure panels for plumbing access where shown on Project Drawings.

### PART 3 - EXECUTION

#### 3.01 DELIVERY

- A. Store and install in a ventilated building not exposed to extreme temperature and/or humidity.

#### 3.02 INSTALLATION

- A. Installation shall be by the manufacturer's authorized representatives using factory trained personnel experienced in the installation of this type of equipment.
- B. Uncrate, set up, place, level, scribe and anchor all cabinets according to manufacturer's recommendations.

- C. Remove and replace tops, backs, panels, shelves and other items necessary to allow other Sections to complete their work of connecting services.
- D. Do all cutting, boring, patching required for the installation of work of other Sections.
- E. Provide all necessary fillers, panels, end panels, scribes required to make complete installation as detailed.
- F. Where casework meets wall surfaces, set with uniform space not to exceed 1/8-inch. Seal all joints with silicone sealant to a slightly concave joint, using backer rod where required. Apply sealant in accord with Section 07 92 00.
- G. Cabinets with surfaces having machine or tool marks will be rejected.
- H. All finishes must be smooth, uniform in color and match approved sample.
- I. Prior to final inspection, examine installation of the work of this Section. Repair or replace all defects found. Leave installation clean, undamaged and ready for use.

3.02 FINISH SCHEDULE

PLam Vertical Surfaces Formica Terril 2297-58 Matte Finish or approved equal selected by architect.

END OF SECTION 06 41 16

Page Intentionally Left Blank



SECTION 06 61 18

SOLID SURFACE

PART 1 - GENERAL

1.01 RELATED DOCUMENTS

- A. Conditions of the Contract and portions of Division One of this Project Manual apply to this Section as though repeated herein.

1.02 WORK INCLUDED

- A. Solid surface countertops, sills, shelves.
- B. Concealed painted steel mounting brackets.

1.03 RELATED WORK

- A. Plastic Laminate Casework 06 41 16.
- B. Gypsum Wall Board Section 09 29 00.

1.04 SUBMITTALS

- A. Submit in accord with the General Conditions of the Contract.
  - 1. Product Data: Manufacturer's catalog information edited to indicate products to be provided for this Project.
    - a. Joint adhesives or mastics, color matched.
    - b. Joint sealants.
    - c. Fastening adhesive
  - 2. Samples:
    - a. Product Data.
    - b. Solid surface sheet material.
    - c. Include color chart showing full range of available colors for sheet

1.05 QUALITY ASSURANCE

- A. Fabricator/Installer Qualifications: Minimum three years experience in fabrication and installation of solid surface materials or certification by Distributor.
  - 1. Qualifications: Proof of fabricator qualifications.
  - 2. Certificates: Copies of ISO certifications.
  - 3. Test Reports:
    - a. Flammability test reports.
    - b. Food preparation zone use test reports.
  - 4. Manufacturer's Fabrication and Installation Manual.
  - 5. Manufacturer's Fabrication and Installation Check List.
- B. Shop Drawings: Provide plans, sections, and large-scale details. Include attachment provisions and fabrication methods.

1.06 WARRANTY

- A. Provide manufacturer's standard 10 year warranty against defects in workmanship.

1  
2 1.07 MAINTENANCE  
3

- 4 A. Extra Materials: Provide for future repair use by Owner.  
5 1. Minimum 4 sf per 50 lf of each countertop color.  
6

7 1.08 SPECIAL INSTRUCTIONS  
8

- 9 A. Do not deliver components to project site until spaces are ready for installation.  
10

11 1.09 ENVIRONMENTAL CONDITIONS  
12

- 13 A. Installation spaces must be maintained at normal occupancy temperature and humidity levels for  
14 minimum 72 hours prior to and continuously following installation.  
15

16 1.010 ENVIRONMENTAL REQUIREMENTS  
17

- 18 A. Recycled content: Provide products manufactured from recycled content as specified, to be measured  
19 and documented according to the LEED Green Building Rating System.  
20

- 21 1. Solid surface: Minimum 50% post-consumer recycled content.  
22

- 23 B. Low-Emitting Materials, Field applied Paints and Coatings: Interior paints and coatings applied on-  
24 site must meet the limitations and restrictions concerning chemical components set by the following  
25 standards:  
26

- 27 1. "All Other Architectural Coatings, Primers and Undercoats: South Coast Air Quality  
28 Management District (SCAQMD) Rule #1113, Architectural Coatings", rules in effect on  
29 January 1, 2004.  
30

- 31 C. Low-Emitting Materials, Adhesives, and Sealants: Materials used on the interior of the building  
32 (defined as inside the weatherproofing system and applied on site) must not exceed the following  
33 requirements.  
34

- 35 1. Adhesives, Sealants and Sealant Primers: South Coast Air Quality Management (SCAQMD)  
36 Rule # 1168, requirements in effect on July 1, 2005, and rule amendment date January 7,  
37 2005.  
38 2. Aerosol Adhesives: Green Seal Standard for Commercial Adhesives GS-36, requirements in  
39 effect on October 19, 2000.  
40

41 PART 2 - PRODUCTS  
42

43 2.01 MATERIALS  
44

- 45 A. Solid Surface  
46

- 47 1. Solid Surface  
48 a. Formica Solid Surfacing  
49 b. Or approved equal by: Dupont, Corian; Wilsonart, Solid Surfacing.  
50

- 51 B. No cracked, chipped, broken, stained, or defective material will be accepted.  
52

- 53 1. Materials fabricated to thickness and size shown on drawings.  
54 a. All sizes to be field verified.  
55

- 56 C. Color Match Differences: Minimal.  
57

- 58 D. Adhesives: Use manufacturer's recommended adhesives, and installation instructions. See product  
59 fabrication manuals for application techniques and surface preparation.  
60

1 E. Provide painted steel concealed brackets at solid surface shelf A&M Hardware, Inc. 12” float shelf  
2 and hidden shelf brackets or approved equal.  
3

4 F. Provide painted steel concealed brackets at solid surface countertop overhang A&M concealed  
5 counter bracket with a 1/2” support arm. Provide depth per countertop overhand depth indicated on  
6 drawings.  
7

8 2.02 FABRICATION  
9

10 A. Field verify measurements.

11  
12 B. Finished Surfaces: Uniform as chosen by A/E from full range with all edge profiles as shown on  
13 drawings. Square edge.  
14

15 C. Color and finish:

- 16  
17 1. Solid Surface 1: To be selected by Architect from full range of colors and finishes.  
18 2. Solid Surface 2: To be selected by Architect from full range of colors and finishes.  
19 3. Solid Surface 3: To be selected by Architect from full range of colors and finishes.  
20

21 Color selection may include selections from both Corian and Formica colors including but not  
22 limited to Lava Rock, Luna Sand.  
23

24 PART 3 - EXECUTION  
25

26 3.01 EXAMINATION  
27

28 A. Examine cabinets upon which countertops will be installed. Coordinate with cabinet specification  
29 section to assure that cabinets are set to the following tolerance or better.

- 30 1. Verify that cabinets are level to 1/8 in. in 10 ft .  
31 2. Review manufacturer’s Fabrication and Installation Check List.  
32

33 B. Examine walls upon which sill will be installed.

- 34 1. Verify wall is flat and acceptable for base application.  
35 2. Review manufacturer’s Fabrication and Installation Check List.  
36

37 C. Coordinate with responsible entity to correct unsatisfactory conditions.

38  
39 D. Commencement of work by installer is acceptance of conditions.  
40

41 3.02 INSTALLATION  
42

43 A. Install fabricated items according to material manufacturers printed instructions.

44  
45 B. Set all items square and true with edges of face joints smooth, even, neat and tight against other  
46 materials.  
47

48 3.03 PROTECTION, REPAIRING AND CLEANING  
49

50 A. Replace damaged and defective work.

51  
52 B. Clean according to manufacturer's directions. Use no acids or harsh abrasives.  
53  
54  
55

END OF SECTION 06 61 18

Page Intentionally Left Blank

SECTION 07 14 00

LIQUID-APPLIED WATERPROOFING

PART 1: GENERAL

1.01 RELATED DOCUMENTS

- A. Applicable provisions of Division 1 shall govern all work under this section.

1.02 WORK INCLUDED

- A. Liquid-applied elastomeric rubber air/vapor/water barrier (liquid-applied water resistive barrier).

1.03 SUBMITTALS

- A. Submit in accord with the General Conditions of the contract.
  - 1. Manufacturer's literature and recommendations for application.

1.04 REFERENCES

- A. American Society for Testing and Materials (ASTM)
  - 1. ASTM E 96: Water vapor permeance
  - 2. ASTM E 514-90: Water penetration and leakage through masonry
  - 3. ASTM D 5385: Hydrostatic pressure resistance of waterproofing membranes
  - 4. ASTM C 836: Low-temperature flexibility and crack bridging
  - 5. ASTM D 412: Tensile strength
  - 6. ASTM D 4541: Adhesion to substrate

1.05 QUALITY ASSURANCE

- A. Applicator: Certified in writing by the manufacturer as a licensed or approved applicator.

1.06 DELIVERY, STORAGE AND HANDLING

- A. Deliver materials to job site in manufacturer's original sealed containers with manufacturer's name and brand name legible and intact.
- B. Protect materials before, during and after installation and store per manufacturer's guidelines.
- C. In the event of damage, immediately make replacements to the approval of the Construction Manager, at no additional cost to the Owner.

1.07 WARRANTY

- A. Manufacturer's Warranty: Five (5) years commencing on date of Substantial Completion.

PART 2: PRODUCTS

2.01 MANUFACTURER

- A. Manufacturer: Protective Coatings Technology, Inc. Menomonie, Wisconsin 54751, (800) 846-3020.

2.02 COMPONENTS

- A. Poly-Wall AIRLOC FLEX cold liquid-applied elastomeric rubber air/vapor/water barrier.
- B. Approved equal product by W. R. Grace and Company, Advanced Coatings, Inc. or approved equal.

PART 3: EXECUTION

1 3.01 EXAMINATION

2

- 3 A. Examine surfaces to receive the air/vapor/water barrier prior to installation. Applicator or representative of the  
4 manufacturer shall inspect entire area the air/vapor/water barrier is to be applied. Surface defects or improper  
5 conditions that would affect installation shall be brought to the attention of the Construction Manager in writing  
6 for correction before commencing installation.

7

8 3.02 PREPARATION

9

- 10 A. Remove loose or foreign matter, which might impair adhesion of materials.  
11 B. Filling any voids with compatible caulk and/or filler.  
12 C. Substrates must be dry and free of frost.

13

14 3.03 INSTALLATION

15

16 A. General

- 17 1. Install in accordance with manufacturer's instructions, recommendations, and specific project application  
18 instructions.  
19 2. Apply at a minimum thickness of 50 wet mils of product.

20

21

22

END OF SECTION 07 14 00

23

SECTION 07 21 00

BUILDING INSULATION

PART 1 - GENERAL

1.01 RELATED DOCUMENTS

- A. Conditions of the Contract and portions of Division One of this Project Manual apply to this Section as though repeated herein.

1.02 WORK INCLUDED

- A. Insulation.
- B. Vapor Retarder.

1.03 SUBMITTALS

- A. General: Submit each item in this article according to the Conditions of the Contract and Division 1 Specification Sections.
  - 1. Manufacturer's Data: Submit manufacturer's data for each type of insulation required. Include data substantiating that the materials comply with specified requirements, including GreenGuard Certification.

1.04 DELIVERY, STORAGE AND HANDLING

- A. Deliver material to the site in unopened packages, with identification labels intact.
- B. Protect insulations from physical damage and from becoming wet, soiled, or covered with ice or snow. Comply with manufacturer's recommendations for handling, storage and protection during installation.
- C. Protect plastic insulation against ignition at all times.
- D. Remove damaged materials from site.

1.05 ENVIRONMENTAL REQUIREMENTS

- A. Low-Emitting Materials, Adhesives, and Sealants: Materials used on the interior of the building (defined as inside the weatherproofing system and applied on site) must not exceed the following requirements.
  - 1. Adhesives, Sealants and Sealant Primers: South Coast Air Quality Management (SCAQMD) Rule # 1168, requirements in effect on July 1, 2005, and rule amendment date January 7, 2005.
  - 2. Aerosol Adhesives: Green Seal Standard for Commercial Adhesives GS-36, requirements in effect on October 19, 2000.

PART 2 - PRODUCTS

2.01 INSULATION TYPE 5: FURRED-WALL RIGID INSULATION (GYPSUM BOARD PROTECTED AREAS).

- A. Board: Expanded polystyrene, (R5.5/inch) ASTM C578-87a, Type II.
- B. Furring: Metal Studs/Resilient Furring Channels.

1  
2 2.02 SPRAYED POLYURETHANE FOAM SEALANT  
3

- 4 A. Single-component polyurethane foam sealant for sealing cracks, gaps around openings and joints  
5 between other materials so as prevent air infiltration and water penetration. Provide products that  
6 have a VOC content of less than 250 g/l.  
7

8 1. Manufacturers:

- 9 a. OSI, Green Series, "Pro Foam II Minimally Expanding Sealant".  
10 b. Dow, "Great Stuff Gaps and Cracks."  
11 c. Soy Seal for Gaps & Cracks.  
12 d. Or approved equal.  
13

14 PART 3 - EXECUTION  
15

16 3.01 EXAMINATION  
17

- 18 A. Examine substrates and conditions under which insulation work is to be performed. Do not proceed  
19 with insulation work until unsatisfactory conditions have been corrected.  
20

21 3.02 PREPARATION  
22

- 23 A. Clean substrates of substances harmful to insulations or vapor barriers, including removal of  
24 projections, which might puncture vapor barriers.  
25

26 3.03 INSTALLATION  
27

28 A. General

- 29 1. Comply with manufacturer's instructions for particular conditions of installation in each  
30 case. If printed instructions are not available or do not apply to project conditions,  
31 consult manufacturer's technical representative for specific recommendations before  
32 proceeding.  
33 2. Extend insulation full thickness as shown over entire area to be insulated. Cut and fit  
34 tightly around obstructions, and fill voids with insulation. Remove projections which  
35 interfere with placement.  
36 3. Apply a single layer of insulation to required thickness, unless otherwise shown or  
37 required to make up total thickness.  
38 4. Supply and install manufacturer recommended construction tape over all joints in rigid  
39 insulation per manufacturer's instructions.  
40

- 41 B. Miscellaneous Voids: Install insulation in miscellaneous voids and cavity spaces where required to  
42 prevent gaps in insulation using the following materials:

- 43 1. Spray Polyurethane Foam Sealant: Apply according to manufacturer's written instructions.  
44

45 3.04 INSTALLATION OF VAPOR RETARDERS  
46

- 47 A. General: Extend vapor retarder to extremities of areas to be protected from vapor transmission.  
48 Secure in place with adhesives or other anchorage system as indicated. Extend vapor retarder to  
49 cover miscellaneous voids in insulated substrates, including those filled with loose-fiber  
50 insulation.  
51

- 52 B. Firmly attach vapor retarders to metal framing and solid substrates with vapor-retarder fasteners.  
53



- 1 C. Seal joints caused by pipes, conduits, electrical boxes, and similar items penetrating vapor  
2 retarders with vapor-retarder tape to create an airtight seal between penetrating objects and vapor  
3 retarder.  
4
- 5 D. Repair tears or punctures in vapor retarders immediately before concealment by other work.  
6 Cover with vapor-retarder tape or another layer of vapor retarder.  
7
- 8 E. Vapor retarder shall be installed in maximum material sizes so as eliminate intermediate  
9 horizontal joints and to achieve a minimum vertical joint spacing of 90-feet. The vertical joints  
10 shall have 12-inch overlaps and shall include two continuous runs of specified tape. The tape  
11 shall be used at the top and bottom seals.  
12

13 3.05 PROTECTION  
14

- 15 A. Protect installed insulation and vapor barriers from harmful weather exposures and physical  
16 abuses, by non-delayed installation of concealing work or, where that is not possible, by  
17 temporary covering or enclosure.  
18

19  
20

END OF SECTION 07 21 00

Page Intentionally Left Blank

## SECTION 07 92 00

### JOINT SEALANTS

#### PART 1 - GENERAL

##### 1.01 RELATED DOCUMENTS

- A. Conditions of the Contract and portions of Division One of this Project Manual apply to this Section as though repeated herein.

##### 1.02 WORK INCLUDED

- A. Miscellaneous Joints.

##### 1.03 RELATED WORK

- A. Hollow Metal Doors and Frames Section 08 11 13.
- B. Aluminum-Framed Entrances and Storefronts 08 41 13.

##### 1.04 SUBMITTALS

- A. Submit in accord with the General Conditions of the Contract.
  - 1. Samples: Color range of material for selection.
  - 2. Manufacturer's Recommendations including performance requirements, recommendations and application instructions for approval of materials used.

##### 1.05 PROJECT CONDITIONS

- A. Examine the joint surfaces and backing, and their anchorage to the structure, and the conditions under which the joint sealer work is to be performed. Do not proceed with the joint sealer work until unsatisfactory conditions have been corrected.
- B. Do not proceed with installation of sealants under adverse weather conditions, or when temperatures are below or above manufacturer's recommended limitations for installation. Proceed with the work only when forecasted weather conditions are favorable for proper cure and development of high early bond strength. Wherever joint width is affected by ambient temperature variations, install sealants only when temperatures are in the lower third of manufacturer's recommended installation temperature range.

#### PART 2 - PRODUCTS

##### 2.01 SEALANT

- A. Sealant for Locations Except as Specified in the Subsequent Paragraphs: PECORA Dynatrol I-XL, Degussa Sonneborn Sonolastic NP-1, TREMCO Dymonic, or other acceptable, one part polyurethane.
  - 1. Comparable means both quality and color options.
  - 2. VOC content limit: 100 g/L, less water and less exempt compounds.
- B. Horizontal Joint Sealant: PECORA NR-200 Urexpan, Sonolastic SL2, TREMCO THC-900, or other acceptable 2-part self-leveling polyurethane.
  - 1. Comparable means both quality and color options.

##### 2.02 SEALANT ACCESSORIES

- A. Primer: When required, as recommended by the Sealant Manufacturer.
- B. Closed Cell Back-up (Backer Rod): Tremco "Closed Cell Backer Rod", Sonneborne "Sonofoam" or W.R. Meadows "Kool-Rod".

### PART 3 - EXECUTION

#### 3.01 JOINT PREPARATION

- A. Clean joint surfaces immediately before installation of sealant. Remove dirt, insecure coatings, moisture and other substances which would interfere with bond of sealant. Etch concrete and masonry joint surfaces as recommended by sealant manufacturer. Roughen vitreous or glazed joint surfaces as recommended by sealant manufacturer.
- B. Prime or seal the joint surfaces wherever shown or recommended by the sealant manufacturer. Do not allow primer/sealer to spill or migrate onto adjoining surfaces.

#### 3.02 SEALANT APPLICATION, GENERAL

- A. Set joint filler units at proper depth or position in the joint to coordinate with other work, including the installation of bond breakers, backer rods and sealants. Do not leave voids or gaps between the ends of joint filler units.
- B. Install bond breaker tape wherever shown and wherever required by manufacturer's recommendations to ensure that elastomeric sealants will perform properly.
- C. Apply compound with a gun having proper size nozzle or with a knife, as required. Use sufficient pressure to fill all voids and joints solid. Remove excess sealant and leave surfaces smooth, neat and clean. Upon completion sealant shall have a smooth, even finish and all joints shall be weathertight. All work shall be in accordance with manufacturer's printed instructions.
- D. Do not allow sealants or compounds to overflow or spill onto adjoining surfaces, or to migrate into the voids of adjoining surfaces. Clean the adjoining surfaces by whatever means may be necessary to eliminate evidence of spillage.

#### 3.03 PROTECTION

- A. Cure sealants in compliance with manufacturer's instructions and recommendations. Advise the Contractor of procedures required for the cure and protection of joint sealers during the construction period, so that they will be without deterioration or damage (other than normal wear and weathering) at the time of Substantial Completion.

END OF SECTION 07 92 00

## SECTION 08 11 13

### HOLLOW METAL DOORS AND FRAMES

#### PART 1 - GENERAL

##### 1.01 RELATED DOCUMENTS

- A. Conditions of the Contract and portions of Division One of this Project Manual apply to this Section as though repeated herein.

##### 1.02 WORK INCLUDED

- A. Steel Frames.

##### 1.03 RELATED WORK

- A. Joint Sealers: Section 07 92 00.
- B. Door Hardware: Section 08 71 00.
- C. Painting: Section 09 90 00.

##### 1.04 REFERENCES

- A. Comply with Steel Door Institute "Recommended Specifications: Standard Steel Doors and Frames" (SDI-100) and as herein specified.
- B. Fire-Rated Doors: Comply with NFPA 80 "Standard for Fire Doors and Windows." and have been tested, listed, and labeled in accordance with ASTM E 152 "Standard Methods of Fire Tests of Door Assemblies" by a nationally recognized independent testing and inspection agency acceptable to authorities having jurisdiction.
- C. ANSI A250.3 Test Procedure and Acceptance Criteria for Factory Applied Finish Painted Steel Surfaces for Steel Doors and Frames.
- D. ANSI A250.4 Test Procedure and Acceptance Criteria for Physical Endurance for Steel Doors and Hardware Reinforcings.
- E. ANSI A250.5 Accelerated Physical Endurance Test Procedure for Steel Doors, Frames, and Frame Anchors.
- F. ANSI A250.8 Nomenclature for Standard Steel Doors and Steel Door Frames.
- G. ANSI A250.10 Test Procedure and Acceptance Criteria for Prime Painted Steel Surfaces for Steel Doors and Frames.
- H. ANSI/DHI A115 Specifications for Hardware Preparations in Standard Steel Doors and Frames.
- I. ANSI/DHI A115.1G Installation Guide for Doors and Hardware.
- J. SDI-105-92 Recommended Erection Instructions for Steel Frames.
- K. SDI-106 Recommended Standard Door Type Nomenclature.

- L. SDI-111 Recommended Standard Details Steel Doors and Frames.
- M. SDI-117-93 Manufacturing Tolerances Standard Steel Doors and Frames.
- N. SDI-122-90 Installation and Troubleshooting Guide for Standard Doors and Frames.
- O. ASTM E119 Methods for Fire Tests of Building Construction and Materials.
- P. ASTM A240/A240M Standard Specification for Heat-Resisting Chromium and Chromium-Nickel Stainless Steel.
- Q. ASTM A366 Standard Specification for Steel, Sheet, Carbon, Cold-Rolled, Commercial Quality.
- R. ASTM A568 Standard Specification for Steel, Sheet, Carbon, and High-Strength, Low-Alloy, Hot-Rolled and Cold-Rolled, General Requirements.
- S. ASTM A569 Standard Specification for Steel, Carbon (0.15 Maximum, Percent), Hot-Rolled Sheet and Strip Commercial Quality.
- T. ASTM A620 Standard Specification for Steel, Sheet, Carbon, Cold-Rolled, Drawing Quality, Special Killed.
- U. NFPA-101-94: Life Safety Code.
- V. NFPA 251: Fire Tests of Building Construction and Materials.
- W. NFPA 252: Fire Tests of Door Assemblies.
- X. UL 9: Fire Tests of Door Assemblies.
- Y. UL 10B: Fire Tests of Door Assemblies.
- Z. UL 263: Fire Tests of Building Construction and Materials.

#### 1.05 SUBMITTALS

- A. Submit in accordance with the General Requirements of the Contract.
  1. Manufacturer's technical product data substantiating that products comply with requirements.
  2. Shop Drawings for fabrication and installation of steel doors and frames. Include details of each frame type, elevations of door design types, conditions at openings, details of construction, location and installation requirements of finish hardware and reinforcements, and details of joints and connections. Show anchorage and accessory items.
    - a. Provide schedule of doors and frames using same reference numbers for details and openings as those on contract drawings.
    - b. Indicate coordination of glazing frames and stops with glass and glazing requirements.

#### 1.06 QUALITY ASSURANCE

- A. Comply with requirements of Steel Door Institute Standard SDI-100, "Recommended Specifications for Standard Steel Door and Frames", U.S. Department of Commerce Standard PS4-66, relative to manufacture of 1-314 inch thick flush steel doors, and applicable requirements of ANSI A115.

- B. Factory machine frames for hardware requiring routing and mortising.
- C. Fire-Rated Door Assemblies: Label, testing and installation of opening protectives shall be in accordance with Wisconsin Building Code Section 715.
  - 1. Oversize Fire-Rated Door Assemblies: For units exceeding sizes of tested assemblies, provide certification by a qualified testing agency that doors comply with standard construction requirements for tested and labeled fire-rated door assemblies except for size.
- D. Smoke-Control Door Assemblies: Comply with NFPA 105 or UL 1784.

#### 1.07 DELIVERY, STORAGE, AND HANDLING

- A. Deliver hollow metal work in cartons or crates to provide protection during transit and job storage.
- B. Inspect hollow metal work upon delivery for damage. Minor damages may be repaired provided refinished items are equal in all respects to new work and acceptable to AE; otherwise, remove and replace damaged items as directed.
- C. Store doors and frames at building site under cover. Place units on minimum 4 inch high wood blocking. Avoid use of non-vented plastic or canvas shelters which could create a humidity chamber. If cardboard wrapper on door becomes wet, remove carton immediately. Provide 1/4 inch spaces between stacked doors to promote air circulation.

#### 1.08 PROJECT CONDITIONS

- A. Examine the openings and conditions under which hollow metal work is to be installed. Do not proceed with the work until unsatisfactory conditions have been corrected.

### PART 2 - PRODUCTS

#### 2.01 MANUFACTURERS

- A. Anweld Building Products
- B. Benchmark Commercial Doors
- C. Ceco Door Products
- D. Curries Company
- E. Deansteel Manufacturing Co.
- F. Fenestra, Inc.
- G. Kewaunee Corporation
- H. Krieger Steel Products
- I. Mesker Door , Inc.
- J. Pioneer Industries, Inc.

- K. Precision Metals, Inc.
- L. Republic Builder Products
- M. Security Metal Products Corp.
- N. Steelcraft
- O. Trussbuilt, Inc.
- P. Williamsburg Steel Products Co
- Q. Or approved equal.

## 2.02 MATERIALS

- A. Steel: Commercial quality, level, cold-rolled steel conforming to ASTM A366, free of scale and surface defects. Commercial quality hot rolled and pickled steel conforming to ASTM A569 may be used as option for interior frames. Gauges are as follows:
  - 1. Interior Frames: 16-gage.
  - 2. Rough Bucks and Stiffeners: 12-gage.
  - 3. Miscellaneous Trim: 16 gage.

## 2.03 FABRICATION, GENERAL

- A. Make hardware mortises and reinforcements according to templates. Provide hinge, lock, door holder and closer hardware reinforcements. Mortise, drill tap for hardware; fabricate grooves, rabbets as necessary for weatherstripping.
- B. Provide proper Underwriters' Laboratory (UL) labels. Labeled doors shall have equal labeled frames.
- C. Clearances
  - 1. Edge clearances shall be provided as follows:
    - a. Between doors and frame, at head and jambs - 1/8 inch.
    - b. At door sills:
      - 1) Where no threshold is used - 3/8 minimum.
      - 2) Where threshold is used - 1/4 inch maximum between door & threshold.

## 2.04 HOLLOW METAL FRAME FABRICATION

- A. Provide metal frames of the types and styles indicated on the drawings or schedules and complying with SDI 100 for materials and construction requirements.
- B. Provide metal frames for doors, transoms, sidelights, borrowed lights, and other openings, as shown on drawings.
- C. All frames shall have mitered corners, be internally welded and ground smooth and provided with floor anchors.
- D. Provide one removable and one fixed stop at perimeter of openings for glazed frames. Removable stop on secure side.



- E. Provide closed metal covers over all hardware cutouts to protect against mortar.
- F. Provide integral channel frames, sub-frames and stiffeners to structure where indicated or required for fastening and stiffening frames.
- G. Provide steel spreader temporarily attached to feet of both jambs for welded frames.
- H. Provide three factory installed silencers on single door frames at strike jamb.
- I. Completely clean all frames by degreasing process, followed by one coat rust inhibitive primer equal to withstand a salt spray test (5% solution) of 70 hours. Thoroughly prime all surfaces without runs, smears, or bare spots, and under and inside all removable stops.
- J. Where required frames to be prepped for electric strike.
- K. Door Silencers: Except on weather-stripped doors, drill stops to receive door silencers as follows. Keep holes clear during construction.
  - a. Single-Door Frames: Drill stop in strike jamb to receive three door silencers.
  - b. Double-Door Frames: Drill stop in head jamb to receive two door silencers.

### PART 3 - EXECUTION

#### 3.01 INSTALLATION

- A. Install steel frames, and accessories in accordance with final shop drawings, manufacturer's data, and as herein specified.
- B. Comply with provisions of SDI-105 "Recommended Erection Instructions for Steel Frames", unless otherwise indicated.
  - 1. Except for frames located at in-place concrete or masonry and at drywall installations, place frames prior to construction of enclosing walls and ceilings. Set frames accurately in position, plumbed, aligned, and braced securely until permanent anchors are set. After wall construction is completed, remove temporary braces and spreaders leaving surfaces smooth and undamaged.
  - 2. In metal stud partitions, install at least 3 wall anchors per jamb at hinge and strike levels. In open steel stud partitions, place studs in wall anchor notches and wire tie. In closed steel stud partitions, attach wall anchors to studs with self-tapping screws.
  - 3. Fill heads of fasteners with body putty, grind smooth and touch-up prime.
- C. Install hollow metal frames of size and profile indicated. Comply with ANSI/SDI A250.11.
  - 1. Set frames accurately in position, plumbed, aligned, and braced securely until permanent anchors are set. After wall construction is complete, remove temporary braces, leaving surfaces smooth and undamaged.
    - a. At fire-protection-rated openings, install frames according to NFPA 80.
    - b. Where frames are fabricated in sections because of shipping or handling limitations, field splice at approved locations by welding face joint continuously; grind, fill, dress, and make splice smooth, flush, and invisible on exposed faces.
    - c. Install frames with removable glazing stops located on secure side of opening.
    - d. Install door silencers in frames before grouting.
    - e. Remove temporary braces necessary for installation only after frames have been properly set and secured.
    - f. Check plumbness, squareness, and twist of frames as walls are constructed. Shim as necessary to comply with installation tolerances.

- g. Field apply bituminous coating to backs of frames that are filled with grout containing antifreezing agents.

3.02 ADJUSTING

- A. Immediately after erection sand smooth any rusted or damaged areas of prime coat and apply touch-up of compatible air-drying primer.
- B. Check and readjust operating finish hardware items, leaving steel frames undamaged and in complete and proper operating condition.

END OF SECTION 08 11 13

SECTION 08 14 16  
FLUSH WOOD DOORS

PART 1 - GENERAL

1.01 RELATED DOCUMENTS

- A. Conditions of the Contract and portions of Division One of this Project Manual apply to this Section as though repeated herein.

1.02 WORK INCLUDED

- A. Wood Doors

1.03 RELATED WORK

- A. Hollow Metal Doors and Frames: Section 08 11 13.
- B. Door Hardware: Section 08 71 00.
- C. Glass and Glazing: Section 08 80 00.
- D. Painting: Section 09 90 00, for re-finishing of planed and cut surfaces.

1.04 REFERENCES

- A. Reference Standards: Section 1300 of the Architectural Woodwork Institute (AWI). Door types specified in Part 2 below are AWI reference designations.
- B. Doors: Obtained from a single manufacturer.

1.05 SUBMITTALS

- A. Submit in accordance with the General Conditions of the Contract
  1. Manufacturer's product data, specifications and installation instructions for each type of wood door.
    - a. Including information on recycled content.
  2. Color charts of wood finishes for initial selection.
  3. (2) 10" x 10" wood samples with finish for final selection.

1.06 DELIVERY, STORAGE AND HANDLING

- A. Protect wood doors during transit, storage and handling to prevent damage, soiling and deterioration. Comply with the "on-site care" recommendations of National Wood Window and Door Association (WDMA) pamphlet "Care and Finishing Wood Doors" and with manufacturer's instructions.
  1. Provide protective coverings for doors at the factory prior to shipping. Use heavy paper cartons or poly bags and mark with identification required for proper installation.
- B. Deliver and store within enclosed building only after humidity contributing work is completed and relative humidity is less than 50%. Stack doors laid flat, level and off floor, in dry, clean, well ventilated space.
- C. Do not drag doors across one another.

1.07 WARRANTY

- A. Submit in duplicate manufacturer's written warranty per NWWDA Standard Door warranty but extending for life of installation for interior solid core doors, including refinishing and re-hanging costs for replacement doors.

PART 2 - PRODUCTS

2.01 MANUFACTURERS

- A. Algoma Hardwoods, Inc.; Algoma, Wisconsin; (920) 487-5221.
- B. Eggers Industries; Two Rivers, Wisconsin: (920) 793-1351.
- C. Graham Division, Assa Abloy Door Group LLC; Mason City, Iowa: (641) 423-2444.
- D. Mohawk Flush Doors, Inc.; South Bend, Indiana: (574) 288-4464.
- E. Marshfield Door Systems; Marshfield, Wisconsin: (800) 869-3667.
- F. Oshkosh Architectural Door Company; Oshkosh, Wisconsin: (920) 233-6161.
- G. VT Industries; Holstein, Iowa; (800) 827-1615.

2.02 MANUFACTURED UNITS

- A. Non-labeled Interior Wood Veneer Solid Core Doors: AWI type PC-5/7, Custom Grade.
  - 1. Core: Particleboard or agri-fiber with minimum 40% post-industrial, recycled content as certified by an independent, third party certification agency.
  - 2. Veneer: Book matched, Red Oak, Rift Cut.
  - 3. Species of stiles to match face veneer.
  - 4. Transparent Finish: Factory finish to AWI section 1500, Custom standards.
    - a. Water-based stain with ultra-violet (UV) cured topcoats.
    - b. Sheen: Satin.
  - 5. Color: Finish to match stain finish of existing wood doors, as approved by A/E.
- B. Labeled Interior Wood Veneer Solid Core Doors: AWI FD.
  - 1. Edge Banding: Laminated.
  - 2. Veneer: Same as non-labeled doors.
  - 3. Species of stiles to match face veneer.
  - 4. Transparent Finish: Factory finish to AWI section 1500, Custom standards.
    - a. Water-based stain with ultra-violet (UV) cured topcoats.
    - b. Sheen: Satin.
  - 5. Color: Finish to match stain finish of existing wood doors, Algoma custom stain RA-17257 or LaForce Masonite Custom Color 256052C, as approved by A/E. Match existing adjacent doors.
  - 6. Provide mineral core blocking at closers.
- C. Hardware location per manufacturer's recommendations to meet ADA requirements.
- D. Glazed Openings
  - 1. Provide factory glazed units.
  - 2. Cut openings.
  - 3. At non-labeled doors, provide detailed stops of same species as wood veneer.

### PART 3 - EXECUTION

#### 3.01 EXAMINATION

- A. Verify that door frames are of type required for door and are installed as required for proper installation of doors.
- B. Do not install doors in frames which would hinder the operation of the doors.

#### 3.02 INSTALLATION

- A. Do not install in improperly installed frames.
- B. Fit for width by planing. For height, saw, first from bottom, then not over 1/2 inch from top. Bevel lock and hinges edge 1/8 inch in 2 inches.
- C. Provide 3/32 inch clearance between door and frame and 3/8 inch clearance between bottom of door and finish flooring.
- D. Seal all job site cut surfaces with stain to match existing and two coats of varnish.

#### 3.03 ADJUST AND CLEAN

- A. Replace or re-hang doors which are hingebound and do not swing or operate properly.
- B. Refinish or replace job finished doors damaged prior to Substantial Completion.

END OF SECTION 08 14 00

Page Intentionally Left Blank

SECTION 08 31 13

ACCESS DOORS AND FRAMES

PART 1 - GENERAL

1.01 RELATED WORK

- A. Conditions of the Contract and portions of Division One of this Project Manual apply to this Section as though repeated herein.

1.02 SUMMARY

- A. This section includes the following:
  - 1. Access doors and frames.
  - 2. Fire resistive rated access doors and frames.
- B. Related sections include the following:
  - 1. Division 23 Section "Duct Accessories" for duct access doors.

1.03 SUBMITTALS

- A. Submit in accord with the General Conditions of the Contract.
  - 1. Coordination Drawings: Reflected ceiling plans drawn to scale and coordinating penetrations and ceiling-mounted items with concealed framing, suspension systems, piping, ductwork, and other construction. Show the following
    - a. Method of attaching door frames to surrounding construction.
    - b. Ceiling-mounted items including access doors and frames, lighting fixtures, diffusers, grilles, and special trim.
    - c. Underwriters Laboratories, Inc. (UL) UL10B-2008, Fire Tests of Door Assemblies.

1.04 QUALITY ASSURANCE

- A. Source Limitations: Obtain doors and frames through one source from a single manufacturer.
- B. Size Variations: Obtain Architect's acceptance of manufacturer's standard-size units, which may vary slightly from sizes indicated.
- C. Wherever a fire-resistance classification is required, provided access assembly with panel, frame, hinge and latch from manufacturer listed in the Intertek Listed Products Directory.
  - 1. Provide Intertek Warnock Hersey Label on each fire-rated access panel.

1.05 ENVIRONMENTAL REQUIREMENTS

- A. Low-Emitting Materials, Field applied Paints and Coatings: Interior paints and coatings applied on-site must meet the limitations and restrictions concerning chemical components set by the following standards:
  - 1. Anti-Corrosive and Anti-Rust Paints: Green Seal Standard GS-03, Anti-Corrosive Paints", Second Edition, January 7, 1997. For applications on ferrous metal substrates.
  - 2. "All Other Architectural Coatings, Primers and Undercoats: South Coast Air Quality Management District (SCAQMD) Rule #1113, Architectural Coatings", rules in effect on January 1, 2004.

PART 2 - PRODUCTS

1 2.01 MANUFACTURERS

- 2  
3 A. Manufacturers: Subject to compliance with requirements, provide products by one of the  
4 following:  
5 1. Access Doors:  
6 a. Bar-Co, Inc. Div.; Alfab, Inc.  
7 b. Cesco Products.  
8 c. J. L. Industries, Inc.  
9 d. Karp Associates, Inc.  
10 e. Milcor Limited Partnership.

11  
12 2.02 MATERIALS

- 13  
14 A. Hot-Rolled Steel Sheets: ASTM A 569/A 569M, Commercial Steel (CS), Type B; free of scale,  
15 pitting, and surface defects; pickled and oiled; with minimum thickness indicated representing  
16 specified nominal thickness according to ASTM A 568/A 568M.  
17  
18 B. Cold-Rolled Steel Sheets: ASTM A 366/A 366M, Commercial Steel (CS), or  
19 ASTM A 620/A 620M, Drawing Steel (DS), Type B; stretcher-leveled standard of flatness; with  
20 minimum thickness indicated representing specified nominal thickness according to  
21 ASTM A 568/A 568M. Electrolytic zinc-coated steel sheet, complying with  
22 ASTM A 591/A 591M, Class C coating, may be substituted at fabricator's option.  
23  
24 C. Metallic-Coated Steel Sheet: ASTM A 653/A 653M, Commercial Steel (CS), Type B, with A60  
25 zinc-iron-alloy (galvannealed); stretcher-leveled standard of flatness; with minimum thickness  
26 indicated representing specified thickness according to ASTM A 924/A 924M.  
27  
28 D. Drywall Beads: Edge trim formed from 0.0299-inch zinc-coated steel sheet formed to receive  
29 joint compound and in size to suit thickness of gypsum board.

30  
31 2.03 PAINT

- 32  
33 A. Shop Primers: Provide primers that comply with Division 9 Section "Painting."  
34  
35 B. Shop Primer for Ferrous Metal: Fast-curing, lead- and chromate-free, universal modified-alkyd  
36 primer complying with performance requirements in FS TT-P-664; selected for good resistance  
37 to normal atmospheric corrosion, compatibility with finish paint systems indicated, and  
38 capability to provide a sound foundation for field-applied topcoats despite prolonged exposure.  
39  
40 C. Shop Primer for Metallic-Coated Steel: Organic zinc-rich primer complying with SSPC-  
41 Paint 20 and compatible with topcoat.  
42  
43 D. Galvanizing Repair Paint: High-zinc-dust-content paint for re-galvanizing welds in steel,  
44 complying with SSPC-Paint 20.  
45

46 2.04 ACCESS DOORS AND FRAMES

- 47  
48 A. Flush Access Doors and Trimless Frames: Fabricated from metallic-coated steel sheet.  
49 1. Locations: Various locations and surfaces, assembly to be manufactured for specific  
50 applications.  
51 2. Sizes: 18" x 18", as shown in drawings or to match existing openings.  
52 3. Door: Sheet metal, gauged to door size, minimum 20 gauge metal set flush with  
53 surrounding finish surfaces.  
54 4. Frame: To be manufactured specifically for the surrounding material for flush/integral  
55 installation, minimum 16 gauge metal flange.  
56 a. Drywall bead for gypsum board.



- 1                   b.     Other as needed.  
2  
3           5.     Hinges:  
4           a.     Spring-loaded concealed pin type.  
5  
6           6.     Latch:  
7           a.     Screwdriver-operated cam latch.  
8           b.     Key operated security lock.  
9           c.     Or self latching at rated conditions.

10  
11   2.05    FABRICATION

- 12  
13       A.    General: Provide access door assemblies manufactured as integral units ready for installation.  
14  
15       B.    Metal Surfaces: For metal surfaces exposed to view in the completed Work, provide materials  
16           with smooth, flat surfaces without blemishes. Do not use materials with exposed pitting, seam  
17           marks, roller marks, rolled trade names, or roughness.  
18  
19       C.    Steel Doors and Frames: Grind exposed welds smooth and flush with adjacent surfaces.  
20           Furnish attachment devices and fasteners of type required to secure access panels to types of  
21           supports indicated.  
22  
23       D.    For trimless frames with drywall bead for installation in gypsum board assembly, provide edge  
24           trim for gypsum board securely attached to perimeter of frames.  
25  
26       E.    Latching Mechanisms: Furnish number required to hold doors in flush, smooth plane when  
27           closed.  
28  
29       F.    All access doors to be fabricated and properly installed in such a manner as to maintain the fire  
30           rating of the assembly into which it is placed.  
31  
32       G.    Fire-Rated Access Panels and Frames: Units complying with NFPA 80 that are identical to  
33           access panel and frame assemblies tested for fire-test-response characteristics according to the  
34           following test method, and that are listed and labeled by UL or another testing and inspecting  
35           agency acceptable to authorities having jurisdiction.  
36

37   2.06    FINISHES, GENERAL

- 38  
39       A.    Comply with NAAMM's "Metal Finishes Manual for Architectural and Metal Products" for  
40           recommendations for applying and designating finishes.  
41  
42       B.    Finish metal fabrications after assembly.  
43

44   2.07    METALLIC-COATED STEEL FINISHES

- 45  
46       A.    Galvanizing of Steel Shapes and Plates: Hot-dip galvanize items indicated to comply with  
47           applicable standard listed below:  
48           1.     ASTM A 123/A 123M, for galvanizing steel and iron products.  
49           2.     ASTM A 153/A 153M, for galvanizing steel and iron hardware.  
50  
51       B.    Surface Preparation: Clean surfaces with nonpetroleum solvent so surfaces are free of oil and  
52           other contaminants. For galvanized surfaces, apply, after cleaning, a conversion coating suited  
53           to the organic coating to be applied over it. For metallic-coated surfaces, clean welds,  
54           mechanical connections, and abraded areas, and apply galvanizing repair paint specified below  
55           to comply with ASTM A 780.



SECTION 08 41 13

ALUMINUM-FRAMED ENTRANCES AND STOREFRONTS

PART 1 - GENERAL

1.01 RELATED DOCUMENTS

- A. Conditions of the Contract and portions of Division One of this Project Manual apply to this Section as though repeated herein.

1.02 WORK INCLUDED

- A. Aluminum Frames.
- B. Glazing.
- C. Accessories for a Complete Installation.
- D. 18 ga. break metal to match storefront at detail 13A7.0.

1.03 RELATED WORK

- A. Section 07 92 00, Joint Sealants.
- B. Section 08 80 00, Glass and Glazing.

1.04 QUALITY ASSURANCE

- A. Installer shall be an authorized representative of the door manufacturer for both installation and maintenance of type of units required for this Project.
- B. Installer: Not less than 2 year's experience in the installation and service of entrance doors of the same manufacturer.
- C. Fenestration must comply with a minimum testing performance requirements for an AAMA/NWWDA 101/1.S.2 HC-40 rating. The recognized standard for performance ratings of windows is AAMA/NWWDA 101/1.S.2.
- D. Comply with the manufacturers requirements and the following. In case of conflict, comply with the most stringent.
  - 1. NAAMM-Metal Finishes Manual, National Association of Architectural Metal Manufacturers.
  - 2. ASTM B221- Specification for Aluminum and Aluminum-Alloy Extruded Bars, Rods, Wires, Shapes and Tubes.
  - 3. ASTM B244 – Method for Measurement of Thickness of Anodic Coatings on Aluminum and of Other Nonconductive Coatings on Nonmagnetic Basis Metals With Eddy-Current Instructions.

1.05 SUBMITTALS

- A. Submit in accordance with the General Conditions of the Contract
  - 1. Manufacturer's product data and standard details, including fabrication, finishing, hardware, accessories and other components of the work. Include roughing-in diagrams, wiring diagrams, parts lists, and maintenance instructions.

2. Furnish templates, diagrams and other data to fabricators and installers of related work as needed for coordination of installation.
3. Shop Drawings: Indicate anchors, joint system, expansion provisions, hardware, and other components not included in manufacturer's standard data. Include glazing details.
4. Samples
  - a. Frame Color: Two 10-inch extrusions with finish, properly labeled.
  - b. Glass: Two 8 x 8 -inch square samples of each glass type indicated, properly labeled.
  - c. Corner of Frame: Sample to include fit, finish and tolerance of frame corner joint.
5. Owner's Manual: Submitted prior to Substantial Completion. Include recommendations for maintenance, repair.

#### 1.06 INSULATED GLASS, GLAZING, ENTRANCE/STOREFRONT INSTALLATION WARRANTY

- A. Manufacturer's Special Warranty on Insulating Glass: Manufacturer's standard form in which insulating-glass manufacturer agrees to replace insulating-glass units that deteriorate within specified warranty period. Deterioration of insulating glass is defined as failure of hermetic seal under normal use that is not attributed to glass breakage or to maintaining and cleaning insulating glass contrary to manufacturer's written instructions. Evidence of failure is the obstruction of vision by dust, moisture, or film on interior surfaces of glass.
  1. Warranty Period: 10 years from date of Substantial Completion.

#### 1.07 MANUFACTURER/FABRICATOR AND INSTALLER QUALIFICATIONS

- A. Fenestration systems must be fabricated by a firm experienced in production of systems similar to those indicated, whose work has resulted in a record of successful in-service performance during the immediate past three years. The fabricator should have sufficient production capacity to produce required components without causing delays in the work.
- B. Fenestration systems must be installed by an experienced installer, having completed installations of fenestration similar in design and extent to those required for the project whose work has resulted in construction with a record of successful in-service performance during the immediate past three years.

#### 1.08 ENVIRONMENTAL REQUIREMENTS

- A. Low-Emitting Materials, Adhesives, and Sealants: Materials used on the interior of the building (defined as inside the weatherproofing system and applied on site) must not exceed the following requirements.
  1. Adhesives, Sealants and Sealant Primers: South Coast Air Quality Management (SCAQMD) Rule # 1168, requirements in effect on July 1, 2005, and rule amendment date January 7, 2005.
  2. Aerosol Adhesives: Green Seal Standard for Commercial Adhesives GS-36, requirements in effect on October 19, 2000.
- B. Recycled Content of Aluminum Materials: Provide aluminum materials containing the maximum possible amount of postconsumer and preconsumer recycled aluminum content.
- C. Recycled Content of Steel Materials: Provide steel materials manufactured domestically using the electric arc furnace method and containing the maximum possible amount of postconsumer and preconsumer recycled steel content.

### PART 2 - PRODUCTS

#### 2.01 MAUFACTURERS

- A. Exterior Basis-of-Design Product: Subject to compliance with requirements, provide Trifab 451T (Exterior conditions) with thermal break by Kawneer North America; an Alcoa company.
  1. Types of Kawneer Aluminum Storefront Systems include:
    - a. Type 1: Trifab® VG 451T Storefront System – 2" x 4-1/2" nominal dimension; Thermal; Glazing application as indicated on drawings; Stick Fabrication.

- 1  
2  
3 B. Or comparable product by one of the following:  
4 1. CMI Architectural  
5 2. EFCO Corporation.  
6 3. TRACO.  
7 4. Tubelite.  
8 5. Vistawall Architectural Products; The Vistawall Group; a Bluescope Steel company.  
9 6. YKK AP America Inc.

10  
11 2.02 MATERIALS  
12

- 13 A. Aluminum: Alloy and temper recommended by manufacturer for type of use and finish indicated.  
14 1. Sheet and Plate: ASTM B 209.  
15 2. Extruded Bars, Rods, Profiles, and Tubes: ASTM B 221.  
16 3. Extruded Structural Pipe and Tubes: ASTM B 429.  
17 4. Structural Profiles: ASTM B 308/B 308M.  
18 5. Welding Rods and Bare Electrodes: AWS A5.10/A5.10M.  
19  
20 B. Steel Reinforcement: Manufacturer's standard zinc-rich, corrosion-resistant primer, complying with SSPC-PS  
21 Guide No. 12.00; applied immediately after surface preparation and pretreatment. Select surface preparation  
22 methods according to recommendations in SSPCSP COM and prepare surfaces according to applicable SSPC  
23 standard.  
24 1. Structural Shapes, Plates, and Bars: ASTM A 36/A 36M.  
25 2. Cold-Rolled Sheet and Strip: ASTM A 1008/A 1008M.  
26 3. Hot-Rolled Sheet and Strip: ASTM A 1011/A 1011M.  
27

28 2.03 FRAMING SYSTEMS  
29

- 30 A. Framing Members: Manufacturer's standard extruded-aluminum framing members of thickness required and  
31 reinforced as required to support imposed loads.  
32 1. Construction: Thermally improved at exterior condition.  
33 2. Glazing System: Retained mechanically with gaskets on four sides.  
34 3. Glazing Plane: As indicated.  
35  
36 B. Brackets and Reinforcements: Manufacturer's standard high-strength aluminum with nonstaining, nonferrous  
37 shims for aligning system components.  
38  
39 C. Fasteners and Accessories: Manufacturer's standard corrosion-resistant, nonstaining, nonbleeding fasteners  
40 and accessories compatible with adjacent materials.  
41 1. Use self-locking devices where fasteners are subject to loosening or turning out from thermal and  
42 structural movements, wind loads, or vibration.  
43 2. Reinforce members as required to receive fastener threads.  
44  
45 D. Concrete and Masonry Inserts: Hot-dip galvanized cast-iron, malleable-iron, or steel inserts, complying with  
46 ASTM A 123/A 123M or ASTM A 153/A 153M.  
47  
48 E. Concealed Flashing: Manufacturer's standard corrosion-resistant, nonstaining, nonbleeding flashing  
49 compatible with adjacent materials.  
50  
51 F. Framing System Gaskets and Sealants: Manufacturer's standard, recommended by manufacturer for joint type.  
52

53 2.04 GLAZING SYSTEMS  
54

- 55 A. Glazing: As specified in Division 08 Section "Glazing."  
56

- 1 B. Glazing Gaskets: Manufacturer's standard compression types; replaceable, molded or extruded, of profile and  
2 hardness required to maintain watertight seal.  
3
- 4 C. Spacers and Setting Blocks: Manufacturer's standard elastomeric type.  
5
- 6 2.05 ACCESSORY MATERIALS  
7
- 8 A. Joint Sealants: For installation at perimeter of aluminum-framed systems, as specified in Division 07 Section  
9 "Joint Sealants."  
10
- 11 B. Bituminous Paint: Cold-applied, asphalt-mastic paint complying with SSPC-Paint 12 requirements except  
12 containing no asbestos; formulated for 30-mil (0.762-mm) thickness per coat.  
13
- 14 2.06 GLASS  
15
- 16 A. Glass: See Section 08 80 00 for glass to be supplied and installed under this section.  
17
- 18 2.07 GLAZING ACCESSORIES  
19
- 20 A. Glazing Sealant: One-part silicone similar to Pecora 860, Sonneborn Omniplus or Tremco Spectrum 2.  
21 1. Comparable means both quality and color options.  
22
- 23 B. Setting Blocks: 70-90 Shore "A" durometer, sized to accommodate size of glass used, compatible with  
24 glazing sealant.  
25
- 26 C. Spacers: Compatible with sealant used.  
27
- 28 D. Primer, Sealers, Cleaners: As recommended by glass manufacturer.  
29
- 30 E. Aluminum Stops: Pierced and/or fixed stop, finish to match aluminum framing.  
31 1. Dark Bronze Anodized, field verify.  
32
- 33 2.08 FABRICATION  
34
- 35 A. Form or extrude aluminum shapes before finishing.  
36
- 37 B. Weld in concealed locations to greatest extent possible to minimize distortion or discoloration of finish.  
38 Remove weld spatter and welding oxides from exposed surfaces by descaling or grinding.  
39
- 40 C. Framing Members, General: Fabricate components that, when assembled, have the following characteristics:  
41 1. Profiles that are sharp, straight, and free of defects or deformations.  
42 2. Accurately fitted joints with ends coped or mitered.  
43 3. Means to drain water passing joints, condensation within framing members, and moisture migrating  
44 within the system to exterior.  
45 4. Physical and thermal isolation of glazing from framing members.  
46 5. Accommodations for thermal and mechanical movements of glazing and framing to maintain required  
47 glazing edge clearances.  
48 6. Provisions for field replacement of glazing from interior.  
49 7. Fasteners, anchors, and connection devices that are concealed from view to greatest extent possible.  
50
- 51 D. Mechanically Glazed Framing Members: Fabricate for flush glazing without projecting stops.  
52
- 53 E. Storefront Framing: Fabricate components for assembly using shear-block system.  
54
- 55 F. After fabrication, clearly mark components to identify their locations in Project according to Shop Drawings.  
56

- 1 2.09 ALUMINUM FINISHES  
2  
3 A. Anodized to match existing. Dark Bronze, field verify.  
4
- 5 PART 3 - EXECUTION  
6
- 7 3.01 EXAMINATION  
8
- 9 A. Examine areas and conditions, with Installer present, for compliance with requirements for installation  
10 tolerances and other conditions affecting performance of the Work.  
11  
12 B. Proceed with installation only after unsatisfactory conditions have been corrected.  
13
- 14 3.02 INSTALLATION  
15
- 16 A. General:  
17 1. Comply with manufacturer's written instructions.  
18 2. Do not install damaged components.  
19 3. Fit joints to produce hairline joints free of burrs and distortion.  
20 4. Rigidly secure nonmovement joints.  
21 5. Install anchors with separators and isolators to prevent metal corrosion and electrolytic deterioration.  
22 6. Seal joints watertight unless otherwise indicated.  
23
- 24 B. Metal Protection:  
25 1. Where aluminum will contact dissimilar metals, protect against galvanic action by painting contact  
26 surfaces with primer or applying sealant or tape, or by installing nonconductive spacers as  
27 recommended by manufacturer for this purpose.  
28 2. Where aluminum will contact concrete or masonry, protect against corrosion by painting contact  
29 surfaces with bituminous paint.  
30
- 31 C. Install components to drain water passing joints, condensation occurring within framing members, and  
32 moisture migrating within the system to exterior.  
33 D. Set continuous sill members and flashing in full sealant bed as specified in Division 07 Section "Joint  
34 Sealants" to produce weathertight installation.  
35
- 36 E. Install components plumb and true in alignment with established lines and grades, and without warp or rack.  
37
- 38 F. Install glazing as specified in Division 08 Section "Glazing."  
39
- 40 G. Install perimeter joint sealants as specified in Division 07 Section "Joint Sealants" to produce weathertight  
41 installation.  
42
- 43 3.03 ERECTION TOLERANCES  
44
- 45 A. Install aluminum-framed systems to comply with the following maximum erection tolerances:  
46 1. Location and Plane: Limit variation from true location and plane to 1/8 inch in 12 feet; 1/4 inch over  
47 total length.  
48 2. Alignment:  
49 a. Where surfaces abut in line, limit offset from true alignment to 1/16 inch.  
50 b. Where surfaces meet at corners, limit offset from true alignment to 1/32 inch.  
51
- 52 B. Diagonal Measurements: Limit difference between diagonal measurements to 1/8 inch.  
53
- 54 3.04 FIELD QUALITY CONTROL  
55
- 56 A. Testing Agency: a qualified independent testing and inspecting agency to perform field tests and inspections.

1  
2  
3  
4  
5  
6  
7  
8  
9  
10  
11  
12  
13  
14  
15  
16  
17  
18  
19  
20

- B. Testing Services: Testing and inspecting of representative areas to determine compliance of installed systems with specified requirements shall take place as follows and in successive phases as indicated on Drawings. Do not proceed with installation of the next area until test results for previously completed areas show compliance with requirements.
  - 1. Water Spray Test: Before installation of interior finishes has begun, a minimum area of 75 feet by 1 story of aluminum-framed systems designated by Architect shall be tested according to AAMA 501.2 and shall not evidence water penetration.
- C. Repair or remove work if test results and inspections indicate that it does not comply with specified requirements.
- D. Additional testing and inspecting, at Contractor's expense, will be performed to determine compliance of replaced or additional work with specified requirements.
- E. Aluminum-framed assemblies will be considered defective if they do not pass tests and inspections.
- F. Prepare test and inspection reports.

END OF SECTION 08 41 13



## SECTION 08 71 00

### DOOR HARDWARE

#### PART 1 - GENERAL

##### 1.01 RELATED DOCUMENTS

- A. Conditions of the Contract and portions of Division One of this Project Manual apply to this Section as though repeated herein.

##### 1.02 WORK INCLUDED

- A. Door Hardware

##### 1.03 RELATED SECTIONS

- A. Hollow Metal Doors and Frames: Section 08 11 13.
- B. Flush Wood Doors: Section 08 14 16.

##### 1.04 REFERENCES

- A. Federal Specifications (FS)
  - 1. FF-H-106a Hardware, Builders'; Locks and Door Trim-Standard Finishes for Builders Hardware.
- B. National Fire Protection Association, Inc. (NFPA), Battery March Park, Quincy, MA 02269.
  - 1. NFPA 80 - Standard for fire doors and windows.
  - 2. NFPA 101 - Code for safety to life from fire in buildings and structures.
- C. Underwriter's Laboratories, Inc. (UL), 333 Pfingsten Road, Northbrook, IL 60062.
  - 1. Building Materials Directory.
- D. Hardware shall be in strict accord with Wisconsin Administrative Code Chapter Comm. 69 - "Barrier Free Design".

##### 1.05 SUBMITTALS

- A. Submit in accordance with the General Conditions of the Contract.
  - 1. Five (5) copies of a detailed, vertical type hardware schedule for approval.
    - a. List and describe each opening separately. Include doors with identical hardware, except hand, in a single heading. Include door number, room designations, degree of swing, and hand.
    - b. List related details. Include dimensions, door and frame material, and other conditions affecting hardware.
    - c. List all hardware items. Include manufacturer's name, quantity, product name, catalog number, size, finish, attachments, and related details.
    - d. Resubmit four (4) copies of the corrected schedule when required.
    - e. Determine keying requirements, as directed by the Owner's Representative and submit five (5) copies of a detailed keying schedule for approval; resubmit four copies (4) of the corrected schedule when required. Reinstalled salvaged hardware is included in the scope of the work.
  - 2. Samples of hardware items as may be required. Identify each sample and indicate the location of subsequent installation in the project.

3. A copy of the approved hardware schedule and all pertinent templates or template information to each fabricator of material factory-prepared for the installation of hardware.

#### 1.06 QUALITY ASSURANCE

- A. Manufacturers and product numbers listed herein establish a standard of quality. Similar items by other manufacturers may be accepted by prior approval in accord with the General Conditions of the Contract. Except where specified in the hardware schedule, furnish products of only one manufacturer for each type of hardware.
- B. Supplier: Hardware Supplier: The hardware supplier shall be a corporate member in good standing of The Door and Hardware Institute (DHI), employing at least one Architectural Hardware Consultant (AHC) who is currently participating in DHI's continuing education program (CEP).
- C. Items of hardware not definitely specified herein but necessary for completion of the Work shall be provided. Such items shall be of type and quality suitable to the service required and comparable to the adjacent hardware. Where size and shape of members is such as to prevent the use of types specified, hardware shall be furnished of suitable types having as nearly as practicable the same operation and quality as the type specified. Sizes shall be adequate for the service required. Include such nuances as strike type, strike lip, raised barrel hinges, mounting brackets, fasteners, shims, and coordination between conflicting products. All doors shall be provided with a stop.

#### 1.07 REGULATORY REQUIREMENTS

- A. Furnish UL listed hardware for all UL labeled openings in conformance with requirements for the class of opening scheduled.

#### 1.08 DELIVERY, STORAGE AND HANDLING

- A. Deliver hardware to the job site in the manufacturer's original containers marked to correspond with the approved hardware schedule for installation location.
- B. Store hardware in dry surroundings and protect against loss and damage.

### PART 2 - PRODUCTS

#### 2.01 MANUFACTURERS

- A. Refer to the Hardware Schedule at the end of this Section.

#### 2.02 ACCESSORIES

- A. Furnish all necessary hardware accessories such as wood or machine screws, bolts, nuts, anchors, toggle bolts, and other fasteners, each of the type, size, material and finish for its intended purpose and each according to the material to which the hardware is being applied.
- B. Keying system will be determined by the Owner's Representative.

### PART 3 - EXECUTION

#### 3.01 INSTALLATION

- A. Install hardware in accordance with manufacturer's recommendations and instructions.

- B. Install hardware on UL labeled openings in accordance with manufacturer's requirements to maintain the fire rating.
- C. Mortise and cut to close tolerance and conceal evidence of cutting in the finished work.
- D. Remove, cover or protect hardware after fitting until paint or other finish is applied. Permanently install hardware after finishing operations are complete.
- E. Install closers on the room side of corridor doors, stair side of stairways, and interior side of exterior doors.
- F. Deliver one complete set of installation and adjustment instructions, and tools with the hardware.
- G. Coordinate security system electrical requirements at doors indicated to have such system.
- H. Coordinate all Owner Furnished Contractor Installed hardware.

3.02 ADJUSTING

- A. At final completion, adjust and test all hardware for function and performance and leave in good operating condition.

3.03 CLEANING

- A. Clean all hardware to restore the original finish.

3.04 PROTECTION

- A. Protect the finished installation until acceptance of the project.

3.05 HARDWARE SCHEDULE

- A. Manufacturers
  - 1. Hinges
 

	Hager Hinge Co.	HAG
a. Approved Equals:	Stanley McKinney	
  - 2. Lockset
 

	Best Access Systems	BES
a. Approved Equals:	Provide 7-pin cylinders to match existing. Coordinate with Best Access Systems for keying of project, No Substitutions. Best Access Systems is indicated in this specification as a basis of design, Marshall Best Security Corporation to accept Best Access System Core is an acceptable equal.	
  - 3. Door Closers
 

	Model 4010/4110	LCN
a. Approved Equals:	No Substitutions	
  - 4. Kickplate
 

	Rockwood Mfg. Co	ROC
--	------------------	-----
  - 5. Biometric Hand Readers
 

	Schlage Recognition Systems	SCH
--	-----------------------------	-----
  - 6. Electric Strikes
 

	Von Duprin	VON
a. Approved Equals:	HES Folger Adams	
  - 7. Door Position Switch
 

	SENTROL	LCK
--	---------	-----
  - 8. Clothes Hook
 

	Bobrick	BBK
--	---------	-----
- B. Hardware Sets:

**SET 1A**

EA	HINGES	BB1279	652 HAG
1 EA	PUSH PLATE	70C	630 ROC
1 EA	PULL w/PLATE	111 x 70C	630 ROC
1 EA	WALL STOP	WS407	630 IVE
1 EA	CLOSER	4010/4110	689 LCN
1 EA	KICKPLATE	10" x 1 1/2" LDW	630 IVE

**SET 2A**

EA	HINGES	BB1279 NRP	652 HAG
1 EA	STOREROOM LOCK	93K D x 14D	626 BES
1 EA	WALL STOP	WS407	630 IVE
1 EA	KICKPLATE	10" x 1 1/2" LDW	630 IVE

**SET 3A**

EA	HINGES	BB1191 NRP	630 HAG
1 EA	RIM EXIT DEVICE	99L-NL	626 VON
1 EA	CYLINDER	AS REQUIRED	626 BEST
1 EA	CLOSER	4110	689 LCN
1 EA	OVERHEAD STOP	100S	630 GJ
1 EA	THRESHOLD	410S	MIL HAG
1 EA	SWEEP	750SN	CLR HAG
1 SET	SEALS	891SV	MIL HAG
1 EA	ELECTRIC STRIKE	6300	630 VON

*EXISTING CARD READER TO BE REUSED*

END OF SECTION 08 71 00

SECTION 08 80 00

GLAZING

PART 1 - GENERAL

1.01 RELATED DOCUMENTS

- A. Conditions of the Contract and portions of Division One of this Project Manual apply to this Section as though repeated herein.

1.02 WORK INCLUDED

- A. Glass in Steel and Wood Doors
- B. Glass in Aluminum-Framed Entrances and Storefronts.
- C. All Glass Display Door

1.03 RELATED WORK

- A. Hollow Metal Doors and Frames: Section 08 11 13.
- B. Flush Wood Doors: Section 08 14 16.
- C. Aluminum-Framed Entrances and Storefronts: Section 08 41 13.

1.04 REFERENCES

- A. Reference Specification: "Glazing Manual", by Flat Glass Marketing Association.
- B. Materials: Conform in all respects to the "Safety Standard for Architectural Glazing Materials", 16CFR 1201, issued by the Consumer Product Safety Commission.
- C. AMERICAN ARCHITECTURAL MANUFACTURERS ASSOCIATION (AAMA)
  - 1. Aluminum Storefront and Entrance Manual.
  - 2. Structural Sealant Glazing Systems (A Design Guide) Aluminum CW Series No. 13.
- D. AMA WSG.1 Window Selection Guide.

1.05 QUALITY ASSURANCE

- A. Manufacturer Qualifications for Insulating-Glass Units with Sputter-Coated, Low-E Coatings: A qualified insulating-glass manufacturer who is approved and certified by coated-glass manufacturer.
- B. Installer Qualifications: A qualified installer who employs glass installers for this Project who are certified under the National Glass Association's Certified Glass Installer Program.
- C. Glazing Publications: Comply with published recommendations of glass product manufacturers and organizations below, unless more stringent requirements are indicated. Refer to these publications for glazing terms not otherwise defined in this Section or in referenced standards.
  - 1. GANA Publications: GANA's "Laminated Glazing Reference Manual" and GANA's "Glazing Manual."

- 1 2. IGMA Publication for Insulating Glass: SIGMA TM-3000, "North American Glazing  
2 Guidelines for Sealed Insulating Glass Units for Commercial and Residential Use."  
3
- 4 D. Safety Glazing Labeling: Where safety glazing labeling is indicated, permanently mark glazing  
5 with certification label of the SGCC or another certification agency acceptable to authorities  
6 having jurisdiction. Label shall indicate manufacturer's name, type of glass, thickness, and  
7 safety glazing standard with which glass complies.  
8
- 9 E. All materials used for this project shall be from the same batch run and manufacturer.  
10
- 11 F. Water Penetration Resistance, nor uncontrolled water leakage; tested as per ASTM E331  
12
- 13 G. Thermal Transmittance Resistance: Maximum "U" factor in accordance with Wisconsin Enrolled  
14 Commercial Code; as tested by AAMA 1503.1  
15
- 16 H. Condensation Resistance; Condensation Resistance Factor (CRF) to be minimum 56/frame and  
17 50/glass, with 30 percent inside relative humidity, and 68 degree F temperature.; as tested by  
18 AAMA 1530.1.  
19
- 20 I. Sound Transmission Resistance; Sound Transmission Class (STC) for typical application to be  
21 minimum of 32; AS tested by ASTM E4134.  
22
- 23 J. Fenestration must comply with a minimum testing performance requirements for an  
24 AAMA/NWWDA 101/1.S.2 HC-40 rating. The recognized standard for performance ratings of  
25 windows is AAMA/NWWDA 101/1.S.2.  
26
- 27 K. All performance testing must be conducted by an independent, impartial, third party, AAMA  
28 certified testing laboratory.  
29
- 30 L. Polyurethane thermal barriers shall be tested as per AAMA TIR A8-90 and AAMA Draft #13 of  
31 AAMA's Dry Shrinkage & Composite Performance Thermal Cycling Procedure for validation  
32 testing at differential temperatures. At the conclusion of the tests, the shrinkage shall be equal to  
33 or less than the prescribed 0.10%.  
34
- 35 M. Use of poured and de-bridged polyurethane thermal beak assemblies will require window  
36 manufacturer's prior adoption and continued use of the procedures and quality control features  
37 outlined in AAMA's Quality Assurance processing guide For Poured and De-bridged  
38 Polyurethane Thermal Barriers.  
39

40 1.06 PERFORMANCE REQUIREMENTS  
41

- 42 A. General: Installed glazing systems shall withstand normal thermal movement and wind and  
43 impact loads (where applicable) without failure, including loss or glass breakage attributable to  
44 the following: defective manufacture, fabrication, or installation; failure of sealants or gaskets to  
45 remain watertight and airtight; deterioration of glazing materials; or other defects in construction.  
46

47 1.07 INSULATED GLASS WARRANTY  
48

- 49 A. Provide insulating glass manufacturer's written guarantee as per Sections 08 41 13.  
50

51 1.08 SUBMITTALS  
52

- 53 A. Submit in accordance with the General Conditions of the Contract  
54 1. Manufacturer's product data.



- 1  
2 A. Float Glass: ASTM C 1036, Type I, Quality-Q3, Class 1 (clear) unless otherwise indicated.  
3  
4 B. Heat-Treated Float Glass: ASTM C 1048; Type I; Quality-Q3; Class I (clear) unless otherwise  
5 indicated; of kind and condition indicated.  
6 1. Fabrication Process: By horizontal (roller-hearth) process with roll-wave distortion  
7 parallel to bottom edge of glass as installed unless otherwise indicated and free of tong  
8 marks.  
9 2. For uncoated glass, comply with requirements for Condition A.  
10 3. For coated vision glass, comply with requirements for Condition C (other coated glass).  
11 4. Comply with requirements for safety glass in the International Building Code.  
12  
13 C. Uncoated Tinted Float Glass: Class 2, complying with other requirements specified.  
14

15 2.03 INSULATING GLASS  
16

- 17 A. Glass Type GLT-13: Low-E Clear + Clear insulating glass PPG Industries, Inc.; Solar Control, Low-  
18 E, Solarban 60:  
19 1. Overall Unit Thickness: 1 inch.  
20 2. Thickness of Each Glass Lite: 6.0 mm.  
21 3. Outdoor Lite: Clear float glass, heat-strengthened float glass or fully tempered float glass as  
22 required by conditions and codes.  
23 a. Outdoor lite: Clear Solarban 60 Low-E Coating: Sputtered on second surface.  
24 4. Interspace Content: Air.  
25 5. Indoor Lite: Clear float glass, heat-strengthened float glass or fully tempered float glass as  
26 required by conditions and codes.  
27  
28 6. Visible Light Transmittance: 70 percent minimum.  
29 7. Winter Nighttime U-Factor: 0.29 maximum.  
30 8. Summer Daytime U-Factor: 0.27 maximum.  
31 9. Solar Heat Gain Coefficient: 0.39 maximum.  
32 10. Shading Coefficient: 0.45  
33 11. Outdoor Visible Light Reflectance: 11 percent.  
34 12. Provide safety glazing labeling.  
35 13. Glass: Clear float.  
36  
37 B. Insulating-Glass Units: Factory-assembled units consisting of sealed lites of glass separated by a  
38 dehydrated interspace, qualified according to ASTM E 2190, and complying with other  
39 requirements specified.  
40 1. Sealing System: Dual seal, with manufacturer's standard primary and secondary.  
41 2. Spacer: Manufacturer's standard spacer material and construction.  
42 3. Desiccant: Molecular sieve or silica gel, or blend of both.  
43 4. Dehydrated Interspace Content: Air.  
44 5. Thickness: 1 inch typical; provide 5/8 inch thick unit at storefront entrance.  
45

46 2.04 GLASS TYPE SCHEDULE  
47

- 48 A. Glass Products indicated below are based on proprietary products of Viracon, PPG, SAFTI FIRST  
49 Serious Materials and Bendheim. Products from any of the above listed manufacturers that meet the  
50 design criteria of the glass specified below are acceptable.  
51 1. GLT 1: Clear float glass.  
52 a. Thickness: 1/4".  
53  
54 2. GLT 2: Tempered glass mirror.  
55 a. Thickness: 4.0mm.



- 1  
2 3. GLT 4: Tempered, clear float glass.  
3 a. Thickness: 1/4".  
4  
5 4. GLT 13: Refer to above.  
6  
7 2.05 3ALL GLASS DISPLAY DOORS  
8  
9 1. Blumcraft 1301-SM Display Case Doors or approved equal  
10 a. Tempered clear float glass, 3/8" thick  
11 b. 1 1/4" square top and bottom frame  
12 c. Satin clear anodized  
13 d. AP-150 Top Pivot  
14 e. 7150 Lever type cam lock  
15 f. BP-150 Bottom Pivot  
16 g. Provide all hardware, locking components and fasteners for a complete installation.  
17  
18 2.06 GLASS SHELF AND BRACKETS  
19  
20 1. Tempered clear float glass, 3/8" thick  
21 2. C.R. Laurence Co., Inc. CRL Adjustable Shelf Brackets DL631, satin chrome finish.  
22  
23 2.07 GLAZING ACCESSORIES  
24  
25 A. Glazing Sealant: One-part silicone similar to Pecora 860, Sonneborn Omniplus or Tremco  
26 Spectrum 2.  
27 1. Comparable means both quality and color options.  
28  
29 B. Setting Blocks: 70-90 Shore "A" durometer, sized to accommodate size of glass used, compatible  
30 with glazing sealant.  
31  
32 C. Spacers: Compatible with sealant used.  
33  
34 D. Primer, Sealers, Cleaners for Fire-Rated Glazing: As recommended by fire-rated glazing  
35 manufacturer.  
36  
37  
38 PART 3 - EXECUTION  
39  
40 3.01 EXAMINATION  
41  
42 A. Check that glazing channels are free of burrs, irregularities, and debris.  
43  
44 B. Check that glass is free of edge damage or face imperfections.  
45  
46 C. Do not proceed with installation until conditions are satisfactory.  
47  
48 3.02 PREPARATION  
49  
50 A. Field Measurement  
51 1. Measure size of frame to receive glass.  
52 2. Compute actual glass size, allowing for edge clearances.  
53  
54 B. Preparation of Surfaces  
55 1. Remove protective coatings from surfaces to be glazed.



## SECTION 09 29 00

### GYPSUM BOARD

#### PART 1 - GENERAL

##### 1.01 RELATED DOCUMENTS

- A. Conditions of the Contract and portions of Division One of this Project Manual apply to this Section as though repeated herein.

##### 1.02 WORK INCLUDED

- A. Metal Studs.
- B. Gypsum Board.
- C. Trim and Accessories.
- D. Acoustical Batt Insulation.

##### 1.03 RELATED WORK

- A. Section 09 90 00 Painting.

##### 1.04 REFERENCES

- A. Referenced Specifications: The more stringent requirement of this section or referenced specification applies.
  - 1. "Using Gypsum Board for Walls and Ceilings", The Gypsum Association - GA-201-85.
  - 2. "Recommended Specifications for the Application and Finishing Gypsum Boards", The Gypsum Association - GA-216.

##### 1.05 SUBMITTALS

- A. Submit in accordance with the General Conditions of the Contract.
  - 1. Manufacturer's product data.
  - 2. Texture finish sample.

##### 1.06 DELIVERY, STORAGE AND HANDLING

- A. Deliver materials to the project site with manufacturer's labels intact and legible.
- B. Handle materials with care to prevent damage.
- C. Deliver fire-rated material bearing testing agency label and required fire classification numbers.
- D. Storage
  - 1. Store materials inside under cover, stack flat, off floor.
  - 2. Stack wallboard so that long lengths are not over short lengths.
  - 3. Avoid overloading floor system.
  - 4. Store adhesives in dry area, provide protection against freezing at all times.

##### 1.07 PROJECT CONDITIONS

- A. During cold weather, maintain temperature range between 55 degrees F. to 70 degrees F. for 24 hours before, during, and after gypsum board and joint treatment applications.
- B. Ventilation
  - 1. Provide ventilation during and following adhesive and joint treatment applications.
  - 2. Use temporary air circulators in enclosed areas lacking natural ventilation.
  - 3. Protect installed materials from drafts during hot, dry weather.

## PART 2 - PRODUCTS

### 2.01 MANUFACTURERS

- A. Georgia Pacific.
- B. LaFarge.
- C. National Gypsum Company, Gold Bond.
- D. United States Gypsum Company.
- E. BPB America, Inc.
- F. Chicago Metallic.
- G. Dietrich Industries.
- H. Or approved equal.

### 2.02 MATERIALS

- A. Gypsum Board: ASTM C 36, long edges tapered; in lengths as long as practical to keep number of end joints to absolute minimum.
  - 1. Regular Gypsum Board.
  - 2. Water Resistant Wallboard: 5/8-inch thick.
  - 3. Cementitious Backer Board: Aggregated, Portland cement board with woven, glass fiber, mesh facing; complying with ANSI A118.9.
    - a. Manufacturer: USG, Durock Interior Tile Backer Board or approved equal.
    - b. Thickness: 1/2 inch.
  - 4. Veneer Plaster Base: USG Imperial Gypsum Base, 5/8-inch thick.
  - 5. Fire Rated 1 Inch thick gypsum wall board panels, supplied in nominal 24 inch widths type SLX.
  - 6. Fire Rated Face Layer: 5/8 inch Gypsum Board:
    - a. American Gypsum; Types AGX-1, AG-C
    - b. Certainteed Gypsum; ProRoc Type C
    - c. Georgia Pacific Gypsum; Type S
    - d. USG; Type C, FRX-G, IP-X2, IPC-AR, SCX, or WRC.
    - e. Or approved equal.
- B. Accessories
  - 1. Metal Trim: USG No. 200-A.
  - 2. L-shaped Metal Trim for Veneer Plaster: USG No. 801-B.
  - 3. Metal Reveal Molding: Fry Reglet DRM-625-75.
  - 4. Metal 'Z' Reveal Molding, 1/4" wide: Fry Reglet DRMZ-625-25.

5. Metal 'Z' Reveal Molding, 1" wide: Fry Reglet DRMZ-100-100.
  6. Expansion Joints: USG No. 093.
  7. Drywall Screws for Metal Framing: 1" Type S-12 or Type S bugle head.
  8. Outside Corner Reinforcement: USG No. 104, 1-1/8" x 1-1/8" corner bead.
  9. Acoustical Sealant: Equal to Tremco "Tremflex 834" or Pecora "Acoustic and Insulation Sealant", low VOC formulation.
    - a. VOC content less than 50 g/l.
  10. Tie Wire: No. 18 SWG, steel wire.
  11. Steel runner channel brackets: 25 MSG galvanized steel.
  12. Corner angles: 25 MSG galvanized steel.
  13. Sound Attenuation Blanket: U.S. Gypsum Thermafiber, or approved equal, 3" for an STC of 49.
- C. Metal Studs/Resilient Furring Channels.
1. Unless indicated otherwise, use 25-gage for partitions up to 12'-0" high, use 20-gage for partitions over 12'-0" high.
  2. Unless indicated otherwise, use 20-gage studs at door jambs, head.
  3. Track gauge shall be same gauge as nested studs.
  4. 2 ½ inch wide by 1 ½ inches deep C-H studs 24 inch on center. Fabricated from minimum 25 MSG galvanized steel.
- D. Suspension System
1. Chicago Metallic 640 system
    - a. Hanger Wire: 8-gage, annealed.
    - b. Carrying Channels: 1-1/2 inch cold rolled steel.
    - c. Screws: USG 1-inch type S.
    - d. Furring Channels: USG metal furring channel, attached with USG furring channel clips.
  2. Chicago Metallic 650 System complying with UL Design No. D502.
    - a. Hanger clips: 18 gauge galvanized steel.
    - b. Hanger wire: No. 12 SWG galvanized steel.
    - c. Carrying Channels: 16 gauge 1 ½ inch cold rolled.
    - d. Furring Cross Channel: 16 gauge 7/8 inch where required.
    - e. Wall Molding: 26 gauge steel channel 1 11/16 inch deep with 15/16 inch flanges.
  3. Or approved equal.
- E. Drywall Finishing Accessories
1. Joint Compounds: Ready mixed type.
  2. Joint Reinforcement: USG Perf-A-Tape or approved equivalent.
- F. Texture Finish Materials
1. Ceilings: USG Spray Fine Sand Texture Finish or approved equal.
  2. Walls (Painted Only): USG Spray Fine Sand Texture Finish, or approved equal.
    - a. To match existing, adjacent plaster texture.

## PART 3 - EXECUTION

### 3.01 GYPSUM BOARD

- A. Follow Gypsum Association's recommendations for installation procedures.
- B. Cut wallboards by scoring and breaking or sawing; scribe neatly at wall projections.
- C. Apply first to ceilings then to walls.

- D. Locate wallboard joints at openings so that no end joint aligns with edge of opening.
- E. Set fasteners with heads slightly below surface of wallboard. Avoid breaking face paper.
- F. Provide water resistant wallboard at rooms/areas with high humidity.

### 3.02 METAL STUDS

- A. Attach metal runners at floor and at ceiling or structural elements above with suitable fasteners located 2 inches from each end, spaced 16 inches on center.
- B. Position studs vertically, engaging floor and ceiling runners. Splice studs with 8-inch nested lap, one positive attachment per stud flange. Place studs in direct contact with all door frame jambs, abutting partitions, partition corners, existing construction elements.
- C. Provide double studs at jambs and head of each door frame. Securely anchor studs to jamb and head anchor clips at metal door frames by bolt or screw attachment. Over metal frames, place a cut-to-length section of runner horizontally with web-flange bent at each end; secure with one positive attachment per flange. Position a cut-to length stud (extend to ceiling runner) at vertical board joints over door frame header. Place an additional track-to-track stud 6 inches from double jamb studs on both sides of framed openings.
- D. At curved surfaces, space studs and framing members 8 inches on center maximum.

### 3.03 CEILING SUSPENSION SYSTEM

- A. Suspend carrying channels with 8-gage hanger wires spaced 48 inches on center, within 6 inches of ends.
- B. Install carrying channels 48 inches on center and within 6 inches of walls. Provide 1 inch clearance between channel ends and abutting walls, partitions.
- C. At splices, interlock flanges, overlap ends 12 inches, and secure with 16-gage double standard tie wire at each end.
- D. Erect furring channels at right angles to carrying channels, spaced 24 inches on center and within 6 inches of walls. Provide 1-inch clearance between channel ends and abutting walls, partitions.
- E. Secure to carrying channels with clips, or, saddle tie with 16-gage double standard tie wire. At splices nest channels at least 8 inches, securely wire tie at each end.
- F. Install additional cross reinforcing to restore lateral stability of suspension system at openings that interrupt carrying or furring channels.
- G. Apply wallboard of maximum practical length with long dimension at right angles to furring channels. Position and stagger end joints over channel web. Fit ends and edges closely, but not forced together.
- H. Fasten board to channels with 1-inch Type S screws spaced 12 inches on center in field of board, along abutting ends, edges.

### 3.04 EXPANSION JOINTS

- A. At Ceilings: 50'-0" on center each way maximum.
- B. At Walls: 30'-0" on center maximum.

- C. Provide at intersections with exposed masonry construction.

### 3.05 SINGLE LAYER/ERECTION

- A. Position all ends, edges over framing members, except when edge joints are at right angles to framing members, or when end joints are back-blocked. Apply wallboard horizontally or vertically on walls to minimize the number of joints.
- B. Attach wallboard to metal framing supports by power driven screws. For vertical application space screws 12 inches on center in field of board, 8 inches on center staggered along vertical abutting edges. For horizontal application space screws 12 inches on center in field, along abutting end joints.

### 3.06 MULTI-LAYER WALLBOARD ERECTION

- A. Base Layer: Erected as specified for "Single Layer Erection".
- B. Joints in face layer to fall at least 10 inches from parallel joints in base layer.
- C. Apply face layers with adhesive in accordance with wallboard manufacturer's printed instructions. Provide sufficient number and spacing of fasteners to hold top layer tight with bottom layer until adhesive dries.

### 3.07 JOINT TREATMENT APPLICATION

- A. Mix joint compound in accordance with manufacturer's recommendations.
- B. Apply compound in thin uniform layer to all joints, angles to be reinforced. Apply reinforcing tape centered over joint, seated into compound. Follow immediately with thin skim coat or embed tape. Fold and embed tape in interior angles to provide true angle.
- C. When embedding coat is thoroughly dry, apply second coat of compound, filling board taper flush with surface. Cover tape, feather out slightly beyond tape.
- D. On joints with no taper, cover tape, feather out at least 4 inches on either side of tape.
- E. No second coat is required on interior angles.
- F. When second coat is thoroughly dry, spread finish coat evenly over and extend slightly beyond second coat. Feather to a smooth, uniform finish.
- G. Over taped edges, do not allow finish coat to protrude beyond plane of surface. Apply finish coat to cover tape, taping compound at taped angles to provide true angle. When necessary, sand between coats and follow with final coat to provide smooth surface ready for decoration.
- H. Do not abrade adjacent face-paper surfaces.
- I. Gypsum substrate where located behind dry erase wallcoverings must meet level 4 requirements: All joints and interior angles have tape embedded in joint compound and two separate coats of joint compound applied over all flat joints and one separate coat of joint compound applied over interior angles. Fastener heads and accessories shall be covered with three separate coats of joint compound. All joint compound shall be smooth and free from tool marks and ridges.

### 3.08 FINISHING FASTENERS

- A. Apply compound to fastener depressions. Follow with minimum of two additional coats leaving depressions level with surface.
- B. Do not abrade adjacent face-paper surfaces.

3.09 FINISHING BEAD AND TRIM

- A. Apply first coat to beads, trim. Properly feather out from ground to plane of surface. Embed flanges of corner reinforcement with compound.
- B. When embedding coat is thoroughly dry, apply second coat in same manner as first-coat, extending compound slightly beyond onto face of board.
- C. When second coat is thoroughly dry, apply finish coat extending compound slightly beyond second coat, properly feathering from ground to plane of surface. Sand finish coat as necessary to provide a level 4 flat smooth surface, ready for decoration. See specification section 09 72 00, Wall Coverings and provide surface required by manufacturer's recommendation.
- D. Do not abrade adjacent face-paper surfaces.

3.010 ACOUSTIC SEALANT

- A. Apply sealant at intersections of wallboard and adjacent materials to form a complete seal to air and noise.

3.011 TEXTURE FINISH

- A. Apply texture finish in accord with manufacturer's printed instructions.
- B. Provide uniform texture over entire surface.

3.012 ADJUST AND CLEAN

- A. Ridging
  1. Sand ridges to reinforcing tape without cutting through tape.
  2. Fill concave areas on both sides of ridge with topping compound.
  3. After fill is dry, blend in topping compound over repaired area.
- B. Fill cracks with compound and finish smooth and flush.

END OF SECTION 09 29 00



SECTION 09 30 00

TILING

PART 1 - GENERAL

1.01 RELATED DOCUMENTS

- A. Conditions of the Contract and portions of Division One of this Project Manual apply to this Section as though repeated herein.

1.02 WORK INCLUDED

A. Wall Tile

B. Floor Tile

C. Base Tile

D. Transition Strips

1.03 RELATED WORK

- A. Gypsum Board, Section 09 29 00.

1.04 REFERENCES

- A. The following specifications and standards are incorporated by reference:  
1. Tile Council of America, Inc. - "Handbook for Ceramic Tile Installation".

1.05 SUBMITTALS

- A. Submit in accordance with the General Conditions of the Contract.  
1. Samples for colors on 12 inch by 12 inch panels in duplicate for tile specified.  
2. Samples in duplicate for each different trim piece required.  
3. Grout samples in duplicate indicating color range anticipated, texture.

1.06 DELIVERY, STORAGE, AND HANDLING

- A. Package, handle, deliver and store at the job site in original unbroken containers in a manner that will avoid damage or contamination.

B. All containers shall bear grade seals, manufacturer's name, size, color and quantities.

1.07 PROJECT CONDITIONS

- A. Set and grout tile when ambient temperature is at least 50 degrees F. and rising.

1.08 EXTRA MATERIALS

- A. Deliver stock of extra materials to Owner. Furnish extra materials from same manufactured lot as materials installed and enclosed in protective packaging with appropriate identifying labels.  
1. Furnish one box for each type, color, pattern and size installed.

1 PART 2 - PRODUCTS

2  
3 2.01 TILE

4  
5 A. Wall tile.

6 1. WT-1: Porcelain Tile

- 7 a. Dal-Tile Colorbody Imagica  
8 b. Color: Cosmo Unpolished  
9 c. Sizes: 4"x48", 6"x48" and 8"x48"  
10 d. Installation: Random staggered brickwork pattern.

11  
12 B. Wall tile.

13 1. WT-2: Porcelain Tile

- 14 a. United States Ceramic Tile Color Collection  
15 b. Color: to be selected from manufacture's full range of Color Group 1.  
16 c. 3"x 6"

17  
18 C. Floor tile.

19 1. FT-1: Porcelain Tile

- 20 a. Dal-Tile Colorbody Imagica  
21 b. Color: Cosmo Unpolished  
22 c. Sizes 4"x48", 6"x48" and 8"x48"  
23 d. Installation: Random staggered brickwork pattern.

24  
25 D. Base tile.

26 1. BT-1: Porcelain Tile

- 27 a. Dal-Tile Colorbody Imagica  
28 b. Color: Cosmo Unpolished  
29 c. Size: 4"

30  
31 E. Dal-Tile or United States Ceramic Tile are used as the basis of design. Approved equal by Atlas Concorde,  
32 Ceasar Ceramics USA or approved equal.

33  
34 2.02 SETTING MATERIALS

35  
36 A. Latex-Portland Cement Mortar (Thin Set): ANSI A118.4, consisting of the following:

- 37 1. Prepackaged dry-mortar mix containing dry, re-dispersible, ethylene vinyl acetate additive to which  
38 only water must be added at Project site.  
39 2. Prepackaged dry-mortar mix combined with acrylic resin liquid-latex additive.  
40 a. For wall applications, provide non-sagging mortar that complies with Paragraph F-4.6.1 in  
41 addition to the other requirements in ANSI A118.4.

42  
43 2.03 ACCESSORIES

44  
45 A. Portland Cement: ASTM C 150, type 1.

46  
47 B. Sand: ASTM C-144.

48  
49 C. Water: Clean and potable.

50  
51 D. Tile Cleaner: A neutral cleaner capable of removing soil and residue without harming tile and grout surfaces,  
52 specifically approved for materials and installations indicated by tile and grout manufacturers.

53  
54 E. Grout:

- 1  
2 1. Selection to meet per tile manufacturer's recommendation.  
3 a. Bostik "Hydroment Vivid" premium grade, stain resistant cementitious grout or approved  
4 equal.  
5 b. Color: To be selected by AE from manufacturer's full range of colors.  
6  
7 F. Trowelable Underlayments and Patching Compounds: Latex-modified, portland cement-based formulation  
8 provided or approved by manufacturer of tile-setting materials for installations indicated.  
9  
10 G. Provide other materials not specifically described but required for a complete and proper installation. Provide  
11 Schluter Schiene at cut tile edges. Review on site with architect.  
12  
13 H. Transition Strips:  
14  
15 1. Tile to sealed concrete  
16 a. Manufacturer: Schluter  
17 b. Profile: Schluter Schiene and Reno-V  
18 c. Material: Aluminum  
19 d. Size according to materials used with approval of A/E.  
20  
21 2. Or approved equal.  
22

23 PART 3 - EXECUTION

24  
25 3.01 EXAMINATION

- 26  
27 A. Examine surfaces where tile is to be applied and notify the Contractor of any defects.  
28

29 3.02 INSTALLATION

30  
31 A. General

- 32 1. Provide all proper installation methods for freezing climate.  
33 2. Installation and workmanship shall be in accordance with ANSI A108.1 and as specified herein. The  
34 printed instructions of the tile manufacturer and the manufacturer of proprietary mortars and grouts  
35 shall be followed where applicable.  
36 3. Before commencing work, establish field pattern and border line locations.  
37 4. Center the work symmetrically so that no tile need be cut to less than half size.  
38 5. Joints in wall tile shall be aligned vertically and horizontally; staggered joints will not be accepted.  
39 6. Align joints when adjoining tiles on floor, base and trim are the same size.  
40 7. Rub exposed edges smooth.  
41

- 42 B. Interior Wall Tile Setting Bed: TCA W202/Tile backer board substrates - acrylic modified latex-cement  
43 mortar.  
44

- 45 C. Handle, store, mix and apply proprietary setting and grouting materials in compliance with the manufacturer's  
46 instructions.  
47

- 48 D. Extend tile work into recesses and under equipment and fixtures to form a complete covering without  
49 interruptions, except as otherwise shown.  
50

- 51 E. Terminate work neatly at obstructions, edges, and corners without disruption of pattern or joint alignments.  
52

- 53 F. Comply with manufacturer's instructions for mixing and installation of proprietary materials.  
54

- 1 G. Neutralize and seal substrates in accordance with setting bed manufacturer's instructions, where required.  
2  
3 H. Jointing Pattern: Grid pattern.  
4  
5 I. Expansion, Control Joints  
6 1. Extend completely through tile mortar bed. Insert preformed back-up material to provide correct  
7 cavity depth for sealant.  
8 2. Width of expansion, control joints: Same as tile joints.  
9 3. Prior to grouting, keep expansion and control joints open and clean.  
10 4. After tile is grouted and completely dry, remove temporary filler material. Brush joints clean, fill  
11 expansion and control joints.  
12  
13 J. Seal as per manufacturers requirements.  
14  
15 3.03 CLEANING  
16  
17 A. After completion, clean all work, point open joints and replace defective work.  
18  
19 3.04 PROTECTION  
20  
21 A. Close off work spaces to traffic during installation and at least 48 hours after completion of work.  
22  
23 B. Tiled vertical outside corners shall be protected with board corner strips in areas used as passageways.  
24  
25

26 END OF SECTION 09 30 00  
27

SECTION 09 51 00  
ACOUSTICAL CEILINGS

PART 1 - GENERAL

1.01 RELATED DOCUMENTS

- A. Conditions of the Contract and portions of Division One of this Project Manual apply to this Section as though repeated herein.

1.02 WORK INCLUDED

- A. Acoustical Board.
- B. Suspension Systems.

1.03 RELATED WORK

- A. Fire Suppression: Division 21.
- B. Heating, Ventilating and Air Conditioning: Division 23.
- C. Electrical: Division 26.

1.04 SUBMITTALS

- A. Submit in accord with the General Conditions of the Contract.
  - 1. Manufacturer's product specifications and installation instructions for each acoustical ceiling material and suspension system required, including certified laboratory test reports.

1.05 DELIVERY, STORAGE AND HANDLING

- A. Deliver materials in original, unopened, protective packaging, with manufacturer's labels indicating brand name, pattern, size and thickness as applicable, legible and intact.
- B. Store materials in original protective packaging to prevent soiling, physical damage or wetting.
- C. Store cartons open at each end to stabilize moisture content and temperature.

1.06 PROJECT CONDITIONS

- A. Do not install interior acoustical ceilings until space is enclosed and weatherproof. Complete installation of damp materials before beginning work.
- B. Maintain humidity of 65 - 75 percent in areas where acoustical materials are to be installed 24 hours before, during, and after installation.
- C. Maintain a uniform temperature in the range of 55 to 70 degrees F. prior to and during installation of materials.

1.07 EXTRA MATERIALS

- A. In accord with General Conditions of the Contract, deliver extra materials equal to a minimum of 50 square feet of each type of acoustical material supplied.
- B. All cartons shall be new, unopened, packaged with protective covering for storage, and identified with appropriate labels.

## PART 2 - PRODUCTS

### 2.01 BOARD TYPE 1

- A. Lightly textured nodular lay-in panels, 3/4" thick x 2' x 2', Reveal edge (tegular), White. UL Classified Noise Reduction Coefficient (NRC) .60, Ceiling Attenuation Class (CAC) 35, Light Reflection Coefficient .82, "BioShield", 15 year warranty against sag, 82% recycled content.
- B. Celotex Brand, "Cashmere".
- C. Or approved equal by Armstrong World Industries, Ecophon Certainteed, or USG.

### 2.03 INTERMEDIATE DUTY SUSPENSION SYSTEM TYPE 1

- A. Armstrong, "Prelude ML, 15/16" Exposed Tee".
  - 1. Material: Hot-dipped, galvanized steel.
  - 2. Surface Finish: Baked polyester paint.
- B. Or approved equal by Chicago Metallic, National Rolling Mills, Donn/USG.
- E. Conform to all requirements of ASTM C-635 intermediate structural classification.
- F. Provide flat white finish, 15/16" face.

## PART 3 - EXECUTION

### 3.01 EXAMINATION

- A. Examine surfaces scheduled to receive suspended or directly attached acoustical units for unevenness, irregularities, and dampness that would affect quality and execution of work. Do not proceed with work until unsatisfactory conditions have been corrected.

### 3.02 INSTALLATION

- A. Do not begin installation until sufficient materials to complete a room are received.
- B. Install materials in accordance with manufacturer's printed instructions, governing regulations, fire resistance rating requirements, and industry standards applicable to work.
- C. Measure each ceiling area and establish layout of acoustical units to balance border widths at opposite edges of each ceiling. Avoid use of less-than-half width units at borders, and comply with reflected ceiling plans wherever possible.
- D. Symmetrically locate grid layout in each space. Coordinate work with other trades so that lighting fixtures, grilles, and other ceiling fixtures work with grid layout.

- E. Do not use universal splices or other splices which would obstruct passage of recessed lighting fixtures through grid openings or limit fixture relocation upon flanges of ceiling grids.
- F. Support suspension system from structure above, not from ductwork, metal deck, equipment or piping.
- G. Space hangers not more than 6 inches from ends and not more than 4 feet on center.
- H. Install edge moldings at the perimeter of each acoustical ceiling area and at locations where edge of units would otherwise be exposed.
  - 1. Secure moldings to building construction by fastening with screw anchors into the substrate, through holes drilled in vertical leg. Space holes not more than 3 inches from each end and not more than 16 inches on center along each molding.
  - 2. Level moldings with ceiling suspension system, to a level tolerance of 1/8 inch in 12 feet.
  - 3. Miter corners of moldings accurately to provide hairline joints, securely connected to prevent dislocation. Cope exposed flanges of intersecting suspension system members, so that flange faces will be flush.
  - 4. Furnish additional tees for supporting grilles, diffusers and light fixtures. Refer to the reflected ceiling, HVAC and electrical plans for locations.
  - 5. Provide tegular edge at walls, other abutting vertical surfaces.
  - 6. Field paint cut edges to match surface color and sheen.
- I. Arrange acoustical units and orient directionally-patterned units, if any, in manner shown on reflected ceiling plans.

### 3.03 CLEANING

- A. Clean exposed surfaces of acoustical ceilings, trim, edge moldings, and suspension members to comply with manufacturer's instructions for cleaning and touch-up of minor finish damage.
- B. Remove work which cannot be successfully cleaned and repaired to permanently eliminate evidence of damage.

### 3.04 PROTECTION

- A. Provide required protection for the acoustical ceilings, including temperature, humidity limitations and dust control so that the work will be without damage and deterioration at the time of acceptance by the Owner.

END OF SECTION 09 51 00

Page Intentionally Left Blank



## SECTION 09 65 00

### RESILIENT FLOORING

#### PART 1 - GENERAL

##### 1.01 RELATED DOCUMENTS

- A. Conditions of the Contract and portions of Division One of this Project Manual apply to this Section as though repeated herein.

##### 1.02 WORK INCLUDED

- A. Resilient Base.
- B. Resilient Flooring.
- C. Accessories.
- D. Subfloor Preparation.

##### 1.03 RELATED WORK

- A. Selective Structure Demolition: Section 02 41 19.

##### 1.04 QUALITY ASSURANCE

- A. Provide each type of resilient flooring and accessories from a single manufacturer, including recommended primers, adhesives, sealants, and leveling compounds.
- B. Installers Qualifications: Installer experienced (minimum of 2 years) to perform work of this section who has specialized in the installation of work similar to that required for this project and who is acceptable to the product manufacturer.
- C. Materials: For each type of material required for the work of this Section, provide primary materials which are the products of one manufacturer. Provide secondary materials which are acceptable to the manufacturer of the primary materials.
  - 1. Comply with applicable regulations regarding VOC (volatile organic compound) content of adhesives.

##### 1.05 SUBMITTALS

- A. Submit in accordance with the General Conditions of the Contract.
  - 1. Manufacturer's technical data for each type of resilient flooring and accessory.
    - a. Data indicating adhesive and accessories meet VOC requirements.
  - 2. Manufacturer's standard color charts in form of actual sections of resilient flooring, including accessories, showing full range of colors and patterns available, for each type of resilient flooring required.
  - 3. Submit samples of metal edge strips.
  - 4. Two copies of manufacturer's recommended maintenance practices for each type of resilient flooring and accessory required.

##### 1.06 DELIVERY, STORAGE AND HANDLING

- A. Deliver materials to project site in manufacturer's original, unopened containers with labels indicating brand names, colors and patterns, and quality designations legible and intact.
- B. Store and protect materials in accordance with manufacturer's recommendations.

#### 1.07 PROJECT CONDITIONS

- A. Maintain minimum temperature of 65 degrees F and maximum temperature of 90 degrees F in spaces to receive resilient flooring for at least 48 hours prior to installation, during installation, and for not less than 48 hours after installation. Subsequently, maintain minimum temperature of 55 degrees F in areas where work is completed.
- B. Store resilient flooring materials in spaces where they will be installed for at least 48 hours before beginning installation.
- C. Install resilient flooring and accessories after other finishing operations, including painting, have been completed.
- D. Do not install resilient flooring over concrete slabs until they have been cured and are sufficiently dry to achieve bond with adhesive as determined by resilient flooring manufacturer's recommended bond and moisture test.
- E. Close areas to traffic and to other work until flooring is firmly set. Tile shall have 72 hours with no traffic.
- F. Where solvent based adhesives are used, provide safety sparkproof fans when natural ventilation is not adequate.

#### 1.08 WARRANTY

- A. Provide current, detailed manufacturer's warranty for each flooring product as applicable including limited wear, defect and conductivity.
- B. Provide manufacturer's standard one-year warranty against defects in manufacturing and workmanship of resilient flooring products. Provide manufacturer's standard limited wear warranty/conductivity warranty as specified under each product as applicable.

#### 1.09 EXTRA MATERIALS

- A. Deliver stock of extra materials to Owner. Furnish extra materials from same manufactured lot as materials installed and enclosed in protective packaging with appropriate identifying labels.
  - 1. Furnish one box for each type, color, pattern and size installed.

#### 1.010 ENVIRONMENTAL REQUIREMENTS

- A. Low-Emitting Materials, Adhesives, and Sealants: Materials used on the interior of the building (defined as inside the weatherproofing system and applied on site) must not exceed the following requirements.
  - 1. Adhesives, Sealants and Sealant Primers: South Coast Air Quality Management (SCAQMD) Rule # 1168, requirements in effect on July 1, 2005, and rule amendment date January 7, 2005.
  - 2. Aerosol Adhesives: Green Seal Standard for Commercial Adhesives GS-36, requirements in effect on October 19, 2000.

### PART 2 - PRODUCTS

#### 2.01 RESILIENT FLOOR

- A. Johnsonite is used as the basis of design. Armstrong, or approved equal.
- B. RF-1 Product:
  - 1. Style Name/Number: Grain + Pigment
  - 2. Color: to be selected from manufacturer's full range. See installation pattern note below.
  - 3. Construction: High Performance Luxury Vinyl Tile.
  - 4. Direct glue down
  - 5. Overall Thickness: 2.5mm.
  - 6. 20 mil wear layer.
  - 7. Nominal Dimensions: 7"x48"
  - 8. 10 year limited commercial wear warranty and 10 year under bed warranty.
  - 9. Class III printed film vinyl plank
  - 10. Added antimicrobial: Flor Sept™
  - 11. Finish: ExoGuard™
  - 12. Backing Class: Commercial Grade.
  - 13. Slip Resistance/ASTM D2047: >0.65 (wet/dry).
  - 14. Static Load Limit/(Modified ASTM F970: 1500 psi.
  - 15. Passes ASTM F1914 Residual Indentation <8%
  - 16. Passes ASTM F137 Flexibility
  - 17. Passes ASTM G21 0: Fungi free.
  - 18. Passes ASTM F 1514 Resistance to Heat.
  - 19. Passes ASTM F 1515 Resistance to Light.
  - 20. Passes ASTM F 925 Resistance to Chemicals.
  - 21. Passes ASTM 648, Radiant Flux, > 0.45 watts/cm<sup>2</sup> NFPA Class 1
  - 22. Passes ASTM E662, Smoke Density, < 450.
- C. Installation pattern to be provided by Architect with a pattern containing (4) materials/colors. Random, graduated color pattern.

## 2.02 RESILIENT WALL BASE

- A. General: Rubber, cove base, top set, roll stock.
  - 1. Height: 4".
  - 2. Color RB-1: To be selected by architect from manufacturer's full range.
  - 3. Color RB-2: Match existing in open office.
- B. Manufacturers: Armstrong (colors to be selected from manufacturers' full range) or approved equal by:
  - 1. Flexco.
  - 2. Freudenberg Building Systems, Nora.
  - 3. Johnsonite.
  - 4. Roppe.

## 2.03 ACCESSORIES

- A. Adhesives: As recommended by Johnsonite to meet site conditions.
  - 1. Rubber Floor Tile
    - a. Johnsonite #965 Flooring and Tread Adhesive
    - b. Johnsonite #975 Two-Part Urethane Adhesive
    - c. Johnsonite #996 Two-Part Epoxy Adhesive
    - d. Refer to manufacturer's installation instructions
- B. Adhesive for Wall Base: W.W. Henry "595 Cove Base Adhesive", zero-VOCs; W.F. Taylor "2035 Cove Base Adhesive" or "2040 Premium Cove Base Adhesive", GreenGuard certified; PL Adhesives & Sealants "Cove Base Adhesive"; Bostik Findley, Durabond "D-740 Multipurpose Wall Adhesive".

1. Low-VOC type: VOC content less than 100 g/l.
- C. Concrete Slab Primer: Non-staining, low-VOC type, equal to W.F. Taylor Co. "Envirotec Healthguard" #2006, as approved by flooring and underlayment manufacturers.
  - D. Patching, Leveling, Underlayments: The leveling materials must be portland cement based and provide a minimum 3,500 PSI compressive strength (ASTM C 109) and sufficient bond to existing subfloor surface.
    1. Ardex, Laticrete, Duralox, Mapei, or equivalent, approved by flooring manufacturer.
    2. Trowelable Leveling and Patching Compounds: Latex-modified, Portland cement based or blended hydraulic-cement-based formulation as recommended by flooring manufacturer.
  - E. Metal Edge Strip: Similar to Ceramic Tile Company CTC1132CTA.
  - F. Transitional Mouldings where metal is not feasible:
    1. Carpet to Resilient Floor:
      - a. Johnsonite Adapter, CTA-XX-A or approved equal.
        - 1) Length: 12-feet.
        - 2) Color to be selected from Manufacturer's full range of colors.

## PART 3 - EXECUTION

### 3.01 EXAMINATION

- A. The subfloor must be prepped to meet meets the requirements as described in the manufacturer's installation instructions.
  1. Rough up smooth epoxy surfaces to accommodate resilient flooring manufacturer's installation requirements.
- B. A clean non-burnished concrete surface free from any paint, wax, oil, grease, and film forming curing compounds, silicate penetrating curing compounds, sealing, hardening or parting compounds is required. The surface should not have any alkaline salts, laitance, mold, mildew, residual adhesive, chemical adhesive removers or anything that may prevent appropriate products bonding to it. If not then the general contractor should provide the mechanical means to remove them. This could be dustless diamond grinding (DiamaBrush), bead-blast or similar with a suitable HEPA vacuum attachment. Review and comply with all relevant local, state and federal regulations.
- C. Clean out and fill or repair any dormant saw cuts and cracks with an appropriate product following the manufacturers written usage instructions. For any expansion (moving) joints, use an industry standard expansion joint assembly.
- D. When required, use a leveler following the manufacturers written instructions. The surface should be free of dust, solvents, paint, wax, varnish, oil, grease, asphalt, old adhesives, and other extraneous materials that may interfere with the bond. These should be completely removed by mechanical means only. Dustless diamond grinding or bead blasting are the preferred method to remove contaminates and bond breakers, as it also helps to level the concrete.
- E. Perform mat bond tests in each major area (1 per ~1,000 sq. ft.) This should consist of the proposed subfloor preparation, mitigation and leveling or smoothing products. Do not proceed with installation until all the results of the bond test are acceptable.
- F. Prime the subfloor prior to using a suitable leveler, as approved by the resilient flooring manufacturer.

- G. Vacuum floors immediately prior to installing the flooring to remove all loose particles. If required, only use water based sweeping compounds. Do not use any wax or oil based compounds that leave behind a residue that may interfere with the adhesive bond.
- H. Perform moisture tests on concrete subfloors to determine if surfaces are sufficiently cured and dry as well as to ascertain presence of curing compound. Do not use curing compounds on concrete subfloors.
- I. Do not allow resilient flooring work to proceed until subfloor surfaces are satisfactory. Indicate adverse conditions of any type by letter.

### 3.02 PREPARATION

- A. Comply with ASTM F 710, Standard Practice for Preparing Concrete Floors to Receive Resilient Flooring, and manufacturer's recommendations for surface preparation. Remove substances incompatible with resilient flooring adhesive by method acceptable to manufacturer.
  - 1. Concrete floors with steel troweled (slick) finish shall be properly roughened (sanded) to ensure suitable adhesion.
  - 2. Concrete floors with curing, hardening and/or breaking compounds shall be abraded with mechanical methods only to remove compounds.
    - a. Do not use chemicals for removal.
    - b. Do not use wax or oil based sweeping compounds.
- B. Sand or grind subfloors to remove mortar, paint, other surface irregularities.
- C. Where filling, patching, leveling is required of thickness exceeding 1/8-inch apply latex type underlayment in two or more applications. Apply compound in accordance with manufacturer's printed instructions.
- D. Remove all debris, sand, and other materials which would result in lack of adhesion and/or star cracking.

### 3.03 INSTALLATION

- A. Comply with manufacturer's written instructions for installing resilient tile flooring.
- B. Resilient Rubber Floor Tile:
  - a. Install with Johnsonite adhesive specified for the site conditions and follow adhesive label for proper use.
  - b. Do not Quarter Turn tile.
  - c. Roll the flooring in both directions using a 100 pound three-section roller.
- C. Install resilient flooring, including but not limited to the following, in accordance with the manufacturer's installation instructions.
  - 1. Do not mix manufacturing batches of a color within the same area.
  - 2. Do not install resilient flooring over building expansion joints.
  - 3. Do not install defective or damaged resilient flooring.
  - 4. Layout resilient flooring to provide ~equal size at perimeter. Adjust layout as necessary to reduce the amount of resilient flooring which is cut to less than half full width.
  - 5. Lay resilient flooring with arrows in the same direction (excluding borders).
  - 6. Install resilient flooring without voids at seams. Lay seams together without stress.
  - 7. Cut/scribe resilient flooring neatly at perimeter and obstructions.
  - 8. Extend resilient flooring into reveals, closets, and similar openings.
  - 9. Remove excess adhesive immediately.
- D. Install reducer strips at exposed edges.

### 3.04 WALL BASE INSTALLATION

- A. Apply wall base to walls, columns, pilasters, casework and other permanent fixtures in rooms or areas where base is required.
- B. Install base in lengths as long as practicable, with preformed corner units, or fabricated from base materials with mitered or coped inside corners. Cut no shorter than full wall length.
- C. Tightly bond base to substrate throughout length of each piece, with continuous contact at horizontal and vertical surfaces.
  - 1. On masonry surfaces, or other similar irregular substrates, fill voids along top edge of resilient wall base with manufacturer's recommended adhesive filler material.
  - 2. Adhesive shall cover a minimum of 90 percent of ribbed back of base.
  - 3. Leave 1/4 inch uncovered space at top edge of base to prevent oozing.
  - 4. Roll base firmly, roll back toward starting point.

### 3.05 CLEANING

- A. Comply with manufacturer's written instructions for cleaning and protection of resilient products.
- B. Perform the following operations immediately after completing resilient product installation:
  - a. Remove adhesive and other blemishes from exposed surfaces.
  - b. Sweep and vacuum surfaces thoroughly.
  - c. Damp-mop surfaces to remove marks and soil.
- C. Protect resilient products from mars, marks, indentations, and other damage from construction operations and placement of equipment and fixtures during remainder of construction period.
- D. No traffic for 24 hours after installation.
- E. No heavy traffic, rolling loads, or furniture placement for 72 hours after installation.
- F. Wait 72 hours after installation before performing initial cleaning.

### 3.06 PROTECTION

- A. Protect flooring against damage during construction period to comply with resilient flooring manufacturer's directions.

END OF SECTION 09 65 00

SECTION 09 90 00

PAINTING

PART 1 - GENERAL

1.01 RELATED DOCUMENTS

- A. Conditions of the Contract and portions of Division One of this Project Manual apply to this Section as though repeated herein.

1.02 WORK INCLUDED

- A. Painting and finishing of interior exposed items and surfaces throughout Project.
- B. Refinishing as indicated on Drawings, including removal of paint and finishes, preparation, painting and finishing.
- C. Field painting of exposed bare and covered pipes and ducts and hangers, conduits, uni-strut, exposed steel and iron work, all metal fabricated Section 05 50 00 items, and primed metal surfaces including but not limited to, hollow metal work, equipment installed under mechanical and electrical work.
- D. "Paint" as used herein means all coating systems materials including primers, emulsions, enamels, stains, sealers and fillers, and other applied material whether used as prime, intermediate or finish coats.
- E. Except where natural finish of material is specifically noted as a surface not to be painted, paint exposed surfaces. Where items or surfaces are not specifically mentioned, paint the same as similar adjacent materials or areas.
- F. Following categories are not included as part of field-applied finish work.
  - 1. Pre-Finished Items: Unless otherwise indicated, do not include painting when factory-finishing or installer-finishing is specified.
  - 2. Concealed Surfaces: Unless otherwise indicated, painting is not required on surfaces in concealed areas and generally inaccessible areas.
  - 3. Finished Metal Surfaces.
  - 4. Operating Parts.

1.03 RELATED WORK

- A. Shop Priming: Unless otherwise specified, shop priming of ferrous metal items is included under various sections for structural steel, metal fabrications, hollow metal work and similar items.
- B. Examine the Contract Documents and be familiar with all their provisions regarding painting. All surfaces that are left unfinished by the requirements of other Sections shall be painted or finished as part of this Section.

1.04 SUBMITTALS

- A. Submit in accordance with the General Conditions of the Contract:
  - 1. Paint: Submit a list of specified products with corresponding name of manufacturer, identifying name and number of proposed products along with manufacturer's written instructions for use of each product.

- 1 2. If manufacturer to be used is different from that of color chips furnished, prepare and submit  
2 two approximately 6 inch square, properly labeled samples of each color and sheen required  
3 on properly prepared paint-out cards or hardboard.  
4
- 5 3. Prepare and repaint an area of each designated interior surface to requirements specified  
6 herein, with specified paint or coating showing selected color, gloss/sheen, texture and  
7 workmanship to MPI Repainting Manual standards for review and approval by Owner and  
8 A/E. When approved, interior surface shall become acceptable standard of finish quality and  
9 workmanship for similar on-site repainting work.

10  
11 1.05 QUALITY ASSURANCE

- 12  
13 A. Master Painters Institute (MPI) Standards:  
14 1. Products: Complying with MPI standards indicated and listed in "MPI Approved Products  
15 List."  
16  
17 2. Preparation and Workmanship: Comply with requirements in "MPI Architectural Painting  
18 Specification Manual" for products and paint systems indicated.  
19 a. For areas to be renovated, comply with requirements in "MPI Maintenance  
20 Repainting Manual".  
21

22 1.06 DELIVERY, STORAGE AND HANDLING

- 23  
24 A. Do not deliver materials to site until having received all written approvals of submitted information  
25 and samples.  
26  
27 B. Deliver materials to job site in original, new and unopened packages and containers bearing  
28 manufacturer's name and label.  
29  
30 C. Store materials not in actual use in tightly covered containers.  
31  
32 D. Take all precautions to ensure that workers and work areas are adequately protected from fire  
33 hazards and health hazards resulting from handling, mixing and application of paints.  
34  
35 E. Remove rags and waste from storage areas daily.  
36

37 1.07 PROJECT CONDITIONS

- 38  
39 A. Apply water-base paints only when temperatures of surfaces to be painted and surrounding air  
40 temperatures are between 50 and 95 degrees F.  
41  
42 B. Apply solvent-thinned paints only when temperature of surfaces to be painted and surrounding air  
43 temperatures are between 45 degrees F. and 95 degrees F.  
44  
45 C. Do not apply paint when relative humidity exceeds 85%; at temperatures less than 5 degrees F.  
46 above the dew point; or to damp or wet surfaces.  
47

48 1.08 SEQUENCING AND SCHEDULING

- 49  
50 A. Schedule cleaning and painting so that contaminants from cleaning process will not fall onto  
51 newly-painted surfaces.  
52

53 1.09 EXTRA MATERIALS



1 A. Furnish extra materials described below that are from same production run (batch mix) as materials  
2 applied and that are packaged for storage and identified with labels describing contents.

3  
4 1. Quantity: Furnish an additional 5 percent, but not less than 1 gal. of each material and color  
5 applied.

6  
7 1.010 ENVIRONMENTAL REQUIREMENTS

8  
9 A. Low-Emitting Materials, Field applied Paints and Coatings: Interior paints and coatings applied on-  
10 site must meet the limitations and restrictions concerning chemical components set by the following  
11 standards:

- 12 1. Topcoat Paints, Green Seal Standard GS-11, Paints: First Edition, May 20, 1993.  
13 2. Anti-Corrosive and Anti-Rust Paints: Green Seal Standard GS-03, Anti-Corrosive Paints",  
14 Second Edition, January 7, 1997. For applications on ferrous metal substrates.  
15 3. "All Other Architectural Coatings, Primers and Undercoats: South Coast Air Quality  
16 Management District (SCAQMD) Rule #1113, Architectural Coatings", rules in effect on  
17 January 1, 2004.

18  
19 PART 2 - PRODUCTS

20  
21 2.01 MANUFACTURERS

22  
23 A. AFM Safecoat.

24  
25 B. Benjamin Moore & Co.

26  
27 C. Cabot.

28  
29 D. ICI/Dulux.

30  
31 E. PPG Architectural Finishes, Inc.

32  
33 F. Sherwin Williams Company.

34  
35 G. U-C Coatings Corp.

36  
37 H. Target Coatings

38  
39 I. Diamond Vogel Paint

40  
41 J. Or approved equal.

42  
43 2.02 MATERIALS

44  
45 A. Use the materials of the same manufacturer for each system.

46  
47 B. Sherwin Williams systems are called out in the system schedules to establish quality and dry mil  
48 thickness of finished installation for all systems. A different manufacturer may be used for color  
49 selection. Any manufacturer noted above may be used as long as quality and color requirements are  
50 met.

51  
52 1. Proprietary names used to designate colors or materials are not intended to imply that  
53 products of named manufacturers are required to exclusion of equivalent products of other  
54 manufacturers.

55

1 C. Provide best quality grade of various types of coatings as regularly manufactured by acceptable paint  
2 materials manufacturers.

3  
4 D. Material Compatibility:

- 5  
6 1. Provide materials for use within each paint system that are compatible with one another and  
7 substrates indicated, under conditions of service and application as demonstrated by  
8 manufacturer, based on testing and field experience.  
9  
10 2. For each coat in a paint system, provide products recommended in writing by manufacturers  
11 of topcoat for use in paint system and on substrate indicated.  
12

13 E. Chemical Components of Field-Applied Interior Paints and Coatings: Provide products that comply  
14 with the following limits for VOC content, exclusive of colorants added to a tint base, when  
15 calculated according to 40 CFR 59, Subpart D (EPA Method 24) and the following chemical  
16 restrictions; these requirements do not apply to primers or finishes that are applied in a fabrication or  
17 finishing shop:  
18

- 19 1. Flat Paints and Coatings: VOC content of not more than 50 g/L.  
20 2. Non-flat Paints and Coatings: VOC content of not more than 150 g/L.  
21 3. Aromatic Compounds: Paints and coatings shall not contain more than 1.0 percent by weight  
22 of total aromatic compounds (hydrocarbon compounds containing one or more benzene  
23 rings).  
24 4. Restricted Components: Paints and coatings shall not contain any of the following:  
25  
26 a. Acrolein.  
27 b. Acrylonitrile.  
28 c. Antimony.  
29 d. Benzene.  
30 e. Butyl benzyl phthalate.  
31 f. Cadmium.  
32 g. Di (2-ethylhexyl) phthalate.  
33 h. Di-n-butyl phthalate.  
34 i. Di-n-octyl phthalate.  
35 j. 1,2-dichlorobenzene.  
36 k. Diethyl phthalate.  
37 l. Dimethyl phthalate.  
38 m. Ethylbenzene.  
39 n. Formaldehyde.  
40 o. Hexavalent chromium.  
41 p. Isophorone.  
42 q. Lead.  
43 r. Mercury.  
44 s. Methyl ethyl ketone.  
45 t. Methyl isobutyl ketone.  
46 u. Methylene chloride.  
47 v. Naphthalene.  
48 w. Toluene (methylbenzene).  
49 x. 1,1,1-trichloroethane.  
50 y. Vinyl chloride.  
51

52 F. Color Pigments: Pure, non-fading, applicable types to suit substrates and service indicated.  
53

54 2.03 PRIMERS/SEALERS  
55

- 1       A.     Interior Latex Primer/Sealer: MPI #50.  
2  
3     2.04    METAL PRIMERS  
4  
5       A.     Rust-Inhibitive Primer (Water Based): MPI #107.  
6  
7     2.05    LATEX PAINTS  
8  
9       A.     Institutional Low-Odor/VOC Latex (Flat): MPI #143 (Gloss Level 1).  
10  
11       B.     Institutional Low-Odor/VOC Latex (Low Sheen): MPI #144 (Gloss Level 2).  
12  
13       C.     Institutional Low-Odor/VOC Latex (Eggshell): MPI #145 (Gloss Level 3).  
14  
15       D.     Institutional Low-Odor/VOC Latex (Semigloss): MPI #147 (Gloss Level 5).  
16  
17    2.06    EQUIPMENT  
18  
19       A.     Provide all brushes, rollers, ladders, scaffolding, and other equipment of any kind to properly  
20             execute each type of work.  
21  
22    PART 3 - EXECUTION  
23  
24    3.01    EXAMINATION  
25  
26       A.     Examine substrates and conditions, with Applicator present, for compliance with requirements for  
27             maximum moisture content and other conditions affecting performance of work.  
28  
29       B.     Maximum Moisture Content of Substrates:  
30             1.     Gypsum Board: 12 percent.  
31             2.     Concrete: Must be cured a minimum of 45 days.  
32  
33       C.     Verify suitability of substrates, including surface conditions and compatibility with existing finishes  
34             and primers.  
35  
36       D.     Begin coating application only after unsatisfactory conditions have been corrected and surfaces are  
37             dry.  
38             1.     Beginning coating application constitutes Contractor's acceptance of substrates and  
39             conditions.  
40  
41    3.02    PREPARATION  
42  
43       A.     Perform preparation and cleaning procedures in accord with paint manufacturer's instructions and as  
44             specified for each particular substrate condition.  
45             1.     Remove hardware, hardware accessories, machined surfaces, plates, lighting fixtures, and  
46             similar items in place and not to be finish-painted, or provide surface-applied protection prior  
47             to surface preparation and painting operations.  
48                 a.     After completing painting operations, use workers skilled in the trades involved to  
49                 reinstall items that were removed. Remove surface-applied protection if any.  
50                 b.     Do not paint over labels of independent testing agencies or equipment name,  
51                 identification, performance rating, or nomenclature plates.  
52  
53             2.     Clean surfaces to be painted before applying paint or surface treatments. Remove oil and  
54             grease prior to mechanical cleaning.

1 3. Remove dirt, rust, scale, moisture, scuffed surfaces, or conditions otherwise detrimental to  
2 formation of a durable paint film.  
3

4 B. Gypsum Board: Fill minor irregularities with patching material and sand to smooth level surfaces  
5 taking care not to raise nap of paper.  
6

7 C. Existing Ferrous Metal  
8

9 1. Spot remove failed, damaged or rough existing paint to bare metal by means of stripping as  
10 indicated above. If existing metal surface is not smooth, sand or wire brush.

11 a. Sand edges of existing paint to a feather edge.

12 2. Remove dirt and grease with mineral spirits or solvent recommended by paint manufacturer  
13 and clean cloths.  
14

15 D. Ferrous Metal  
16

17 1. Remove dirt and grease with mineral spirits or solvent recommended by paint manufacturer  
18 and clean cloths.

19 2. Where not galvanized, shop coat of primer will exist on surface. If prime coat is not smooth,  
20 sand to bare metal and re-prime.  
21

### 22 3.03 APPLICATION 23

24 A. Provide adequate forced ventilation of enclosed areas for curing of installed materials, to disperse  
25 humidity, and to prevent hazardous accumulations of dust, fumes, vapors or gases.  
26

27 B. Do work under adequate illumination and dust-free conditions.  
28

29 C. Apply paints according to manufacturer's written instructions.

30 1. Use applicators and techniques suited for paint and substrate indicated.

31 2. Paint surfaces behind movable equipment and furniture same as similar exposed surfaces.  
32 Before final installation, paint surfaces behind permanently fixed equipment or furniture with  
33 prime coat only.

34 3. Paint front and backsides of access panels, removable or hinged covers, and similar hinged  
35 items to match exposed surfaces.  
36

37 D. Tint each undercoat a lighter shade to facilitate identification of each coat if multiple coats of same  
38 material are to be applied. Tint undercoats to match color of topcoat, but provide sufficient  
39 difference in shade of undercoats to distinguish each separate coat.  
40

41 E. Materials

42 1. Do not open containers until required for use.

43 2. Stir materials thoroughly and keep at uniform consistency during application.  
44

45 F. Coats

46 1. Number specified is minimum.

47 2. Touch up suction spots between coats.

48 3. If undercoats or other conditions show through topcoat, apply additional coats until cured  
49 film has a uniform paint finish, color, and appearance.

50 4. Apply paints to produce surface films without cloudiness, spotting, holidays, laps, brush  
51 marks, roller tracking, runs, sags, ropiness, or other surface imperfections. Cut in sharp lines  
52 and color breaks.

53 5. Refinish surfaces affected by refitting work.  
54

### 55 3.04 COLOR SEPARATION

1  
2  
3  
4  
5  
6  
7  
8  
9  
10  
11  
12  
13  
14  
15  
16  
17  
18  
19  
20  
21  
22  
23  
24  
25  
26  
27  
28  
29  
30  
31  
32  
33  
34  
35  
36  
37  
38  
39  
40  
41  
42  
43  
44  
45  
46  
47  
48  
49  
50  
51  
52  
53  
54  
55

- A. An average of one or two wall colors will be used per room. Ceilings generally will be a different color than walls. Finished closets will usually be same as adjoining rooms.
- B. Job painted metal items such as diffusers, grilles and registers will generally be same color as adjacent surface.
- C. Hardwood generally will be the same color stain throughout.

3.05 CLEANING

- A. During the progress of this work, remove from the site all discarded paint materials, rubbish, cans and rags at the end of each work day.
- B. Upon completion of painting work, clean window glass and other paint-spattered surfaces. Remove spattered paint by proper methods of washing and scraping, using care not to scratch or otherwise damage finished surfaces.

3.06 PROTECTION

- A. Protect work of other trades, whether to be painted or not, against damage by painting and finishing work. Correct damage by cleaning, repairing or replacing.
- B. Provide "wet paint" signs to protect newly-painted finishes. Remove temporary protective wrappings, after completion of painting operations.
- C. At the completion of work of other trades, touch-up and restore all damaged or defaced painted surfaces.

3.07 SCHEDULE OF INTERIOR WORK

- A. In addition to obvious surfaces, the following do not require painting or finishing.
  - 1. Do not include painting when factory-finishing or installer-finishing is specified for such items as (but not limited to) acoustic materials, finished mechanical and electrical equipment including light fixtures and distribution cabinets.
  - 2. Painting is not required on surfaces such as walls or ceilings in concealed areas and generally inaccessible areas, furred areas, utility tunnels, pipe spaces, duct shafts and elevator shafts.
  - 3. Metal surfaces of anodized aluminum, stainless steel, chromium plate, copper, bronze and similar finished materials will not require finish painting, unless otherwise indicated.
  - 4. Moving parts of operating units, mechanical and electrical parts, such as valve and damper operators, linkages, sinkages, sensing devices, motor and fan shafts will not require finish painting, unless otherwise indicated.
  - 5. Do not paint over any code-required labels, such as Underwriter's Laboratories and Factory Mutual, or any equipment identification, performance rating, name or nomenclature plate.
  - 6. N/A indicates system not applicable to this Project.
- B. Walls and Ceilings
  - 1. Paint all rooms. Paint patched walls from 90 degree corner and patched ceilings complete.
  - 2. Do not apply next coat until previous is thoroughly dry.
  - 3. Provide final coat which is solid and even in color, free from runs, laps, sags, brush marks, air bubbles and excessive roller stipple and worked into crevices, joints and similar areas.
- C. Electrical Panel Box Covers and Doors
  - 1. Remove, paint and reinstall after paint is dry.

1 D. Other Unfinished and Primed Surfaces

- 2  
3 1. Provide specified finish on exposed surfaces. This includes prime coated mechanical units,  
4 piping, pipe covering, conduit, and interior duct surfaces visible behind grilles.  
5

6 E. Material Type Number and Type of Coating  
7

System	Material	Type/Sheen	Number and Type of Coating
IPS-4	Wood	Water-based Stain, Transparent/Satin	One coat "Wood Classics 250"; Two coats "Target Coatings 9000 Series 'Clear Coat' Polyurethane Ultra-Low VOC"; Custom colors to match A/E's finish control sample
IPS-6	Gypsum Board	Epoxy-Gloss	One coat "ProMar Primer" Two coats "Water based Catalyzed Epoxy"
IPS-7	Gypsum Board	Latex-Eggshell Zero VOC	One coat "Harmony Interior Latex Primer", Two coats "Harmony Interior Latex Eggshell".
IPS-13	Ferrous Metal (Unprimed)	Latex/Semi-gloss	One coat "Pro-Cryl Universal Primer"; Two coats "ProClassic Waterborne"
IPS-14	Ferrous Metal (Primed)	Latex/Semi-gloss	One coat "Pro-Cryl Universal Primer"; Two coats "ProClassic Waterborne"
IPS-15	Copper/Aluminum (finished rooms only)	Latex/Flat	One coat "DTM Acrylic Primer; Finish"; Two coats "ProMar 200 Interior Latex Flat"
IPS-16	Galvanized Metal (finished rooms only)	Latex/Flat	One coat "DTM Acrylic Primer Finish"; Two coats "ProMar 200 Interior Latex Flat"

8

System	Material	Type/Sheen	Number and Type of Coating
EPS-1	Ferrous Metal (hollow metal, exposed plates, angles, bolts, etc.)	Latex /Semi-Gloss	One coat "Kem-Kromik Universal" primer; Two coats "DTM Acrylic"
EPS-2	Galvanized Metal (hollow metal, equipment housings, steel, etc.)	Latex /Semi-Gloss	One coat "Pro-Cryl Univeral" primer; Two coats "DTM Acrylic"

9  
10 F. Color Schedule

- 11 PT-1: GWB Ceiling  
12 PT-2: Exposed Ceiling  
13 PT-3: Field  
14 PT-4: Field - Restrooms  
15 PT-5: Field – Open Office  
16 PT-6: Accent - Wrap  
17 PT-7: Accent  
18  
19  
20  
21

END OF SECTION 09 90 00

SECTION 10 14 00

INFORMATION SPECIALTIES

PART 1:GENERAL

1.01 RELATED DOCUMENTS

- A. Conditions of the Contract and portions of Division One of this Project Manual apply to this Section as though repeated herein.

1.02 WORK INCLUDED

- A. Accessibility Signage.
- B. Pressure Sensitive Graphic Window Films.

1.03 REFERENCES

- A. All signage shall be in strict accord with Wisconsin Enrolled Commercial Building Code.

1.04 SUBMITTALS

- A. Submit in accordance with the General Conditions of the Contract.
  - 1. Manufacturer's Literature: Graphics with text, materials description, colors, and application instructions.

1.05 DELIVERY, STORAGE AND HANDLING

- A. Provide protective coverings for identifying devices prior to shipping.
- B. Handle and store to prevent damage and soiling.

PART 2:PRODUCTS

2.01 ADA REQUIRED ACCESSIBILITY SIGNAGE

- A. All interior signage must have tactile/Braille lettering and raised pictograms. Braille must be integral to the sign. Taped on Braille is not acceptable.
  - 1. All Braille to be located at the bottom of the sign.
  - 2. When the word "accessible" is used on a sign or when the symbol for accessibility is used, the word accessible must be included in the Braille text.
- B. Exterior Signs
  - 1. All Braille to be located at the bottom of the sign.
  - 2. When the word "accessible" is used on a sign or when the symbol for accessibility is used, the word accessible must be included in the Braille text.
  - 3. Size: Approximately 6" x 10".
  - 4. Material: Plastic for exterior use.
  - 5. Color: As selected by Architect from manufacturer's full range.
- C. Manufacturers
  - 1. ASI Sign Systems.
  - 2. Poblocki Sign Company

3. Best Sign Systems Inc.
4. 2/90 Sign Systems
5. Or approved equal.

- D. Provide proper gender symbol at each door leading to a room designed for handicap use (i.e., toilet rooms with grab bars, etc.).

#### 2.02 Pressure sensitive Graphic Window Films

- A. Vinyl glass film, 50 micron
  1. Basis of Design: 3M 7725-314 Dusted Crystal
  2. Color and pattern to be selected by A/E
  3. Clear release liner.
  4. Pressure sensitive adhesive.
  5. To give appearance of etched glass as chosen by A/E.  
Application location as indicated on A7.1.
- B. Manufacturers.
  1. Metamark Signviny
  2. 3M
  3. Or approved equal.

### PART 3:EXECUTION

#### 3.01 INSTALLATION

- A. Comply with manufacturer's specifications and recommendations for the installation of identification devices.
- C. Install devices plumb, level and true to line.
- D. Install room and door identification signs at 5 feet from centerline of signs to finished floor.
  1. When used in conjunction with accessibility symbol, mount below symbol.

#### 3.02CLEANING

- A. Clean surfaces of identifying devices, dedication plaque and surrounding surfaces.
- B. Remove protective coatings, if any.

#### 3.03SIGNAGE SCHEDULE

- A. ADA Signage to be provided at Womens 082, Mens 080.

END OF SECTION 10 14 00



SECTION 10 21 13

TOILET COMPARTMENTS

PART 1 - GENERAL

1.01 RELATED WORK

- A. Conditions of the Contract and portions of Division One of this Project Manual apply to this Section as though repeated herein.

1.02 WORK INCLUDED

- A. Baked enamel steel toilet compartments, Doors and Urinal Screens – all components are ceiling or wall mounted.
- B. Attachment hardware.

1.03 RELATED WORK

- A. Metal Fabrications: Section 05 50 00.
- B. Cold-Formed Metal Framing: 05 40 00.
- C. Rough Carpentry: Section 06 10 00.
- D. Gypsum Board: Section 09 29 00.
- E. Toilet, Bath and Laundry Accessories: Section 10 28 00.

1.04 REFERENCES

- A. All work shall be in strict accord with Wisconsin Enrolled Commercial Building Code.
- B. ANSI A117.1 – Accessible and Usable Buildings and Facilities.
- C. ADAAG – Americans with Disabilities Act for Accessibility Guidelines.
- D. ASTM A167 – Stainless and Heat-Resisting Chromium-Nickel Steel Plate, Sheet, and Strip.

1.05 SUBMITTALS

- A. Submit in accordance with the General Conditions of the Contract.
  - 1. Shop drawings showing scale, drawings of plan, all elevations of all compartments, indicate clearly the hardware, and accessories to be furnished.
  - 2. Fully coordinate with structural framing submittal.
  - 3. Verify field dimensions.
  - 4. Part of the submittal may consist of standard brochures.
  - 5. Shop drawings that clearly show attachment locations for all blocking and anchorages.
  - 6. Shop drawings that show locations and drilling dimensions.
  - 7. Two sets of color samples.

1.06 DELIVERY, STORAGE AND HANDLING

- A. Deliver compartments in suitable crating or packaging to prevent damage in transit and storage.

- 1  
2 B. Coordinate delivery with progress schedule to reduce period of on-site storage. Store under cover in  
3 a dry area.  
4

5 1.07 FIELD MEASUREMENTS  
6

- 7 A. Verify field measurements are as shown on Drawings, shop drawings and as instructed by the  
8 manufacturer.  
9

10 PART 2 - PRODUCTS  
11

12 2.01 TOILET PARTITIONS  
13

- 14 A. Ceiling Mounted.  
15 1. Basis for Design: Ampco Products.  
16  
17 B. Comparable models by:  
18 1. American Building Specialties Corp.  
19 2. Or approved equal.  
20

21 2.02 FEATURES  
22

- 23 A. Material:  
24 1. Baked enamel steel sheets, complying with ASTM A 879 Class C and ASTM A-653;  
25 galvanized, bonderized, and electrostatically applied powder coat paint finish; bonded to  
26 kraft honeycomb core, impregnated with sound-deadening resin; edges with continuous  
27 rolled-formed interlocking strip; corners welded and ground smooth, mechanical corner  
28 fastenings not acceptable.  
29 2. Color as selected by A/E from manufacturer's full line.  
30  
31 B. Fasteners, Anchorages: Manufacturer's standard stainless steel to accommodate solid surface.  
32 1. Through bolts and nuts, stainless steel with tamperproof heads.  
33 2. Anchorage devices with threaded rod, lock washers, and leveling adjustment nuts at pilaster  
34 connection for structural support above finished ceiling; devices designed to support pilasters  
35 from structure without transmitting load to finished ceiling; pilaster shoe to conceal  
36 anchorages.  
37  
38 C. Hardware: Material: Stainless steel, complying with ADA standards.  
39 1. Hinges: Bathroom Stall Full Length Stainless Steel Continuous self closing hinges that can  
40 be adjusted to hold door open in any position. 54 1/2" 1/4" Pin. 14 Gauge.  
41 2. Coat Hook: Combination hook and rubber tipped bumper, sized to prevent door from hitting  
42 accessories or wall.  
43 3. Latch and keeper: Surface mount designed for emergency access.  
44 4. Stainless steel pulls where required for operation.  
45 5. Door bumper: Rubber tipped as needed at out swinging doors.  
46 6. Door pull.  
47

48 2.03 FABRICATION  
49

- 50 A. Furnish standard doors, panels, screens and stiles fabricated for compartment system. Furnish units  
51 with cutouts and drilled holes to receive compartment hardware as indicated.  
52 B. Metal, Powder Coated Baked Enamel: One-piece face sheets shall be bonded to core material. Edges  
53 shall have a continuous rolled- formed interlocking strip. Corners shall be welded and ground  
54 smooth. Mechanical corner fastenings will not be acceptable.  
55 C. Doors and urinal screens: 1". Provide wall mounting details for blocking installation and brackets.

- 1 D. Pilasters: 1 1/4" thick pilasters shall be the same construction as panels.  
2 1. The mounting system at the top of the pilaster shall be concealed by trim.  
3

4 2.04 FINISHES

- 5  
6 A. Finish color and pattern selected by A/E from manufacturer's full range.  
7  
8 B. Stainless Steel: No. 4 polished finish on all exposed hardware.  
9

10 PART 3 - EXECUTION

11  
12 3.01 INSTALLATION

- 13  
14 A. Installation of all doors and screens shall be done in compliance with manufacturer's instructions and  
15 approved shop drawings.  
16  
17 B. Evidence of drilling in walls shall be concealed in the finished work.  
18  
19 C. Install partition components secure, plumb and level.  
20  
21 D. Attach panels and pilasters to brackets with through bolts and nuts.  
22  
23 E. Anchor urinal screens to walls with continuous brackets.  
24  
25 F. Provide 1/2 inch space between wall surface and panels.  
26  
27 G. Anchor pilasters to ceiling with adjustable leveling anchors.  
28  
29 H. Hang doors and adjust so door bottoms are 12 inches (305 mm) off floor when doors are in closed  
30 position.  
31

32 3.02 CLEANING

- 33  
34 A. Remove all protective maskings and clean surfaces. Leave them free of soil and imperfections.  
35  
36 B. Provide owner with hinge lubricant and maintenance instructions.  
37

38 3.03 PROTECTION

- 39  
40 A. Field touch-up of finished surfaces will not be permitted. Replace damaged components.  
41  
42

43 END OF SECTION 10 21 13  
44

SECTION 10 28 00

TOILET, BATH AND LAUNDRY ACCESSORIES

PART 1 - GENERAL

1.01 RELATED DOCUMENTS

- A. Applicable provisions of Division 1 shall govern the work under this section.

1.02 WORK INCLUDED

- A. Commercial Toilet and Bath Accessories

1.03 REFERENCES

- A. All work of this section shall be in strict accord with Wisconsin Enrolled Commercial Building Code.

1.04 SUBMITTALS

- A. Submit in accordance with the General Conditions of the Contract.
  - 1. Manufacturer's product data.

1.05 DELIVERY, STORAGE, AND HANDLING

- A. Deliver materials in original packaging with seals unbroken and bearing manufacturer's name and product.
- B. Store all materials in secure place to prevent damage.
- C. Remove all damaged materials from project immediately.

1.06 SUSTAINABLE DESIGN REQUIREMENTS

- A. Low-Emitting Materials, Adhesives, and Sealants: Materials used on the interior of the building (defined as inside the weatherproofing system and applied on site) must not exceed the following requirements.
  - 1. Adhesives, Sealants and Sealant Primers: South Coast Air Quality Management (SCAQMD) Rule # 1168, requirements in effect on July 1, 2005, and rule amendment date January 7, 2005.
  - 2. Aerosol Adhesives: Green Seal Standard for Commercial Adhesives GS-36, requirements in effect on October 19, 2000.

PART 2 - PRODUCTS

2.01 MANUFACTURED COMMERCIAL UNITS

- A. Grab Bars:
  - 1. Bradley Model 812
    - 1. Or approved equal
  - 2. 1-1/2" diameter, 18 gauge, type 304 stainless steel
  - 3. Concealed-mounting
  - 4. Lengths as indicated on drawings

- 1 B. Toilet Tissue (Roll) Dispenser:
- 2 1. O.F.C.I at each water closet.
- 3
- 4 C. Soap Dispenser:
- 5 1. O.F.C.I. wall mounted adjacent to each lav faucet.
- 6 2. County to provide prior to lav rough in.
- 7
- 8 D. Warm-Air Dryers (DRYER):
- 9 1. Xlerator Hand Dryer
- 10 1. Or approved equal
- 11 2. Noise Reduction Nozzle
- 12 3. ADA Compliant Projection
- 13 4. Surface recessed
- 14 5. Operation: Electronic-sensor activated with timed power cut-off switch
- 15 1. Operation Time: 10 to 15 seconds
- 16 6. Cover Material and Finish: Steel, with black graphite epoxy finish
- 17 7. Electrical Requirements
- 18 1. 120 V, 13 A, 1500 W
- 19 2. Each hand dryer shall have a dedicated 20amp circuit
- 20
- 21 E. Sharps disposal – O.F.O.I.
- 22
- 23 F. Sanitary Napkin Dispenser – O.F.O.I.
- 24
- 25 G. Sanitary Napkin Disposal
- 26 1. Install in each womens stall.
- 27 2. Stainless steel
- 28 3. Bradley 4722-15
- 29 4. Or approved equal.
- 30
- 31 H. Waste Receptacle with Paper Towel Dispenser:
- 32 1. County to confirm towel type prior to submittal.
- 33 2. Bobrick B-43644 with liner
- 34 3. Contura Series Recessed Waste Receptacle with liner, 15 gallon capacity
- 35
- 36 I. Diaper Changing Station (DCS)/ Baby Changing Station (BCS)
- 37 1. Koala Kare HDPE
- 38 1. Or approved equal
- 39 2. Horizontal unit that opens by folding down from stored position and with child-protection
- 40 strap.
- 41 1. Engineered to support a minimum of 250-lb static load when opened
- 42 3. Operation: By pneumatic shock-absorbing mechanism
- 43 4. Stainless steel finish with HDPE interior in manufacturer's standard color
- 44 5. Liner Dispenser: Built in
- 45
- 46 J. Clothes Hook
- 47 1. B-6727 SS Bobrick
- 48 2. Or approved equal
- 49 3. See drawings for locations.
- 50 4. Install (4) in Room Women 082: (1) at 4'-0" AFF, remainder at 5'-6" AFF, 12" on center.
- 51
- 52 K. Stainless steel shelf, see drawings for locations
- 53 1. American Specialties 0692-548 5"x48"
- 54 2. Or approved equal.
- 55 3. 18 gauge stainless steel, stain finish.
- 56 4. Match mirror glass width, see drawings and section 08 80 00.
- 57

58 2.02 SEALANT

59

1 A. "G-E silicone sealant", General Electric Company.

2  
3 B. "Dow Corning 780", Dow Corning Corporation.

4  
5 C. "Pecora 826", Pecora Chemical Corporation.

6  
7 2.03 FASTENERS

8  
9 A. Provide all fastening devices including screws, bolts, anchors, and backplates.

10  
11 B. Exposed fasteners shall match finish of accessories.

12  
13 2.04 FABRICATION

14  
15 A. Fabricate all toilet and bath accessories of type 302 or 304 stainless steel with satin finish, unless  
16 otherwise specified or approved.

17  
18 B. All accessories shall be by one manufacturer unless otherwise specified or approved.

19  
20 C. Manufacturer's labels or imprinted name shall not be visible.

21  
22 PART 3 - EXECUTION

23  
24 3.01 EXAMINATION

25  
26 A. Examine surfaces and recesses to receive toilet and bath accessories for dimensions, plumbness,  
27 blocking, and other conditions that affect installation.

28  
29 B. Do not proceed until conditions are acceptable.

30  
31 3.02 INSTALLATION

32  
33 A. Install toilet and bath accessories according to manufacturer's direction.

34  
35 B. All accessories in any one space shall be of matching design and finish. If discrepancies are found,  
36 secure Architect's approval before proceeding.

37  
38 C. Set all recessed and semi-recessed accessories with continuous seal of sealant, around entire  
39 perimeter of all accessories to prevent moisture from reaching substrate.

40  
41 3.03 ADJUSTING AND CLEANING

42  
43 A. Adjust accessories for proper operation.

44  
45 B. Replace damaged or defective items.

46  
47 C. Clean and polish accessories after removing labels and protective wrapping.

48  
49 D. Delivery accessory keys, service, and parts manual in accordance with the General Conditions of the  
50 Contract Closeout.

51  
52 3.04 SCHEDULE

53  
54 A. Provide accessories as indicated on the drawings or specification.

55  
56 END OF SECTION

SECTION 10 51 13

LOCKERS

PART 1 - GENERAL

1.01 RELATED DOCUMENTS

- A. Conditions of the Contract and portions of Division One of this Project Manual apply to this Section as though repeated herein.

1.02 WORK INCLUDED

- A. Lockers

1.03 RELATED WORK

- A. Section 06 10 00, Rough Carpentry.

1.04 SUBMITTALS

- A. Submit in accordance with the General Conditions of the Contract.
  - 1. Shop drawings: Indicate installation details relating to anchoring, trim installation and relationship to adjacent surfaces, materials used, quantity and size required
  - 2. Samples: Indicate locker body, door colors.
    - a. Provide 12" x 12" samples of colors and finishes on actual material being used.
- B. Provide manufacturer's written warranty.

1.05 DELIVERY, STORAGE AND HANDLING

- A. Deliver, store and handle units to prevent damage.
- B. Damaged units will be rejected and replaced at no cost to Owner.

PART 2 - PRODUCTS

2.01 MANUFACTURERS

- A. Lyon Lockers:
  - 1. Standard Quiet Lockers
  - 2. Contact: John Cinto 608.239.8902

- B. Or approved equal.

2.02 MATERIALS

- A. Locker Box
  - 1. Triple Tier 18"x18"x24" lockers.
  - 2. Hinges: full loop design hinges, high security single point latches
    - a. Hardware: chrome finish.
  - 3. Vented doors.
  - 4. One piece doors formed from 16-gauge prime, high grade class 1 steel. Integral full height 16-gauge door strikes. 12-gauge door jambs.
  - 5. Number Plates: 1-1/2" disc with black engraved number routed flush with locker door.





SECTION 12 24 13

ROLLER WINDOW SHADES

PART 1 - GENERAL

1.01 RELATED DOCUMENTS

- A. Conditions of the Contract and portions of Division One of this Project Manual apply to this Section as though repeated herein.

1.02 WORK INCLUDED

- A. Manually operated sunscreen roller shades on all exterior windows within the project scope.

1.03 RELATED WORK

- A. Rough Carpentry, Section 06 10 00: blocking for support of window shade brackets.
- B. Substrate for window shade systems and installation of accessories supplied only under this section.

1.04 QUALITY ASSURANCE

- A. Manufacturer shall have 15 years experience in the manufacture of products comparable with those specified in this section.
- B. Manufacturer shall provide all shading components and electrical components for a complete installation and a single source of shading and lighting control where applicable.
- C. The manufacturer or licensed agent shall be approved to provide the products specified, honor all claims against the product in accordance with the warranty.
- D. Manufacturer shall provide 24/7 technical support to aid in troubleshooting system wiring and assist in system programming.
- E. Installer shall be qualified for installation by experience and be approved by the manufacturer.

1.05 SUBMITTALS

- A. Submit manufacturer's descriptive literature for each product type specified. Details shall indicate materials, finishes, construction, and mounting requirements. Also include installation and operating instructions.

1.06 SHOP DRAWINGS

- A. Indicate Head, jamb, and sill details to aid General Contractor to coordinate work as well as relevant dimensions and mounting requirements for each product type and mounting condition.
- B. Provide shade schedule coordinating room number, opening size(s), quantities and key to details.
- C. Submit a proposed seaming diagram for Architect approval at any openings where seams are required. Utilize manufacturer's maximum fabric dimension to minimize seams.

1.07 SAMPLES

- 1 A. Portfolio of shade fabric swatches for initial fabric color selection from manufacturer's full range of  
2 available fabrics. Provide sample and profiles of all aluminum fascias for selection from  
3 manufacturer's full range of available fascias.  
4
- 5 B. Material samples for color and finish selection of controls.  
6
- 7 C. One fully operational window shade sample of each type required complete with selected shade fabric  
8 including sample of seam/batten when applicable. Location of sample to be determined by Architect.  
9
- 10 D. One complete set of all shade components demonstrating compliance.  
11

12 1.08 CERTIFICATION

- 13
- 14 A. Test Reports indicating compliance with Fabric test properties listed in Section 2.  
15

16 1.09 MANUFACTURER'S INSTRUCTION

- 17
- 18 A. Installation, Programming, and Maintenance instructions to be included in product packaging.  
19
- 20 B. 24-Hour / 7-Day Technical support shall be available to aid with unforeseen installation difficulties.

21 1.10 DELIVERY, STORAGE, AND HANDLING

22 A. Storage and Protection

- 23 1. Do not deliver items to the project until all concrete, masonry, plaster, painting and other wet  
24 work has been completed and is dry.
- 25 2. Deliver shades to project in protective packaging, uniquely labeled to identify each shade for each  
26 opening. Schedule delivery to prevent delays to completion of work, but to minimize on-site  
27 storage time.
- 28 3. Store materials in a dry, secure place. Protect from weather, surface contaminants, corrosion,  
29 construction traffic, and all other potential damage.

30 B. PROJECT / SITE CONDITIONS

- 31 1. Shade system shall not be installed until the building is operating in ambient temperature and  
32 humidity ranges consistent with that intended for buildings ultimate use.

33 C. SCHEDULING

- 34 1. Do not fabricate shades without obtaining field dimensions for each opening.
- 35 2. Coordinate construction of surrounding conditions to allow for timely field dimension verification.
- 36 3. Manufacturer's standard lead times apply. Reference submittal and schedule accordingly for  
37 project timeline.

38 D. EXTRA MATERIALS

- 39 1. The manufacturer shall make available to the end user a method of ordering new equipment for  
40 expansions, replacement, or parts to be used as spares twenty-four hours a day, seven days a week.
- 41 2. The manufacturer must make available new or remanufactured parts for a minimum period of ten  
42 years from the final date of commissioning.

43 PART 2 - PRODUCTS

44 1.01 MANUFACTURERS

- 45 A. To establish the standard of quality, design, and function desired, drawings and specifications are

- 1 based on the Manual Solar Shades by:  
2 1. Springs Window Fashions, SWFcontract.  
3 2. Or approved equal by MechoShade Systems, Inc., Hunter Douglas, or approved equal.  
4 3. Dealer contact information: Interiors by J&L, Janice Quinton, 608.592.4221 or other approved  
5 dealer.

6 1.02 GENERAL SYSTEM SPECIFICATIONS

7 A. OPERATION

- 8 1. Manual.

9 1.03 ROLLER SHADES

10 A. MOUNTING

- 11 1. Roller shade brackets shall allow for symmetrical light gaps as small as  $\frac{3}{4}$ " on each side of  
12 shade.  
13 2. System shall have a roller shade leveling adjustment that allows level adjustment while the  
14 roller shades are mounted to the brackets.  
15 3. System shall allow a side-to-side adjustment of up to  $\pm 3/8$ " on each side while the shade is  
16 mounted to the bracket to properly center shade over the window.  
17 4. System shall have a projection adjustment of up to  $1/2$ " allowing the shade to clear the trim or  
18 move the shade closer to the window in order to have a tighter seal between the fabric and the  
19 window.  
20 5. System dual brackets shall be provided to permit two shades rollers to be mounted in the same  
21 opening .

22 B. SHADE TUBE

- 23 1. 2.5" aluminium extrusion  
24 2. Fabric shall be connected to the tube with double-sided adhesive strip applied for exact and firm  
25 mounting of the fabric and for easy adjustment of fabric to prevent telescoping.  
26 3. A minimum of one turn of fabric will be placed on the roller before the working section of  
27 fabric starts, to protect the fabric and smooth out the starting seam.

28 C. FABRICS

- 29 1. Qualifications  
30 a. Fire – Provide shade fabrics tested in accordance with:  
31 i. 1989 NFPA 701 small scale Vertical Burn Test and rated "PASS."  
32 ii. 1996 NFPA 701 small scale Vertical Burn (telephone booth test) and rated "PASS."

33 E. MANUFACTURING

- 34 1. Where applicable, shade fabric will be ultrasonically cut and friction sealed to minimize fraying.  
35 2. Woven yarn fabrics will be interlocking and heat-treated so that all material is securely bonded.  
36 3. Shade Fabric panels shall be 100% visually inspected for defects using a light box integrated  
37 into the manufacturing line.  
38 4. 100% visual inspections shall be performed on each shade seam and hem bar welds and  
39 compared to strict aesthetic standards.

- 1 5. Shade seam weld strength process shall be tested on a daily basis to ensure controlled  
2 consistency of weld quality.
- 3 6. Shade panels shall be 100% checked for squareness ( $\pm 1/16''$ )
- 4 7. Shade panels shall be 100% visually inspected to ensure there are no frayed edges or defects in  
5 the cut.

6 F. LIGHT FILTERING FABRICS

- 7 1. Equal to Phifer Shearweave 2410, Greenguard Certified.
- 8 a. Openness factor to be selected by architect from manufacturer's full range.
- 9 b. Beige/Pearl Gray. Color to be selected by architect from manufacturer's full range.

10 G. BLACKOUT FABRIC

- 11 1. N/A

12 H. FASCIA

- 13 1. To be selected from manufacturer's full range.

14

15 I. HEM BAR

- 16 1. Standard Sealed Hem Bar shall be a 1" wide by .1875" thick extruded aluminum bar enclosed on  
17 all sides in a thermally sealed pocket across the bottom of the shading fabric.

18

19 PART 3 - EXECUTION

20 3.01 EXAMINATION

- 21 A. Refuse delivery of any damaged packaging.
- 22 B. Ensure all parts match specified bill of materials and purchase order.

23 3.02 INSTALLATION

- 24 A. Install shades in windows level and plumb to provide smooth operation.
- 25 B. Install in accordance with manufacturer's product data and approved shop drawings
- 26 C. Field measurement and installation shall be performed by a factory-trained technician.

27 3.03 FIELD QUALITY CONTROL

- 28 A. Site test/Inspection
- 29 1. Examine substrate and conditions for installation. Do not commence installation until conditions  
30 are satisfactory. Commencement of installation indicates acceptance of site conditions by  
31 Contractor. Notify the Design Professional upon inspection when the project conditions are  
32 unacceptable for shade installation. "Beginning of installation" means acceptance of substrate and  
33 project conditions.

34 3.04 ADJUSTING

- 35 A. Adjust fabric on tube to prevent telescoping of fabric over time.

36 3.05 CLEANING

- 37 A. Touch up damaged finishes and repair minor damage in order to eliminate evidence of repair. Remove  
38 and replace work that cannot be satisfactorily repaired.

1           1. Clean exposed surfaces, including metal and shade fabric, using non-abrasive materials and  
2           methods recommended by the Shade Fabric Manufacturer. Remove and replace work that cannot  
3           be satisfactorily cleaned.

4    3.06 DEMONSTRATION

5           A. Demonstrate operation method and instruct Owner's personnel in the proper operation and maintenance of  
6           the window shade systems.

7    3.07 SCHEDULE OF OPENINGS

8           A. Exterior Opening in Breakroom 085. Provide (2) roller shades for this opening.

9           1. Install (1) roller shade from top of rough opening extending to top of light shelf. Install chain  
10           operation to floor.

11           2. Install (1) roller shade with top of roller shade aligning with top of light shelf extending to the sill.  
12           Install chain operation to floor.

13

14           Field verify openings.

15

16

END OF SECTION 12 24 13

17

Page Intentionally Left Blank

1

1 **SECTION 21 05 00**  
2 **COMMON WORK RESULTS FOR FIRE SUPPRESSION**

3  
4 **PART 1 - GENERAL**

5  
6 **SCOPE**

7 This section includes information common to two or more technical fire protection specification sections or items  
8 that are of a general nature, not conveniently fitting into other technical sections. Included are the following topics:

9 **PART 1 - GENERAL**

10 Scope  
11 Related Work Reference  
12 Reference Standards  
13 Quality Assurance  
14 Continuity of Existing Services  
15 Protection of Finished Surfaces  
16 Sleeves and Openings  
17 Sealing and Fire Stopping  
18 Off Site Storage  
19 Codes  
20 Design Criteria  
21 Certificates and Inspections  
22 Submittals  
23 Operating and Maintenance Instructions  
24 Training of Owner Personnel  
25 Record Drawings

26 **PART 2 - PRODUCTS**

27 Access Panels and Doors  
28 Identification  
29 Sealing and Fire Stopping

30 **PART 3 - EXECUTION**

31 Cutting and Patching  
32 Building Access  
33 Equipment Access  
34 Coordination  
35 Identification  
36 Sleeves and Openings  
37 Sealing and Fire Stopping

38  
39 **RELATED WORK**

40 This section applies to all Division 21 sections of fire suppression.

41  
42 **REFERENCE**

43 Applicable provisions of Division 1 govern work under this section.

44  
45 **REFERENCE STANDARDS**

46 Abbreviations of standards organizations referenced in this and other sections are as follows:

47  
48 AGA American Gas Association  
49 ANSI American National Standards Institute  
50 ASME American Society of Mechanical Engineers  
51 ASPE American society of Plumbing Engineers  
52 ASTM American Society for Testing and Materials  
53 AWWA American Water Works Association  
54 AWS American Welding Society

1	CGA	Compressed Gas Association
2	CS	Commercial Standards, Products Standards Sections, Office of Engineering Standards Service, NBS
3	EPA	Environmental Protection Agency
4	FM	FM Global
5	FS	Federal Specifications, Superintendent of Documents, U.S. Government Printing Office
6	IAPMO	International Association of Plumbing & Mechanical Officials
7	IEEE	Institute of Electrical and Electronics Engineers
8	ISA	Instrument Society of America
9	DSPS	State of Wisconsin Dept. of Safety and Professional Services
10	MCA	Mechanical Contractors Association
11	MICA	Midwest Insulation Contractors Association
12	MSS	Manufacturer's Standardization Society of the Valve & Fitting Industry, Inc.
13	NBS	National Bureau of Standards
14	NEC	National Electric Code
15	NEMA	National Electrical Manufacturers Association
16	NFPA	National Fire Protection Association
17	STI	Steel Tank Institute
18	UL	Underwriters Laboratories Inc.

19

**20 QUALITY ASSURANCE**

21 Substitution of Materials: Refer to Section GC - General Conditions of the Contract, Equals and Substitutions.

22

23 All products and materials used are to be new, undamaged, clean and in good condition. Existing products and  
24 materials are not to be reused unless specifically indicated.

25

26 Where equipment or accessories are used which differ in arrangement, configuration, dimensions, ratings, or  
27 engineering parameters from those indicated on the contract documents, the contractor is responsible for all costs  
28 involved in integrating the equipment or accessories into the system and for obtaining the intended performance  
29 from the system into which these items are placed.

30

**31 PROTECTION OF FINISHED SURFACES**

32 Refer to Division 1, General Requirements, Protection of Finished Surfaces.

33

**34 SLEEVES AND OPENINGS**

35 Refer to Division 1, General Requirements, Sleeves and Openings.

36

**37 SEALING AND FIRESTOPPING**

38 Sealing and firestopping of sleeves/openings between piping, etc. and the sleeve or structural opening shall be the  
39 responsibility of the contractor whose work penetrates the opening. The contractor responsible shall hire individuals  
40 skilled in such work to do the sealing and fireproofing. Provide all fire stopping of fire rated penetrations and  
41 sealing of smoke rated penetrations in compliance with section 07 84 00 Fire Stopping.

42

**43 OFF SITE STORAGE**

44 Prior approval by DFD and the A/E will be needed. The contractor shall submit Storage Agreement Form AD-BDC-  
45 74 to DFD for consideration of off site materials storage. Generally, sleeves, pipe/pipe fittings and similar rough-in  
46 material will not be accepted for off site storage. No material will be accepted for off site storage unless shop  
47 drawings for the material have been approved.

48

**49 CODES**

50 Comply with requirements of Wisconsin Administrative Code, Dept. of Safety and Professional Services, NFPA  
51 Standards and local Fire Chief or Fire Marshal (AHJ, Authority Having Jurisdiction) regarding design, materials and  
52 installation.

53

**54 DESIGN CRITERIA**

2

3 Bid No. 318045

Common Work Results for Fire Suppression

4

210500-2



1

1 Design fire protection systems in accordance with codes, standards and regulations noted above.

2

3 The automatic sprinkler system for office areas, conference/meeting rooms, toilet rooms, lobby corridors and similar  
4 spaces shall be designed to provide a minimum density of 0.10 gpm/sq. ft. over the hydraulically most remote 1,500  
5 sq. ft. using ½", 165 degree F. rated quick response sprinklers, while allowing a 250 gpm hose stream allowance.

6

7 The automatic sprinkler system for mechanical rooms, storage rooms, laundry rooms and similar spaces shall be  
8 designed to provide a minimum density of 0.15 gpm/sq. ft. over the hydraulically most remote 1,500 sq. ft. using  
9 ½", 225 degree F. rated quick response sprinklers, while allowing a 250 gpm hose stream allowance.

10

11

12

13 **CERTIFICATES AND INSPECTIONS**

14 Refer also to Division 1, General Conditions, Permits, Regulations, Utilities and Taxes.

15

16 Obtain and pay for all required State or local installation inspections except those provided by the  
17 Architect/Engineer . Deliver originals of NFPA test certificates and test reports to the Dane County construction  
18 representative. Include copies of the certificates and reports in the Operating and Maintenance Instructions.

19

20 **SUBMITTALS**

21 Refer to Division 1.

22

23 Not more than two weeks after award of contract but before any shop drawings are submitted, contractor to submit  
24 the following fire protection system data sheet. List piping material types, ASTM number, schedule or pressure  
25 class, joint type, manufacturer and model number where appropriate. List valves, specialties and equipment with  
26 manufacturer model number. The approved fire protection system data sheet(s) will be made available to the  
27 Owners project representative for their use on this project.

28

29 **FIRE PROTECTION SYSTEM DATA SHEET**

Item	Pipe Service/Sizes	Manufacturer/Model No.	Remarks
Pipe			
Fittings			
Hangers & Supports			
Sprinkler Heads			
Valves			

36

37

38 Shop drawing submittals are to be bound, labeled, contain the project manual cover page and a material index list  
39 page showing item designation, manufacturer and additional items supplied with the installation. Submit for all  
40 equipment and systems as indicated in the respective specification sections, marking each submittal with that  
41 specification section number. Mark general catalog sheets and drawings to indicate specific items being submitted  
42 and proper identification of equipment by name and/or number, as indicated in the contract documents. Include  
43 wiring diagrams of electrically powered equipment.

44

45 Submittals shall be sent to the local Fire Chief or Fire Marshal for review prior to the Architect/Engineer. Include  
46 copy of all review/approval letters in submission to Architect/Engineer.

47

48 Submit plans indicating water supply location and size, piping layout and size, sprinkler locations and type, hanger  
49 locations and type, equipment locations and type, valve locations and type, occupancy classes, hydraulic reference  
50 points, design areas and discharge densities.

51

52 Submit hydraulic calculations for water supply and sprinkler systems. Include summary sheet and detailed work  
53 sheets. Describe characteristics of water supply and location of effective point used in calculations. Include graph  
54 illustration of water supply, hose demand, sprinkler demand and in-rack sprinkler demand.

2

1

1

2 Submit sufficient quantities of data sheets and shop drawings to allow the following distribution:

- 3 1\* Operating and Maintenance Manuals
- 4 2\* Dane County Public Works 1 copy
- 5 3\* Dane County Facilities Management 1 copy
- 6 4\* Architect/Engineer 1 copy
- 7 5\* Local Fire Chief or Marshal 1 copy

8

9 **OPERATING AND MAINTENANCE INSTRUCTIONS**

10 All operations and maintenance data shall comply with the submission and content requirements specified under  
11 section GENERAL REQUIREMENTS.

12

13 In addition to the general content specified under GENERAL REQUIREMENTS supply the following additional  
14 documentation:

- 15 6\* Copies of all approved submittals along with approval letters.
- 16 7\* Manufacturer's wiring diagrams for electrically powered equipment.
- 17 8\* Records of tests performed to certify compliance with system requirements.
- 18 9\* Certificates of inspection by regulatory agencies.
- 19 10\* Parts lists for equipment and specialties.
- 20 11\* Manufacturers installation, operation and maintenance recommendations for equipment and specialties.
- 21 12\* Valve schedules
- 22 13\* Warranties
- 23 14\* Additional information as indicated in the technical specification sections

24

25 **TRAINING OF OWNER PERSONNEL**

26 Instruct Owner's personnel in the proper operation, maintenance and testing of systems and equipment provided as  
27 part of this project. Include not less than 2 hours of instruction, using the Operating and Maintenance manuals and  
28 record drawings during this instruction. Demonstrate testing, startup and shutdown procedures for all equipment.  
29 All training to be during normal working hours. Video record all instructions and provide Owner with copy.

30

31 **RECORD DOCUMENTS**

32 Refer to Division 1, General Requirements, Record Documents.

33

34 In addition to the data indicated in the General Requirements, maintain fire protection layout record drawings and  
35 hydraulic calculations on originals prepared by the installing contractor/subcontractor. Include copies of these  
36 record drawings and calculations with the Operating and Maintenance manuals.

37

38 **PART 2 - PRODUCTS**

39

40 **ACCESS PANELS AND DOORS**

41

42 LAY-IN CEILINGS:

43 Removable lay-in ceiling tiles in 2 X 2 foot or 2 X 4 foot configuration provided under Division 09 are sufficient; no  
44 additional access provisions are required unless specifically indicated.

45

46 CONCEALED SPLINE CEILINGS:

47 Removable sections of ceiling tile held in position with metal slats or tabs compatible with the ceiling system used  
48 will be provided under Division 09.

49

50 METAL PAN CEILINGS:

51 Removable sections of ceiling tile held in position by a pressure fit will be provided under Division 09.

52

53 PLASTER WALLS AND CEILINGS:

54 16 gauge frame with not less than a 20 gauge hinged door panel, prime coated steel for general applications,  
55 stainless steel for use in toilets, showers, and similar wet areas, concealed hinges, screwdriver operated cam latch for

2

4

1 general applications, key lock for use in public areas, UL listed for use in fire rated partitions if required by the  
 2 application. Use the largest size access opening possible, consistent with the space and the equipment needing  
 3 service; minimum size is 12" by 12".

#### 4 **IDENTIFICATION**

##### 5 **STENCILS:**

6 Not less than 1/2" high letters for pipe sizes 1" through 2-1/2" and 1 inch high letters/numbers for pipe sizes 3" and  
 7 above for marking pipe and equipment. Apply flow arrows to piping.  
 8

##### 9 **ADHESIVE LABELS:**

10 Pressure-sensitive, adhesive backed, vinyl pipe markers with applicable labeling, 3/4" min. size for lettering and  
 11 surrounding tape on both ends. With flow arrows on piping. Conforming to ANSI, ANSI and NFPA standards. Seton  
 12 Opti-Code, MSI, Brady or approved equal. Clean piping before application.  
 13

##### 14 **SNAP-AROUND MARKERS:**

15 One-piece, pre-formed, vinyl construction, snap-around or strap-around pipe markers with applicable labeling, 3/4"  
 16 min. size for lettering. Provide nylon ties on each end of pipe marker. Seton Setmark or approved equal.  
 17

##### 18 **SIGNS:**

19 Metal construction, baked porcelain enamel finish signs, sizes conforming to NFPA no. 13 and 7-1.2, with holes and  
 20 s-hooks/chains for hanging or securing. With applicable labeling. MSI, Seton, W.H. Brady or equal.  
 21

##### 22 **ENGRAVED NAME PLATES:**

23 White letters on a black background, 1/16 inch thick plastic laminate, beveled edges, screw mounting, Setonply  
 24 Style 2060 by Seton Name Plate Company or Emedolite Style EIP by EMED Co., or equal by W. H. Brady.  
 25

##### 26 **VALVE TAGS:**

27 Round brass tags with 1/2 inch numbers, 1/4 inch system identification abbreviation, 1-1/4 inch minimum diameter,  
 28 with brass jack chains with brass "S" hooks or one piece nylon ties around the valve stem, available from EMED  
 29 Co., Seton Name Plate Company, MSI or W. H. Brady.  
 30

#### 31 **SEALING AND FIRE STOPPING**

##### 32 **FIRE AND/OR SMOKE RATED PENETRATIONS:**

33 Manufacturers: 3M, Hilti, STI/SpeSeal, Tremco, or approved equal.  
 34

35 All fire stopping systems shall be provided by the same manufacturer.  
 36

37 Fire stop systems shall be UL listed or tested by an independent testing laboratory approved by the Department of  
 38 Industry, Labor, and Human Relations/Dept. of Commerce.  
 39

40 Submittals: Contractor shall submit product data for each firestop system. Submittals shall include product  
 41 characteristics, performance and limitation criteria, test data, MSDS sheets, installation details and procedures for  
 42 each method of installation applicable to this project. For non-standard conditions where no UL tested system  
 43 exists, submit manufacturer's drawings for UL system with known performance for which an engineering judgement  
 44 can be based upon.  
 45

46 Use a product that has a rating not less than the rating of the wall or floor being penetrated. Reference architectural  
 47 drawings for identification of fire and/or smoke rated walls and floors.  
 48

49 Use firestop putty, caulk sealant, intumescent wrapstrips, intumescent firestop collars, firestop mortar, or a  
 50 combination of these products to provide a UL listed system for each application required for this project. Provide  
 51 mineral wood backing where specified in manufacturer's application detail.  
 52

##### 53 **NON-RATED PENETRATIONS:**

##### 54 **Pipe Penetrations:**

1

1 At pipe penetrations of non-rated interior partitions, floors and exterior walls above grade, use urethane caulk in  
2 annular space between pipe insulation and sleeve. For non-rated drywall, plaster or wood partitions where sleeve is  
3 not required, use urethane caulk in annular space between pipe insulation and wall material.

4

5

6

## PART 3 - EXECUTION

7

### CUTTING AND PATCHING

9 Refer to Division 1, General Requirements, Cutting and Patching.

10

### BUILDING ACCESS

12 Arrange for the necessary openings in the building to allow for admittance of all apparatus. When the building  
13 access was not previously arranged and must be provided by this contractor, restore any opening to its original  
14 condition after the apparatus has been brought into the building.

15

### EQUIPMENT ACCESS

17 Install all piping, conduit and accessories to permit access to equipment for maintenance and service. Coordinate  
18 the exact location of wall and ceiling access panels and doors with the General Prime Contractor, making sure that  
19 access is available for all equipment and specialties. Access doors in general construction are to be furnished by the  
20 Fire Protection Contractor and installed by the General Prime Contractor.

21

22 Provide color coded thumb tacks or screws, depending on the surface, for use in accessible ceilings which do not  
23 require access panels.

24

### COORDINATION

26 Coordinate all work with other contractors prior to installation. Any work that is not coordinated and that interferes  
27 with other contractor's work shall be removed or relocated at the installing contractor's expense.

28

29 Verify that all devices are compatible for the type of construction and surfaces on which they will be used.

30

### IDENTIFICATION

32 Identify equipment in mechanical equipment rooms by stenciling equipment number and service with one coat of  
33 black enamel against a light background or white enamel against a dark background. Use a primer where necessary  
34 for proper paint adhesion.

35

36 Where stenciling is not appropriate for equipment identification, engraved name plates may be used.

37

38 Identify interior piping mains not less than once every 25 feet, not less than once in each room, adjacent to each  
39 access door or panel, and on both sides of the partition where exposed piping passes through walls or floors. Place  
40 flow directional arrows at each pipe identification location. Use one coat of black enamel against a light background  
41 or white enamel against a dark background, or approved pipe marking label systems, or provide snap-around type  
42 pipe markers as specified in Part 2 – Products.

43

44 Identify valves with signs per NFPA rulings.

45

46 Provide hydraulic design information sign of permanently marked weatherproof metal or engraved nameplate  
47 material. Secure to alarm valve with brass chain. Information to include location of the design areas, discharge  
48 densities, required flow and residual pressure at the base of riser, hose stream demand and sprinkler demand.

49

### SLEEVES AND OPENINGS

51 Provide galvanized sheet metal sleeves for fire rated pipe penetrations through interior and exterior walls to provide  
52 a backing for sealant or firestopping. Patch wall around sleeve to match adjacent wall construction and finish.  
53 Grout area around sleeve in masonry construction. In finished spaces where pipe penetration through wall is  
54 exposed to view, sheet metal sleeve shall be installed flush with face of wall. In existing poured concrete walls  
55 where penetration is core drilled, pipe sleeve is not required. Grout holes directly around steel pipe.

56

2

3 Bid No. 318045

Common Work Results for Fire Suppression

4

210500-6

1

1 Pipe sleeves are not required in interior non-rated drywall, plaster, or wood partitions and sleeves are not required in  
2 existing poured concrete walls where penetrations are core drilled.

3

4 Pipe sleeves in new poured concrete construction shall be Schedule 40 steel pipe (size to allow insulated pipe to run  
5 thru sleeve), cast in place.

6

7 In all piping floor penetrations, fire rated and non-fire rated top of sleeve shall extend 1 inch above the adjacent  
8 finished floor. In existing floor penetrations, core drill sleeve opening large enough to insert schedule 40 sleeve and  
9 grout area around sleeve with hydraulic setting, non-shrink grout. If the pipe penetrating the sleeve is supported by  
10 a pipe clamp resting on the sleeve, weld a collar or struts to the sleeve that will transfer the weight to existing floor  
11 structure.

12

13 **SEALING AND FIRE STOPPING**

14 **FIRE AND/OR SMOKE RATED PENETRATIONS:**

15 Provide all fire stopping of fire rated penetrations and sealing of smoke rated penetrations in compliance with  
16 section 07 84 00 Fire Stopping.

17

18 **NON-RATED PARTITIONS:**

19 At all interior partitions and exterior walls, pipe penetrations are required to be sealed. Apply sealant to both sides of  
20 the penetration in such a manner that the annular space between the pipe sleeve or cored opening and the pipe or  
21 insulation is completely blocked.

22

23

24

END OF SECTION

2

3 Bid No. 318045

4

Common Work Results for Fire Suppression

210500-7

Page Intentionally Left Blank



1  
2 Fasteners depending on soft lead for holding power or requiring explosive powder actuation will not be accepted.

3  
4 Support apparatus and material under all conditions of operation, variations in installed and operating weight of  
5 equipment and piping, to prevent excess stress, and allow for proper expansion and contraction.

6  
7 **SHOP DRAWINGS**

8 Schedule all hanger and support devices indicating attachment method and type of device for each pipe size and type  
9 of service. Provide details on the working drawings submitted for approval with all pertinent information listed.

10  
11 **DESIGN CRITERIA**

12 Materials and application of pipe hangers and supports shall be in accordance with MSS SP-58 Pipe Hangers and  
13 Supports – Materials, Design, Manufacture, Selection, Application and Installation unless noted otherwise.

14 Materials and application of pipe hangers and supports shall be in accordance with NFPA rulings and be UL/FM  
15 listed and approved.

16  
17 Piping connected to pumps, compressors, or other rotating or reciprocating equipment is to have vibration isolation  
18 supports for a distance of one hundred pipe diameters or three supports away from the equipment, whichever is  
19 greater. Standard pipe hangers/supports as specified in this section are required beyond the 100 pipe diameter/3  
20 support distance.

21  
22  
23 **PART 2 - PRODUCTS**

24  
25 **MANUFACTURERS**

26 B-Line, Anvil, Erico, Tolco, Afcon, Roof Products & Systems or approved equal.

27  
28 **STRUCTURAL SUPPORTS**

29 Provide all supporting steel required for the installation of mechanical equipment and materials, including angles,  
30 channels, beams, etc. to suspended or floor supported tanks and equipment. All of this steel may not be specifically  
31 indicated on the drawings.

32  
33 **PIPE HANGERS AND SUPPORTS**

34 **HANGERS FOR PIPE SIZES 1/2" THROUGH 4":**

35 Carbon steel, adjustable swivel ring with 3/8" min. UL/FM approved hanger rods. B-Line B3170NF, Anvil 69 or 70.

36 Carbon steel, adjustable clevis, standard, with UL/FM approved size hanger rods. B-Line B3100, Anvil 260.

37  
38 **HANGERS FOR PIPE SIZES 4" THROUGH 8":**

39 Carbon steel adjustable swivel ring with 1/2" min. UL/FM approved hanger rods. B-Line B3170NF, Anvil 69 or 70.

40 Carbon steel, adjustable clevis, standard with UL/FM approved size hanger rods. B-Line B3100, Anvil 260.

41  
42 **HANGERS FOR PIPE SIZES 10" and UP**

43 Carbon steel, adjustable clevis, standard with UL/FM approved size hanger rods. B-Line B3100, Anvil 260.

44  
45 **MULTIPLE OR TRAPEZE HANGERS:**

46 Manufactured steel channel system with manufacturers slotted interlocking pipe clamps with screw/nut securing and  
47 threaded hanger rods or steel channels with welded spacers and threaded hanger rods.

48  
49 **WALL SUPPORT:**

50 Carbon steel welded bracket with hanger. B-Line 3060 Series, Anvil 190 Series.

51 Steel channels with pipe clamps.

52  
53 **VERTICAL SUPPORT:**

54 Carbon steel riser clamp. B-Line B3373, Anvil 261 for above floor use.

1 Bid No. 318045

Supports and Anchors

21 05 29-2



1  
2 FLOOR SUPPORT:  
3 Carbon steel pipe saddle, stand and bolted floor flange. B-Line B3088T/B3093.

4  
5 COPPER PIPE SUPPORTS:  
6 All supports, fasteners, clamps, etc. directly connected to copper piping shall be copper plated or polyvinylchloride  
7 coated. Where steel channels are used, provide flexible elastomeric/thermoplastic isolation cushion material to  
8 completely encircle the piping and avoid contact with the channel or clamp, equal to B-Line B1999 Vibra Cushion  
9 or provide manufacturers clamp and cushion assemblies, B-Line BVT series, Grinnell PS 1400 series.

10  
11 **PIPE HANGER RODS**

12 STEEL HANGER RODS:  
13 Threaded both ends, threaded one end, or continuous threaded, complete with adjusting and lock nuts.  
14  
15 Size rods for individual hangers and trapeze support as indicated in the following schedule.

16  
17 

<u>Pipe Size</u>	<u>Diam. Of Rod</u>
18 Up to and	
19 Including 4"	3/8" or 9.5mm min.
20	
21 5",6" and 8"	1/2" or 12.7mm min.
22	
23 10" and 12"	5/8" or 15.9mm min.

24  
25 **BEAM CLAMPS**

26 MSS SP-58 Types 19 & 23 malleable black iron clamp for attachment to beam flange to 0.62 inches thick with a  
27 retaining ring and threaded rod of 3/8, 1/2, and 5/8 inch diameter. Furnish with a hardened steel cup point set screw.  
28 B-Line B3036L/B3034, Anvil 86/92.

29  
30 MSS SP-58 Type 28 or Type 29 forged steel jaw type clamp with a tie rod to lock clamp in place, suitable for rod  
31 sizes to 1-1/2 inch diameter. B-Line B3054, Anvil 228.

32  
33 **CONCRETE INSERTS**

34 **POURED IN PLACE:**  
35 MSS SP-58 Type 18 wedge type to be constructed of a black carbon steel body with a removable malleable iron nut  
36 that accepts threaded rod to 7/8 inch diameter. Wedge design to allow the insert to be held by concrete in  
37 compression to maximize the load carrying capacity. B-Line B2505, Anvil 281.

38  
39 MSS SP-58 Type 18 universal type to be constructed of black malleable iron body with a removable malleable iron  
40 nut that accepts threaded rod to 7/8 inch diameter. B-Line B3014N, Anvil 282.

41  
42 **DRILLED FASTENERS:**

43  
44 **CONCRETE CONSTRUCTION**

45 Carbon steel expansion anchors, vibration resistant, with ASTM B633 zinc plating. Use drill bit of same  
46 manufacturer as anchor. Hilti, Rawl, Redhead.

47  
48 **WOOD CONSTRUCTION**

49 Side or bottom mount lag thread by rod thread one piece hanger attachment installed per the Manufacturers standard  
50 and carrying capacity limit. Powers Fastener Vertigo, Erico Hangermate or equal.

51  
52 **ANCHORS**

53 Use welding steel shapes, plates, and bars to secure piping to the structure.

1  
2  
3  
4 **PART 3 - EXECUTION**

5 **INSTALLATION**

6 Size, apply and install supports and anchors in compliance with manufacturers recommendations.

7 Install supports to provide for free expansion of the piping system. Support all piping from the structure using  
8 concrete inserts, beam clamps, ceiling plates, wall brackets, or floor stands. Fasten ceiling plates and wall brackets  
9 securely to the structure and test to demonstrate the adequacy of the fastening.

10  
11 Coordinate hanger and support installation to properly group piping of all trades.

12  
13 Where piping can be conveniently grouped to allow the use of trapeze type supports, use standard structural shapes  
14 or continuous insert channels for the supporting steel. Where continuous insert channels are used, pipe supporting  
15 devices made specifically for use with the channels may be substituted for the specified supporting devices provided  
16 that similar types are used and all data is submitted for prior approval.

17  
18 Perform welding in accordance with standards of the American Welding Society.

19  
20 **HANGER AND SUPPORT SPACING**

21  
22 Use hangers with minimum vertical adjustment.

23  
24 Where several pipes can be installed in parallel and at the same elevation, provide multiple or trapeze hangers.

25  
26 Support riser piping independently of connected horizontal piping.

27  
28 Adjust hangers to obtain the slope specified in the piping section of these specifications.

29  
30 Space hangers for pipe as follows:

<u>Pipe Material</u>	<u>Pipe Size</u>	<u>Max. Horiz. Spacing</u>	<u>Max. Vert. Spacing</u>
Copper	3/4" through 1"	8'-0"	10'-0"
Copper	1-1/4" through 1-1/2"	10'-0"	10'-0"
Copper	2" through 3"	12'-0"	10'-0"
Copper	3-1/2" through 8"	15'-0"	10'-0"
Steel	1" through 1-1/4"	12'-0"	15'-0"
Steel	1-1/2" through 8"	15'-0"	15'-0"

31  
32  
33  
34  
35  
36  
37  
38  
39 Unsupported length from the last hanger and an end sprinkler for steel piping systems shall be as follows:

40 1" piping	Not greater than 36"
41 1-1/4" piping	Not greater than 48"
42 1-1/2" piping	Not greater than 60"
43 or larger.	

44  
45 **RISER CLAMPS**

46 Support vertical piping with clamps secured to the piping and resting on the building structure or secured to the  
47 building structure below at each floor. Use method of securing the vertical risers to the building structure below in  
48 stairwell locations.

49  
50 **ANCHORS**

51 Install where indicated on the drawings and details. Where not specifically indicated, install anchors at ends of  
52 principal pipe runs and at intermediate points in pipe runs. Make provisions for preset of anchors as required to  
53 accommodate both expansion and contraction of piping.

1  
2

END OF SECTION

Page Intentionally Left Blank



1 **REFERENCE** **RFB318045**

2 Applicable provisions of Division 1 govern work under this section.

3

4 **REFERENCE STANDARDS**

5 ANSI A21.4

6 ANSI A21.11

7 ANSI A21.51

8 ANSI B16.1 Cast Iron Pipe Flanges and Flanged Fittings

9 ANSI B16.3 Malleable and Ductile Iron Threaded Fittings

10 ANSI B16.4 Cast Iron Threaded Fittings

11 ANSI B16.5 Pipe Flanges and Flanged Fittings

12 ANSI B16.9 Factory Made Wrought Steel Butt-weld Fittings

13 ANSI B16.11 Forged Steel Fittings, Socket Welded and Threaded

14 ANSI B16.18 Cast Bronze Solder Joint Pressure Fittings

15 ANSI B16.22 Wrought Copper and Wrought Copper Alloy Solder Joint Pressure Fittings

16 ANSI B16.29 Wrought Copper and Wrought Copper Alloy Solder Joint Drainage Fittings - DWV

17 ASTM A53 Pipe, Steel, Black and Hot-Dipped, Zinc Coated Welded and Seamless

18 ASTM A105 Forgings, Carbon Steel, for Piping Components

19 ASTM A126 Gray Cast Iron Castings for Valves, Flanges, and Pipe Fittings

20 ASTM A135 Electric Resistance Welded Steel Pipe

21 ASTM A181 Forgings, Carbon Steel for General Purpose Piping

22 ASTM A234 Pipe Fittings of Wrought Carbon Steel and Alloy Steel for Moderate and Elevated Temperatures

23 ASTM A536 Ductile Iron Castings

24 ASTM A795 Black and Hot Dipped Zinc Coated (Galvanized) Welded and Seamless Steel Pipe for Fire Protection

25 Use

26 ASTM B88 Seamless Copper Water Tube

27 AWS A5.8 Brazing Filler Metal

28 AWS D10.9 Qualification of Welding Procedures and Welders for Piping and Tubing, Level AR3

29 NFPA 13 Installation of Sprinkler Systems. (Latest prevailing edition)

30 NFPA 14 Installation of Standpipe and Hose Systems. (Latest prevailing edition)

31 UL Underwriters' Laboratories Listing

32 FM Factory Mutual Approval

33

34 **SHOP DRAWINGS**

35 Schedule from the contractor indicating the ANSI/ASTM specification number of the pipe being proposed along  
36 with its type and grade, if known at the time of submittal, and sufficient information to indicate the type and rating  
37 of fittings for each service.

38

39 **QUALITY ASSURANCE**

40

41 Substitution of Materials: Refer to Section GC – General Conditions of the Contract, Equals and Substitutions.

42 Order steel pipe with each length marked with the name or trademark of the manufacturer and type of pipe; with  
43 each shipping unit marked with the purchase order number, metal or alloy designation, temper, size, and name of  
44 supplier.

45

46 Any installed material not meeting the specification requirements must be replaced with material that meets these  
47 specifications without additional cost to the Owner.

48

49 **DELIVERY, STORAGE, AND HANDLING**

50 Promptly inspect shipments to ensure that the material is undamaged and complies with specifications.

51

1 Cover pipe to prevent corrosion or deterioration while allowing sufficient ventilation to avoid condensation. Do not  
2 store materials directly on grade. Protect pipe, tube, and fitting ends so they are not damaged. Where end caps are  
3 provided or specified, take precautions so the caps remain in place. Protect fittings, flanges, and unions by storage  
4 inside or by durable, waterproof, above ground packaging.

5  
6 Offsite storage agreements will not relieve the contractor from using proper storage techniques.

7  
8 Storage and protection methods must allow inspection to verify products.

9  
10 **DESIGN CRITERIA**

11 Use only new material, free of defects, rust and scale, and meeting the latest revision of ASTM specifications as  
12 listed in this specification.

13  
14 Construct all piping systems for the highest pressures and temperatures in the respective system but not less than  
15 175 psig.

16  
17 Where weld fittings are used, use only long radius elbows having a centerline radius of 1.5 pipe diameters.

18  
19 Where mechanical grooved fittings are used, use only ASTM standard radius fittings, short radius grooved fittings  
20 are not allowed.

21  
22 Where ASTM A53 or A795 type F pipe is specified, grade A type E or S, or grade B type E or S may be substituted  
23 at Contractor's option. Where ASTM A135 grade A pipe is specified, grade B pipe may be substituted at  
24 Contractor's option. Where the grade or type is not specified, Contractor may choose from those commercially  
25 available.

26  
27 Where ASTM B88, type L H (drawn) temper copper tubing is specified, ASTM B88, type K H (drawn) temper  
28 copper tubing may be substituted at Contractor's option.

29  
30 **WELDER QUALIFICATIONS**

31 Welding procedures, welders, and welding operators for all building service piping to be in accordance with certified  
32 welding procedures of the National Certified Pipe Welding Bureau and Section 927.5 of ASME B31.9 Building  
33 Services Piping or AWS 10.9 Qualification of Welding Procedures and Welders for Piping and Tubing. Before any  
34 metallic welding is performed, Contractor to submit his Standard Welding Procedure Specification together with the  
35 Procedure Qualification Record as required by Section 927.6 of ASME B31.9 Building Services Piping.

36  
37  
38 The Architect or Engineer reserves the right to test the work of any welder employed on the project, at the Owner's  
39 expense. If the work of the welder is found to be unsatisfactory, the welder shall be prevented from doing further  
40 welding on the project and all defective welds replaced.

41  
42  
43 **PART 2 - PRODUCTS**

44  
45 **FIRE SUPPRESSION PIPING**

46 **STEEL PIPE:**

47 Black steel pipe welded and seamless, Type F, Grade A, ASTM A53; black welded and seamless steel pipe for fire  
48 protection use, Type F, ASTM A795; electric resistance welded steel pipe, Grade A, ASTM A135.

49  
50 **Pipe wall Thickness:**

51 Threaded pipe shall have a minimum wall thickness of schedule 40.

52 All other pipe shall have a minimum wall thickness of schedule 10.

1 Piping 2" and under shall be minimum schedule 40 unless stated otherwise herein.

2  
3 RFB318045

4  
5 Fittings: Cast iron threaded fittings, Class 125 or 250, ASTM A126/ANSI B16.4. Malleable and ductile iron threaded  
6 fittings, Class 150 or 300, ASTM A197/ANSI B16.3. Standard weight seamless carbon steel weld fittings, ASTM  
7 A234 grade, ANSI B16.9. Mechanical grooved fittings with EPDM gaskets, ASTM A536 ductile iron, ASTM A47  
8 malleable iron or ASTM A53 fabricated steel. For wet pipe systems mechanical tee fittings with full iron back equal  
9 to Grinnell Figure 730 will be allowed only as needed for connection to existing systems. Outlets for drypipe and  
10 preaction systems shall be mechanical tees. Mechanical tees with U-bolt back or other fastening means are not allowed.

11  
12  
13 Welding Materials: Comply with Section II, Part C, ASME Boiler and Pressure Vessel Code for welding materials.

14  
15 Finish: Hot dipped zinc coated (galvanized) finish on piping and fittings shall be used in drypipe and pre-action  
16 systems, piping exposed to weather and piping exposed to corrosive environments where indicated. Thread or grooved  
17 hot dipped zinc coated pipe ends for fitting connections. Indoor dry standpipe systems supplied by a Fire Dept.  
18 connection only may be black steel piping and fittings.

19  
20 No exposed CPVC piping material is allowed.

21  
22 Plastic pipe and fittings will not be allowed for this project.

23  
24  
25  
26  
27  
28 **UNIONS AND FLANGES**

29 **2" AND SMALLER STEEL:**

30 ASTM A197/ANSI B16.3 malleable iron unions with brass seats. Use black malleable iron on black steel piping and  
31 galvanized malleable iron on galvanized steel piping. Grooved couplings may be used in lieu of unions.

32  
33 **2" AND SMALLER COPPER:**

34 ANSI B16.18 cast bronze union coupling or ANSI B15.24 Class 150 cast bronze flanges.

35  
36 **2-1/2" AND LARGER:**

37 ASTM A181 or A105, Class 150, grade 1 hot forged steel flanges of threaded, welding neck, or slip-on pattern on  
38 black steel and threaded only on galvanized steel. ANSI B16.1 or ANSI B16.5, Class 150 cast iron threaded flanges.  
39 Use raised face flanges ANSI B16.5 for mating with other raised face flanges or equipment with flat ring or full face  
40 gaskets. Use ANSI B16.1 flat face flanges with full face gaskets for mating with other flat face flanges on  
41 equipment.

42  
43 **2-1/2" AND LARGER COPPER:**

44 ANSI B16.24, Class 150 cast bronze flanges with raised face.

45  
46 **MECHANICAL GROOVED PIPE CONNECTIONS**

47 Mechanical grooved pipe couplings and fittings, ASTM F1476, as manufactured by Victaulic, Anvil, or Grinnell  
48 may be used with steel pipe. Mechanical grooved components and assemblies to be rated for minimum 175 psi  
49 working pressure unless noted otherwise.

50  
51 All mechanical grooved pipe material including gaskets, couplings, fittings and flange adapters shall be from the  
52 same manufacturer.



1  
2 Couplings and fittings to be malleable iron, ASTM A47, or ductile iron A536 with painted finish. Fittings used on  
3 galvanized steel pipe to have galvanized finish, ASTM A153.  
4  
5 Gaskets to be EPDM, ASTM D2000. Gaskets for dry systems to be flush seal design. Heat treated carbon steel oval  
6 neck track bolts and nuts, ASTM A-183, with zinc electroplated finish.  
7  
8 Flange adapters to be ductile iron, ASTM A536; except at lug type butterfly valves where standard threaded flanges  
9 shall be used.  
10  
11  
12 Credit for the inherent flexibility of mechanical grooved pipe connections when used for expansion joints or flexible  
13 connectors may be allowed upon specific application by the Contractor. Three flexible couplings at first three  
14 connection points both upstream and downstream of pumps may be used in lieu of flexible connectors. Request for  
15 expansion joints shall be made in writing and shall include service, location, line size, proposed application and  
16 supporting calculations for the intended service.  
17  
18 **SPRINKLER HEADS**  
19 Manufacturer: Sprinkler head model numbers establish type and style of head. Products of the following  
20 manufacturers determined to be equal by the Architect/Engineer will be accepted: Tyco, Reliable, Victaulic, Viking  
21 and Globe.  
22  
23 Standard coverage sprinkler heads are to be the basis for design unless noted otherwise on the plans or within these  
24 specifications.  
25  
26  
27  
28 Fusible link or glass bulb type, cast brass or bronze construction. Provide heads with nominal 1/2" or 17/32"  
29 discharge orifice except where greater than normal density requires large orifice.  
30  
31 Select fusible link or glass bulb temperature rating to not exceed maximum ambient temperature rating allowed  
32 under normal conditions at installed location. Provide ordinary temperature (155 to 165 degree) fusible link or glass  
33 bulb type except at skylights, sealed display windows, unventilated attics and roof spaces, over cooking equipment,  
34 adjacent to diffusers, unit heaters, uninsulated heating pipes or ducts, mechanical rooms, storage rooms, or where  
35 otherwise indicated.  
36  
37 Provide quantity of spare heads as noted below and 1 wrench for each type of head and each temperature range  
38 installed. Provide 6 spare heads per 300 or less installed heads, 12 per 1000 or less and 24 for more than 1000.  
39 Provide steel cabinet for storage of heads and wrenches. Provide an equal number of concealed cover plates and/or  
40 sprinkler escutcheons for each spare sprinkler head.  
41  
42  
43  
44 Quick Response Upright: Viking Microfast M (QR), brass finish.  
45  
46 Quick Response Vertical Sidewall: Viking Microfast M, chrome finish.  
47  
48 Quick Response Pendant: Viking Microfast M, chrome plated finish and escutcheon.  
49  
50 Quick Response Sidewall: Viking Microfast M, chrome plated finish and escutcheon.  
51  
52 Dry Pendant (Self-contained type): Viking Model C, brass finish with brass escutcheon.  
53

1 Dry Pendant (Self-contained type): Viking Model M (Quick Response), adjustable, recessed, with chrome  
2 escutcheon.  
3 RFB318045  
4 Dry Horizontal Sidewall (Self-contained type): Viking Model M (Quick response), adjustable, recessed, with  
5 chrome escutcheon.  
6  
7 Concealed sprinkler: Viking Mirage (Quick Response), with adjustable concealed cover plate. Cover plate finish to  
8 be selected by the Architect/Engineer from the manufacturer's standard finish selections.  
9

10 Pendant Security: Tyco Raven, Security pendent shall not have an exposed heat sensing element.  
11

12 Horizontal Sidewall Security: Tyco Raven, with sleeve, centering grommet and retainer flange. Security sidewall  
13 shall not have an exposed heat sensing element.  
14

15 **FLEXIBLE SPRINKLER DROP FITTINGS**

16 Manufacturers: FlexHead Industries, Victaulic or Viking.  
17

18 Corrugated Type 304 stainless steel hose with braided Type 304 stainless steel exterior cover, welded stainless steel  
19 or zinc plated steel inlet and outlet threaded fittings with EPDM seals. 175 PSI pressure rating. 225 °F temperature  
20 rating, 1" minimum internal hose diameter. 40" maximum hose length, straight or angle outlet configuration.  
21

22 Galvanized steel ceiling support bar and brackets selected to match project ceiling support system requirements. UL  
23 Listed and FM approved.  
24

25 Flexible drops are only allowed for use above fully accessible ACT ceilings.  
26  
27  
28  
29

30 **PRESSURE GAUGES**

31 Manufacturer: Ametek/U. S. Gauge Division, Ashcroft, Marsh, Taylor, H. O. Trerice, Weiss, Weksler.  
32

33 Cast aluminum, stainless steel, brass, polycarbonate or ABS case of not less than 3.5 inches in diameter, double  
34 strength glass window, black lettering on a white background, phosphor bronze bourdon tube with bronze bushings,  
35 recalibration from the front of the dial, 99% accuracy over the middle half of the scale, 98.5% accuracy over the  
36 remainder of the scale. Include bronze 3-way globe valve with plugged outlet for Fire Inspector's test gauge.  
37

38 **VALVES**

39 Manufacturers: Kennedy, Milwaukee, Nibco, Stockham, Victaulic, or Watts.  
40

41 **BALL VALVES:**

42 2" and smaller: Bronze, 2-piece, threaded or sweat ends, standard port, blowout proof stem, chrome plated ball,  
43 glass reinforced seats, UL approved @ 250 psi. Watts No. B-6000 UL.  
44

45 **GATE VALVES:**

46 2" and smaller: Outside screw and yoke gate valves, 175 psig, bronze body, bronze mounted, screwed bonnet, rising  
47 stem, solid wedge, with normally open tamper switch with double wire leads.  
48

49 2-1/2" and larger: Outside screw and yoke gate valves, 175 psig, cast iron body, bronze mounted, bolted bonnet,  
50 rising stem, solid wedge, with normally open tamper switch with double wire leads.  
51  
52

1  
2 **SUPERVISORY/TAMPER SWITCHES:**

3  
4 RFB318045

5 For O S & Y valve or butterfly valve installations, UL/FM listed/approved, to monitor position of valve, tamper  
6 resistant cover screws, single or double SPDT switch contacts, corrosion resistant, for indoor or outdoor use, NEMA  
7 4 & 6P enclosures.  
8  
9

10  
11  
12  
13  
14 **GENERALPART 3 - EXECUTION**

15  
16  
17 Install pipe fittings, and other fire suppression system components in accordance with reference standards,  
18 manufacturers recommendations and recognized industry practices.  
19

20 **PREPARATION**

21 Cut pipe ends square. Ream ends of piping to remove burrs. Clean scale and dirt from interior and exterior of each  
22 section of pipe and fitting prior to assembly.  
23

24 **ERECTION**

25 Install all piping parallel to building walls and ceilings and at heights which do not obstruct any portion of a  
26 window, doorway, stairway, or passageway. Where interferences develop in the field, offset or reroute piping as  
27 required to clear such interferences. Coordinate locations of fire protection piping with piping, ductwork, conduit  
28 and equipment of other trades to allow sufficient clearances. In all cases, consult drawings for exact location of pipe  
29 spaces, ceiling heights, ceiling grid layout, light fixtures and grilles before installing piping.  
30

31 Where copper or steel piping is embedded in masonry or concrete, provide protective sleeve covering of elastomeric  
32 pipe insulation.  
33

34 Provide 3/32" min. thickness steel nailing plates behind or on either side of piping where the possibility of  
35 penetration from nails or drywall screws exists.  
36

37 Maintain piping in clean condition internally during construction.  
38

39 Provide clearance for access to valves and piping specialties.  
40

41 Provide anchors, expansion joints, swing joints and/or expansion loops so that piping may expand and contract  
42 without damage to itself, equipment, or building.  
43

44 Install piping so that system can be drained. Where possible, slope to main drain valve. Slope dry pipe and pre-  
45 action systems subject to freezing at minimum 1/4"/10' on mains and 1/2"/10' on branches. Where piping not  
46 susceptible to freezing cannot be fully drained, install nipple and cap for drainage of less than 5 gallons or ball valve  
47 with hose thread outlet and cap for drainage over 5 gallons. Pipe main drain valve to grade or to air gap sewer  
48 receptor.  
49

50 Mitered ells, notched tees, and orange peel reducers are not acceptable. On threaded piping, bushings are not  
51 acceptable.  
52

1 Do not route piping within exterior walls.

2

3 Do not route piping through transformer vaults or above transformers, panelboards, or switchboards, including the  
4 required service space for this equipment, unless the piping is serving this equipment.

5

6

7 Install all valves and piping specialties, including items furnished by others, as specified and/or detailed. Provide  
8 access to valves and specialties for maintenance. Make connections to all equipment, fixtures and systems installed  
9 by others where same requires the piping services indicated in this section.

10

11 **COPPER PIPE JOINTS**

12 Remove all slivers and burrs remaining from the cutting operation by reaming and filing both pipe surfaces. Clean  
13 fitting and tube with metal brush, emery cloth or sandpaper. Remove residue from the cleaning operation and  
14 assemble joint to socket stop. Apply flame to fitting until brazing alloy melts when placed at joint. Wipe excess alloy  
15 from joint.

16

17

18

19 Make all welded joints by fusion welding in accordance with ASME Codes, ANSI B31, and State Codes where  
20 applicable. "Weldolets" and "Threadolets" may be used up to following sizes:

21

22	Maximum	
23	Weldolet/ Threadolet	Main Pipe
24	<u>Diameter</u>	<u>Diameter</u>
25	3/4"	1 1/4"
26	1"	1 1/2"
27	1 1/4"	2"
28	1 1/2"	2 1/2"
29	2"	3"
30	3"	4"
31	4"	6"
32	6"	8"

33

34

35 **THREADED PIPE JOINTS**

36 Use a thread lubricant or teflon tape when making joints; no hard setting pipe thread cement or caulking will be  
37 allowed.

38

39 **MECHANICAL GROOVED PIPE CONNECTIONS**

40 Use pipe factory grooved in accordance with the coupling manufacturer's specifications or field grooved pipe in  
41 accordance with the same specifications using specially designed tools available for the application. Lubricate pipe  
42 and coupling gasket, align pipe, and secure joint in accordance with the coupling manufacturer's specifications.

43

44 **UNIONS AND FLANGES**

45 Install a union, flange or grooved coupling combination at each connection to each piece of equipment and at other  
46 items which may require removal for maintenance, repair, or replacement. Where a valve is located at a piece of  
47 equipment, locate the flange or union or grooved coupling combination connections on the equipment side of the  
48 valve. Concealed unions, flanges or couplings are not acceptable.

49

50 **FLEXIBLE SPRINKLER DROP FITTINGS**

51 Install in accordance with manufacturer's installation instructions following minimum bend radii, maximum number  
52 of bends and bend distance from end requirements.

1  
2  
3  
4  
5  
6  
7  
8  
9  
10  
11  
12  
13  
14  
15  
16  
17  
18  
19  
20  
21  
22  
23  
24  
25  
26  
27  
28  
29  
30  
31  
32  
33  
34  
35  
36  
37  
38  
39  
40  
41  
42  
43  
44  
45  
46  
47  
48  
49  
50  
51

**PIPING SYSTEM LEAK TESTS**

Conduct pressure test with test medium of water. If leaks are found, repair the area with new materials and repeat the test; caulking will not be acceptable.

RFB318045

Test piping in sections or entire system as required by sequence of construction. Do not conceal pipe until it has been successfully tested. If required for the additional pressure load under test, provide temporary restraints at fittings or expansion joints. Entire test must be witnessed by the Division's representative.

Use clean water and remove air from the piping being tested where possible. Measure and record test pressure at the high point in the system.

Test system at 200 psi for 2 hours showing no leakage. Where system design is in excess of 150 psig, test at a pressure 50 psig above system design pressure.

All pressure tests are to be documented on NFPA Contractor's Material and Test Certificate forms.

**INSTALLATION**

Install fire protection system components in accordance with NFPA rulings, listings and manufacturers recommendations. Locate where accessible for servicing and replacement.

**Sprinkler Heads:** Locate sprinkler heads as indicated on fire protection plan and reflected ceiling plan maintaining minimum clearances from obstructions, ceilings and walls. Install sprinkler heads level in locations not subject to spray pattern interference. Provide fire sprinkler head installations below ductwork, soffits, etc. Sprinkler heads shall be located in the center of ceiling tiles, a one inch tolerance will be acceptable

**Switches:** Locate flow and pressure switches where indicated and where required to obtain specified zoning to isolate floors and major areas of floors. Provide valved test connection for flow switch adjacent to flow switch. Pipe to floor drain. Test flow switch to verify proper operation.

**Gauges:** Provide a valved pressure gauge in main fire protection riser, at the top of each piping riser, at inlet and outlet of pump and elsewhere as indicated.

**Valves:** Properly align piping before installation of valves. Do not support weight of piping system on valve ends. Mount valves in locations which allow access for operation, servicing and replacement. Install all valves with the stem in the upright or horizontal position. Valves installed with the stems down will not be accepted. Provide a riser shutoff valve and a capped hose thread drain valve at the bottom of each riser. Provide capped hose thread drain valves to allow draining of each portion of piping.

END OF SECTION

Page Intentionally Left Blank

1  
2  
3  
4  
5  
6  
7  
8  
9  
10  
11  
12  
13  
14  
15  
16  
17  
18  
19  
20  
21  
22  
23  
24  
25  
26  
27  
28  
29  
30  
31  
32  
33  
34  
35  
36  
37  
38  
39  
40  
41  
42  
43  
44  
45  
46  
47  
48  
49  
50  
51  
52  
53  
54

**SECTION 22 05 00**  
**COMMON WORK RESULTS FOR PLUMBING**

**PART 1 - GENERAL**

**SCOPE**

This section includes information common to two or more technical plumbing specification sections or items that are of a general nature, not conveniently fitting into other technical sections. Included are the following topics:

**PART 1 - GENERAL**

- Scope
- Reference
- Standards
- Quality Assurance
- Continuity of Existing Services
- Codes
- Certificates and Inspections
- Submittals
- Operating and Maintenance Data
- Training of Owner Personnel
- Record Drawings

**PART 2 - PRODUCTS**

- Identification
- Sealing and Fire Stopping
- Concrete Work

**PART 3 - EXECUTION**

- Demolition
- Cutting and Patching
- Building Access
- Equipment Access
- Coordination
- Identification
- Lubrication
- Training

**REFERENCE**

Applicable provisions of Division 1 govern work under this section.

This section applies to all Division 22 00 00 sections of plumbing.

**STANDARDS**

Abbreviations of standards organizations referenced in this and other sections are as follows:

- ABMA American Boiler Manufacturers Association
- ANSI American National Standards Institute
- ASME American Society of Mechanical Engineers
- ASPE American society of Plumbing Engineers
- ASSE American Society of Sanitary Engineering
- ASTM American Society for Testing and Materials
- AWS American Welding Society
- CS Commercial Standards, Products Standards Sections, Office of Eng. Standards Service, NBS
- EPA Environmental Protection Agency
- FS Federal Specifications, Superintendent of Documents, U.S. Government Printing Office
- IAPMO International Association of Plumbing & Mechanical Officials

- 1 MCA Mechanical Contractors Association
- 2 MICA Midwest Insulation Contractors Association
- 3 MSS Manufacturer's Standardization Society of the Valve & Fitting Industry, Inc.
- 4 NBS National Bureau of Standards
- 5 NEC National Electric Code
- 6 NEMA National Electrical Manufacturers Association
- 7 NFPA National Fire Protection Association
- 8 NSF National Sanitation Foundation
- 9 PDI Plumbing and Drainage Institute
- 10 UL Underwriters Laboratories Inc.

11

12 Standards referenced in this section:

- 13 ACI 614 Recommended Practice for Measuring, Mixing and Placing of Concrete
- 14 ASTM E814 Standard Test Method for Fire Tests of Through-Penetration Fire Stops
- 15 ASTM E84 Standard Test Method for Surface Burning Characteristics of Building Materials
- 16 D.O.T. Standard Specifications for Road and Bridge Construction, State of Wisconsin, Dept. of  
17 Transportation
- 18 UL1479 Fire Tests of Through-Penetration Firestops
- 19 UL723 Surface Burning Characteristics of Building Materials

20

## 21 **QUALITY ASSURANCE**

22 Substitution of Materials: Refer to Division 1 - Basic Requirements

23

24 All products and materials used are to be new, undamaged, clean and in good condition. Existing products  
25 and materials are not to be reused unless specifically indicated.

26

27 Where equipment or accessories are used which differ in arrangement, configuration, dimensions, ratings, or  
28 engineering parameters from those indicated on the contract documents, the contractor is responsible for all  
29 costs involved in integrating the equipment or accessories into the system and for obtaining the intended  
30 performance from the system into which these items are placed.

31

## 32 **CONTINUITY OF EXISTING SERVICES**

33 Do not interrupt or change existing services without prior written approval from the Owner's Project  
34 Representative. When interruption is required, coordinate scheduling of down-time with the Owner to  
35 minimize disruption to his activities.

36

## 37 **CODES**

38 Comply with requirements of Wisconsin Administrative Code.

39

## 40 **CERTIFICATES AND INSPECTIONS**

41 Refer also to Division 1.

42

43 Obtain and pay for all required City of Madison or State of Wisconsin installation inspections except those  
44 provided by the Architect/Engineer in accordance with Wis. Admin. Code Section ILHR 50.12. Deliver  
45 originals of these certificates to the Owner's Project Representative. Include copies of the certificates in the  
46 Operating and Maintenance Instructions.

47

## 48 **SUBMITTALS**

49 Refer to Division 1.

50

51 Not more than two weeks after award of contract but before any shop drawings are submitted, contractor to  
52 submit the following plumbing system data sheet. List piping material type for each piping service on the  
53 project, ASTM number, schedule or pressure class, joint type, manufacturer and model number where  
54 appropriate. List valves and specialties for each piping service, fixture and equipment with manufacturer and



1 model number. The approved plumbing system data sheet(s) will be made available to the Owner's Project  
2 Representative for their use on this project.

3

4 **PLUMBING SYSTEM DATA SHEET**

5 Item                      Pipe Service/Sizes                      Manufacturer/Model No.      Remarks

6 Pipe

7 Fittings

8 Unions

9 Valves:

10              Ball

11              Check

12 Pipe Specialties:

13              Thermometers

14 Plumbing Specialties:

15              Floor Drains & Cleanouts

16              Hose Bibb

17              Water Hammer Arrestors

18              Backflow Preventers

19 Hangers & Supports

20 Insulation

21 Plbg. Equipment

22

23 Shop drawing submittals are to be bound, labeled, contain the project manual cover page and a material index  
24 list page showing item designation, manufacturer and additional items supplied with the installation. Submit  
25 for all equipment and systems as indicated in the respective specification sections, marking each submittal  
26 with that specification section number. Mark general catalog sheets and drawings to indicate specific items  
27 being submitted and proper identification of equipment by name and/or number, as indicated in the  
28 construction documents. Include wiring diagrams of electrically powered equipment.

29

30 Submit sufficient quantities of equipment data sheets and shop drawings to allow the following distribution:

- 31              • Insertion into Operating and Maintenance Manuals              2 copies
- 32              • Dane County Public Works - record copy                              1 copy
- 33              • Engineers - record copies    2 copies

34

35 **OPERATION AND MAINTENANCE DATA**

36 All operations and maintenance data shall comply with the submission and content requirements specified  
37 under Division 1 - Basic Requirements.

38

39 Two copies of Operations and Maintenance Manuals shall be provided for the following distribution:

- 40              • Dane County Public Works    1 copy
- 41              • Dane County Facilities Management    1 copy

42

43 In addition to the general content specified under - Basic Requirements supply the following additional  
44 documentation:

- 45              1. Records of tests performed a to certify compliance with system requirements
- 46              2. Manufacturer's wiring diagrams for electrically powered equipment
- 47              3. Certificates of inspection by regulatory agencies
- 48              4. Valve schedules
- 49              5. Lubrication instructions, including list/frequency of lubrication
- 50              6. Parts lists for fixtures, equipment, valves and specialties.
- 51              7. Manufacturers installation, operation and maintenance recommendations for fixtures, equipment,  
52              valves and specialties.
- 53              8. Additional information as indicated in the technical specification sections

54

55 **TRAINING OF OWNER PERSONNEL**

1 Instruct owner personnel in the proper operation and maintenance of systems and equipment provided as part  
2 of this project. Include not less than 2 hours of instruction, using the Operating and Maintenance manuals  
3 during this instruction. Demonstrate startup, operation and shutdown procedures for all equipment. All  
4 training to be during normal working hours. Videotape all instructions and provide owner with copy.

5  
6 **RECORD DRAWINGS**

7 Refer to Division 1. - Basic Requirements, As Built and Record Drawings and Specifications.  
8

9 **PART 2 - PRODUCTS**

10  
11 **IDENTIFICATION**

12 **STENCILS:**

13 Not less than 1 inch high letters/numbers for marking pipe and equipment.  
14

15 **ENGRAVED NAME PLATES:**

16 White letters on a black background, 1/16 inch thick plastic laminate, beveled edges, screw mounting,  
17 Setonply Style 2060 by Seton Name Plate Company or Emedolite Style EIP by EMED Co., or equal by W.  
18 H. Brady.  
19

20 **SNAP-AROUND PIPE MARKERS:**

21 One-piece, preformed, vinyl construction, snap-around or strap-around pipe markers with applicable labeling  
22 and flow direction arrows, 3/4" min. size for lettering. Provide nylon ties on each end of pipe markers. Equal  
23 to Seton Setmark.  
24

25 **VALVE TAGS:**

26 Round brass tags with 1/2 inch numbers, 1/4 inch system identification abbreviation, 1-1/4 inch minimum  
27 diameter, with brass jack chains, brass "S" hooks or one piece nylon ties around the valve stem, available  
28 from EMED Co., Seton Name Plate Company, or W. H. Brady.  
29

30 **SEALING AND FIRESTOPPING**

31  
32 **FIRE AND/OR SMOKE RATED PENETRATIONS:**

33  
34 Manufacturers: 3M, Hilti, Rectorseal, STI/SpecSeal, Tremco, or approved equal.  
35

36 All firestopping systems shall be provided by the same manufacturer.  
37

38 Fire stop systems shall be UL listed or tested by an independent testing laboratory approved by the  
39 Department of Commerce.  
40

41 Submittals: Contractor shall submit product data for each firestop system. Submittals shall include product  
42 characteristics, performance and limitation criteria, test data, MSDS sheets, installation details and  
43 procedures for each method of installation applicable to this project. For non-standard conditions where no  
44 UL tested system exists, submit manufacturer's drawings for UL system with known performance for which  
45 an engineering judgement can be based upon.  
46

47 Use a product that has a rating not less than the rating of the wall or floor being penetrated. Reference  
48 architectural drawings for identification of fire and/or smoke rated walls and floors.  
49

50 Use firestop putty, caulk sealant, intumescent wrapstrips, intumescent firestop collars, firestop blocks,  
51 firestop mortar or a combination of these products to provide a UL listed system for each application required  
52 for this project. Provide mineral wool backing where specified in manufacturer's application detail.  
53

54 **NON-RATED PENETRATIONS:**

1  
2 In exterior wall openings below grade, use a modular mechanical type seal consisting of interlocking  
3 synthetic rubber links shaped to continuously fill the annular space between the uninsulated pipe and the  
4 cored opening or a water-stop type wall sleeve. The operating bolts of the mechanical type seal shall be  
5 accessible from the interior of the building.  
6

7 At pipe penetrations of non-rated interior partitions, floors and exterior walls, use urethane caulk in annular  
8 space between pipe insulation and sleeve. For non-rated drywall, plaster or wood partitions where sleeve is  
9 not required use urethane caulk in annular space between pipe insulation and wall material  
10

## 11 **PART 3 - EXECUTION**

### 12 **DEMOLITION**

13  
14 Perform all demolition as indicated on the drawings to accomplish new work. Where demolition work is to  
15 be performed adjacent to existing work that remains in an occupied area, construct temporary dust partition  
16 to minimize the amount of contamination of the occupied space. Where pipe is removed and not reconnected  
17 with new work, cap ends of existing services as if they were new work. Coordinate work with the Owner to  
18 minimize disruption to the existing building occupants.  
19

20  
21 All pipe, fixtures, equipment, wiring and associated conduit, insulation and similar items demolished,  
22 abandoned, or deactivated are to be removed from the site by the Contractor except as specifically noted  
23 otherwise. Maintain the condition of material and/or equipment that is indicated to be reused equal to that  
24 existing before work began.  
25

### 26 **CUTTING AND PATCHING**

27 Provide required Cutting and Patching to complete the work. Refer to Division 1 – Basic Requirements.  
28

### 29 **BUILDING ACCESS**

30 Arrange for the necessary openings in the building to allow for admittance or removal of all apparatus. When  
31 the building access was not previously arranged and must be provided by this contractor, restore any opening  
32 to its original condition after the apparatus has been brought into the building.  
33

34 When access to the work area is through occupied areas coordinate building access times with the Owner's  
35 Project Representative.  
36

### 37 **EQUIPMENT ACCESS**

38 Install all piping, conduit and accessories to permit access to equipment for maintenance and service.  
39

### 40 **COORDINATION**

41 Coordinate all work with other contractors prior to installation. Any work that is not coordinated and that  
42 interferes with other contractor's work shall be removed or relocated at the installing contractor's expense.  
43

44 Verify that all devices are compatible for the type of construction and surfaces on which they will be used.  
45

### 46 **IDENTIFICATION**

47 Identify equipment in mechanical equipment rooms by stenciling equipment number and service with one  
48 coat of black enamel against a light background or white enamel against a dark background. Use a primer  
49 where necessary for proper paint adhesion.  
50

51 Where stenciling is not appropriate for equipment identification, engraved name plates may be used.  
52

53 Identify all new interior piping. Place flow directional arrows at each pipe identification location. Use one  
54 coat of black enamel against a light background or white enamel against a dark background.

1  
2 Identify valves with brass tags bearing a system identification and a valve sequence number. Valve tags are  
3 not required at a terminal device unless the valves are greater than ten feet from the device, located in another  
4 room or not visible from device. Provide a typewritten valve schedule and pipe identification schedule  
5 indicating the valve number and the equipment or areas supplied by each valve and the symbols used for pipe  
6 identification; locate schedules in mechanical room and in each Operating and Maintenance manual.  
7 Schedule in mechanical room to be framed under clear plastic.

8

9 **LUBRICATION**

10 Lubricate all bearings with lubricant as recommended by the manufacturer before the equipment is operated  
11 for any reason. Once the equipment has been run, maintain lubrication in accordance with the manufacturer's  
12 instructions until the work is accepted by the Owner. Maintain a log of all lubricants used and frequency of  
13 lubrication; include this information in the Operating and Maintenance Manuals at the completion of the  
14 project.

15

16 **TRAINING**

17 Contractor to provide factory authorized representative and/or field personnel knowledgeable with the  
18 operations, maintenance and troubleshooting of the system and/or components defined within this section for  
19 a minimum period of 2 hours. Session may be videotaped.

20

21

22

END OF SECTION

23

1  
2  
3  
4  
5  
6  
7  
8  
9  
10  
11  
12  
13  
14  
15  
16  
17  
18  
19  
20  
21  
22  
23  
24  
25  
26  
27  
28  
29  
30  
31  
32  
33  
34  
35  
36  
37  
38  
39  
40  
41  
42  
43  
44  
45  
46  
47  
48  
49  
50  
51  
52  
53  
54  
55  
56  
57  
58  
59  
60  
61

**SECTION 22 05 14**  
**PLUMBING SPECIALTIES**

**PART 1 - GENERAL**

**SCOPE**

This section includes specifications for floor drains, roof drains, cleanouts, backflow preventers, water hammer arrestors and other miscellaneous plumbing specialties.

**PART 1 - GENERAL**

- Scope
- Related Documents
- Reference
- Reference Standards
- Quality Assurance
- Shop Drawings
- Operation and Maintenance Data

**PART 2 - PRODUCTS**

- Floor Drains
- Cleanouts
- Water Hammer Arrestors

**PART 3 - EXECUTION**

- Installation

**RELATED DOCUMENTS**

- Section 22 05 23 – General-Duty Valves for Plumbing Piping
- Section 22 11 00 – Facility Water Distribution
- Section 22 13 06 – Sanitary Waste and Vent
- Section 22 30 00 – Plumbing Equipment

**REFERENCE**

Applicable provisions of Division 1 shall govern work under this section.

**REFERENCE STANDARDS**

- ANSI A112.21.1 - Floor Drains.
- ANSI A112.26.1/PDI WH-201 - Water Hammer Arrestors.
- ASSE 1001 - Pipe Applied Atmospheric Type Vacuum Breakers.
- ASSE 1010 - Water Hammer Arrestors.
- ASSE 1011 - Hose Connection Vacuum Breakers.
- ASSE 1012 - Backflow Preventers with Intermediate Atmospheric Vent.
- ASSE 1013 - Reduced Pressure Principle Backflow Preventers.
- ASSE 1017-86- Thermostatic Mixing Valves
- ASSE 1019 – Wall Hydrants, Frost Proof Automatic Draining, Anti-Backflow Type.

**QUALITY ASSURANCE**

Substitution of Materials: Refer to Section Division 1 – Basic requirements.

Plumbing products requiring approval by the State of Wisconsin Dept. of Safety and Professional Services must be approved or have pending approval at the time of shop drawing submission.

**SHOP DRAWINGS**

Include data concerning dimensions, capacities, materials of construction, ratings, certifications, weights, manufacturer's installation requirements, manufacturer's performance limitations, and appropriate identification.

**PART 2 - PRODUCTS**

**FLOOR DRAINS**

Manufacturer: Sioux Chief, Josam, Smith, Wade, Watts, Zurn.

1  
2 **FD-1:** On-grade, adjustable floor drain with Sch 40 hub connection and cast nickel 6-1/2" round  
3 ring/strainer, equal to Sioux Chief 832-3ANR.

4  
5 **CLEANOUTS**

6 Manufacturer: Sioux Chief, Josam, Smith, Wade, Watts, Zurn.

7  
8 **FCO-1:** Adjustable, on-grade cleanout with Sch. 40 hub connection and cast nickel round ring/strainer,  
9 equal to Sioux Chief 834-P-NR.

10  
11 **INTERIOR FINISHED WALL AREAS:** Line type cleanout tee with tapered threaded ABS cleanout plug,  
12 round polished stainless steel access cover secured with machine screw. Zurn Z-1446- ( Note: Screw  
13 shall not pass completely through the ABS plug, trim screw as necessary )

14  
15 **INTERIOR EXPOSED VERTICAL STACKS:** Line type cleanout tee with tapered threaded ABS closure  
16 plug. Zurn Z-1445.

17  
18 **INTERIOR HORIZONTAL LINES:** Cast iron hub with tapped ferrule and tapered threaded ABS or PVC  
19 closure plug, or no-hub coupling and blind plug.

20  
21 **WATER HAMMER ARRESTORS**

22 Manufacturer: PPP Industries, Sioux Chief, Wade, Watts.

23  
24 ANSI A112.26.1, ASSE 1010; sized in accordance with PDI WH-201, precharged piston type constructed  
25 of hard drawn Type K copper, threaded brass adapter, brass piston with o-ring seals, FDA approved  
26 silicone lubricant, suitable for operation in temperature range 35 to 150 degrees F, maximum 250 psig  
27 working pressure, 1500 psig surge pressure. Watts series 15.

28  
29 **PART 3 - EXECUTION**

30  
31  
32 **INSTALLATION**

33 Coordinate location and setting of plumbing specialties with adjacent construction. Install in accordance  
34 with manufacturers recommendations.

35  
36 Set floor drains and cleanouts level and plumb adjusted to finished floor elevation, roof elevation or  
37 finished wall location. Locate where serviceable. Allow minimum of 18" clearance around cleanouts for  
38 rodding. Lubricate threaded cleanout plugs with graphite and oil, teflon tape or waterproof grease. Install  
39 trap primer connections where indicated. Provide deep seal traps on floor drains and hub drains installed in  
40 mechanical rooms, penthouses or rooms with excessive positive or negative pressure.

41  
42 Install water hammer arrestors where indicated and at quick closing valve installations.

43  
44  
45 **END OF SECTION**  
46  
47

1  
2  
3  
4  
5  
6  
7  
8  
9  
10  
11  
12  
13  
14  
15  
16  
17  
18  
19  
20  
21  
22  
23  
24  
25  
26  
27  
28  
29  
30  
31  
32  
33  
34  
35  
36  
37  
38  
39  
40  
41  
42  
43  
44  
45  
46  
47  
48  
49  
50  
51  
52  
53  
54

**SECTION 22 05 15**  
**PIPING SPECIALTIES**

**PART 1 - GENERAL**

**SCOPE**

This section contains specifications for plumbing piping specialties for all piping systems. Included are the following topics:

**PART 1 - GENERAL**

- Scope
- Related Work
- Reference
- Reference Standards
- Shop Drawings
- Operation and Maintenance Data
- Design Criteria

**PART 2 - PRODUCTS**

- Thermometers
- Thermometer Sockets
- Test Wells
- Test Plugs

**PART 3 - EXECUTION**

- Thermometers
- Thermometer Sockets
- Test Wells
- Test Plugs

**RELATED WORK**

- Section 22 11 00 - Facility Water Distribution Section
- Section 22 05 23 - General-Duty Valves for Plumbing Piping
- Section 22 07 00 - Plumbing Insulation
- Section 22 30 00 - Plumbing Equipment

**REFERENCE**

Applicable provisions of Division 1 govern work under this section.

**REFERENCE STANDARDS**

- ASTM B650 Electrodeposited Engineering Chromium Coatings on Ferrous Substrates

**QUALITY ASSURANCE**

Substitution of Materials: Refer to Division 1 - Basic Requirements.

**SHOP DRAWINGS**

Required for all items in this section. Include materials of construction, dimensional data, ratings/capacities/ranges, approvals, test data, pressure drop data where appropriate, and identification as referenced in this section and/or on the drawings.

**OPERATION AND MAINTENANCE DATA**

All operations and maintenance data shall comply with the submission and content requirements specified under Division 1 - Basic Requirements.

1  
2  
3  
4  
5  
6  
7  
8  
9  
10  
11  
12  
13  
14  
15  
16  
17  
18  
19  
20  
21  
22  
23  
24  
25  
26  
27  
28  
29  
30  
31  
32  
33  
34  
35  
36  
37  
38  
39  
40  
41  
42  
43  
44  
45  
46  
47  
48  
49  
50  
51  
52

**DESIGN CRITERIA**

All piping specialties are to be rated for the highest pressures and temperatures in the respective system in accordance with ANSI B31, but not less than 125 psig unless specifically indicated otherwise.

**PART 2 - PRODUCTS**

**THERMOMETERS**

Ashcroft, Marsh, Taylor, H. O. Trerice, Ametek/U. S. Gauge, Weiss, Wika, Weksler.

Stem Type: Cast aluminum case, nine inch scale, clear acrylic window. adjustable angle brass stem with stem of sufficient length so the end of the stem is near the middle of a pipe without reducing the thickness of any insulation, red indicating fluid, black lettering against a white background, with scale ranges as follows:

<b>Service</b>	Hot Water
<b>Scale Range, °F</b>	30 - 180
<b>Increment, °F</b>	2

**THERMOMETER SOCKETS**

Brass with threaded connections suitable for thermometer stems and temperature control sensing elements in pipeline. Furnish with extension necks for insulated piping systems.

**TEST WELLS**

Similar to thermometer sockets except with a brass cap that threads into the inside of the test well to prevent dirt from accumulating. Secure cap to body with a short chain. Furnish with extension necks, where appropriate, to accommodate the pipeline insulation.

**TEST PLUGS**

Brass threaded pressure and temperature test plug with neoprene self-closing valve, valve retainer, brass threaded cap, rated for 150 psi and 0-200 degrees F.

**PART 3 - EXECUTION**

**THERMOMETERS**

Stem Type: Install in piping systems as indicated on the drawings and/or details using a separable socket in each location.

**THERMOMETER SOCKETS**

Install at each point where a thermometer or temperature control sensing element is located in a pipeline.

**TEST WELLS**

Install in piping systems as indicated on the drawings and/or details wherever provisions are needed for inserting a thermometer at a later date.

**TEST PLUGS**

Install in piping systems as indicated on the drawings and/or details wherever provisions are needed for short-term measurement of pressure or temperature.

END OF SECTION



1  
2  
3  
4  
5  
6  
7  
8  
9  
10  
11  
12  
13  
14  
15  
16  
17  
18  
19  
20  
21  
22  
23  
24  
25  
26  
27  
28  
29  
30  
31  
32  
33  
34  
35  
36  
37  
38  
39  
40  
41  
42  
43  
44  
45  
46  
47  
48  
49  
50  
51  
52  
53  
54

**SECTION 22 05 23**  
**GENERAL DUTY VALVES FOR PLUMBING PIPING**

**PART 1 - GENERAL**

**SCOPE**

This section includes valve specifications for all Plumbing systems except where indicated under Related Work. Included are the following topics:

**PART 1 - GENERAL**

- Scope
- Related Work
- Reference
- Quality Assurance
- Submittals
- Operation and Maintenance Data
- Design Criteria

**PART 2 - PRODUCTS**

- Water System Valves
  - Ball Valves
  - Swing Check Valves
  - Balance Valves
  - Drain Valves

**PART 3 - EXECUTION**

- General
- Shut-off Valves
- Balancing Valves
- Drain Valves

**RELATED WORK**

Section 22 30 00 - Plumbing Equipment

**REFERENCE**

Applicable provisions of Division 1 govern work under this section.

**QUALITY ASSURANCE**

Substitution of Materials: Refer to Division 1 - Basic Requirements.

**SUBMITTALS**

Schedule of all valves indicating type of service, dimensions, materials of construction, and pressure/temperature ratings for all valves to be used on the project. Temperature ratings specified are for continuous operation.

**OPERATION AND MAINTENANCE DATA**

All operations and maintenance data shall comply with the submission and content requirements specified under Division 1 - Basic Requirements.

**DESIGN CRITERIA**

ASSE 1003 - Water Pressure Reducing Valves for Domestic Water Supply Systems.

Where valve types (ball, butterfly, etc.) are specified for individual plumbing services (i.e. domestic water, gas, etc.), each valve type shall be of the same manufacturer unless prior written approval is obtained from the Owner.

Valves to be line size unless specifically noted otherwise.

1  
2  
3  
4  
5  
6  
7  
8  
9  
10  
11  
12  
13  
14  
15  
16  
17  
18  
19  
20  
21  
22  
23  
24  
25  
26  
27  
28  
29  
30  
31  
32  
33  
34  
35  
36  
37  
38  
39  
40  
41  
42  
43  
44  
45  
46  
47  
48  
49  
50  
51  
52  
53

## **PART 2 - PRODUCTS**

### **WATER SYSTEM VALVES**

All water system valves to be rated at not less than 125 water working pressure at 240 degrees F unless noted otherwise.

#### **BALL VALVES:**

2-1/2" and smaller: Two or three piece bronze body; full-port sweat ends, stainless steel ball and stem; glass filled teflon seat; teflon packing and threaded packing nut; blowout-proof stem; 600 psig WOG. Provide valve stem extensions for valves installed in all piping with insulation. Equal to Apollo 77C-140-04 and 77C-240-04. Products by Nibco, Milwaukee, and Watts are considered equal.

#### **SWING CHECK VALVES:**

3" and smaller: Bronze body, sweat ends, Y-pattern, regrindable bronze seat, renewable bronze disc, Class 125, suitable for installation in a horizontal or vertical line with flow upward. Crane 1342, Hammond IB941, Nibco S413B, Watts CVYS, Jomar, Apollo and Milwaukee equals.

#### **BALANCE VALVES:**

Bronze body globe or ball valve with calibrated brass orifice, integral pointer and calibrated scale to register degree of valve opening, memory stop, drain tapping, sweat or threaded ends, with or without integral unions, pressure taps with integral check valves and seals, adjustable memory stop, suitable for 125 psig water working pressure at 240 degrees F. Flowset AccuSetter, Armstrong CBV, Bell & Gossett Circuit Setter Plus, Illinois 6000 series, Tapco Circuit Setter, tour and Anderson.

#### **DRAIN VALVES:**

3/4 inch ball valve with integral threaded hose adapter, sweat or threaded inlet connections, with threaded cap and chain on hose threads, Watts B-6000-CC/B-6001-CC series.

## **PART 3 - EXECUTION**

### **GENERAL**

Properly align piping before installation of valves. Install and test valves in strict accordance with valve manufacturer's installation recommendations. Do not support weight of piping system on valve ends.

Mount valves in locations which allow access for operation, servicing and replacement.

Provide valve handle extensions for all valves installed in insulated piping.

Install all valves with the stem in the upright or horizontal position. If possible, install butterfly valves with the stem in the horizontal position. Valves installed with the stems down will not be accepted.

Prior to flushing of piping systems, place all valves in the full-open position.

### **SHUT-OFF VALVES**

Install shut-off valves at each piece of equipment, at each branch take-off from mains for isolation or repair and elsewhere as indicated.

### **BALANCING VALVES**

Install where indicated on the drawings and details for balancing of flow in pumped hot water recirculation piping systems.

1 Upon project completion, adjust each valve and set position stop. Balance system to minimum flow in  
2 return piping branches needed to maintain even supply water temperature throughout building.

3

4 **DRAIN VALVES**

5 Provide drain valves for complete drainage of all systems. Locations of drain valves include low points of  
6 piping systems, downstream of riser isolation valves, equipment locations specified or detailed, other  
7 locations required for drainage of systems and elsewhere as indicated.

8

9

END OF SECTION

Page Intentionally Left Blank



1  
2 Support apparatus and material under all conditions of operation, variations in installed and operating  
3 weight of equipment and piping, to prevent excess stress, and allow for proper expansion and contraction.

4  
5 Protect insulation at all hanger points; see Related Work above.

6  
7 **SHOP DRAWINGS**

8 Schedule of all hanger and support devices indicating attachment methods and type of device for each pipe  
9 size and type of service.

10  
11 All submittals are to comply with submission and content requirements specified Division 1 - Basic  
12 Requirements.

13  
14 **DESIGN CRITERIA**

15 Materials and application of pipe hangers and supports shall be in accordance with MSS Standard Practice  
16 SP-58 and SP-69 unless noted otherwise.

17  
18  
19 **PART 2 - PRODUCTS**

20  
21 **MANUFACTURERS**

22 Anvil, B-Line, Pate, Piping Technology or approved equal.

23  
24 **STRUCTURAL SUPPORTS**

25 Provide all supporting steel required for the installation of mechanical equipment and materials, including  
26 angles, channels, beams, etc. to suspended or floor supported tanks and equipment. All of this steel may  
27 not be specifically indicated on the drawings.

28  
29 **PIPE HANGERS AND SUPPORTS**

30 **HANGERS FOR PIPE SIZES 1/2" THROUGH 2":**

31 Carbon steel, adjustable swivel ring. B-Line B3170NF, Anvil 69 or 70.

32 Carbon steel, adjustable clevis, standard. B-Line B3100, Anvil 260.

33  
34 **HANGERS FOR PIPE SIZES 2" AND LARGER:**

35 Carbon steel, adjustable clevis, standard. B-Line B3100, Anvil 260.

36  
37 **MULTIPLE OR TRAPEZE HANGERS:**

38 Steel channels with welded spacers and hanger rods.

39  
40 **WALL SUPPORT:**

41 Carbon steel welded bracket with hanger. B-Line 3068 Series, Anvil 194 Series.

42  
43 Perforated, epoxy painted finish, 16-12 gauge, min., steel channels securely anchored to wall structure,  
44 with interlocking, split-type, bolt secured, galvanized pipe/tubing clamps. B-Line type S channel with B-  
45 2000 series clamps, Anvil type PS 200 H with PS 1200 clamps. When copper piping is being supported,  
46 provide flexible elastomeric/thermoplastic isolation cushion material to completely encircle the piping and  
47 avoid contact with the channel or clamp, equal to B-Line B1999 Vibra Cushion or provide manufacturers  
48 clamp and cushion assemblies, B-Line BVT series, and Anvil PS 1400 series.

49  
50 **VERTICAL SUPPORT:**

51 Carbon steel riser clamp. B-Line B3373, Anvil 261 for above floor use.

52  
53 **FLOOR SUPPORT:**

54 Carbon steel pipe saddle, stand and bolted floor flange. B-Line B3088T/B3093.

1  
2 **COPPER PIPE SUPPORTS:**  
3 All supports, fasteners, clamps, etc. directly connected to copper piping shall be copper plated or  
4 polyvinylchloride coated. Where steel channels are used, provide isolation collar between  
5 supports/clamps/fasteners and copper piping.  
6

7 **PIPE HANGER RODS**

8 **STEEL HANGER RODS:**  
9 Threaded both ends, threaded one end, or continuous threaded, complete with adjusting and lock nuts.

10  
11 Size rods for individual hangers and trapeze support as indicated in the following schedule.

12  
13 Total weight of equipment, including valves, fittings, pipe, pipe content, and insulation, are not to exceed  
14 the limits indicated.

15	Maximum Load (Lbs.)	Rod Diameter
16	<u>(650°F Maximum Temp.)</u>	<u>(inches)</u>
17	610	3/8
18	1130	1/2
19	1810	5/8
20	2710	3/4
21	3770	7/8
22	4960	1
23	8000	1-1/4

24  
25 **BEAM CLAMPS**

26 MSS SP-69 Types 19 & 23 malleable black iron clamp for attachment to beam flange to 0.62 inches thick  
27 with a retaining ring and threaded rod of 3/8, 1/2, and 5/8 inch diameter. Furnish with a hardened steel cup  
28 point set screw. B-Line B3036L/B3034, Anvil 86/92.

29  
30 MSS SP-69 Type 28 or Type 29 forged steel jaw type clamp with a tie rod to lock clamp in place, suitable  
31 for rod sizes to 1-1/2 inch diameter. B-Line B3054, Anvil 228.

32  
33 **CONCRETE INSERTS**

34 **POURED IN PLACE:**

35 MSS SP-69 Type 18 wedge type to be constructed of a black carbon steel body with a removable malleable  
36 iron nut that accepts threaded rod to 7/8 inch diameter. Wedge design to allow the insert to be held by  
37 concrete in compression to maximize the load carrying capacity. B-Line B2505, Anvil 281.

38  
39 MSS SP-69 Type 18 universal type to be constructed of black malleable iron body with a removable  
40 malleable iron nut that accepts threaded rod to 7/8 inch diameter. B-Line B3014N, Anvil 282.

41  
42 **DRILLED FASTENERS:**

43 Carbon steel expansion anchors, vibration resistant, with ASTM B633 zinc plating. Use drill bit of same  
44 manufacturer as anchor. Hilti, Rawl, Redhead.

45  
46 **ANCHORS**

47 Use welding steel shapes, plates, and bars to secure piping to the structure.  
48  
49

50 **PART 3 - EXECUTION**

51  
52 **INSTALLATION**

53 Size, apply and install supports and anchors in compliance with manufacturers recommendations.  
54

1 Install supports to provide for free expansion of the piping system. Support all piping from the structure  
2 using concrete inserts, beam clamps, ceiling plates, wall brackets, or floor stands. Fasten ceiling plates and  
3 wall brackets securely to the structure and test to demonstrate the adequacy of the fastening.

4  
5 Coordinate hanger and support installation to properly group piping of all trades.

6  
7 Where piping can be conveniently grouped to allow the use of trapeze type supports, use standard structural  
8 shapes or continuous insert channels for the supporting steel. Where continuous insert channels are used,  
9 pipe supporting devices made specifically for use with the channels may be substituted for the specified  
10 supporting devices provided that similar types are used and all data is submitted for prior approval.

11  
12 Size and install hangers and supports, except for riser clamps, for installation on the exterior of piping  
13 insulation. Where a vapor barrier is not required, hangers may be installed either on the exterior of pipe  
14 insulation or directly on piping.

15  
16 Perform welding in accordance with standards of the American Welding Society.

### 17 18 **HANGER AND SUPPORT SPACING**

19 Install hangers to provide minimum 1/2 inch space between finished covering and adjacent work.

20  
21 Place a hanger within 12 inches of each horizontal elbow, valve, strainer, or similar piping specialty item.

22  
23 Use hangers with 1-1/2 inch minimum vertical adjustment.

24  
25 Where several pipes can be installed in parallel and at the same elevation, provide multiple or trapeze  
26 hangers.

27  
28 Support riser piping independently of connected horizontal piping.

29  
30 Adjust hangers to obtain the slope specified in the piping section of these specifications.

31  
32 Space hangers for pipe as follows:

<u>Pipe Material</u>	<u>Pipe Size</u>	<u>Max. Horiz. Spacing</u>	<u>Max. Vert. Spacing</u>
Copper	1/2" through 3/4"	5'-0"	10'-0"
Copper	1" through 1-1/4"	6'-0"	10'-0"
Copper	1-1/2" through 2-1/2"	8'-0"	10'-0"
Steel	1/2" through 1-1/4"	7'-0"	15'-0"
Steel	1-1/2" through 6"	10'-0"	15'-0"
Plastic	Drain & Vent	5'-0"	15'-0"

### 40 41 **RISER CLAMPS**

42 Support vertical piping with clamps secured to the piping and resting on the building structure or secured to  
43 the building structure below at each floor.

### 44 45 **CONCRETE INSERTS**

46 Select size based on the manufacturer's stated load capacity and weight of material that will be supported.  
47 Use inserts for suspending hangers from reinforced concrete slabs and sides of reinforced concrete beams.  
48 Provide hooked rod to concrete reinforcement section for inserts carrying pipe over 4 inch size. Where  
49 concrete slabs form finished ceiling, provide inserts that are flush with the slab surface.

### 50 51 **ANCHORS**

52 Install where indicated on the drawings and details. Where not specifically indicated, install anchors at  
53 ends of principal pipe runs and at intermediate points in pipe runs between expansion loops. Make  
54 provisions for preset of anchors as required to accommodate both expansion and contraction of piping.



1  
2  
3

END OF SECTION

Page Intentionally Left Blank

1  
2  
3  
4  
5  
6  
7  
8  
9  
10  
11  
12  
13  
14  
15  
16  
17  
18  
19  
20  
21  
22  
23  
24  
25  
26  
27  
28  
29  
30  
31  
32  
33  
34  
35  
36  
37  
38  
39  
40  
41  
42  
43  
44  
45  
46  
47  
48  
49  
50  
51  
52  
53  
54

**SECTION 22 07 00**  
**PLUMBING INSULATION**

**PART 1 - GENERAL**

**SCOPE**

This section includes insulation specifications for plumbing piping and equipment. Included are the following topics:

**PART 1 - GENERAL**

- Scope
- Related Work
- Reference
- Reference Standards
- Quality Assurance
- Description
- Definitions
- Shop Drawings
- Operation and Maintenance Data

**PART 2 - PRODUCTS**

- Materials
- Insulation & Jackets
- Insulation Inserts and Pipe Shields
- Accessories

**PART 3 - EXECUTION**

- Installation
- Piping, Valve and Fitting Insulation
- Construction Verification Items

**RELATED WORK**

- Section 22 05 00 - Common Work Results for Plumbing
- Section 22 11 00 - Facility Water Distribution
- Section 22 30 00 - Plumbing Equipment

**REFERENCE**

Applicable provisions of Division 1 govern work under this section.

**REFERENCE STANDARDS**

ASTM B209	Aluminum and Aluminum Alloy Sheet and Plate
ASTM C165	Test Method for Compressive Properties of Thermal Insulations
ASTM C177	Heat Flux and Thermal Transmission Properties
ASTM C195	Mineral Fiber Thermal Insulation Cement
ASTM C302	Density of Preformed Pipe Insulation
ASTM C449	Mineral Fiber Hydraulic Setting Thermal Insulation Cement
ASTM C518	Heat Flux and Thermal Transmission Properties
ASTM C547	Mineral Fiber Preformed Pipe Insulation
ASTM C553	Mineral Fiber Blanket and Felt Insulation
ASTM C612	Mineral Fiber Block and Board Thermal Insulation
ASTM C921	Properties of Jacketing Materials for Thermal Insulation
ASTM C1136	Flexible Low Permeance Vapor Retarders for Thermal Insulation
ASTM E84	Surface Burning Characteristics of Building Materials
MICA	National Commercial & Industrial Insulation Standards
NFPA 225	Surface Burning Characteristics of Building Materials
UL 723	Surface Burning Characteristics of Building Materials

1 **QUALITY ASSURANCE**

2 Substitution of Materials: Refer to Division 1 - Basic Requirements.

3

4 Label all insulating products delivered to the construction site with the manufacturer's name and description  
5 of materials.

6

7 **DESCRIPTION**

8 Furnish and install all insulating materials and accessories as specified or as required for a complete  
9 installation. The following types of insulation are specified in this section:

- 10 • Pipe Insulation

11

12 Install all insulation in accordance with the latest edition of MICA (Midwest Insulation Contractors  
13 Association) Standard and manufacturer's installation instructions. Exceptions to these standards will only  
14 be accepted where specifically modified in these specifications, or where prior written approval has been  
15 obtained from the Project Representative.

16

17 **DEFINITIONS**

18 Concealed: shafts, furred spaces, space above finished ceilings, utility tunnels and crawl spaces. All other  
19 areas, including walk-through tunnels, shall be considered as exposed.

20

21 **SHOP DRAWINGS**

22 Submit a schedule of all insulating materials to be used on the project, including adhesives, fastening  
23 methods, fitting materials along with material safety data sheets and intended use of each material. Include  
24 manufacturer's technical data sheets indicating density, thermal characteristics, jacket type, and  
25 manufacturer's installation instructions.

26

27 **OPERATION AND MAINTENANCE DATA**

28 All operations and maintenance data shall comply with the submission and content requirements specified  
29 under Division 1 - Basic Requirements.

30

31

32 **PART 2 - PRODUCTS**

33

34 **MATERIALS**

35 Materials or accessories containing asbestos will not be accepted.

36

37 Use composite insulation systems (insulation, jackets, sealants, mastics, and adhesives) that have a flame  
38 spread rating of 25 or less and smoke developed rating of 50 or less, with the following exceptions:

39

40 Insulation which is not located in an air plenum may have a flame spread rating not over 25 and a  
41 smoke developed rating no higher than 150.

42

43 **INSULATION AND JACKETS**

44 Manufacturers: Armstrong, Certainteed Manson, Childers, Dow, Extol, Halstead, H.B. Fuller, Imcoa,  
45 Knauf, Owens-Corning, Pittsburgh Corning, Rubatex, Johns-Mansville, or approved equal.

46

47 Insulating materials shall be fire retardant, moisture and mildew resistant, and vermin proof. Insulation  
48 shall be suitable to receive jackets, adhesives and coatings as indicated.

49

50 **RIGID FIBERGLASS INSULATION:**

51 Minimum nominal density of 3 lbs. per cu. ft., and thermal conductivity of not more than 0.23 at 75 degrees  
52 F, minimum compressive strength of 25 PSF at 10% deformation, rated for service to 450 degrees F.

53

1 White kraft reinforced foil vapor barrier all service jacket, factory applied to insulation with a self-sealing  
2 pressure sensitive adhesive lap, maximum permeance of .02 perms and minimum beach puncture resistance  
3 of 50 units.  
4

5 **SEMI-RIGID FIBERGLASS INSULATION:**

6 Minimum nominal density of 3 lbs. per cu. ft., thermal conductivity of not more than 0.28 at 75 degrees F,  
7 minimum compressive strength of 125 PSF at 10% deformation, rated for service to 450 degrees F.  
8 Insulation fibers perpendicular to jacket and scored for wrapping cylindrical surfaces.  
9

10 White kraft reinforced foil vapor barrier all service jacket, factory applied to insulation with a maximum  
11 permeance of .02 perms and minimum beach puncture resistance of 50 units.  
12

13 **FIREPROOFING INSULATION:**

14 Mineral fiber with nominal density of 8 lbs. per cu. ft., flame spread index of 15, fuel contribution index of  
15 0, and smoke developed index of 0, thermal conductivity of not more than 0.23 at 75 degrees F.  
16

17 Jacket material shall be the same as jacket for adjacent insulation.  
18

19 **METAL JACKETS:**

20 .016 inch thick aluminum or .010 inch thick stainless steel with safety edge.  
21

22 **INSULATION INSERTS AND PIPE SHIELDS**

23 Manufacturers: B-Line, Pipe Shields, Value Engineered Products  
24

25 Construct inserts with calcium silicate, minimum 140 psi compressive strength. Piping 12" and larger,  
26 supplement with high density 600 psi structural calcium silicate insert. Provide galvanized steel shield.  
27 Insert and shield to be minimum 180 degree coverage on bottom of supported piping and full 360 degree  
28 coverage on clamped piping. On roller mounted piping and piping designed to slide on support, provide  
29 additional load distribution steel plate.  
30

31 Where contractor proposes shop/site fabricated inserts and shields, submit schedule of materials,  
32 thicknesses, gauges and lengths for each pipe size to demonstrate equivalency to pre-engineered pre-  
33 manufactured product described above. On low temperature systems, extruded polystyrene may be  
34 substituted for calcium silicate provided insert and shield length and gauge are increased to compensate for  
35 lower insulation compressive strength.  
36

37 Precompressed 20# density molded fiberglass blocks, Hamfab or equal, of same thickness as adjacent  
38 insulation may be substituted for calcium silicate inserts with one 1"x 6" block for piping through 2-1/2"  
39 and three 1" x 6" blocks for piping through 4". Submit shield schedule to demonstrate equivalency to pre-  
40 engineered/pre-manufactured product described above.  
41

42 Wood blocks will not be accepted.  
43

44 **ACCESSORIES**

45 All products shall be compatible with surfaces and materials on which they are applied, and be suitable for  
46 use at operating temperatures of the systems to which they are applied.  
47

48 Adhesives, sealants, and protective finishes shall be as recommended by insulation manufacturer for  
49 applications specified.  
50

51 Insulation bands to be 3/4 inch wide, constructed of aluminum or stainless steel. Minimum thickness to be  
52 .015 inch for aluminum and .010 inch for stainless steel.  
53

54 Tack fasteners to be stainless steel ring grooved shank tacks.

- 1
- 2 Staples to be clinch style.
- 3
- 4 Insulating cement to be ANSI/ASTM C195, hydraulic setting mineral wool.
- 5
- 6 Finishing cement to be ASTM C449.
- 7
- 8 Fibrous glass or canvas fabric reinforcing shall have a minimum untreated weight of 6 oz./sq. yd.
- 9
- 10 Bedding compounds to be non-shrinking and permanently flexible.
- 11
- 12 Vapor barrier coatings to be non-flammable, fire resistant, polymeric resin.
- 13
- 14 Fungicidal water base coating (Foster 40-20 or equal) to be compatible with vapor barrier coating.
- 15
- 16

17 **PART 3 - EXECUTION**

18

19 **INSTALLATION**

20 Install insulation, jackets and accessories in accordance with manufacturers instructions and under ambient  
21 temperatures and conditions recommended by manufacturer. Surfaces to be insulated must be clean and  
22 dry.

23

24 Do not insulate systems or equipment which are specified to be pressure tested or inspected, until testing,  
25 inspection and any necessary repairs have been successfully completed.

26

27 Install insulation with smooth and even surfaces. Poorly fitted joints or use of filler in voids will not be  
28 accepted. Cover and seal exposed fiberglass insulation when insulation is terminated, no raw fiberglass  
29 insulation is allowed. Provide neat and coated terminations at all nameplates, uninsulated fittings, or at  
30 other locations where insulation terminates. Install with longitudinal joints facing wall or ceiling.

31

32 Install fabric reinforcing without wrinkles. Overlap seams a minimum of 2 inches.

33

34 Use full-length material (as delivered from manufacturer) wherever possible. Scrap piecing of insulation or  
35 pieces cut undersize and stretched to fit will not be accepted.

36

37 Insulation shall be continuous through sleeves and openings. Vapor barriers shall be maintained continuous  
38 through all penetrations.

39

40 Provide a complete vapor barrier for insulation on the following systems:

- 41 • Cold water

42

43 **PIPING, VALVE, AND FITTING INSULATION**

44 **GENERAL:**

45 Install insulation with butt joints and longitudinal seams closed tightly. Provide minimum 2” lap on jacket  
46 seams and 2” tape on butt joints, firmly cemented with lap adhesive. Additionally secure with staples along  
47 seams and butt joints. Coat staples with vapor barrier mastic on systems requiring vapor barrier.

48

49 Water supply piping insulation shall be continuous throughout the building and installed adjacent to and  
50 within building walls to a point directly behind the fixture that is being supplied.

51

52 Install insulation continuous through pipe hangers and supports with hangers and supports on the exterior  
53 of insulation. Where a vapor barrier is not required, hangers and supports may be attached directly to piping  
54 with insulation completely covering hanger or support and jacket sealed at support rod penetration. Where

1 riser clamps are required to be attached directly to piping requiring vapor barrier, extend insulation and  
2 vapor barrier jacketing/coating around riser clamp.

3

4 **INSULATION INSERTS AND PIPE SHIELDS:**

5 Provide insulation inserts and pipe shields at all hanger and support locations. Inserts may be omitted on  
6 3/4" and smaller copper piping provided 12" long 22 gauge pipe shields are used.

7

8 **FITTINGS AND VALVES:**

9 Fittings, valves, unions, flanges, couplings and specialties may be insulated with factory molded or built up  
10 insulation of the same thickness as adjoining insulation. Cover insulation with fabric reinforcing and mastic  
11 or where temperatures do not exceed 150 degrees, PVC fitting covers. Secure PVC fitting covers with tack  
12 fasteners and 1-1/2" band of mastic over ends, throat, seams or penetrations. On systems requiring vapor  
13 barrier, use vapor barrier mastic.

14

15 **PIPE INSULATION SCHEDULE:**

16 Provide insulation on new and existing remodeled piping as indicated in the following schedule:

17

18

19 <b>Service</b>	20 <b>Insulation</b>	21 <b>Insulation Thickness by Pipe Size</b>				
		22 <b>1" and</b>	23 <b>1-1/4"</b>	24 <b>2-1/2"</b>	25 <b>5" to 6"</b>	26 <b>8" and</b>
		27 <b>smaller</b>	28 <b>to 2"</b>	29 <b>to 4"</b>		30 <b>larger</b>
Hot Water Supply & Tempered Water	Rigid Fiberglass	1.5"	1.5"	1.5"	1.5"	1.5"
Hot Water Circulating	Rigid Fiberglass	1"	1"	1.5"		
Cold Water	Rigid Fiberglass	0.5"	0.5"	1"	1"	1"

28

29

30

END OF SECTION

Page Intentionally Left Blank





1	ASTM A234	Pipe Fittings of Wrought Carbon Steel and Alloy Steel for Moderate and Elevated
2		Temperatures
3	ASTM B32	Solder Metal
4	ASTM B88	Seamless Copper Water Tube
5	ASTM B280	Seamless Copper Tube for Air Conditioning and Refrigeration Field Service
6	ASTM B813	Liquid and Paste Fluxes for Soldering Applications of Copper and Copper Alloy Tube
7	AWS A5.8	Brazing Filler Metal
8	AWWA C104	Cement Mortar Lining for Ductile Iron Pipe and Fittings for Water
9	AWWA C105	Polyethylene Encasement for Ductile Iron Piping for Water
10	AWWA C110	Ductile Iron and Gray Iron Fittings, 3 In. Through 48 In., for Water and Other Liquids
11	AWWA C111	Rubber Gasket Joints for Ductile Iron and Gray Iron Pressure Pipe and Fittings
12	AWWA C151	Ductile Iron Pipe, Centrifugally Cast in Metal Molds or Sand-Lined Molds for Water or
13		Other Liquids
14	AWWA C153	Ductile Iron Compact Fittings, 3 In. Through 48 In., for Water and Other Liquids
15	AWWA C600	Installation of Ductile Iron Water Mains and Their Appurtenances
16	AWWA C651	Disinfecting Water Mains

17

18 **SHOP DRAWINGS**

19 Schedule from the contractor indicating the ASTM, AWWA or CISPI specification number of the pipe  
 20 being proposed along with its type and grade if known at the time of submittal, and sufficient information  
 21 to indicate the type and rating of fittings for each service.

22

23 Statement from manufacturer on his letterhead that pipe furnished meets the ASTM, AWWA or CISPI  
 24 specification contained in this section.

25

26 **QUALITY ASSURANCE**

27 Substitution of Materials: Refer to Division 1 - Basic Requirements.

28

29 Order all copper, cast iron and steel with each length marked with the name or trademark of the  
 30 manufacturer and type of pipe; with each shipping unit marked with the purchase order number, metal or  
 31 alloy designation, temper, size, and name of supplier.

32

33 Any installed material not meeting the specification requirements must be replaced with material that meets  
 34 these specifications without additional cost to the Owner.

35

36 **DELIVERY, STORAGE, AND HANDLING**

37 Promptly inspect shipments to insure that the material is undamaged and complies with specifications.

38

39 Cover pipe to prevent corrosion or deterioration while allowing sufficient ventilation to avoid  
 40 condensation. Do not store materials directly on grade. Protect pipe, tube, and fitting ends so they are not  
 41 damaged. Where end caps are provided or specified, take precautions so the caps remain in place. Protect  
 42 fittings, flanges, and unions by storage inside or by durable, waterproof, above ground packaging.

43

44 Storage and protection methods must allow inspection to verify products.

45

46 **DESIGN CRITERIA**

47 Use only new material, free of defects, rust and scale, and meeting the latest revision of ASTM, AWWA or  
 48 CISPI specifications as listed in this specification.

49

50 Construct all piping for the highest pressures and temperatures in the respective system.

51

52 Non-metallic piping will be acceptable only for the services indicated. It will not be acceptable in  
 53 ventilation plenum spaces, including plenum ceilings.

54

1 Where weld fittings or mechanical grooved fittings are used, use only long radius elbows having a  
2 centerline radius of 1.5 pipe diameters.

3  
4 Where ASTM A53 type F pipe is specified, grade A type E or S, or grade B type E or S may be substituted  
5 at Contractor's option. Where the grade or type is not specified, Contractor may choose from those  
6 commercially available.

7  
8 Where ASTM B88, type L H (drawn) temper copper tubing is specified, ASTM B88, type K H (drawn)  
9 temper copper tubing may be substituted at Contractor's option.

## 10 11 12 **PART 2 - PRODUCTS**

### 13 14 **DOMESTIC WATER**

#### 15 **ABOVE GROUND:**

16 Type L copper water tube, H (drawn) temper, ASTM B88; wrought copper pressure fittings, ANSI B16.22;  
17 lead free (<.2%) solder, ASTM B32; flux, ASTM B813; copper phosphorous brazing alloy, AWS A5.8  
18 BCuP. Copper mechanical grooved fittings and couplings on roll grooved pipe may be used in lieu of  
19 soldered fittings. Mechanically formed brazed tee connections may be used in lieu of specified tee fittings  
20 for branch takeoffs up to one-half (1/2) the diameter of the main.

21  
22 Chlorinated Poly Vinyl Chloride (PVC) pipe and fittings, ASTM D2846.

23  
24 Galvanized steel, Schedule 40, Grade A, ASTM A53; with cast iron threaded fittings, Class 125, ANSI  
25 B16.4; forged steel threaded fittings, ANSI 16.11; mechanical cut groove couplings and fittings; galvanize  
26 coat all fittings, ASTM A123.

27  
28 Fittings 4" and larger may be cast iron, flanged, galvanized, 125 psi, ANSI standard B16.1 with neoprene  
29 gasket.

#### 30 31 **DIELECTRIC UNIONS AND FLANGES**

32 Watts Regulator Company, Lochinvar, Wilkins or EPCO Sales, Inc., dielectric unions 2" and smaller;  
33 dielectric flanges 2" and larger; with iron female pipe thread to copper solder joint or brass female pipe  
34 thread end connections, non-asbestos gaskets, having a pressure rating of not less than 175 psig at 180  
35 degrees.

#### 36 37 **UNIONS AND FLANGES**

38 Unions, flanges and gasket materials to have a pressure rating of not less than 150 psig at 180 degrees.  
39 Gasket material for flanges and flanged fittings shall be teflon type. Treated paper gaskets are not  
40 acceptable.

#### 41 42 **2" AND SMALLER STEEL:**

43 ASTM A197/ANSI B16.3 malleable iron unions with brass seats. Use black malleable iron on black steel  
44 piping and galvanized malleable iron on galvanized steel piping.

#### 45 46 **2" AND SMALLER COPPER:**

47 ANSI B16.18 cast bronze union coupling or ANSI B15.24 Class 150 cast bronze flanges.

#### 48 49 **2-1/2" AND LARGER STEEL:**

50 ASTM A181 or A105, grade 1 hot forged steel flanges of threaded, welding neck, or slip-on pattern on  
51 black steel and threaded only on galvanized steel. Use raised face flanges ANSI B16.5 for mating with  
52 other raised face flanges or equipment with flat ring or full face gaskets. Use ANSI B16.1 flat face flanges  
53 with full face teflon gaskets for mating with other flat face flanges on equipment. Gaskets shall be teflon  
54 type.

1  
2 2-1/2" AND LARGER COPPER:  
3 ANSI B15.24 Class 150 cast bronze flanges with full face teflon gaskets.

### 4 5 **PART 3 - EXECUTION**

#### 6 7 **GENERAL**

8 Install pipe and fittings in accordance with reference standards, manufacturers recommendations and  
9 recognized industry practices.

#### 10 11 **PREPARATION**

12 Cut pipe ends square. Ream ends of piping to remove burrs. Clean scale and dirt from interior and exterior  
13 of each section of pipe and fitting prior to assembly.

14  
15 Piping shall be pitched to drain entire system; install drain vales at low points. Provide unions at piping  
16 connections to all equipment, control valves etc. Provide offsets and transition fittings are required.

17  
18 No water piping shall be installed in exterior walls above grade unless specifically approved by A/E and  
19 unless adequately protected from freezing. Two inch insulation shall be installed on back and sides of  
20 chase, front shall be open to rom heat, covered only by finished wall material.

21  
22 Where copper or steel piping is embedded in masonry or concrete, provide protective sleeve covering of  
23 elastomeric pipe insulation.

24  
25 Use dielectric unions for connecting copper and steel piping.

#### 26 27 **ERECTION**

28 Install all piping parallel to building walls and ceilings and at heights which do not obstruct any portion of a  
29 window, doorway, stairway, or passageway. Where interferences develop in the field, offset or reroute  
30 piping as required to clear such interferences. Coordinate locations of plumbing piping with piping,  
31 ductwork, conduit and equipment of other trades to allow sufficient clearances. In all cases, consult  
32 drawings for exact location of pipe spaces, ceiling heights, door and window openings, or other  
33 architectural details before installing piping.

34  
35 Maintain piping in clean condition internally during construction.

36  
37 Provide clearance for installation of insulation, access to valves and piping specialties.

38  
39 Provide anchors, expansion joints, swing joints and/or expansion loops so that piping may expand and  
40 contract without damage to itself, equipment, or building.

41  
42 Do not route piping through transformer vaults or above transformers, elevator equipment rooms,  
43 panelboards, or switchboards, including the required service space for this equipment, unless the piping is  
44 serving this equipment

45  
46 Install all valves and piping specialties, including items furnished by others, as specified and/or detailed.  
47 Provide access to valves and specialties for maintenance. Make connections to all equipment, fixtures and  
48 systems installed by others where same requires the piping services indicated in this section.

49  
50 Use dielectric unions for connecting copper and steel piping.

51  
52 Provide necessary backflow devices as required by code.

53  
54 Extend hot water piping from water heaters and connect to all fixtures and equipment as required.

1  
2 Hot water, hot water return and cold water lines shall be kept at least six (6) inches apart whenever  
3 possible.

#### 4 5 **HOT WATER CIRCULATING SYSTEM**

6 Install return system including check valves, balancing valves, and circulating pump.

7  
8 Pitch and grade all lines as required to ensure satisfactory circulation. Avoid dips or depressions in pipe  
9 runs.

10  
11 Install time clock, and adjust times per owners direction.

12  
13 Balance return flow to provide continuous circulation throughout entire system. Test and demonstrate this  
14 to the A/E.

#### 15 16 **COPPER PIPE JOINTS**

17 Remove all slivers and burrs remaining from the cutting operation by reaming and filing both pipe surfaces.  
18 Clean fitting and tube with metal brush, emery cloth or sandpaper. Remove residue from the cleaning  
19 operation, apply flux and assemble joint to socket stop. Apply flame to fitting until solder melts when  
20 placed at joint. Remove flame and feed solder into joint until full penetration of cup and ring of solder  
21 appears. Wipe excess solder and flux from joint.

#### 22 23 **THREADED PIPE JOINTS**

24 Use a thread lubricant or teflon tape when making joints; no hard setting pipe thread cement or caulking  
25 will be allowed.

#### 26 27 **WATER HAMMER ARRESTORS**

28 Water supply piping serving fixtures, appliance, and equipment with quick closing devices shall be  
29 provided with water hammer suppressors.

30  
31 Shock absorbing devices shall be mechanical suppressors as required and approved by the Plumbing code.  
32 Mechanical suppressors shall be installed in accordance with hydraulic design of system and PDI Std.  
33 WH201.

#### 34 35 **STERILIZATION OF WATER DISTRIBUTION SYSTEM**

36 Prior to use, isolate and fill system with potable water. Allow to stand 24 hours. Flush each outlet  
37 proceeding from the service entrance to the furthest outlet for minimum of 1 minute and until water appears  
38 clear. Fill system with a solution of water and chlorine containing at least 50 parts per million of chlorine  
39 and allow to stand for 24 hours. Alternately a solution containing at least 200 parts per million of chlorine  
40 may be used and allowed to stand for 3 hours. Flush system with potable water until chlorine concentration  
41 is no higher than source water level.

42  
43 Wait 24 hours after final flushing. Take samples of water for lab testing. The number and location of  
44 samples shall be representative of the system size and configuration and are subject to approval by  
45 Engineer. Test shall show the absence of coliform bacteria. If test fails, repeat disinfection and testing  
46 procedures until no coliform bacteria are detected. Submit test report indicating date and time of test along  
47 with test results.

#### 48 49 **DIELECTRIC UNIONS AND FLANGES**

50 Install dielectric unions or flanges at each point where a copper-to-steel pipe connection is required in  
51 domestic water systems.

#### 52 53 **UNIONS AND FLANGES**

1 Install a union or flange at each connection to each piece of equipment and at other items which may  
2 require removal for maintenance, repair, or replacement. Where a valve is located at a piece of equipment,  
3 locate the flange or union connection on the equipment side of the valve. Concealed unions or flanges are  
4 not acceptable.

5

6 **PIPING SYSTEM LEAK TESTS**

7 Isolate or remove components from system which are not rated for test pressure. Test piping in sections or  
8 entire system as required by sequence of construction. Do not insulate or conceal pipe until it has been  
9 successfully tested.

10

11 If required for the additional pressure load under test, provide temporary restraints at fittings or expansion  
12 joints. Backfill underground water mains prior to testing with the exception of thrust restrained valves  
13 which may be exposed to isolate potential leaks.

14

15 For hydrostatic tests, use clean water and remove all air from the piping being tested by means of air vents  
16 or loosening of flanges/unions. Measure and record test pressure at the high point in the system.

17

18 Inspect system for leaks. Where leaks occur, repair the area with new materials and repeat the test; caulking  
19 will not be acceptable.

20

21 Entire test must be witnessed by the Owners Project Representative. All pressure tests are to be  
22 documented on forms to be provided to the contractor.

23

	Test	<u>Initial Test</u>		<u>Final Test</u>	
<u>System</u>	<u>Medium</u>	<u>Pressure</u>	<u>Duration</u>	<u>Pressure</u>	<u>Duration</u>
Above Ground Domestic Water	Water	N/A		100 psig	8 hr

26

27

28

29

**END OF SECTION**

1 **PIPING SYSTEM TEST REPORT**

2  
3 **Date Submitted:** \_\_\_\_\_

4  
5 **Project Name:** \_\_\_\_\_

6  
7 **Location:** \_\_\_\_\_ **Project No:** \_\_\_\_\_

8  
9 **Contractor:** \_\_\_\_\_

10  
11  Plumbing  Fire Sprinkler

12 Test Medium:  Air  Water  Other \_\_\_\_\_

13  
14 Test performed per specification section No. \_\_\_\_\_

15  
16 Specified Test Duration \_\_\_\_\_ Hours Specified Test Pressure \_\_\_\_\_ PSIG

17  
18 System Identification: \_\_\_\_\_

19 Describe Location: \_\_\_\_\_

20 \_\_\_\_\_

21	Test Date: _____	
22		
23	Start Test Time: _____	Initial Pressure: _____ PSIG
24		
25	Stop Test Time: _____	Final Pressure: _____ PSIG
26		

27 Tested By: \_\_\_\_\_ Witnessed By: \_\_\_\_\_

28 Title: \_\_\_\_\_ Title: \_\_\_\_\_

29 Signed: \_\_\_\_\_ Signed: \_\_\_\_\_

30 Date: \_\_\_\_\_ Date: \_\_\_\_\_

31 Comments: \_\_\_\_\_

32 \_\_\_\_\_

33 \_\_\_\_\_

34 \_\_\_\_\_

35 \_\_\_\_\_

36 \_\_\_\_\_

37 \_\_\_\_\_

Page Intentionally Left Blank



1  
2  
3  
4  
5  
6  
7  
8  
9  
10  
11  
12  
13  
14  
15  
16  
17  
18  
19  
20  
21  
22  
23  
24  
25  
26  
27  
28  
29  
30  
31  
32  
33  
34  
35  
36  
37  
38  
39  
40  
41  
42  
43  
44  
45  
46  
47  
48  
49  
50  
51  
52  
53  
54  
55  
56

**SECTION 22 13 00**  
**SANITARY WASTE AND VENT PIPING**

**PART 1 – GENERAL**

**SCOPE**

This section contains specifications for plumbing pipe and pipe fittings for this project.

**RELATED WORK**

22 05 29 – Hangers and Supports for Plumbing Piping and Equipment

22 05 15 – Piping Specialties

**REFERENCE**

Applicable provisions of Division 1 govern work under this section.

**REFERENCE STANDARDS**

ANSI A21.4

ANSI A21.11

ANSI A21.51

ANSI B16.3

Malleable Iron Threaded Fittings

ANSI B16.4

Cast Iron Threaded Fittings

ANSI B16.5

Pipe Flanges and Flanged Fittings

ANSI B16.22

Wrought Copper and Wrought Alloy Solder Joint Pressure Fittings

ANSI B16.29

Wrought Copper and Wrought Alloy Solder Joint Drainage Fittings – DWV

ASTM A53

Pipe, Steel, Black and Hot-Dipped, Zinc Coated Welded and Seamless

ASTM A74

Cast Iron Soil Pipe and Fittings

ASTM A105

Forgings, Carbon Steel, for Piping Components

ASTM A126

Gray Cast Iron Castings for Valves, Flanges, and Pipe Fittings

ASTM A234

Pipe Fittings of Wrought Carbon Steel and Alloy Steel for Moderate and Elevated Temperatures

ASTM A888

Hubless Cast Iron Soil Piping and Fittings for Sanitary and Storm Drain, Waste, and Vent Piping Applications

ASTM B32

Solder Metal

ASTM B306

Copper Drainage Tube (DWV)

ASTM B813

Liquid and Paste Fluxes for Soldering Applications of Copper and Copper Alloy Tube

ASTM C564

Standard Specification for Heavy Duty Shielded Couplings Joining Hubless Cast Iron Soil Pipe and Fittings

ASTM C1540

Standard Specifications for Heavy Duty Shielded Couplings Joining Hubless Cast Iron Soil Pipe and Fittings

ASTM D1785

Poly Vinyl Chloride (PVC) Plastic Pipe (SDR Series)

ASTM D2466

Poly Vinyl Chloride (PVC) Plastic Pipe Fittings, Schedule 40

ASTM D2564

Solvent Cements for Poly Vinyl Chloride (PVC) Plastic Pipe and Fittings

ASTM D2665

Poly Vinyl Chloride (PVC) Plastic Drain, Waste and Vent Pipe and Fittings

ASTM D2729

Poly Vinyl Chloride (PVC) Sewer Pipe and Fittings

ASTM D2855

Making Solvent Cemented Joints with Poly Vinyl Chloride (PVC) Pipe and Fittings

ASTM D3034

Type PSM Poly Vinyl Chloride (PVC) Sewer Pipe and Fittings

ASTM D3139

Joints for Plastic Pressure Pipes Using Flexible Elastomeric Seals

ASTM D3212

Joints for Drain and Sewer Plastic Pipes using Flexible Elastomeric Seals

ASTM D3222

Unmodified Poly Vinylidene Fluoride (PVDF) Molding Extrusion and Coating Materials

ASTM D3311

Drain, Waste and Vent (DWV) Plastic Fitting Patterns

AWS A5.8

Brazing Filler Material

CISPI 301

Hubless Cast Iron Soil Pipe and Fittings for Sanitary and Storm Drain, Waste and Vent Piping Applications

1 CISPI 310 Couplings For Use in Connection With Hubless Cast Iron Soil Pipe and Fittings  
2 for Sanitary and Storm Drain, Waste and Vent Piping Applications.  
3

4 **SHOP DRAWINGS**

5 Schedule from the contractor indicating the ASTM or CISPI specification number of the pipe being  
6 proposed along with its type and grade if known at the time of submittal, and sufficient information to  
7 indicate the type and rating of fittings for each service.  
8

9 Statement from manufacturer on his letterhead that pipe furnished meets the ASTM or CISPI specification  
10 contained in this section.  
11

12 **QUALITY ASSURANCE**

13 Substitution of Materials: Refer to Division 1 – Basic Requirements.  
14

15 Order all copper, cast iron, steel, PVC and polyethylene pipe with each length marked with the name or  
16 trademark of the manufacturer and type of pipe; with each shipping unit marked with the purchase order  
17 number, metal or alloy designation, temper, size, and name of supplier.  
18

19 Any installed material not meeting the specification requirements must be replaced with material that meets  
20 these specifications without additional cost to the State.  
21

22 **DELIVERY, STORAGE AND HANDLING**

23 Promptly inspect shipments to insure that the material is undamaged and complies with specifications.  
24

25 Cover pipe to prevent corrosion or deterioration while allowing sufficient ventilation to avoid  
26 condensation. Do not store materials directly on grade. Protect pipe, tube and fitting ends so they are not  
27 damaged. Where end caps are provided or specified, take precautions so the caps remain in place. Protect  
28 fittings, flanges, unions by storage inside or by durable, waterproof, above ground packaging.  
29

30 Offsite storage agreements will not relieve the contractor from using proper storage techniques.  
31

32 Storage and protection methods must allow inspection to verify products.  
33

34 **DESIGN CRITERIA**

35 Use only new material, free of defects, rust and scale, and meeting the latest revision of ASTM, or CISPI  
36 specifications as listed in this specification.  
37

38 Construct all piping for the highest pressures and temperatures in the respective system.  
39

40 Non-metallic piping will be acceptable only for the services indicated. It will not be acceptable in  
41 ventilation plenum spaces, including plenum ceilings.  
42

43 Where weld fittings or mechanical grooved fittings are used, use only long radius elbows having a  
44 centerline radius of 1.5 pipe diameters.  
45

46 Where ASTM A53 type F pipe is specified, grade A type E or S, or grade B type E or S may be substituted  
47 at Contractor's option. Where the grade or type is not specified, Contractor may choose from those  
48 commercially available.  
49

50 Where ASTM B88 type L H (drawn) temper copper tubing is specified, ASTM B88, type K H (drawn)  
51 temper copper tubing may be substituted at Contractor's option.  
52

53  
54 **PART 2 – PRODUCTS**  
55

56 **SANITARY WASTE AND VENT**

- 1 INTERIOR ABOVE GROUND  
2 Hubless cast iron soil pipe and fittings, ASTM A888; with no hub couplings, CISPI 310, ASTM A74. Pipe  
3 and fittings shall be marked with the collective trademark of the Cast Iron Pipe Institute or receive prior  
4 approval of the Engineer.  
5  
6 Type M copper water tube, H (drawn) temper, ASTM B88; with cast copper drainage fittings (DMV),  
7 ANSI B16.23; wrought copper drainage fittings (DMV), ANSI B16.29; lead free(<.2%) solder, ASTM  
8 B32; flux, ASTM B813; copper phosphorus brazing alloy, AWS A5.8 BCuP. Mechanically formed brazed  
9 tee connections may be used in lieu of specified tee fittings for vent branch takeoffs up to one-half (1/2) the  
10 diameter of the main.  
11  
12 PVC plastic pipe, Schedule 40, Class 12454-B (PVC 1120), ASTM D1785; PVC plastic drain, waste and  
13 vent pipe fittings, ASTM D2665; socket fitting patterns, ASTM D3311; primer, ASTM F656; solvent  
14 cement, ASTM D2564.  
15  
16 Galvanized steel pipe, Schedule 40, Type F, Grade A, ASTM A53; with cast iron threaded drainage  
17 fittings, ASTM B16.12.  
18  
19 INTERIOR BELOW  
20 Cast iron soil piping and fittings, hub and spigot, service weight, ASTM A74, with neoprene rubber  
21 compression gaskets, ASTM C564, CISPI 301 and CISPI HSN 85. Pipe and fittings shall be marked with  
22 the collective trademark of the Cast Iron Pipe Institute.  
23  
24 PVC Plastic pipe, Schedule 40, Class 12454-B (PVC 1120), ASTM D1785; PVC plastic drain, waste and  
25 vent pipe and fittings, ASTM D2665; socket fittings patterns, ASTM D3311; primer, ASTM F656; solvent  
26 cement, ASTM D2564.  
27

### 28 PART 3 – EXECUTION

#### 29 GENERAL

30 Install pipe and fittings in accordance with reference standards, manufacturer's recommendations, and  
31 recognized industry practices.  
32

#### 33 PREPARTION

34 Cut pipe ends square. Ream ends of piping to remove burrs. Clean scale and dirt from the interior and  
35 exterior of each section of pipe and fitting prior to assembly.  
36  
37

#### 38 ERECTION

39 Install all piping parallel to building walls and ceilings and at heights which do not obstruct any portion of a  
40 window, doorway, stairway or passageway. Where interferences develop in the field, offset or reroute  
41 piping as required to clear such interferences. Coordinate locations of plumbing piping with piping,  
42 ductwork, conduit, and equipment of other trades and existing piping to allow sufficient clearances. In all  
43 cases, consult drawings for exact location of pipe spaces, ceilings heights, door and window openings, or  
44 other details before installing piping.  
45

46 Where copper or steel piping is embedded in masonry or concrete, provide protective sleeve covering of  
47 elastomeric pipe insulation.  
48

49 Maintain in clean condition internally during construction.  
50

51 Provide clearance for installation of insulation, access to valves and piping specialties.  
52

53 Provide anchors, expansion joints, swing joints and/or expansion loops so that piping may expand and  
54 contract without damage to itself, equipment, or building.  
55

1 Do not route piping through transformer vaults or above transformers, elevator equipment rooms,  
2 panelboards, or switchboards, including the required service space for this equipment, unless the piping is  
3 serving this equipment.

4  
5 Install all valves and piping specialties, including items furnished by others, as specified and/or detailed.  
6 Provide access to valves and specialties for maintenance. Make connections to all equipment, fixtures, and  
7 systems installed by others where same requires piping services indicated in this section.

#### 8 9 **COPPER PIPE JOINTS**

10 Remove all slivers and burrs remaining from the cutting operation by reaming and filing both pipe surfaces.  
11 Clean fitting and tube with metal brush, emery cloth or sandpaper. Remove residue from the cleaning  
12 operation, apply flux and assemble joint to socket stop. Apply flame to fitting until solder melts when  
13 placed at joint. Remove flame and feed solder into joint until full penetration of cup and ring of solder  
14 appears. Wipe excess solder and flux from joint.

#### 15 16 **THREADED PIPE JOINTS**

17 Use a thread lubricant or Teflon tape when making joints; no hard setting pipe thread cement or caulking  
18 will be allowed.

#### 19 20 **SOLVENT WELDED PIPE JOINTS**

21 Install in accordance with ASTM D2855 "Making Solvent Cemented Joints With PVC Pipe and Fittings".  
22 Saw cut piping square and smooth. Tube cutters may be used if they are fitted with wheels designed for  
23 use with PVC/CPVC pipe that do not leave a raised bead on pipe exterior. Support and restrain pipe during  
24 cutting to prevent nicks and scratches. Bevel ends 10-15 degrees and deburr interior. Remove any, dust,  
25 debris, moisture, grease and other superfluous materials from the pipe interior and exterior. Check dry fit  
26 of pipe and fittings. Reject materials which are out of round or do not fit within close tolerance. Use heavy  
27 body solvent cement for large diameter fittings.

28  
29 Maintain pipe, fittings, primer and cement between 40 and 100 degrees during application and curing.  
30 Apply primer and solvent using separate daubers (3" and smaller piping only) or clean natural bristle  
31 brushes about 1/2 the size of the pipe diameter. Apply primer to the fitting socket and pipe surface with a  
32 scrubbing motion. Check for penetration and reapply as needed to dissolve the surface to a depth of 4-5  
33 thousandths. Apply solvent cement to the fitting socket and pipe in an amount greater than needed to fill  
34 any gap. While both surfaces are wet, insert pipe into socket fitting with a quarter turn to the bottom of the  
35 socket. Solvent cement application and insertion must be completed in less than 1 minute. Minimum of 2  
36 installers is required on piping 4" and larger. Hold joint for 30 seconds or until set. Reference  
37 manufacturer's recommendations for ignition set time before handling and for full curing time before  
38 pressure testing. Cold weather solvent/cement may be utilized only under unusual circumstances and when  
39 specifically approved by the Owner's Project Representative.

#### 40 41 **MECHANICAL HUBLESS PIPE CONNECTIONS**

42 Place the gasket on the end of one pipe or pipe fitting and clamp the assembly on the other end of the pipe  
43 of fitting. Firmly seat the pipe or pipe fitting ends against the integrally molded shoulder inside the  
44 neoprene gasket. Slide the clamp assembly into position over the gasket. Tighten fasteners to  
45 manufacturer's recommended torque.

#### 46 47 **SANITARY WASTE AND VENT**

48 Verify invert elevations and building elevations prior to installation. Install interior piping pitched to drain  
49 at minimum slope of 1/4" per foot where possible and in no case less than 1/8" per foot for piping 3" and  
50 larger.

51  
52 Flush piping inlets (floor drains, mop basins, fixtures, etc.) with high flow of water at completion of project  
53 to demonstrate full flow capacity. Remove blockages and make necessary repairs where flow is found to  
54 be impaired.

#### 55 56 **PIPING SYSTEM LEAK TESTS**

1 Isolate or remove components from system which are not rated for test pressure. Perform final testing for  
 2 medical and lab gas with all system components in place. Test piping in sections or entire system as  
 3 required by sequence of construction. Do not insulate or conceal piping until it has been successfully  
 4 tested.  
 5  
 6 If required for the additional pressure load under test, provide temporary restraints at fittings or expansion  
 7 joints. Backfill underground water mains prior to testing with the exception of thrust restrained valves  
 8 which may be exposed to isolate potential leaks.  
 9  
 10 For hydrostatic tests, use clean water and remove all air from the piping being tests by means of air vents or  
 11 loosening of flange/unions. Measure and record test-pressure at the high point in the system.  
 12  
 13 For air or nitrogen tests, gradually increase the pressure to not more than one half of the test pressure; then  
 14 increase the pressure in steps of approximately one-tenth of the test pressure until the required test pressure  
 15 is reached. Examine all joints and connections with a soap bubble solution or equivalent method. System  
 16 will not be approved until it can be demonstrated that there is no measureable loss of test pressure during  
 17 the test period.  
 18  
 19 Inspect system for leaks. Where leaks occur, repair the area with new materials and repeat the test;  
 20 caulking will not be acceptable.  
 21 Entire test shall be witnessed by the owners representative. All pressure tests are to be documented on  
 22 forms to be provided to the contractor  
 23

24	<b>System</b>		<b>Test Medium</b>	<b>Initial Test Pressure</b>	<b>Duration</b>	<b>Final Test Pressure</b>
25	Sanitary Waste and Vent	Water	N/A	2 hr.		10' Water

26  
 27  
 28 END OF SECTION  
 29

Page Intentionally Left Blank

1  
2  
3  
4  
5  
6  
7  
8  
9  
10  
11  
12  
13  
14  
15  
16  
17  
18  
19  
20  
21  
22  
23  
24  
25  
26  
27  
28  
29  
30  
31  
32  
33  
34  
35  
36  
37  
38  
39  
40  
41  
42  
43  
44  
45  
46  
47  
48  
49  
50  
51  
52  
53

**SECTION 22 30 00**  
**PLUMBING EQUIPMENT**

**PART 1 - GENERAL**

**SCOPE**

This section includes specifications for water heaters, water softeners, pumps and other equipment used for plumbing applications. Included are the following topics:

**PART 1 - GENERAL**

- Scope
- Related Documents
- Reference
- Quality Assurance
- Shop Drawings
- Operation and Maintenance Data

**PART 2 - PRODUCTS**

- Water Heater
- Expansion Tank
- Water Softener

**PART 3 - EXECUTION**

- Installation
- Training

**RELATED DOCUMENTS**

- Section 22 05 14 – Plumbing Specialties
- Section 22 05 15 – Piping Specialties
- Section 22 05 23 - General-Duty Valves for Plumbing Piping
- Section 22 07 00 - Plumbing Insulation

**REFERENCE**

Applicable provisions of Division 1 shall govern work under this section.

**QUALITY ASSURANCE**

Substitution of Materials: Refer to Division 1 - Basic Requirements.

Plumbing products requiring approval by the State of Wisconsin Dept. of Commerce must be approved or have pending approval at the time of shop drawing submission.

**SHOP DRAWINGS**

Include data concerning dimensions, capacities, materials of construction, ratings, certifications, weights, pump curves with net positive suction head requirements, manufacturer's installation requirements, manufacturer's performance limitations, and appropriate identification.

**OPERATION AND MAINTENANCE DATA**

All operations and maintenance data shall comply with the submission and content requirements specified under Division 1 - Basic Requirements.

**PART 2 - PRODUCTS**

**ELECTRIC WATER HEATERS**

Equal to: Bradford Model LE240S3-3.

Products by A.O. Smith, Bock and Rheem are considered equal.

1 Water heater shall be a 40 gallon glass lined, with fully automatic controls, wired for 208 volt, 3 phase, and  
2 include two (2) 3000 watt elements for simultaneous operation.

3  
4 **IN-LINE CLOSE COUPLED CENTRIFUGAL PUMPS**

5 Building Circulator: B&G model NBF-9U/LW, three speed, 41 watts, single phase, 115 volts, 3GPM @ 8'  
6 HD.

7  
8 Manufacturer: Bell and Gossett, Gould, Grundfos, Taco.

9  
10 Type: Horizontal single stage close coupled oil lubricated in-line pumps, 125 psig maximum working  
11 pressure at operating temperature of 225°F. continuous. The manufacturer shall certify all pump ratings.  
12 All pumps to operate without excessive noise or vibration.

13  
14 Casing: Bronze or stainless steel; sweat suction and discharge connection.

15  
16 Impeller: Brass, bronze or thermoplastic, keyed to the shaft, single suction enclosed type, hydraulically and  
17 dynamically balanced.

18  
19 Bearings: Double-sintered carbon.

20  
21 Shaft: Ceramic.

22  
23 Seal: Mechanical type, carbon rotating against a stationary ceramic seat, 225°F maximum continuous  
24 operating temperature.

25  
26 Motor: Provide pump with open dripproof motor with built-in thermal overload protection sized for non-  
27 overloading over the entire pump curve. Furnish each pump and motor with a nameplate giving the  
28 manufacturer's name, serial number of pump, capacity in GPM and head in feet at design condition,  
29 horsepower, voltage, frequency, speed and full load current.

30  
31 Furnish and install timeclock equal to A.O. Smith Model TC-1 and Aquastat Model AQ-34.

32  
33 **EXPANSION TANKS**

34 Manufacturer: Amtrol, Bell and Gossett, Wessels.

35  
36 Equal to Amtrol model no. ST-12-C.

37  
38 Vertical steel precharged hydro-pneumatic expansion tank, 125 psi ASME labeled construction, complete  
39 with replaceable flexible butyl rubber bladder, system connection fitting, Schrader type air charge fitting,  
40 steel base ring stand, factory prime and enamel painted exterior finish, ASME relief valve. Materials  
41 exposed to water to be NSF or FDA approved for potable water service.

42  
43 **WATER SOFTENER**

44 Existing relocated to new Janitors Closet. Plumbing contractor to provided initial salt fill.

45  
46 **PART 3 - EXECUTION**

47  
48 **INSTALLATION**

49 Install plumbing equipment where indicated in accordance with manufacturer's recommendations.  
50 Coordinate equipment location with piping, ductwork, conduit and equipment of other trades to allow  
51 sufficient clearances. Locate equipment and arrange plumbing piping to provide access space for servicing  
52 all components.

53  
54 Set commercial water heater, water softener on concrete housekeeping pad. Adjust and level equipment.



1  
2 Cycle Softeners and adjust for specified exchange rate, regeneration time, consumption, backflow rate, etc.  
3  
4 Connect equipment to water and drain piping using unions or flanges and isolation valves.  
5  
6 Size temperature and relief valves per CSA ratings. Pipe temperature and pressure relief valves to hub drain  
7 or floor as indicated.  
8  
9 Startup and test equipment adjusting operating and safety controls for proper operation.  
10  
11 Lubricate pumps before startup. Adjust pumps for rated flow.  
12  
13 Adjust expansion tank precharge to scheduled minimum operating pressure prior to connecting to system.  
14  
15 **Hot Water Return Pumps**  
16 Pumps operate on signal from aquastat in hot water return line (5 feet from heater) to start on water  
17 temperature drop below 100 degrees F. and stop when temperature reaches 120 degrees F. adjustable.  
18 Furnish and mount aquastat and 24 hour timeclock. Timeclock to override aquastat control. Timeclock  
19 will allow pump to operate under control of aquastat during daytime and shut-off pump at night. Day-nite  
20 schedule set per Owner's direction. Aquastat and timeclock wiring under Division 16, Electrical.  
21  
22 **TRAINING**  
23 Provide training to designated owner personnel. Refer to Section 22 05 00  
24  
25 **END OF SECTION**

Page Intentionally Left Blank

1  
2  
3  
4  
5  
6  
7  
8  
9  
10  
11  
12  
13  
14  
15  
16  
17  
18  
19  
20  
21  
22  
23  
24  
25  
26  
27  
28  
29  
30  
31  
32  
33  
34  
35  
36  
37

**SECTION 22 42 00**  
**COMMERCIAL PLUMBING FIXTURES**

**PART 1 – GENERAL**

**SCOPE**

This section includes specifications for plumbing fixtures, faucets and trim.

**RELATED WORK**

Section 22 11 00 – Facility Water Distribution

Section 22 05 29 – Hangers and Supports for Plumbing Piping and Equipment

Section 22 05 14 – Plumbing Specialties

Section 22 05 15 – Piping Specialties

**REFERENCE**

Applicable provisions of Division 1 govern work under this section.

**QUALITY ASSURANCE**

Substitution of Materials: Refer to Division 1 – Basic Requirements.

Plumbing products requiring approval by the State of Wisconsin Dept. of Commerce must be approved or have pending approval at the time of shop drawing submittal.

**SUBMITTALS**

Include data concerning sizes, utility sizes, rough in-dimensions, capacities, materials of construction, ratings, weights, trim, finishes, manufacturer's installation requirements, manufacturer's performance limitations and appropriate identification.

**DESIGN CRITERIA**

ANSI A112.6.1M-88 – Supports for Off-the Floor Plumbing Fixtures for Public Use.

ANSI A112.19.2M-82 – Vitreous China Plumbing Fixtures.

ANSI A112.19.5-79(R1990) – Trim for Water Closet Bowls, Tanks and Urinals

ANSI A112.18.1-94-Finished Rough Brass Plumbing Fixture Fittings

**PART 2 – PRODUCTS**

**PLUMBING FIXTURES**

Manufacturers: Fixture descriptions establish fixture type, quality, materials, features and size. Products of the following manufacturers determined as equal by the Architect/Engineer will be accepted.

- Water Closets – American Standard, Kohler, Zurn, Sloan
- Flush Valves - Sloan, Zurn, Coyne & Delany
- Water Closet Seats – Bemis, Beneke, Centoco, Olsonite Sperzel.
- Lavatories – American Standard, Kohler, Zurn, Sloan
- Sinks – Elkay, Just, Bradley, Sloan
- Electric Water Coolers – Elkay, Haws, Oasis, Sunroc
- Faucets – Chicago Faucet, Kohler, Speakman, Symmons, Sloan, Zurn.
- Stops and Supplies – Chicago Faucet Co., T&S Brass, McGuire, Sioux Chief  
(Heavy Duty Type Only)
- Traps – Kohler, McGuire, Dearborn, Engineered Brass Co. (17 Gauge Min.), Sioux Chief
- Carrier and Supports – Josam, Smith, Wade, Watts Drainage, Zurn.
- Shower– Chicago, Symmons, Kohler

1 Water Closet WC-1/WC-2:  
2 Wall hung, back outlet, white vitreous siphon jet water closet with elongated bowl, 1-1/2" top  
3 spud, 2-5/2" passageway, 1.6 gallon flush, white open front seat, less cover, battery powered  
4 sensor operated flush valve.  
5  
6 Fixture: Kohler "Kingston" K-4330  
7  
8 Flush Valve: Sloan "royal" Model 111. Battery powered sensor activated.  
9  
10 Seat: Bemis 1055SSC self-sustaining concealed check hinge.  
11  
12 Carrier: Commercial grade for a minimum of 650 pound support. Install WC-2 @ 17" to rim.  
13

14 Urinals U-1/U-2:  
15 Wall hung, white china washout urinal with 3/4" top spud, 2" outlet, removable beehive strainer and 1 gallon  
16 flush. Battery powered sensor operated flush valve.  
17 Fixture: Kohler "Bardon" K-4960-T  
18 Flush Valve: Sloan 8186-1  
19 Smith commercial grad adjusted for 24" lip height for U-1 and 17" for U-2.  
20

21 Lavatory L-1:  
22 Wall hung, natural quartz with 4" on center faucet openings with deck mounted single handle  
23 operated faucet.  
24  
25 Fixture: Bradley LVS Series – Two (2) Station.  
26  
27 Carrier: Mounted on bracket assembly.  
28  
29 Faucet: Chicago Faucet Model 2200-4E2805.  
30  
31 Drain: Kohler L-13885 open grid perforated strainer, and 1-1/4" offset tailpiece.  
32  
33 Trap: 1-1/4" x 1-1/2" 176A cast brass.  
34  
35 Supplies & Stops: McGuire BV07 with loose key handles.  
36

37 Lavatory L-2  
38 Same as L-1, except Three (3) Station.  
39

40 Sink S-1:  
41 Counter mounted 18 Ga. Type 302 stainless steel single compartment sink with 3 faucet openings  
42 4" on center, deck mounted single handle faucet with pullout spray spout.  
43  
44 Fixture: Elkay LK-2219  
45  
46 Faucet: Kohler "Simplice" K-597.  
47  
48 Drain: Elkay  
49  
50 Water Filter: PS Filtration Products Model PS150437.  
51  
52 Trap: 1-1/2" x 1-1/2" 17 GA. Cast brass.  
53  
54 Garbage disposer: Insinkerator "Badger" 5xp, 3/4 hp.  
55  
56 Supplies & Stops: McGuire H2165LK with loose key handles.

1  
2  
3  
4  
5  
6  
7  
8  
9  
10  
11  
12  
13  
14  
15  
16  
17  
18  
19  
20  
21  
22  
23  
24  
25  
26  
27  
28  
29  
30  
31  
32  
33  
34  
35  
36  
37  
38  
39  
40  
41  
42  
43  
44  
45  
46  
47  
48  
49  
50  
51  
52  
53  
54  
55  
56

Hot water dispenser: Insinkerator model C1300.

Sink S-2:

Same as sink S-1 (less water filter) except provided Elkay model DLR221910 sink.

Mop Basin:

MB-1: Floor mounted polyester resin and stone mop basin, 24"x24" with 3" drain, stainless steel strainer and vinyl bumper guards, mixing faucet with spout brace, pail hook, hose threaded outlets, and mop hanger. Provide a code approved tee fitting for chemical dispensing unit.

Chemical Dispensing unit provided by owner:

- Fixture: Mustee Model 63M
- Faucet: Kohler K8907-RP with watts 8A vacuum breaker
- Hose: Mustee 65.700 with wall bracket
- Bumper Guards: Mustee 63.401 and 65.403.
- Mop Hangar: Mustee 65.600

Electric Water Cooler EWC-1:

Wall mounted barrier free electric water cooler with exposed stainless steel basin, water filter, self closing front front/side push button, wall hanger and 1-1/4" tailpiece rated for 8.0 GPH at 80 degree inlet water, 80 degree ambient and 50 degree leaving water, 380 watts, 4.5 FLA, 120/60/1. Include Elkay model EZH20 bottle filling station.

Fixture: Elkay Model LZSG8WSSK.

Trap: 1-1/4" x 1-1/4" 17 GA. Cast brass trap

Supplies & Stop: Accessible 1/2" ball valve with 1/2" riser (concealed).

Eye/Face Wash-EFW-1

Haws Model 7324 with Haws model 9201EF thermostatic mixing valve.

**PART 3 – EXECUTION**

**INSTALLATION**

Verify the existing water closet rough-in dimensions before ordering new units.

Install all plumbing fixtures in accordance with manufacturer's instructions. Set level and plumb. Secure in place to counters, floors and walls providing solid bearing and secure mounting. Bolt fixture carriers to floor and wall. Secure rough-in fixture piping to prevent movement exposed piping.

Install each fixture with trap easily removable for servicing and cleaning. Install fixture stops in readily accessible location for servicing.

Install barrier free fixtures in compliance with IBC 1108 and 3408, COMM 69 and Federal ADA Accessibility guidelines. Install barrier free lavatory traps parallel and adjacent to wall and supplies and stops elevated to avoid contact by wheelchair users.

Each fixture shall have a stop valve installation to control the fixture. Stop valves shall be heavy duty type with brass stems and screwed or sweat inlet connections. Compression type inlets are not acceptable.

Cover pipe penetrations with escutcheons. Exposed traps, stops, piping and escutcheons to be chrome plated brass, same items in concealed locations may be of rough brass finish.

Seal openings between walls, floors and fixtures with mildew-resistant silicone sealant same color as fixture.

1  
2  
3  
4  
5  
6  
7  
8  
9

Test fixtures to demonstrate proper operation. Replace malfunctioning units or components. Adjust valves for intended water flow rate to fixtures without splashing, noise or overflow.

Protect fixtures during construction. At completion clean plumbing fixtures and trim using manufacturer's recommended cleaning methods and materials.

END OF SECTION



Page Intentionally Left Blank



1  
2  
3  
4  
5  
6  
7  
8  
9  
10  
11  
12  
13  
14  
15  
16  
17  
18  
19  
20  
21  
22  
23  
24  
25  
26  
27  
28  
29  
30  
31  
32  
33  
34  
35  
36  
37  
38  
39  
40  
41  
42  
43  
44  
45  
46  
47  
48  
49  
50  
51  
52  
53  
54  
55  
56  
57  
58  
59  
60  
61  
62  
63  
64

**SECTION 23 05 00**  
**COMMON WORK RESULTS FOR HVAC**

**PART 1 - GENERAL**

**SCOPE**

This section includes information common to two or more technical specification sections or items that are of a general nature, not conveniently fitting into other technical sections.

**RELATED WORK**

Section 23 05 13 - Common Motor Requirements for HVAC.  
Section 23 33 00 - Air Duct Accessories.

**REFERENCE**

Applicable provisions of Division 00 - Contracting Requirements and Division 01- General Requirements govern work under all Division 23 Sections.

**REFERENCE STANDARDS**

Abbreviations of standards organizations referenced in other sections are as follows:

AABC	Associated Air Balance Council
ADC	Air Diffusion Council
AAMCA	Air Movement and Control Association
ANSI	American National Standards Institute
ARI	Air-Conditioning and Refrigeration Institute
ASHRAE	American Society of Heating, Refrigerating and Air Conditioning Engineers
ASME	American Society of Mechanical Engineers
ASTM	American Society for Testing and Materials
EPA	Environmental Protection Agency
IEEE	Institute of Electrical and Electronics Engineers
ISA	Instrument Society of America
MCA	Mechanical Contractors Association
MICA	Midwest Insulation Contractors Association
MSS	Manufacturer's Standardization Society of the Valve & Fitting Industry, Inc.
NBS	National Bureau of Standards
NEBB	National Environmental Balancing Bureau
NEC	National Electric Code
NEMA	National Electrical Manufacturers Association
NFPA	National Fire Protection Association
SMACNA	Sheet Metal and Air Conditioning Contractors' National Association, Inc.
UL	Underwriters Laboratories Inc.
ASTM E814	Standard Test Method for Fire Tests of Through-Penetration Fire Stops
ASTM E84	Standard Test Method for Surface Burning Characteristics of Building Materials
UL1479	Fire Tests of Through-Penetration Firestops
UL723	Surface Burning Characteristics of Building Materials

**QUALITY ASSURANCE**

Refer to Division 01, General Requirements, Equals and Substitutions.

Where equipment or accessories are used which differ in arrangement, configuration, dimensions, ratings, or engineering parameters from those indicated on the contract documents, the contractor is responsible for all costs involved in integrating the equipment or accessories into the system and for obtaining the performance from the system into which these items are placed. This may include changes found necessary during the testing, adjusting, and balancing phase of the project.

**PROTECTION OF FINISHED SURFACES**

Refer to Division 01, General Requirements, Protection of Finished Surfaces.

Furnish one can of touch-up paint for each different color factory finish which is to be the final finished surface of the product. Deliver touch-up paint with other "loose and detachable parts" as covered in the General Requirements.

**SLEEVES AND OPENINGS**

Refer to Division 01, General Requirements, Sleeves and Openings.

1  
2  
3 **SEALING AND FIRE STOPPING**

4 Sealing and fire stopping of sleeves/openings between ductwork, piping, etc. and the sleeve, structural or  
5 partition opening shall be the responsibility of the contractor whose work penetrates the opening. Provide  
6 all fire stopping of fire rated penetrations and sealing of smoke rated penetrations in compliance with section  
7 07 84 00 Fire Stopping.  
8

9 **SUBMITTALS**

10 Refer to Division 01, General Requirements, Submittals.

11  
12 Submit for all equipment and systems as indicated in the respective specification sections, marking each  
13 submittal with that specification section number. Mark general catalog sheets and drawings to indicate  
14 specific items being submitted and proper identification of equipment by name and/or number, as indicated  
15 in the contract documents.  
16

17 Before submitting electrically powered equipment, verify that the electrical power and control requirements  
18 for the equipment are in agreement with the electrical drawings. Include a statement on the shop drawing  
19 transmittal to the architect/engineer that the equipment submitted and the motor starter schedules are in  
20 agreement or indicate any discrepancies. See related comments in Section 23 05 13 in Part 1 under Electrical  
21 Coordination.  
22

23 Include wiring diagrams of electrically powered equipment.

24  
25 Submit sufficient quantities of shop drawings to allow the following distribution:

- 26 • Operating and Maintenance Manuals 2 copies
- 27 • Testing, Adjusting and Balancing Contractor 1 copy
- 28 • Owner 1 copy
- 29 • A/E 1 copy
- 30
- 31 • Electronic copies may be submitted in lieu of paper copies. Entire submittal may not be  
32 returned, only a Submittal Review Form with status of the submittal and any comments and  
33 potentially selected sheets of the submittal with comments noted.  
34

35 **CERTIFICATES AND INSPECTIONS**

36 Refer also to Division 01, General Requirements, Permits, Regulations, Utilities and Taxes.  
37

38 Obtain and pay for all required State installation inspections except those provided by the Architect/Engineer  
39 in accordance with code. Deliver originals of these certificates to the Division Project Representative.  
40 Include copies of the certificates in the Operating and Maintenance Instructions.  
41

42 **OPERATION AND MAINTENANCE DATA**

43 All operations and maintenance data shall comply with the submission and content requirements specified  
44 under section GENERAL REQUIREMENTS.  
45

46 In addition to the general content specified under GENERAL REQUIREMENTS supply the following  
47 additional documentation:

- 48 1. Records of tests performed to certify compliance with system requirements
- 49 2. Certificates of inspection by regulatory agencies
- 50 3. Valve schedules
- 51 4. Lubrication instructions, including list/frequency of lubrication
- 52 5. Copies of all approved shop drawings.
- 53 6. Manufacturer's wiring diagrams for electrically powered equipment
- 54 7. Temperature control record drawings and control sequences
- 55 8. Parts lists for manufactured equipment
- 56 9. Warranties
- 57 10. Additional information as indicated in the technical specification sections  
58

59 **TRAINING OF OWNER PERSONNEL**

60 Instruct owner personnel in the proper operation and maintenance of systems and equipment provided as part  
61 of this project. Include not less than one hour of instruction, using the Operating and Maintenance manuals  
62 during this instruction. Demonstrate startup and shutdown procedures for all equipment. All training to be  
63 during normal working hours.  
64

1 **RECORD DRAWINGS**

2 Refer to Division 01, General Requirements, Record Drawings.

3  
4 In addition to the data indicated in the General Requirements, maintain temperature control record drawings  
5 on originals prepared by the installing contractor/subcontractor. Include copies of these record drawings with  
6 the Operating and Maintenance manuals.  
7

8  
9 **PART 2 - PRODUCTS**

10 **ACCESS PANELS AND DOORS**

11 **LAY-IN CEILINGS:**

12  
13 Removable lay-in ceiling tiles in 2 X 2 foot or 2 X 4 foot configuration provided under Section 09500 are  
14 sufficient; no additional access provisions are required unless specifically indicated.  
15

16 **GYPSUM WALL BOARD WALLS AND CEILINGS:**

17  
18 16 gauge frame with not less than a 20 gauge hinged door panel, prime coated steel for general applications,  
19 stainless steel for use in toilets, showers, and similar wet areas, concealed hinges, screwdriver operated cam  
20 latch for general applications, key lock for use in public areas, UL listed for use in fire rated partitions if  
21 required by the application. Use the largest size access opening possible, consistent with the space and the  
22 equipment needing service; minimum size is 12" by 12".  
23

24 **IDENTIFICATION**

25 **STENCILS:**

26 Not less than 1 inch high letters/numbers for marking pipe and equipment.  
27

28 **SNAP-ON PIPE MARKERS:**

29 Cylindrical self-coiling plastic sheet that snaps over piping insulation and is held tightly in place without the  
30 use of adhesive, tape or straps. Not less than 1 inch high letters/numbers and flow direction arrows for piping  
31 marking. W. H. Brady, Seton, Marking Services, or equal.  
32

33 **ENGRAVED NAME PLATES:**

34 White letters on a black background, 1/16 inch thick plastic laminate, beveled edges, screw mounting,  
35 Setonply Style 2060 by Seton Name Plate Company or Emedolite- Style EIP by EMED Co., or equal by  
36 Marking Services, or W. H. Brady.  
37

38 **SEALING**

39 **NON-RATED PENETRATIONS:**

40 **Pipe Penetrations:**

41  
42 At pipe penetrations of non-rated interior walls, floors and exterior walls above grade, use urethane caulk in  
43 annular space between pipe insulation and sleeve. For non-rated drywall, plaster or wood walls where sleeve  
44 is not required use urethane caulk in annular space between pipe insulation and wall material.  
45

46 **Duct Penetrations:**

47  
48 Annular space between duct (with or without insulation) and the non-rated walls or floor opening shall not  
49 be larger than 2". Where existing openings have an annular space larger than 2", the space shall be patched  
50 to match existing construction to within 2" around the duct.  
51

52 Where shown or specified, pack annular space with fiberglass batt insulation or mineral wool insulation.  
53 Provide 4" sheet metal escutcheon around duct on both sides of partition or floor to cover annular space.  
54

55  
56 **PART 3 - EXECUTION**

57 **DEMOLITION**

58 Perform all demolition as indicated on the drawings to accomplish new work.

59 All pipe, wiring and associated conduit, insulation, ductwork, and similar items demolished, abandoned, or  
60 deactivated are to be removed from the site by the Contractor. All piping and ductwork specialties are to be  
61 removed from the site by the Contractor unless they are dismantled and removed or stored by the owner  
62 Maintain the condition of material and/or equipment that is indicated to be reused equal to that existing before  
63 work began.  
64

1  
2  
3  
4  
5  
6  
7  
8  
9  
10  
11  
12  
13  
14  
15  
16  
17  
18  
19  
20  
21  
22  
23  
24  
25  
26  
27  
28  
29  
30  
31  
32  
33  
34  
35  
36  
37  
38  
39  
40  
41  
42  
43  
44  
45  
46  
47

**CUTTING AND PATCHING**

Refer to Division 01, General Requirements, Cutting and Patching.

**BUILDING ACCESS**

Arrange for the necessary openings in the building to allow for admittance of all apparatus.

**EQUIPMENT ACCESS**

Install all piping, conduit, ductwork, and accessories to permit access to equipment for maintenance and service.

**COORDINATION**

Verify that all devices are compatible for the surfaces on which they will be used. This includes, but is not limited to, diffusers, register, grilles, and recessed or semi-recessed heating and/or cooling terminal units installed in/on architectural surfaces.

Coordinate all work with other contractors prior to installation. Any installed work that is not coordinated and that interferes with other contractor's work shall be removed or relocated at the installing contractor's expense.

Cooperate with the test and balance agency in ensuring Section 23 05 93 specification compliance. Verify system completion to the test and balance agency (flushing, pressure testing, chemical treatment, filling of liquid systems, proper pressurization and air venting of hydronic systems, clean filters, clean strainers, duct and pipe systems cleaned, controls adjusted and calibrated, controls cycled through their sequences, etc.), ready for testing, adjusting and balancing work. Install dampers, shutoff and balancing valves, flow measuring devices, gauges, temperature controls, etc., required for functional and balanced systems.

**IDENTIFICATION**

Identify piping not less than once every 30 feet, not less than once in each room, adjacent to each access door or panel, and on both side of the partition where exposed piping passes through walls, floors or roofs. Place flow directional arrows at each pipe identification location.

**LUBRICATION**

Lubricate all bearings with lubricant as recommended by the manufacturer before the equipment is operated for any reason. Once the equipment has been run, maintain lubrication in accordance with the manufacturer's instructions. Maintain a log of all lubricants used and frequency of lubrication; include this information in the Operating and Maintenance Manuals at the completion of the project.

**DUCT SLEEVES:**

Duct sleeves are not required in non-rated partitions or floors.

END OF SECTION

1  
2  
3  
4  
5  
6  
7  
8  
9  
10  
11  
12  
13  
14  
15  
16  
17  
18  
19  
20  
21  
22  
23  
24  
25  
26  
27  
28  
29  
30  
31  
32  
33  
34  
35  
36  
37  
38  
39  
40  
41  
42  
43  
44  
45  
46  
47  
48  
49  
50  
51  
52  
53  
54  
55  
56  
57  
58  
59  
60  
61  
62  
63  
64  
65  
66  
67

**SECTION 23 05 13**  
**COMMON MOTOR REQUIREMENTS FOR HVAC EQUIPMENT**

**PART 1 - GENERAL**

**SCOPE**

This sections includes requirements for single phase motors that are used with equipment specified in other sections.

**RELATED WORK**

Section 23 09 14 - Electric Instrumentation and Control Devices for HVAC  
Section 23 34 00 - Fans  
Section 23 82 00 - Heating Terminal Units  
Division 26 00 00 - Electrical

**REFERENCE**

Applicable provisions of Division 01, General Requirements govern work under this section.

**REFERENCE STANDARDS**

ANSI/IEEE 112 Test Procedure for Polyphase Induction Motors and Generators  
ANSI/NEMA MG-1 Motors and Generators  
ANSI/NFPA 70 National Electrical Code

**QUALITY ASSURANCE**

Refer to Division 01, General Requirements, Equals and Substitutions.

**SHOP DRAWINGS**

Refer to Division 01, General Requirements, Submittals.

Include with the equipment which the motor drives the following motor information: motor manufacturer, horsepower, voltage, phase, hertz, rpm, full load efficiency. Include project wiring diagrams prepared by the contractor specifically for this work.

**ELECTRICAL COORDINATION**

All starters, overload relay heater coils, disconnect switches and fuses, relays, wire, conduit, pushbuttons, pilot lights, and other devices required for the control of motors or electrical equipment are furnished and installed by the Electrical Contractor, except as specifically noted elsewhere in this division of specifications.

Electrical drawings and/or specifications show number and horsepower rating of all motors furnished by this Contractor, together with their actuating devices if these devices are furnished by the Electrical Contractor. Should any discrepancy in size, horsepower rating, electrical characteristics or means of control be found for any motor or other electrical equipment after contracts are awarded, Contractor is to immediately notify the architect/engineer of such discrepancy. Costs involved in any changes required due to equipment substitutions initiated by this contractor will be the responsibility of this contractor.

Electrical Contractor will provide all power wiring and control wiring, except temperature control wiring.

Furnish project specific wiring diagrams to Electrical Contractor for all equipment and devices furnished by this Contractor and indicated to be wired by the Electrical Contractor.

**PRODUCT CRITERIA**

Motors to conform to all applicable requirements of NEMA, IEEE, ANSI, and NEC standards and shall be listed by U.L. for the service specified.

**PART 2 - PRODUCTS**

**SINGLE PHASE, SINGLE SPEED MOTORS**

Use NEMA rated 115 volt, single phase, 60 hertz motors for all motors 1/3 HP and smaller.

Use permanent split capacitor or capacitor start, induction run motors equipped with permanently lubricated and sealed ball or sleeve bearings and Class A insulation. Service factor to be not less than 1.35.

1  
2  
3  
4  
5  
6  
7  
8  
9  
10  
11  
12  
13  
14  
15  
16  
17  
18  
19

**PART 3 - EXECUTION**

**INSTALLATION**

Mount motors on a rigid base designed to accept a motor, using shims if required under each mounting foot to get a secure installation.

When motor will be connected to the driven device by means of a belt drive, mount sheaves on the appropriate shafts in accordance with the manufacturer's instructions. Use a straight edge to check alignment of the sheaves; reposition sheaves as necessary so that the straight edge contacts both sheave faces squarely. After sheaves are aligned, loosen the adjustable motor base so that the belt(s) can be added and tighten the base so that the belt tension is in accordance with the drive manufacturer's recommendations. Frequently recheck belt tension and adjust if necessary during the first day of operation and again after 80 hours of operation.

Lubricate all motors requiring lubrication. Record lubrication material used and the frequency of use. Include this information in the maintenance manuals.

END OF SECTION

1  
2  
3  
4  
5  
6  
7  
8  
9  
10  
11  
12  
13  
14  
15  
16  
17  
18  
19  
20  
21  
22  
23  
24  
25  
26  
27  
28  
29  
30  
31  
32  
33  
34  
35  
36  
37  
38  
39  
40  
41  
42  
43  
44  
45  
46  
47  
48  
49  
50  
51  
52  
53  
54  
55  
56  
57  
58  
59

**SECTION 23 05 15**  
**PIPING SPECIALTIES**

**PART 1 - GENERAL**

**SCOPE**

This section contains specifications for HVAC piping specialties for all piping systems

**RELATED WORK**

Section 23 21 13 - Hydronic Piping

Section 23 05 23 - General-Duty Valves for HVAC Piping

Section 23 05 29 - Hangers and Supports for HVAC Piping and Equipment

Section 23 07 00 - HVAC Insulation

**REFERENCE**

Applicable provisions of Division 01, General Requirements govern work under this section.

**QUALITY ASSURANCE**

Refer to Division 01, General Requirements, Equals and Substitutions.

**SHOP DRAWINGS**

Refer to Division 01, General Requirements, Submittals.

Required for all items in this section; Include materials of construction, dimensional data, ratings/capacities/ranges, pressure drop data where appropriate, and identification as referenced in this section and/or on the drawings.

**OPERATION AND MAINTENANCE DATA**

All operations and maintenance data shall comply with the submission and content requirements specified under section GENERAL REQUIREMENTS.

**DESIGN CRITERIA**

All piping specialties are to be rated for the highest pressures and temperatures in the respective system in accordance with ANSI B31, but not less than 125 psig unless specifically indicated otherwise.

**PART 2 - PRODUCTS**

**HOSE CONNECTION CAPS**

Hose connection caps shall be pressure rated for 150 psig at 180 deg F.

**AIR VENTS**

**MANUAL KEY TYPE VENTS:**

Bell and Gossett Model 4V; Eaton/Dole Model 9, 9B, or 14A.

Bronze body with nonferrous internal parts, screwdriver operated, designed to relieve air from the system when vent is opened, rated at not less than 125 psig at 220°F.

**MANUAL BALL VALVE VENTS:**

Provide 1/4" ball valves for manual venting of air handling unit coils and where indicated elsewhere on drawings and details. Reference specifications section 23 05 23.

**PART 3 - EXECUTION**

1  
2  
3  
4  
5  
6  
7  
8  
9  
10  
11  
12  
13  
14

**AIR VENTS**

**MANUAL KEY TYPE VENTS:**

Install at all high points where air may collect and not be carried by the system fluid. Use a soft Type L copper "pigtail" so the vent can be positioned for venting and collecting any water that might escape.

**MANUAL BALL VALVE VENTS:**

Install where indicated elsewhere as shown on drawings and details.

END OF SECTION



1  
2  
3  
4  
5  
6  
7  
8  
9  
10  
11  
12  
13  
14  
15  
16  
17  
18  
19  
20  
21  
22  
23  
24  
25  
26  
27  
28  
29  
30  
31  
32  
33  
34  
35  
36  
37  
38  
39  
40  
41  
42  
43  
44  
45  
46  
47  
48  
49  
50  
51  
52  
53  
54  
55  
56  
57  
58  
59  
60  
61  
62

**SECTION 23 05 23  
GENERAL-DUTY VALVES FOR HVAC PIPING**

**PART 1 - GENERAL**

**SCOPE**

This section includes valve specifications for all HVAC systems except where indicated under Related Work.

**RELATED WORK**

- Section 23 05 15 - Piping Specialties
- Section 23 05 15 - Hydronic Piping
- Section 23 05 15 - Heating Terminal Units

**REFERENCE**

Applicable provisions of Division 01, General Requirements govern work under this section.

**QUALITY ASSURANCE**

Refer to Division 01, General Requirements, Equals and Substitutions.

**SUBMITTALS**

Refer to Division 01, General Requirements, Submittals.  
Contractors shall submit a schedule of all valves indicating type of service, dimensions, materials of construction, and pressure/temperature ratings for all valves to be used on the project. Temperature ratings specified are for continuous operation.

**OPERATION AND MAINTENANCE DATA**

All operations and maintenance data shall comply with the submission and content requirements specified under section GENERAL REQUIREMENTS.

**DESIGN CRITERIA**

Where valves are specified for individual mechanical services (i.e. hot water heating, steam, etc.) all valves shall be of the same manufacturer. .

**PART 2 - PRODUCTS**

**MANUFACTURERS**

Refer to manufacturers listed at each valve type.

**WATER SYSTEM VALVES**

All water system valves to be rated at not less than 125 psig water working pressure at 240°F unless noted otherwise.

**BALL VALVES:**

2-1/2" and smaller: Two piece bronze body; threaded or soldered ends, as appropriate to the pipe material; stainless steel or chrome plated brass/bronze ball; conventional port; glass filled teflon seat; threaded packing gland follower; blowout-proof stem; 600 psig WOG.

Valve stems shall allow operators to clear insulation without interference. Provide stem extensions when valve operators interfere with pipe insulation.

Apollo 70-100/200 series, Hammond 8301/8311, Milwaukee BA100/150, Nibco T/S 585-70, Stockham S206/216 or approved equal.

**BALANCE VALVES:**

2" and smaller: Bronze or copper alloy body with calibrated ball, globe or venturi/valve arrangement, integral pointer and calibrated scale to register degree of valve opening, memory stop, drain tapping, threaded or soldered ends, with or without integral unions, P/T or Shraeder pressure taps with integral check valves and seals, adjustable memory stop, suitable for 200 psig water working pressure at 250°F.

1 Armstrong CBV, Bell & Gossett Circuit Setter Plus, Griswold Quickset, Nexus Orturi, Nibco 1710 Series,  
2 Taco Accu-Flo, Tour & Anderson STAS/STAD, Victaulic series 786/787 or approved equal.

3  
4 **DRAIN VALVES:**

5 Use 3/4 inch ball valve with threaded hose adapter except strainer blowdown valves to be the same size as  
6 the blowdown connection. Provide hose connection caps pressure rated for 150 psig at 180 deg F.

7  
8  
9 **PART 3 - EXECUTION**

10  
11 **GENERAL**

12 Properly align piping before installation of valves in an upright position; operators installed below the valves  
13 will not be accepted.

14  
15 Install valves in strict accordance with valve manufacturer's installation recommendations. Do not support  
16 weight of piping system on valve ends.

17  
18 Install all temperature control valves.

19  
20 Install all valves with the stem in the upright position. Valves may be installed with the stem in the horizontal  
21 position only where space limitations do not allow installation in an upright position or where large valves  
22 are provided with chain wheel operators.

23  
24 **SHUT-OFF VALVES**

25 Install shut-off valves at all equipment, at each branch take-off from mains, and at each automatic valve for  
26 isolation or repair.

27  
28 **BALANCING VALVES**

29 Provide balancing valves for all equipment as indicated on drawings and details.

30  
31 **CALIBRATED BALANCE VALVES**

32 Install where indicated on the drawings and details for balancing of hydronic systems. Retain the shipping  
33 container for use as removable insulation.

34  
35 **DRAIN VALVES**

36 Provide drain valves for complete drainage of all systems. Locations of drain valves include low points of  
37 piping systems, equipment locations specified or detailed including reheat coils, other locations required for  
38 drainage of systems.

39  
40  
41 **END OF SECTION**

1  
2  
3  
4  
5  
6  
7  
8  
9  
10  
11  
12  
13  
14  
15  
16  
17  
18  
19  
20  
21  
22  
23  
24  
25  
26  
27  
28  
29  
30  
31  
32  
33  
34  
35  
36  
37  
38  
39  
40  
41  
42  
43  
44  
45  
46  
47  
48  
49  
50  
51  
52  
53

**SECTION 23 05 29**  
**HANGERS AND SUPPORTS FOR HVAC PIPING AND EQUIPMENT**

**PART 1 - GENERAL**

**SCOPE**

This section includes specifications for supports of all HVAC equipment and materials.

**RELATED WORK**

Section 23 07 00 - HVAC Insulation

**REFERENCE**

Applicable provisions of Division 01, General Requirements shall govern work under this section.

**REFERENCE STANDARDS**

MSS SP-58 Materials, Design, Manufacture, Selection, Application, and Installation

**QUALITY ASSURANCE**

Refer to Division 01, General Requirements, Equals and Substitutions.

**DESCRIPTION**

Provide all supporting devices as required for the installation of mechanical equipment and materials. All supports and installation procedures are to conform to the latest requirements of the ANSI Code for pressure piping.

Do not hang any mechanical item directly from a metal deck or run piping so it rests on the bottom chord of any truss or joist.

Support apparatus and material under all conditions of operation, variations in installed and operating weight of equipment and piping, to prevent excess stress, and allow for proper expansion and contraction.

Protect insulation at all hanger points; see Related Work above.

**SHOP DRAWINGS**

Refer to Division 01, General Requirements, Submittals.

Schedule of all hanger and support devices indicating shields, attachment methods, and type of device for each pipe size and type of service. Reference section 23 05 00.

**DESIGN CRITERIA**

Materials and application of pipe hangers and supports shall be in accordance with MSS Standard Practice SP-58 unless noted otherwise.

Piping supported by laying on the bottom chord of joists or trusses will not be accepted.

Fasteners depending on soft lead for holding power or requiring powder actuation will not be accepted.

Allow sufficient space between adjacent pipes and ducts for insulation, valve operation, routine maintenance, etc.

**PART 2 - PRODUCTS**

**PIPE HANGER AND SUPPORT MANUFACTURERS**

Anvil, B-Line, Fee and Mason, Kindorf, Michigan Hanger, Unistrut, or approved equal. Anvil figure numbers are listed below; equivalent material by other manufacturers is acceptable.

**STRUCTURAL SUPPORTS**

Provide all supporting steel required for the installation of mechanical equipment and materials, whether or not it is specifically indicated or sized, including angles, channels, beams, etc. to suspend or floor support tanks and equipment.

**PIPE HANGERS AND SUPPORTS**

HANGERS FOR STEEL PIPE SIZES 1/2" THROUGH 2":

Carbon steel, adjustable, clevis, black finish. Anvil figure 65 or 260.

1  
2 **COPPER PIPE SUPPORT:**  
3 Carbon steel ring, adjustable, copper plated or polyvinylchloride coated.

4  
5 **INSULATION PROTECTION SHIELDS:**  
6 Galvanized carbon steel of not less than 18 gauge for use on insulated pipe 2-1/2 inch and larger.  
7 Minimum shield length is 12 inches. Equal to Anvil figure 167.

8  
9 **STEEL HANGER RODS:**  
10 Threaded both ends, threaded one end, or continuous threaded, black finish.

11  
12 Size rods for individual hangers and trapeze support as indicated in the following schedule.

13  
14 Total weight of equipment, including valves, fittings, pipe, pipe content, and insulation, are not to exceed  
15 the limits indicated.

Maximum Load (Lbs.) (650°F Maximum Temp.)	Rod Diameter (inches)
610	3/8

16  
17  
18  
19  
20 Provide rods complete with adjusting and lock nuts.

21  
22 **BEAM CLAMPS**

23 MSS SP-58 Type 23 malleable black iron clamp for attachment to beam flange to 0.62 inches thick for  
24 single threaded rods of 3/8, 1/2, and 5/8 inch diameter, for use with pipe sizes 4 inch and less. Furnish with  
25 a hardened steel cup point set screw. Anvil figure 86.

26  
27 MSS SP-58 Type 28 or Type 29 forged steel jaw type clamp with a tie rod to lock clamp in place, suitable  
28 for rod sizes to 1-1/2 inch diameter but limited in application to pipe sizes 8 inch and less without prior  
29 approval. Anvil figure 228.

30  
31 **EQUIPMENT CURBS**

32 Refer to Section 23 34 00 – HVAC Fans for curbs specified to be provided for power roof exhausters

33  
34  
35 **PART 3 - EXECUTION**

36  
37 **INSTALLATION**

38 Install supports to provide for free expansion of the piping and duct system. Support all piping from the  
39 structure using concrete inserts, beam clamps, ceiling plates, wall brackets, or floor stands. Fasten ceiling  
40 plates and wall brackets securely to the structure and test to demonstrate the adequacy of the fastening.

41  
42 Piping shall be supported independently from ductwork and all other trades.

43  
44 **HANGER AND SUPPORT SPACING**

45 Place a hanger within 12 inches of each horizontal elbow, valve, strainer, or similar piping specialty item.

46  
47 Adjust hangers to obtain the slope specified in the piping section of this specification.

48  
49 Space hangers for pipe as follows:

Pipe Material	Pipe Size	Max. Spacing
Steel	1/2" through 1-1/4"	6'-6"
Copper	1/2" through 1-1/4"	5'-0"

50  
51  
52  
53  
54  
55 **EQUIPMENT CURBS**

56 Secure bottom of support flat on roof deck. Secure equipment to curb in accordance with equipment  
57 manufacturer's instructions. Flashing and counter flashing by the Division 07 Contractor.

58  
59 Fill the entire void space with compressible fiberglass insulation.

60  
61  
62 **END OF SECTION**

1  
2  
3 **SECTION 23 05 93**  
4 **TESTING, ADJUSTING, AND BALANCING FOR HVAC**

5  
6  
7 **PART 1 - GENERAL**

8 **SCOPE**

9 This section includes air and water testing, adjusting and balancing for equipment installed or reinstalled as  
10 part of this project including VAV terminals, hot water radiation, cabinet unit heaters and exhaust fans.

11 **RELATED WORK**

12 Section 23 05 00 - Common Work Results for HVAC  
13 Section 23 07 00 - HVAC Insulation  
14 Section 23 09 14 - HVAC Control  
15 Section 23 09 93 - Sequence of Operation for HVAC Controls  
16 Section 23 34 00 - Fans  
17 Section 23 82 00 - Heating Terminal Units

18  
19 **REFERENCE**

20 Applicable provisions of Division 01, General Requirements govern work under this section.

21  
22 **REFERENCE STANDARDS**

23 AABC National Standards for Total System Balance, Sixth Edition, 2002.  
24 ASHRAE ASHRAE Handbook, 2007 HVAC Applications, Chapter 37, Testing Adjusting and  
25 Balancing.  
26 NEBB Procedural Standards for Testing Adjusting Balancing of Environmental Systems, Seventh  
27 Edition, 2005.  
28 TABB Tab Procedural Guide, First Edition, 2003.

29  
30 **DESCRIPTION**

31 The Contractor will separately contract with an independent test and balance agency to perform all testing,  
32 adjusting, and balancing of air and hydronic systems required for this project. Work related to the testing,  
33 adjusting, and balancing that must be performed by the installing mechanical contractor is specified in other  
34 section of these specifications.

35  
36 Provide mechanical systems testing, adjusting and balancing as described in this section and indicated on  
37 the drawings. Requirements include the balance of air and water distribution, adjustment of new and existing  
38 systems and equipment to provide design requirements indicated on the drawings, electrical measurement  
39 and verification of performance of all mechanical equipment, all in accordance with standards published by  
40 AABC, NEBB, or TABB.

41  
42 Test, adjust and balance all air and hydronic systems so that each room, piece of equipment or terminal device  
43 meets the design requirements indicated on the drawings and in the specifications.

44  
45 Verify that provisions are being made to accomplish the specified testing, adjusting and balancing work. If  
46 problems are found, handle as specified in Part 3 under Deficiencies.

47  
48 **QUALITY ASSURANCE**

49  
50 **Qualifications**

51 An independent Firm specializing in the Testing and Balancing of HVAC systems for a minimum of 3 years.  
52 A Firm not engaged in the commerce of furnishing or providing equipment or material generally related to  
53 HVAC work other than that specifically related to installing Testing and Balancing components necessary  
54 for work in this section such as, but not limited to sheaves, pulleys, and balancing dampers.

55  
56 A certified member of AABC or certified by NEBB or TABB in the specific area of work performed.  
57 Maintain certification for the entire duration of the project..

58  
59 **SUBMITTALS**

60 See also Related Work in this section.

61  
62 Submit testing, adjusting and balancing reports bearing the seal and signature of the NEBB, AABC or TABB  
63 Certified Test and Balance Supervisor. The reports certify that the systems have been tested, adjusted and  
64 balanced in accordance with the referenced standards; are an accurate representation of how the systems have

1 been installed and are operating; and are an accurate record of all final quantities measured to establish normal  
2 operating values of the systems.

3  
4 Format: Cover page identifying project name, project number and descriptive title of contents. Divide the  
5 contents of the report into the below listed divisions:

- 6
- 7 \* General Information
- 8 \* Summary
- 9 \* Air Systems
- 10 \* Hydronic Systems

11  
12 Contents: Provide the following minimum information, forms and data:

13  
14 **General Information:** Inside cover sheet identifying Test and Balance Agency, Contractor, Architect,  
15 Engineer, Project Name and Project Number. Include addresses, contact names and telephone numbers. Also  
16 include a certification sheet containing the seal and signature of the Test and Balance Supervisor.

17  
18 **Summary:** Provide summary sheet describing mechanical system deficiencies. Describe objectionable noise  
19 or drafts found during testing, adjusting and balancing. Provide recommendations for correcting  
20 unsatisfactory performances and indicate whether modifications required are within the scope of the contract,  
21 are design related or installation related. List instrumentation used during testing, adjusting and balancing  
22 procedures.

23  
24 The remainder of the report to contain the appropriate standard NEBB, AABC, or TABB forms for each  
25 respective item and system. Fill out forms completely. Where information cannot be obtained or is not  
26 applicable indicate same.

## 27 28 **PART 2 - PRODUCTS**

### 29 30 **INSTRUMENTATION**

31 Provide all required instrumentation to obtain proper measurements. Application of instruments and  
32 accuracy of instruments and measurements to be in accordance with the requirements of NEBB, AABC, or  
33 TABB Standards and instrument manufacturer's specifications.

34  
35 All instruments used for measurements shall be accurate, and calibration histories for each instrument to be  
36 available for examination upon request. Calibration and maintenance of all instruments to be in accordance  
37 with the requirements of NEBB, AABC, or TABB Standards

## 38 39 **PART 3 - EXECUTION**

### 40 41 **PRELIMINARY PROCEDURES**

42 Review preconstruction meeting report, applicable construction bulletins, applicable change orders and  
43 approved shop drawings of equipment, outlets/inlets and temperature controls.

44  
45 Check dampers and valves for correct positioning, equipment for proper rotation and belt tension,  
46 temperature controls for completion of installation and hydronic systems for proper charge and purging of  
47 air.

48 Identify deficiencies preventing completion of testing, adjusting and balancing procedures. Do not proceed  
49 until systems are fully operational with all components necessary for complete testing, adjusting and  
50 balancing. Installing Contractors are required to provide personnel to check and verify system completion,  
51 readiness for balancing and assist Balancing Agency in providing specified system performance.

### 52 53 **PERFORMING TESTING, ADJUSTING AND BALANCING**

54 Perform testing, adjusting and balancing procedures on each system identified, in accordance with the  
55 detailed procedures outlined in the referenced standards except as may be modified below.

56  
57 In areas containing ceilings, remove ceiling tile to accomplish balancing work; replace tile when work is  
58 complete and provide new tile for any tile that are damaged by this procedure

1 Cut insulation, ductwork and piping for installation of test probes to the minimum extent necessary for  
2 adequate performance of procedures. Patch using materials identical to those removed, maintaining vapor  
3 barrier integrity and pressure rating of systems.  
4  
5 Adjust register, grille and diffuser vanes and accessories to achieve proper air distribution patterns and  
6 uniform space temperatures free from objectionable noise and drafts within the capabilities of the installed  
7 system.  
8  
9 Final air system measurements to be within the following range of specified cfm:  
10 Fans 0% to +10%  
11 Supply grilles, registers, diffusers 0% to +10%  
12 Return/exhaust grilles, registers 0% to -10%  
13  
14 Final water system measurements must be within the following range of specified gpm:  
15 Heating flow rates 0% to -10%  
16  
17 Contact the temperature control contractor for assistance in operation and adjustment of controls during  
18 testing, adjusting and balancing procedures. Cycle controls and verify proper operation and setpoints.  
19 Include in report description of temperature control operation and any deficiencies found.  
20  
21 Permanently mark equipment settings, including damper and valve positions, control settings, and similar  
22 devices allowing settings to be restored. Set and lock memory stops.  
23  
24 Leave systems in proper working order, replacing belt guards, closing access doors and electrical boxes, and  
25 restoring temperature controls to normal operating settings.

26  
27 **DEFICIENCIES**

28 Division 23 00 00 contractor to correct any installation deficiencies found by the test and balance agency that  
29 were specified and/or shown on the Contract Documents to be performed as part of that division of work.  
30 Test and balance agency will notify the Owner's Project Representative of these items and instructions will  
31 be issued to the Division 23 00 00 contractor for correction of the deficient work. All corrective work to be  
32 done at no cost to Dane County. Retest mechanical systems, equipment, and devices once corrective work is  
33 complete as specified.  
34

35  
36 END OF SECTION  
37  
38  
39  
40  
41  
42  
43  
44  
45

**Page Intentionally Left Blank**



1  
2  
3  
4  
5  
6  
7  
8  
9  
10  
11  
12  
13  
14  
15  
16  
17  
18  
19  
20  
21  
22  
23  
24  
25  
26  
27  
28  
29  
30  
31  
32  
33  
34  
35  
36  
37  
38  
39  
40  
41  
42  
43  
44  
45  
46  
47  
48  
49  
50  
51  
52  
53  
54  
55  
56  
57  
58  
59  
60  
61  
62  
63  
64  
65  
66

**SECTION 23 07 00**  
**HVAC INSULATION**

**PART 1 - GENERAL**

**SCOPE**

This section includes insulation specifications for heating, ventilating and air conditioning piping, ductwork and equipment.

**RELATED WORK**

Section 23 05 00 - Common Work Results for HVAC  
Section 23 21 13 - Hydronic Piping  
Section 23 05 29 - Hangers and Supports for HVAC Piping and Equipment  
Section 23 31 00 - HVAC Ducts  
Section 23 33 00 - Air Duct Accessories

**REFERENCE**

Applicable provisions of Division 01, General Requirements govern work under this section.

**REFERENCE STANDARDS**

ASTM C165 Test Method for Compressive Properties of Thermal Insulations  
ASTM C177 Heat Flux and Thermal Transmission Properties  
ASTM C302 Density of Preformed Pipe Insulation  
ASTM C355 Test Methods for Test for Water Vapor Transmission of Thick Materials  
ASTM C518 Heat Flux and Thermal Transmission Properties  
ASTM C547 Mineral Fiber Preformed Pipe Insulation  
ASTM C921 Properties of Jacketing Materials for Thermal Insulation  
ASTM D5590 Test Method for Determining the Resistance of Coatings to Fungal Defacement  
ASTM E84 Surface Burning Characteristics of Building Materials  
ASTM E814 Standard Test Method for Fire Tests of Penetration Firestop Systems  
MICA National Commercial & Industrial Insulation Standards  
NFPA 225 Surface Burning Characteristics of Building Materials  
UL 723 Surface Burning Characteristics of Building Materials

**QUALITY ASSURANCE**

Refer to Division 01, General Requirements, Equals and Substitutions

Insulation systems shall be applied by experienced contractors.

**DESCRIPTION**

Furnish and install all insulating materials and accessories as specified or as required for a complete installation. The following types of insulation are specified in this section:

- \* Pipe Insulation
- \* Duct Insulation

Install all insulation in accordance with the latest edition of MICA (Midwest Insulation Contractors Association) Standard and manufacturer's installation instructions. Exceptions to these standards will only be accepted where specifically modified in these specifications.

**SHOP DRAWINGS**

Refer to Division 01, General Requirements, Submittals.

Submit a schedule of all insulating materials to be used on the project, including adhesives, fastening methods, fitting materials along with material safety data sheets and intended use of each material. Include manufacturer's technical data sheets indicating density, thermal characteristics, jacket type, and manufacturer's installation instructions.

**OPERATION AND MAINTENANCE DATA**

All operations and maintenance data shall comply with the submission and content requirements specified under section GENERAL REQUIREMENTS.

**ENVIRONMENTAL REQUIREMENTS**

Do not store insulation materials on grade or where they are at risk of becoming wet. Do not install insulation products that have been exposed to water.

1  
2  
3  
4  
5  
6  
7  
8  
9  
10  
11  
12  
13  
14  
15  
16  
17  
18  
19  
20  
21  
22  
23  
24  
25  
26  
27  
28  
29  
30  
31  
32  
33  
34  
35  
36  
37  
38  
39  
40  
41  
42  
43  
44  
45  
46  
47  
48  
49  
50  
51  
52  
53  
54  
55  
56  
57  
58  
59  
60  
61  
62  
63  
64  
65  
66

**PART 2 - PRODUCTS**

**MATERIALS**

Manufacturers: CertainTeed, Manson, Childers, Dow, Extol, Fibrex, Halstead, Foster, Imcoa, Johns Manville, Knauf, Owens-Corning, VentureTape or approved equal.

Use composite insulation systems (insulation, jackets, sealants, mastics, and adhesives) that have a flame spread rating of 25 or less and smoke developed rating of 50 or less, with the following exceptions:

Pipe insulation which is not located in an air plenum may have a flame spread rating not over 25 and a smoke developed rating no higher than 450 when tested in accordance with UL 723 and ASTM E84.

**INSULATION TYPES**

Insulating materials shall be fire retardant, moisture and mildew resistant, and vermin proof. Insulation shall be suitable to receive jackets, adhesives and coatings as indicated.

**FLEXIBLE FIBERGLASS INSULATION:**

Minimum nominal density of 0.75 lbs. per cu. ft., and thermal conductivity of not more than 0.30 at 75 degrees F, rated for service to 250 degrees F.

**RIGID FIBERGLASS INSULATION:**

Minimum nominal density of 3 lbs. per cu. ft., and thermal conductivity of not more than 0.23 at 75 degrees F, 0.25 at 125 degrees F, 0.27 at 150 degrees F, 0.29 at 200 degrees F, 0.32 at 250 degrees F, minimum compressive strength of 25 PSF at 10% deformation, rated for service to 450 degrees F.

**ADHESIVES, MASTIC, SEALANTS, AND REINFORCING MATERIALS**

Products shall be compatible with surfaces and materials on which they are applied, and shall be suitable for use at operating temperatures of systems to which they are applied.

**FIBERGLASS INSULATION ADHESIVE:**

Must comply with ASTM C916, Type II: Foster 85-60, Childers CP-127, Duro Dyne SSG.

**VAPOR RETARDING MASTIC:**

Below ambient equipment/piping insulation, mastic water vapor permeance shall be less than 0.03 perms at 45 mils dry film thickness per ASTM E 96: Foster 30-65 Vapor Fas, Childers CP-34, Vimasco 749.

**JACKETS**

**PVC FITTING COVERS AND JACKETS (PFJ):**

White PVC film, gloss finish one side, semi-gloss other side, FS LP-535D, Composition A, Type II, Grade GU. Jacket thickness to be minimum .02" indoors/.03" outdoors for piping 12" and smaller, .03" indoors/.04" outdoors for piping 15" and larger.

**ALL SERVICE JACKETS (ASJ):**

Heavy duty, fire retardant material with white kraft reinforced foil vapor retarding jacket, factory applied to insulation with a self-sealing pressure sensitive adhesive lap, maximum permeance of .02 perms and minimum beach puncture resistance of 50 units.

**FOIL SCRIM ALL SERVICE JACKETS (FSJ):**

Glass fiber reinforced foil kraft laminate, factory applied to insulation. Maximum permeance of .02 perms and minimum beach puncture resistance of 25 units.

**INSULATION INSERTS AND PIPE SHIELDS**

Manufacturers: B-Line, Pipe Shields, Value Engineered Products.

Construct inserts with calcium silicate or polyisocyanurate (service temperatures below 300 degrees F only), minimum 140 psi compressive strength. Piping 12" and larger, supplement with high density 600 psi structural calcium silicate insert. Provide galvanized steel shield. Insert and shield to be minimum 180 degree coverage on bottom supported piping and full 360 degree coverage on clamped piping. On roller mounted piping and piping designed to slide on support, provide additional load distribution steel plate.

**ACCESSORIES**

All products shall be compatible with surfaces and materials on which they are applied, and be suitable for use at operating temperatures of the systems to which they are applied.

- 1 Adhesives, sealants, and protective finishes shall be as recommended by insulation manufacturer for  
2 applications specified.  
3  
4 Insulation bands to be 3/4 inch wide, constructed of aluminum or stainless steel. Minimum thickness to be  
5 0.015 inch for aluminum and 0.010 inch for stainless steel.  
6  
7 Tack fasteners to be stainless steel ring grooved shank tacks.  
8  
9 Staples to be clinch style.  
10  
11 Insulating cement to be ANSI/ASTM C195, hydraulic setting mineral wool.  
12  
13 Finishing cement to be ASTM C449.  
14  
15 Fibrous glass or canvas fabric reinforcing used with lagging adhesive shall have a minimum untreated weight  
16 of 6 oz./sq. yd.  
17  
18 Joint sealants and metal jacketing sealants to be non-shrinking and permanently flexible.  
19  
20 Vapor retarding coatings to have maximum applied water vapor permeance of 0.03 perms or less at 45 ,ils  
21 dry as tested by ASTM E96.  
22  
23 Fungicidal water base duct liner coating (Foster 40-20 or equal) to be compatible with vapor retarding  
24 coating. This product must be EPA registered to be used inside HVAC ducts. Coating must comply with  
25 ASTM D 5590 with 0 growth rating.  
26

### 27 **PART 3 - EXECUTION**

#### 28 **EXAMINATION**

29 Verify that all piping, equipment, and ductwork are tested and approved prior to installing insulation. Do not  
30 insulate systems until testing and inspection procedures are completed.  
31  
32

#### 33 **INSTALLATION**

34 All materials shall be installed in strict accordance with manufacturer's recommendations, building codes,  
35 and industry standards.  
36

37 Locate insulation and cover seams in the least visible location. All surface finishes shall be extended in such  
38 a manner as to protect all raw edges, ends and surfaces of insulation.  
39

40 Provide neatly beveled and coated terminations at all nameplates, uninsulated fittings, or at other locations  
41 where insulation terminates.  
42

43 Use full length material (as delivered from manufacturer) wherever possible. Scrap piecing of insulation or  
44 pieces cut undersize and stretched to fit will not be accepted.  
45

46 All pipe and duct insulation shall be continuous through walls, Vapor retarding jacket shall be maintained  
47 continuous through all penetrations.  
48

49 Provide a continuous unbroken moisture vapor retarding jacket on insulation applied to systems noted below.  
50 Attachments to cold surfaces shall be insulated and vapor sealed to prevent condensation.  
51

52 Provide a complete vapor retarding jacket for insulation on the following systems:

- 53 \* Insulated Duct
- 54 \* Equipment, ductwork or piping with a surface temperature below 65 degrees F
- 55

#### 56 **PROTECTIVE JACKET INSTALLATION**

##### 57 **PVC FITTING COVERS AND JACKETS (PFJ):**

58 Lap seams and joints a minimum of 2 inches and continuously seal PVC with welding solvent recommended  
59 by jacket manufacturer. Lap slip joint ends 4" without fasteners where required to absorb expansion and  
60 contraction. For sections where vapor retarding jacket is not required and jacket requires routine removal,  
61 tack fasteners may be used. Secure PVC fitting covers with tack fasteners. For systems requiring a vapor  
62 retarding jacket, apply a 1-1/2" band of mastic over ends, throat, seams and penetrations.  
63  
64

##### 65 **ALL SERVICE JACKETS (ASJ) and FOIL SCRIM ALL SERVICE JACKETS (FSJ):**

66 Install according to manufacturer's recommendations using factory supplied lap seals and butt strip seals.

1  
2 **PIPING, VALVE, AND FITTING INSULATION**

3 **GENERAL:**

4 Install insulation with butt joints and longitudinal seams closed tightly. Provide minimum 2” lap on jacket  
5 seams and 2” tape on butt joints, firmly cemented with lap adhesive unless otherwise noted. Additionally  
6 secure with staples along seams and butt joints.

7  
8 Where insulated piping is installed on hangers and supports, the insulation shall be installed continuous  
9 through the hangers and supports. High density inserts shall be provided as required to prevent the weight of  
10 the piping from crushing the insulation. Pipe shields are required at all support locations. The insulation shall  
11 not be notched or cut to accommodate the supporting channels.

12  
13 Provide insulation inserts and pipe shields at all hanger and support locations. Inserts may be omitted on  
14 3/4” and smaller copper piping provided 12” long 22 gauge pipe shields are used.

15  
16 **FITTINGS AND VALVES:**

17 Fittings, valves, unions, flanges, couplings and specialties may be insulated with factory molded or built up  
18 insulation of the same thickness as adjoining insulation. Where the ambient temperature exceeds 150 degrees  
19 F, cover insulation with fabric reinforcing and mastic. Where the ambient temperatures do not exceed 150  
20 degrees, furnish and install PVC fitting covers.

21  
22 **PIPE INSULATION SCHEDULE:**

23 Provide insulation on new and existing remodeled piping as indicated in the following schedule:

SERVICE	INSULATION	JACKET	INSULATION THICKNESS BY PIPE SIZE				
			< 1”	1” to < 1-1/2”	1-1/2” to < 4”	4” to < 8”	8” and Larger
Heating Hot Water	Rigid Fiberglass	ASJ	1.5”	1.5”	2”	2”	2”

24  
25 The following piping and fittings are not to be insulated:

- 26 \* Hot water piping inside radiation, convector, or cabinet heater enclosures
- 27 \* Piping unions for systems not requiring a vapor retarding Jacket

28  
29 **DUCT INSULATION**

30 **GENERAL:**

31 Secure flexible duct insulation on sides and bottom of ductwork over 24” wide and all rigid duct insulation  
32 with weld pins. Space fasteners 18” on center or less as required to prevent sagging.

33  
34 Stop and point insulation around access doors and damper operators to allow operation without disturbing  
35 insulation or jacket material.

36  
37 Where rigid board or flexible insulation is specified, install high density inserts to prevent the weight of the  
38 ductwork from crushing the insulation.

39  
40 **DUCT INSULATION SCHEDULE:**

41 Provide duct insulation on new and existing remodeled ductwork in the following schedule:

SERVICE	INSULATION TYPE	JACKET	THICKNESS
Exposed supply ducts*	Rigid Fiberglass	FSJ	2”
Concealed supply ducts	Flexible Fiberglass	FSJ	1-1/2”
Exhaust and relief ducts downstream of motorized backdraft dampers	Rigid Fiberglass	FSJ	2”

42  
43  
44 \* Exposed supply branch ducts located in the space they are serving do not require insulation. Exposed  
45 supply main ducts running through spaces they serve shall be insulated as exposed supply ducts scheduled  
46 above.

47  
48  
49 **END OF SECTION**  
50

1  
2  
3  
4  
5  
6  
7  
8  
9  
10  
11  
12  
13  
14  
15  
16  
17  
18  
19  
20  
21  
22  
23  
24  
25  
26  
27  
28  
29  
30  
31  
32  
33  
34  
35  
36  
37  
38  
39  
40  
41  
42  
43  
44  
45  
46  
47  
48  
49  
50  
51  
52  
53  
54  
55  
56  
57  
58  
59  
60  
61  
62  
63  
64

**SECTION 23 09 14**  
**HVAC CONTROL**

**PART 1 - GENERAL**

**SCOPE**

This sections includes electric control system specifications for HVAC

**RELATED WORK**

Section 23 05 93 - Testing, Adjusting, and Balancing for HVAC - Coordination

Section 23 09 93 - Sequence of Operation for HVAC Controls

Division 23 - HVAC - Equipment provided to be controlled or monitored

**REFERENCE**

Applicable provisions of Division 01, General Requirements govern work under this section.

**QUALITY ASSURANCE**

Approved Vendors/Installing Contractors:

CBRE/ESI 3410 Gateway Road, Brookfield, WI 53045 1-800-522-0372,

Modahl & Associates, 721 Christensen Ave. Madison WI 53714 608-843-2954

**SYSTEM DESCRIPTION**

System is to use electric actuation for radiant ceiling panels and cabinet unit heaters; and interlock new exhaust fan with existing RTU occupied/unoccupied modes.

System shall be integrated with the existing system.

**SUBMITTALS**

Include the following information:

Manufacturer's data sheets indicating model number, pressure/temperature ratings, capacity, methods and materials of construction, installation instructions, and recommended maintenance. General catalog sheets showing a series of the same device is not acceptable unless the specific model is clearly marked.

Schematic flow diagrams of systems showing equipment controlled, coils, dampers, valves, and other control devices. Each control device provided under this Section shall be uniquely labeled. Duplicate labeling may be used within similar mechanical systems. Label each device with setting or adjustable range of control. Indicate all wiring, clearly, differentiating between factory and field installed wiring. Wiring should be shown in schematics that detail contact states, relay references, etc. Diagrammatic representations of devices alone are not acceptable.

Schedule of control valves indicating system in which the device is to be used, rated capacity, flow coefficient, flow required by device served, actual pressure drop at design flow, size of operator required, close-off pressure, and locations where valves are to be installed.

Provide a complete set of control Record Drawings incorporating electric controls as specified.

**DEMOLITION**

Remove all controls to equipment be removed including control devices, wiring and conduit.

Maintain devices to be reinstalled or devices to remain in existing location to be reused.

**DESIGN CRITERIA**

Size all control apparatus to properly supply and/or operate and control the apparatus served.

Provide control devices subject to corrosive environments with corrosion protection or construct them so they are suitable for use in such an environment.

Provide devices exposed to outside ambient conditions with weather protection or construct them so they are suitable for outdoor installation.

Use only UL labeled products that comply with NEMA Standards. Electrical components and installation to meet all requirements of the electrical sections (Division 26) of project specifications.

1 **OPERATION AND MAINTENANCE DATA**

2 All operations and maintenance data shall comply with the submission and content requirements specified  
3 under Division 01, General Requirements.

4  
5 In addition to the general content specified under Division 01, General Requirements supply the following  
6 additional documentation:

- 7 1. A complete set of record control drawings.  
8

9 **MATERIAL DELIVERY AND STORAGE**

10 Provide factory shipping cartons for each piece of equipment and control device. This contractor is  
11 responsible for storage of equipment and materials inside and protected from the weather.  
12  
13

14 **PART 2 - PRODUCTS**

15 **CONTROL DAMPERS**

16 Control dampers for power roof exhausters are specified to be an accessory to the fan in Section 23 34 00,  
17 Fans.  
18

19  
20 Provide independently mounted damper end switches Damper end switches shall be independent of the  
21 damper actuators and be mounted directly to the damper shaft or auxiliary shaft that is mounted to a drive  
22 blade of the damper.  
23

24 All power required for electric actuation shall be provided by this contractor.  
25

26 Provide operators with linkages and brackets for mounting on device served.  
27

28 **CONTROL VALVES**

29 Provide all control valves as shown on the plans/details and as required to perform functions specified.  
30 Spring ranges must be selected to prevent overlap of operation and simultaneous heating and cooling.  
31

32 **WATER SYSTEMS:**

33 Use equal percentage valves for two-way control valves; size for a pressure drop not less than 4 psi or more  
34 than 6 psi. Note: For low flows, the required minimum Cv size will result in lower pressure drop than 4 psi.  
35

36 **Characterized Ball Valves:**

37 Forged brass or bronze body, stainless steel shaft and ball, reinforced Teflon or PTFE ball seals, double O-  
38 ring stem seals, characterized disk, maximum of ANSI Class IV (0.01%) leakage, suitable for use on water  
39 systems at 150 psig and 212° F. Minimum size for ball valves shall be 0.4 Cv.  
40

41 Acceptable manufacturers: Belimo  
42

43 **ELECTRIC/ELECTRONIC SPACE TEMPERATURE SENSORS**

44 **SENSORS:**

45 Stainless Steel Flush-Mount Thermistor and RTD Sensors to provide room temperature sensing for  
46 terminal heating unit control.  
47  
48

49 **CONTROL MODULES:**

50 Penn System 450 Series, Model C450CCN-3 digital electronic control for control of heating terminal units.  
51

52 **POWER SUPPLIES**

53 Provide all required power supplies for transducers, sensors, transmitters and relays. All low voltage  
54 transformers shall have a resettable secondary circuit breaker and be listed as class 2 power supplies.  
55  
56

57 **PART 3 - EXECUTION**

58 **INSTALLATION**

59 Install system with trained mechanics and electricians employed by the control equipment manufacturer or  
60 an authorized representative of the manufacturer. Where installing contractor is an authorized representative  
61 of the control manufacturer, such authorization shall have been in effect for a period of no less than three  
62 years.  
63  
64

1 Install all control equipment, accessories and wiring, in a neat and workmanlike manner. All control devices  
2 must be installed in accessible locations. This contractor shall verify that all control devices furnished under  
3 this Section are functional and operating the mechanical equipment as specified in Section 23 09 93.  
4

5 Provide all electrical relays and wiring, line and low voltage, for control systems, devices and components.  
6 Install all high voltage and low voltage wiring (includes low voltage cable) in metal conduit, Electrical Non-  
7 metallic Tubing (ENT), or Electrical Metallic Tubing (EMT), as scheduled below and hereafter referred to  
8 generically as conduit except above accessible ceilings as noted below. See Wire and Air Piping Conduit  
9 Installation Schedule below for specific conduit or tubing to be used. All raceways, enclosures, fittings and  
10 associated supports shall be provided and installed according to the requirements set forth in Division 16,  
11 NFPA 90 (NEC) and Chapter SPS 316 of the Wisconsin Administrative Code. All conduits shall be routed  
12 parallel and/or perpendicular to walls and adjacent piping. Raceways shall be located to maintain headroom  
13 and working clearance around equipment and devices that require inspection and service.  
14

15 In general, support all raceways from the building structure. No component of a raceway system shall be  
16 secured to corrugated metal roof deck. Do not impose on the installations of other trades. Securing conduit,  
17 rods, straps, hangers, etc. to suspended ceiling components, electrical raceways, plumbing piping, fire  
18 protection sprinkler piping, HVAC piping or ductwork, or their associated support systems, will not be  
19 accepted.  
20

21 Conduit shall be a minimum of 1/2 " for low voltage control provided the pipe fill does not exceed 40%.

22  
23 Minimum low voltage wiring gauge to be 18 AWG for outputs and 20 AWG for inputs. All low voltage  
24 wiring to be stranded.  
25

26 Low voltage wiring can be run without conduit above accessible lay-in tile ceilings. All wiring in mechanical  
27 rooms, above inaccessible hard ceilings, exterior locations, and in any exposed areas, and in all other  
28 locations shall be in conduit. Wire for wall sensors shall be run in conduit. Wiring for radiation valves shall  
29 be run in conduit where routed through walls.  
30

31 Where wiring is installed free-air, installation shall comply with the following:

- 32 • Wiring shall run at right angles and be kept clear of other trades work.
- 33 • Wiring shall be supported utilizing "J" or "Bridal-type" steel mounting rings anchored to ceiling  
34 concrete, piping supports, walls above ceiling or structural steel beams. Mounting rings shall be of  
35 open design (not a closed loop) to allow additional wire to be strung without being threaded through  
36 the ring. For mounting rings that do not completely surround the wire, attach the wire to the mounting  
37 ring with a strap.
- 38 • At HVAC terminal units only, where the wiring serves a specific device; e.g. controller, actuator,  
39 transmitter, etc. associated with the unit, the j-hooks or Bridal rings required to support the wiring, may  
40 be secured to the rods or straps that support the ductwork or piping that serves the unit. Wall  
41 penetrations shall be sleeved.
- 42 • Supports shall be spaced at a maximum 4-foot interval unless limited by building construction. If  
43 wiring "sag" at mid-span exceeds 6-inches; another support shall be used.
- 44 • Wall penetrations shall be sleeved and fire stopped as specified.
- 45 • Wiring shall not be supported from existing cabling, existing tubing, plumbing or steam piping,  
46 ductwork, any component of a suspended ceiling, or electrical or communications conduit.  
47

#### 48 **WIRE CONDUIT AND TUBING INSTALLATION SCHEDULE**

49 The following conduit schedule shall apply to wire in conduit where conduit is specified wiring.  
50

51 Conduit other than that specified below for specific applications shall not be used.  
52

53 Concealed Dry Interior Locations: Rigid steel conduit. Intermediate metal conduit. Electrical metallic tubing.  
54

55 Exposed Dry Interior Locations: Rigid steel conduit. Intermediate metal conduit. Electrical metallic tubing.  
56

#### 57 **CONTROL DAMPERS**

58 Damper end switches, where required, shall be independently mounted to the damper drive shaft or auxiliary  
59 shaft attached to a damper drive blade. End switches shall be adjusted to prove the damper the position  
60 opposite the fail position of the damper actuator unless the control sequence requires a different position to  
61 be proven to accomplish the specified control sequence.  
62

63 Coordinate installation with the sheet metal installer to obtain smooth duct transitions where damper size is  
64 different than duct size. Blank off plates will not be accepted.  
65

#### 66 **CONTROL VALVES**

1 All temperature control valves furnished by the control manufacturer are to be installed by the Mechanical  
2 Contractor under the coordinating control and supervision of the Control Contractor in locations shown on  
3 plans or where required to provide specified sequence of control.  
4

5 **ROOM THERMOSTATS AND TEMPERATURE SENSORS**

6 Check and verify location of thermostats and other exposed control sensors with plans and room details  
7 before installation. Locate room thermostats and sensors with occupant adjustment 48 inches above floor.  
8 Align with light switches. For drywall installations, thermostat mounting shall use a back-box attached to a  
9 wall stud, drywall anchors are not acceptable.  
10

11 **OWNER TRAINING**

12 Contractor to provide factory authorized representative and/or field personnel knowledgeable with the  
13 operations, maintenance and troubleshooting of the system and/or components defined within this section.  
14  
15  
16

17 **END OF SECTION**



1  
2  
3 **SECTION 23 09 93**  
4 **SEQUENCE OF OPERATION FOR HVAC CONTROLS**

5 **PART 1 - GENERAL**

6  
7 **SCOPE**

8 This section includes control sequences for HVAC equipment installed or modified as part of this project.  
9

10 **RELATED WORK**

11 Applicable provisions of Division 01, General Requirements govern work under this Section.

12  
13 Section 23 09 14 - HVAC Control

14 Section 23 05 93 - Testing, Adjusting, and Balancing for HVAC – Coordination

15 Section 23 34 00 - Fans

16 Section 23 82 00 - Heating Terminal Units  
17

18 **REFERENCE**

19 Section 23 09 14 work includes furnishing and installing all field devices, including electronic sensors for  
20 the work of this section, equipment, and all related field wiring, interlocking control wiring between  
21 equipment, sensor mounting, etc., that is covered in that section.  
22

23 **DESCRIPTION OF WORK**

24 Control sequences are hereby defined as the manner and method by which automatic controls function.  
25 Requirements for each type of operation are specified in this section.  
26

27 Operation equipment, devices and system components required for automatic control systems are specified  
28 in other Division 23 control sections of these specifications.  
29

30 All temperature, and pressure sensing, and all other control signal transportation for the control sequences  
31 shall be furnished under Section 23 09 14. All electronic, and electric input/output signals shall be extended  
32 under Section 23 09 14  
33

34 **SUBMITTALS**

35 Refer to Division 01, General Requirements, Submittals, Section 23 05 00 and Sections 23 09 24 or 23 09  
36 25, and 23 09 14 for descriptions of what should be included in the submittals.  
37

38 Shop drawings shall be provided by contractor providing equipment under Section 23 09 14. The contractor  
39 providing the 23 09 14 equipment shall provide a complete narrative of the sequence of operation for  
40 equipment that is controlled directly from that equipment. The narrative of the sequence of operation shall  
41 not be a verbatim copy of the sequences contained herein, but shall reflect the actual operation as applied by  
42 the contractor.  
43

44 **OPERATION AND MAINTENANCE DATA**

45 All operations and maintenance data shall comply with the submission and content requirements specified  
46 under section Division 01, General Requirements.  
47

48  
49 **PART 2 - PRODUCTS**

50  
51 Not applicable to this Section – reference Section 23 09 14 for product descriptions.  
52  
53

54 **PART 3 - EXECUTION**

55  
56 GENERAL:

57  
58 **SETPOINTS:**

59 All set points indicated in the control specification are to be adjustable. The set points shall be readily  
60 available to be modified in the mechanical system software system summary (either textual or graphic based)  
61 and under the same software level as hardware points. Some less used set points may be provided on a lower  
62 software level. The set points indicated herein are only specified as a calculated starting point (or initial  
63 system operation). It is expected that set point adjustments and control loop tuning shall be required to  
64 provide optimum system operation based on requirements of the building. The control contractor shall work

1 with the balancing contractor and the Owner to provide the final system set point adjustments and control  
2 loop tuning after the system is in operation and building is in use. Document all final set points on the as-  
3 built control drawings. Any questions regarding the intended operation of the HVAC equipment and control  
4 systems shall be referred to the HVAC design engineer through the appropriate construction communication  
5 process.  
6

7 **ANTI-CYCLING:**

8 When HVAC equipment or a sequence is specified to be started and stopped by a temperature set point or  
9 any other controlled variable, there shall be an adjustable differential set point that shall be set to prevent  
10 short cycling of the systems and equipment due to minor changes in the controlled variable. Temperature  
11 differential set points shall be set at 2° F and non-temperature set points shall be set at 10% of the controlled  
12 range unless otherwise specified.  
13

14 **DEADBANDS:**

15 Provide deadbands to prevent constant hunting of output signals to controlled devices. Deadbands shall be  
16 set to provide adequate control around set point as follows unless otherwise specified in the individual control  
17 sequences:  
18

19 Temperature Control:  $\pm 0.5^{\circ}$  F  
20

21 **THERMOSTATS AND SENSORS:**

22 All devices and equipment including terminal units, specified to be controlled in a control sequence by a  
23 thermostat or sensor, shall be provided with a thermostat or sensor, whether or not the device is indicated on  
24 the plans.  
25

26 **RADIANT CEILING PANELS AND CONVECTOR RADIATION (New and Existing)**

27 Refer to control notes in the Demolition Key Notes and New Work Piping Key Notes and sequence of  
28 operation on the drawings.  
29

30 **CABINET UNIT HEATER CONTROL:**

31 Reuse the existing electric space sensor to control the control valve as indicated in the sequence of operation  
32 on the drawings. Provide all required materials for the installation.  
33

34 **SINGLE DUCT VAV TERMINAL UNIT WITH REHEAT: (EXISTING VAV TERMINAL NO. 33)**

35 Existing control sequence for VAV terminal # 33 shall remain as installed in the previous project that  
36 installed the unit.  
37

38  
39 Work to be included in this project is to remove the current thermostat and associated wiring connecting the  
40 room control to the VAV terminal and reinstalling complete in the new location indicated on the drawing to  
41 provide the original control sequence for the VAV terminal.  
42

43 **EXHAUST FAN CONTROL**

44 Exhaust fans shall be controlled as follows:  
45

46 PRV-2 and PRV-3: Existing control sequence shall remain unaltered  
47

48 PRV-4: Integrate control of this new exhaust fan into the existing building automation system similar to  
49 existing exhaust fans. Refer to control sequence on drawings:  
50  
51

52  
53 **END OF SECTION**  
54  
55  
56



1  
2  
3 **PART 2 - PRODUCTS**

4 HEATING HOT WATER

5 2" and Smaller: ASTM A53, type F, standard weight (schedule 40) black steel pipe with ASTM A126/ANSI  
6 B16.4, class 125, standard weight cast iron threaded fittings.

7 Contractor may use ASTM B88 seamless, type L, hard temper copper tube with ANSI B16.22 wrought  
8 copper solder-joint fittings in lieu of steel pipe for all sizes. Mechanically formed tee fittings may be used in  
9 lieu of wrought copper solder-joint tee fittings for branch takeoff up to one-half (1/2) the diameter of the  
10 main.

11  
12 UNIONS AND FLANGES

13 2" and Smaller: ASTM A197/ANSI B16.3 malleable iron unions with brass seats. Use black malleable iron  
14 on black steel piping and galvanized malleable iron on galvanized steel piping. Use ANSI B16.18 cast copper  
15 alloy unions on copper piping. Use unions of a pressure class equal to or higher than that specified for the  
16 fittings of the respective piping service but not less than 250 psi.

17  
18  
19 **PART 3 - EXECUTION**

20  
21 ERECTION

22 Carefully inspect all pipe, fittings, valves, equipment and accessories before installation. Any items that are  
23 unsuitable, cracked or otherwise defective shall be rejected and removed from the job site immediately.  
24 Excluding minor surface rust, piping that exhibits significant oxidation or corrosion will be rejected.

25  
26 Exercise care at every stage of storage, handling, laying and erecting to prevent entry of foreign matter into  
27 piping, fittings, valves, equipment and accessories. Do not erect or install any item that is not clean.

28  
29 Remove all loose dirt, scale, oil, chips, burrs and other foreign material from the internal and external surfaces  
30 of all pipe and piping components prior to assembly, including debris associated with cutting, threading and  
31 welding.

32  
33 During fabrication and assembly, remove slag and weld spatter from internal pipe surfaces at all joints by  
34 peening, chipping and wire brushing.

35  
36 During construction, until system is fully operational, keep all openings in piping and equipment closed  
37 except when actual work is being performed on that item of the system. Use plugs, caps, blind flanges or  
38 other items designed for this purpose.

39  
40 Furnish and install all flanges, caps, bypasses, drains, valves, etc. required to facilitate flushing and draining  
41 all heating and cooling system piping.

42  
43 Install all piping parallel to building walls and ceilings and at heights which do not obstruct any portion of a  
44 window, doorway, stairway, or passageway. Where interferences develop in the field, offset or reroute piping  
45 as required to clear such interferences. In all cases, consult drawings for exact location of pipe spaces, ceiling  
46 heights, door and window openings, or other architectural details before installing piping.

47  
48 Mitered ells, notched tees, and orange peel reducers are not acceptable. On threaded piping, bushings are  
49 not acceptable.

50  
51 "Weldolets" and "Threadolets" may be used for branch takeoffs up to one-half (1/2) the diameter of the main.

52  
53 Install drains throughout the systems to permit complete drainage.

54  
55 Do not route piping through transformer vaults or above transformers, panelboards, or switchboards,  
56 including the required service space for this equipment, unless the piping is serving this equipment

57  
58 Install all valves, control valves, and piping specialties, including items furnished by others, as specified  
59 and/or detailed. Make connections to all equipment installed by others where that equipment requires the  
60 piping services indicated in this section.



1 PIPING SYSTEM LEAKAGE TEST REPORT

2  
3  
4 **Dane County, Wisconsin**  
5 **Department of Public Works**

**Date**  
**Submitted:** \_\_\_\_\_

8 **Project Name:** \_\_\_\_\_

10 **Location:** \_\_\_\_\_ **Project No:** \_\_\_\_\_

12 **Contractor:** \_\_\_\_\_

- 14  HVAC                       Refrigeration                       Controls
- 15  Power Plant                       Plumbing                       Sprinkler

16 **Test Medium:**     Air             Water             Other \_\_\_\_\_

18 **Test performed per specification section No.** \_\_\_\_\_

20 **Specified Test Duration** \_\_\_\_\_ **Hours**            **Specified Test Pressure** \_\_\_\_\_ **PSIG**

22 **System Identification:** \_\_\_\_\_

24 **Describe Location:** \_\_\_\_\_

26 \_\_\_\_\_

28 29 <b>Test Date:</b> _____	
30 31 <b>Start Test Time:</b> _____	31 32 <b>Initial Pressure:</b> _____ <b>PSIG</b>
32 33 <b>Stop Test Time:</b> _____	33 34 <b>Final Pressure:</b> _____ <b>PSIG</b>

36 **Tested By:** \_\_\_\_\_ **Witnessed By:** \_\_\_\_\_

38 **Title:** \_\_\_\_\_ **Title:** \_\_\_\_\_

40 **Signed:** \_\_\_\_\_ **Signed:** \_\_\_\_\_

42 **Date:** \_\_\_\_\_ **Date:** \_\_\_\_\_

44 **Comments:** \_\_\_\_\_

46 \_\_\_\_\_

48 END OF SECTION

1  
2  
3  
4  
5  
6  
7  
8  
9  
10  
11  
12  
13  
14  
15  
16  
17  
18  
19  
20  
21  
22  
23  
24  
25  
26  
27  
28  
29  
30  
31  
32  
33  
34  
35  
36  
37  
38  
39  
40  
41  
42  
43  
44  
45  
46  
47  
48  
49  
50  
51  
52  
53  
54  
55  
56  
57  
58  
59  
60  
61  
62  
63

**SECTION 23 31 00**  
**HVAC DUCTS**

**PART 1 - GENERAL**

**SCOPE**

This section includes specifications for all duct systems used on this project.

**RELATED WORK**

Section 23 05 93 - Testing, Adjusting, and Balancing for HVAC

Section 23 33 00 - Air Duct Accessories

Section 23 34 00 - HVAC Fans

**REFERENCE**

Applicable provisions of Division 01, General Requirements govern work under this Section.

**REFERENCE STANDARDS**

ANSI SS-EN 485-2	Aluminum and Aluminum Alloys-Sheet, Strip and Plate-Part 2: Mechanical Properties
ASTM B209	Specification for Aluminum and Aluminum-Alloy Sheet and Plate
ASTM A90	Test Method for Weight of Coating on Zinc-Coated (Galvanized) Iron or Steel Articles
ASTM A623	Standard Specification for Steel Sheet, Zinc-Coated (Galvanized) by the Hot-Dip Process
ASTM A527	Specification for General Requirements for Steel Sheet, Zinc-Coated (Galvanized) by the Hot-Dip Process, Lock-Forming Quality
ASTM 924	Standard Specification for General Requirements for Sheet Steel, Metallic-coated by the Hot-dip Method
ASTM C 1071	Specification for Fibrous Glass Duct Lining Insulation
ASTM E 84	Test Method for Surface Burning Characteristics of Building Materials
ASTM C 1338	Test Method for Determining Fungal Resistance of Insulation Materials and Facings
ASTM G 21	Standard Practice for Determining Resistance of Synthetic Polymeric Materials to Fungi
ASTM C 916	Standard Specification for Adhesives for Duct Thermal InsulationNFPA 90A Standard for the Installation of Air Conditioning and Ventilating Systems
UL 181	Standard for Safety for Factory Made Air Ducts and Air Connectors.
NAIMA	Fibrous Glass Duct Liner Standard

**QUALITY ASSURANCE**

Refer to Division 01, General Requirements, Equals and Substitutions.

**SHOP DRAWINGS**

Refer to Division 01, General Requirements, Submittals.

Include manufacturer's data and/or Contractor data for the following:

- \* Fabrication and installation drawings.
- \* Duct sealant and gasket material.
- \* Duct liner including data on thermal conductivity, air friction correction factor, and limitation on temperature and velocity.

**DESIGN CRITERIA**

Construct all ductwork to be free from vibration, chatter, objectionable pulsations and leakage under specified operating conditions.

Use material, weight, thickness, gauge, construction and installation methods as outlined in the following SMACNA publications, unless noted otherwise:

- \* HVAC Duct Construction Standards, Metal and Flexible, 3rd Edition, 2005

- 1           \*       HVAC Air Duct Leakage Test Manual, 2<sup>nd</sup> Edition, 2012
- 2           \*       HVAC Systems - Duct Design, 4th Edition, 2006
- 3           \*       Rectangular Industrial Duct Construction Standard, 2nd Edition, 2004
- 4           \*       Round Industrial Duct Construction Standards, 2<sup>nd</sup> Edition, 1999

5  
6 Use products which conform to NFPA 90A, possessing a flame spread rating of not over 25 and a smoke developed rating no higher than 50.

7  
8  
9 **DELIVERY, STORAGE AND HANDLING**

10 Promptly inspect shipments to ensure that Ductwork is undamaged and complies with the specification.

11  
12 Protect Ductwork against damage.

13  
14 Protect Ductwork by storing inside or by durable, waterproof, above ground packaging. Do not store material on grade. Protect Ductwork from dirt, dust, construction debris and foreign material. Where end caps/packaging are provided, take precautions so caps/packaging remain in place and free from damage.

15  
16  
17  
18 Offsite storage agreements do not relieve the contractor from using proper storage techniques.

19  
20 Storage and protection methods must allow inspection to verify products.

21  
22  
23 **PART 2 - PRODUCTS**

24  
25 **GENERAL**

26 All sheet metal used for construction of duct shall be 24 gauge or heavier except for round and spiral ductwork and spiral duct take-offs 12" and below may be 26 gauge where allowed in SMACNA HVAC Duct Construction Standards, Metal and Flexible, 3rd Edition, 2005.

27  
28  
29  
30 Duct sizes indicated on plans are net inside dimensions; where duct liner is specified, dimensions are net, inside of liner.

31  
32  
33 **DUCTWORK PRESSURE CLASS**

34  
35 Minimum acceptable duct pressure class, for all ductwork except transfer ductwork, is 2 inch W.G. positive or negative, depending on the application. Transfer ductwork minimum acceptable duct pressure class is 1 inch W.G. positive or negative, depending on the application. Duct system pressure classes not indicated on the drawings to be as follows:

36  
37  
38  
39

40	Supply duct downstream of VAV terminals	___1___ in. calc. S.P.	___2___ in. pressure class
41	Transfer air ducts	___1___ in. calc. S.P.	___1___ in. pressure class
42	Exhaust air ducts	___1___ in. calc. S.P.	___2___ in. pressure class
43	Return air ducts	___1___ in. calc. S.P.	___2___ in. pressure class

44  
45 **MATERIALS**

46 **GALVANIZED STEEL SHEET:**

47 Use ASTM A 653 galvanized steel sheet of lock forming quality. Galvanized coating to be 1.25 ounces per square foot, both sides of sheet, G90 in accordance with ASTM A90. Provide "Paint Grip" finish or galvaneal sheetmetal for ductwork that will be painted.

48  
49  
50  
51 **ALUMINUM SHEET:**

52 Use ANSI/ASTM B209 aluminum sheet, alloy 3003H-14, capable of double seaming without fracture.

53  
54 **LOW PRESSURE DUCTWORK (Maximum 2 inch pressure class)**

55 Fabricate and install ductwork in sizes indicated on the drawings and in accordance with SMACNA recommendations, except as modified below.

56  
57  
58 Construct so that all interior surfaces are smooth. Use slip and drive or flanged and bolted construction when fabricating rectangular ductwork. Use spiral lock seam construction when fabricating round spiral ductwork. Sheet metal screws may be used on duct hangers, transverse joints and other SMACNA approved locations if the screw does not extend more than 1/2 inch into the duct.



1 Use elbows and tees with a center line radius to width or diameter ratio of 1.5 wherever space permits. When  
2 a shorter radius must be used due to limited space, install single wall sheet metal splitter vanes in accordance  
3 with SMACNA publications, Type RE 3. Where space will not allow and the C value of the radius elbow,  
4 as given in SMACNA publications, exceeds 0.31, use rectangular elbows with turning vanes as specified in  
5 Section 23 33 00. Square throat-radius heel elbows will not be acceptable. Straight taps or bullhead tees are  
6 not acceptable.

7  
8 Where rectangular elbows are used, provide turning vanes in accordance with Section 23 33 00.

9  
10 Provide expanded take-offs or 45 degree entry fittings for branch duct connections with branch ductwork  
11 airflow velocities greater than 700 fpm. Square edge 90-degree take-off fittings or straight taps will not be  
12 accepted.

13  
14 Button punch snaplock construction will not be accepted on aluminum ductwork.

15  
16 Round ducts may be substituted for rectangular ducts if sized in accordance with ASHRAE table of  
17 equivalent rectangular and round ducts. No variation of duct configuration or sizes permitted except by  
18 written permission of the Architect/Engineer.

19  
20 Increase duct sizes gradually, not exceeding 15 degrees divergence wherever possible. Divergence upstream  
21 of equipment shall not exceed 30 degrees; convergence downstream shall not exceed 45 degrees.

### 22 **EXHAUST DUCT (Moisture laden air)**

23  
24 Moisture laden ductwork systems including restroom.

25  
26 Exhaust ducts conveying moisture laden air, other than dishwasher exhaust, to be constructed of sheet  
27 aluminum in accordance with SMACNA standards.

28  
29 Seal all joints and seams watertight

### 30 **DUCT SEALANT**

31  
32 Manufacturer: 3M 800, 3M 900, H.B. Fuller/Foster, Hardcast, Hardcast Peal & Seal, Lockformer cold  
33 sealant, Mon-Eco Industries, United Sheet Metal, or approved equal. Silicone sealants are not allowed in  
34 any type of ductwork installation.

35  
36 Install sealants in strict accordance with manufacturer's recommendations, paying special attention to  
37 temperature limitations. Allow sealant to fully cure before pressure testing of ductwork, or before startup of  
38 air handling systems.

### 39 **GASKETS**

40  
41 **2 INCH PRESSURE CLASS AND LOWER:**

42 Soft neoprene or butyl gaskets in combination with duct sealant for flanged joints.

## 43 **PART 3 - EXECUTION**

### 44 **INSTALLATION**

45  
46 Verify dimensions at the site, making field measurements and drawings necessary for fabrication and  
47 erection. Check plans showing work of other trades and consult with Architect in the event of any  
48 interference.

49  
50 Make allowances for beams, pipes or other obstructions in building construction and for work of other  
51 contractors. Transform, divide or offset ducts as required, in accordance with SMACNA HVAC Duct  
52 Construction Standards, Figure 4-7, except do not reduce duct to less than six inches in any dimension and  
53 do not exceed an 8:1 aspect ratio. Where it is necessary to take pipes or similar obstructions through ducts,  
54 construct easement as indicated in SMACNA HVAC Duct Construction Standards, Figure 4-8, Fig. E. In  
55 all cases, seal to prevent air leakage. Pipes or similar obstructions may not pass through high pressure or  
56 fume exhaust ductwork.

57  
58 Test openings for test and balance work will be provided under Section 23 05 93.

1 Provide frames constructed of angles or channels for coils, filters, dampers or other devices installed in duct  
2 systems, and make all connections to such equipment including equipment furnished by others. Secure  
3 frames with gaskets and screws or nut, bolts and washers.  
4

5 Where two different metal ducts meet, the joint shall be installed in such a manner that metal ducts do not  
6 contact each other by using proper seal or compound.  
7

8 Install all motor operated dampers and connect to or install all equipment furnished by others. Blank off all  
9 unused portions of louvers, as indicated on the drawings, with 1-1/2 inch board insulation with galvanized  
10 sheet metal backing on both sides.  
11

12 Do not install ductwork through dedicated electrical rooms or spaces unless the ductwork is serving this room  
13 or space.  
14

15 Locate ducts with sufficient space around equipment to allow normal operating and maintenance activities.  
16

17 Provide adequate access to ductwork for cleaning purposes.  
18

19 Provide temporary capping of ductwork openings to prevent entry of dirt, dust and foreign material.  
20

21 Protect diffusers, registers and grilles with plastic wrap or some other approved form of protection to  
22 maintain dirt and dust free and to prevent entry of dirt, dust and foreign material into the Ductwork.  
23

24 Install prefabricated grease ductwork assemblies in accordance with manufacturer requirements and NFPA  
25 96.  
26

27 During construction provide temporary closures of metal or taped polyethylene on open ductwork to prevent  
28 construction dust from entering ductwork system.  
29

### 30 **DUCTWORK SUPPORT**

31 Support ductwork in accordance with SMACNA HVAC Duct Construction Standards, Figure 5-5, except  
32 supporting ductwork with secure wire method is not allowed.  
33

34 Support with 3/32 inch, 7 x 7, stainless steel air-craft cable, with matching serrated spring loaded wedge  
35 mechanism fasteners rated for actual load. Steel cable hanging systems will be allowed on round ductwork  
36 under 12 inches diameter if installed utilizing two fasteners with two cable loops. Comply with the  
37 manufacturer's installation instructions.  
38

### 39 **CLEANING**

40 Remove all dirt and foreign matter from the entire duct system and clean diffusers, registers, grilles and the  
41 inside of air-handling units before operating fans.  
42

43 Clean duct systems with high power vacuum machines where systems have been used for temporary heat,  
44 air-conditioning, or ventilation purposes during construction. Protect equipment that may be harmed by  
45 excessive dirt with filters, or bypass during cleaning.  
46

### 47 **LEAKAGE TEST**

48 Leakage test for ductwork downstream of air terminal devices may be omitted but will not relieve the  
49 contractor from duct sealing requirements.  
50

51 The Owner and Engineer shall inspect duct for construction and sealing. Based on observation of the  
52 construction and sealing the system shall be accepted of the contractor shall be directed to make repairs until  
53 the ductwork is acceptable.  
54

55  
56 **END OF SECTION**  
57  
58  
59  
60  
61

1  
2  
3  
4  
5  
6  
7  
8  
9  
10  
11  
12  
13  
14  
15  
16  
17  
18  
19  
20  
21  
22  
23  
24  
25  
26  
27  
28  
29  
30  
31  
32  
33  
34  
35  
36  
37  
38  
39  
40  
41  
42  
43  
44

**SECTION 23 33 00**  
**AIR DUCT ACCESSORIES**

**PART 1 - GENERAL**

57  
58  
59  
60  
61  
62  
63  
64  
65  
66

**SCOPE**

This sections includes accessories used in the installation of duct systems.

**RELATED WORK**

Section 23 05 29 – Hanger and Supports for HVAC Piping and Equipment

Section 23 31 00 – HVAC Ducts

**REFERENCE**

Applicable provisions of Division 1 govern work under this Section.

**REFERENCE STANDARDS**

NFPA 90A Standard for Installation of Air Conditioning and Ventilating Systems

SMACNA HVAC Duct Construction Standards - Metal and Flexible, 2nd Edition, 1995

UL 214

UL 555 (6<sup>th</sup> edition) Standard for Fire Dampers and Ceiling Dampers

UL 555S (4<sup>th</sup> edition) Leakage Rated Dampers for Use in Smoke Control Systems

**QUALITY ASSURANCE**

Refer to Division 01, General Requirements, Equals and Substitutions

**SHOP DRAWINGS**

Refer to Division 01, General Requirements, Submittals.

Submit for all accessories and include dimensions, capacities, ratings, installation instructions, and appropriate identification.

Include certified test data on dynamic insertion loss, self-noise power levels, and aerodynamic performance of sound attenuators.

Submit manufacturer's color charts where finish color is specified to be selected by the Architect/Engineer.

**OPERATION AND MAINTENANCE DATA**

All operations and maintenance data shall comply with the submission and content requirements specified under section GENERAL REQUIREMENTS.

**PART 2 - PRODUCTS**

**MANUAL VOLUME DAMPERS**

Manufacturers: Ruskin, Vent Products, Air Balance, or approved equal.

Dampers must be constructed in accordance with SMACNA Fig. 2-12, Fig. 2-13, and notes relating to these figures, except as modified below.

Reinforce all blades to prevent vibration, flutter, or other noise. Construct dampers in multiple sections with mullions where width is over 48 inches. Use rivets or tack welds to secure individual components; sheet metal screws will not be accepted. Provide operators with locking devices and damper position indicators for each damper; use an elevated platform on insulated ducts. Provide end bearings or bushings for all volume damper rods penetrating ductwork constructed to a 3" w.c. pressure class or above.

**TURNING VANES**

Manufacturers: Aero Dyne, Anemostat, Barber-Colman, Hart & Cooley, or approved equal.

Construct turning vanes and runners for square elbows in accordance with SMACNA Fig. 2-3 and Fig. 2-4 except use only airfoil type vanes. Construct turning vanes for short radius elbows and elbows where one dimension changes in the turn in accordance with SMACNA Fig. 2-5 and Fig. 2-6.

**FLEXIBLE DUCT**

Manufacturers: Anco Products, Clevaflex, Thermaflex, Flexmaster or approved equal.

1 Factory fabricated , UL 181 listed as a class 1 duct, and having a flame spread of 25 or less and a smoke  
2 developed rating of 50 or under in accordance with NFPA 90A.

3  
4 Suitable for pressures and temperatures involved but not less than a 180°F service temperature and ±2 inch  
5 pressure class, depending on the application.

6  
7 Duct to be composed of polyester film, aluminum laminate or woven and coated fiberglass fabric bonded  
8 permanently to corrosion resistant coated steel wire helix. Two-ply, laminated, and corrugated aluminum  
9 construction may also be used.

10  
11 Where duct is specified to be insulated, provide a minimum 1 inch fiberglass insulation blanket with  
12 maximum thermal conductance of 0.23 K (75 degrees F.) and vapor barrier jacket of polyethylene or  
13 metalized reinforced film laminate. Maximum perm rating of vapor barrier jacket to be 0.1 perm.

#### 14 **DUCT LINING**

15  
16 Manufacturer: Manville, Owens-Corning, Knauf, or approved equal.

17  
18 1 inch thick, flexible, mat faced insulation made from inorganic glass fibers bonded with a thermosetting  
19 resin with thermal conductivity of .25 Btu inch / hour sq.ft. deg F.

20  
21 Meet erosion testing per UL 181 or ASTM C 1071 for 5000 fpm maximum air velocity. ASTM C 411  
22 maximum operating temperature rating of 250 deg F. ASTM E84 flame spread less than 25 and smoke  
23 developed less than 50.

24  
25 Meet requirements of ASTM C 1338 and ASTM G21 for fungi resistance.

26  
27 Install liner using adhesive conforming to ASTM C 916.

#### 28 **FLASHINGS**

29  
30 Flashing and counterflashing for roof curbs will be provided by others.

31  
32 Flashing and curbs for duct and pipe penetrations of roof assemblies to be in accordance with details.

### 33 **PART 3 - EXECUTION**

#### 34 **MANUAL VOLUME DAMPERS**

35  
36 Install manual volume dampers in each branch duct and for each grille, register, or diffuser as far away from  
37 the outlet as possible while still maintaining accessibility to the damper. Install so there is no flutter or  
38 vibration of the damper blade(s).

#### 39 **TURNING VANES**

40  
41 Install turning vanes in all rectangular, mitered elbows in accordance with SMACNA standards and/or  
42 manufacturer's recommendations.

43  
44 Install double wall, airfoil, 2 inch radius vanes in ducts with vane runner length 18" or greater and air velocity  
45 less than 2000 fpm. Install double wall, airfoil, 4-1/2 inch radius vanes in ducts with vane runner length 18"  
46 or greater and air velocity 2000 fpm or greater.

47  
48 If duct size changes in a mitered elbow, use single wall type vanes with a trailing edge extension. If duct  
49 size changes in a radius elbow or if short radius elbows must be used, install sheetmetal turning vanes in  
50 accordance with SMACNA Figure 2-5 and Figure 2-6.

#### 51 **FLEXIBLE DUCT**

52  
53 Flexible duct may only be used for final connections of air inlets and outlets at diffuser, register, and grille  
54 locations which are concealed. Where flexible duct is used, it shall be the minimum length required to make  
55 the final connections, but no greater than 5 feet in length, and have no more than one (1) 90 degree bend.

56  
57 Secure inner jacket of flexible duct in place with stainless steel metal band clamp. Secure insulation vapor  
58 barrier jacket in place with steel or nylon draw band. Sheetmetal screws and/or duct tape will not be accepted.

1 Individual sections of flexible ductwork shall be of one piece construction. Splicing of short sections will  
2 not be accepted.  
3  
4 Flexible ductwork used as transfer duct shall be sized for a maximum velocity of 350 fpm.  
5  
6 Penetration of any partition, wall, or floor with flexible duct will not be accepted.  
7  
8 **DUCT LINING**  
9 Apply lining to the following ductwork:  
10 • Transfer air ducts as detailed and noted on drawings  
11  
12 Install liner in compliance with the latest edition of NAIMA's Fibrous Glass Duct Liner Standard. Locate  
13 longitudinal joints at the corners of duct only. Cut and fit to assure lapped, compressed joints. Coat all  
14 transverse and longitudinal joints and edges with adhesive. Provide metal nosing on leading edge where  
15 lined duct is preceded by unlined duct. Adhere liner to duct with full coverage area of adhesive. Additionally  
16 secure liner to duct using mechanical fasteners spaced as recommended by the liner manufacturer without  
17 compressing liner more than 1/8" with the fasteners.  
18  
19 **FLASHINGS**  
20 Flashing for roof curbs, will be installed by others.  
21  
22 **DUCT FLEXIBLE CONNECTIONS**  
23 Install at all duct connections to rotating or vibrating equipment, including air handling units (unless unit is  
24 internally isolated), fans, or other motorized equipment in accordance with SMACNA Figure 2-19. Install  
25 thrust restraints to prevent excess strain on duct flexible connections at fan inlets and outlets; see Related  
26 Work.  
27  
28  
29  
30

END OF SECTION

**Page Intentionally Left Blank**

1  
2  
3 **SECTION 23 34 00**  
4 **HVAC FANS**

5 **PART 1 - GENERAL**

6  
7 **SCOPE**

8 This section includes specifications for fans that are not an integral part of a manufactured device.  
9

10 **RELATED WORK**

11 Section 23 05 29 - Hangers and Supports for HVAC Piping and Equipment  
12 Section 23 05 13 - Common Motor Requirements for HVAC Equipment  
13

14 **REFERENCE**

15 Applicable provisions of Division 01, General Requirements govern work under this Section.  
16

17 **REFERENCE STANDARDS**

18 AMCA 203 AMCA Fan Application Manual - Troubleshooting  
19 AMCA 210 Laboratory Method of Testing Fans for Rating  
20 AMCA 300 Reverberant Room Method for Sound Testing of Fans  
21 NFPA 90A Standard for the Installation of Air Conditioning and Ventilating Systems  
22 NFPA 96 Standard for Ventilation Control and Fire Protection of Commercial Cooking Operations  
23 UL 762 Power Roof Ventilators For Restaurant Exhaust Appliances  
24

25 **QUALITY ASSURANCE**

26 Refer to Division 01, General Requirements, Equals and Substitutions.  
27

28 **SHOP DRAWINGS**

29 Refer to Division 01, General Requirements, Submittals.  
30

31 Include dimensions, capacities, fan curves, materials of construction, ratings, weights, motors and drives,  
32 sound power levels, appropriate identification and vibration isolation for all equipment. Sound power levels  
33 to be based on tests performed in accordance with AMCA Standard 300.  
34

35 Submit color selection charts for equipment where applicable.  
36

37 Fan curves shall indicate the relationship of CFM to static or total pressure for various fan speeds. Brake  
38 horsepower, recommended selection range, and limits of operation are to also be indicated on the curves.  
39 Indicate operating point on the fan curves at design air quantity and indicate the manufacturer's recommended  
40 drive loss factor for the specific application. Tabular fan performance data is not acceptable.  
41

42 For variable air volume application, include data which indicates the effect of capacity control devices, such  
43 as inlet vanes, on performance.  
44

45 **OPERATION AND MAINTENANCE DATA**

46 All operations and maintenance data shall comply with the submission and content requirements specified  
47 under section GENERAL REQUIREMENTS.  
48

49 **DESIGN CRITERIA**

50 Tested and certify all fans in accordance with the applicable AMCA test code.  
51

52 Each fan and motor combination shall be capable of delivering 110% of air quantity scheduled at scheduled  
53 static pressure. The motor furnished with the fan shall not operate into the motor service factor when  
54 operating under these conditions.  
55

56 Consider drive efficiency in motor selection according to manufacturer's published recommendation or  
57 according to AMCA Publication 203, Appendix L.  
58

59 Where inlet and outlet ductwork at any fan is changed from that shown on the drawings, provide any motor,  
60 drive and/or wiring changes required due to increased static pressure or baffling necessary to prevent uneven  
61 airflow or improve mixing.  
62

63 All internal insulation and other components exposed to the airstream are to meet the flame spread and smoke  
64 ratings contained in NFPA 90A.  
65

1 All roof mounted equipment to be provided with curbs or equipment stands in accordance with specification  
2 in Section 23 05 29.

## 3 4 5 **PART 2 - PRODUCTS**

### 6 7 **GENERAL**

8 Use fan size, class, type, arrangement, and capacity as scheduled.

9  
10 Furnish complete with motors, wheels, drive assemblies, bearings, vibration isolation devices, and  
11 accessories required for specified performance and proper operation. All single phase motors to have  
12 inherent thermal overload protection.

13  
14 Provide variable pitch sheaves for drives 3 hp and smaller, fixed pitch sheaves for drives 5 hp and larger.  
15 Design all drives for 150% of motor rating.

16  
17 Use OSHA approved belt guards that totally enclose the entire drive. Construct guards of expanded metal to  
18 allow for ventilation; provide tachometer openings at shaft locations.

19  
20 Statically and dynamically balance all fans so they operate without objectionable noise or vibration.

21 Use AMCA Type A spark resistant construction for all fans handling flammable or explosive vapors.

### 22 23 24 **POWER ROOF EXHAUST FANS**

25 Manufacturers: Carnes, Greenheck, Penn, Jenn-Air, Cook, ACME or approved equal.

26  
27 Provide upblast or downblast units, as scheduled, with aluminum housing, non-overloading type centrifugal  
28 wheel, inlet cone, factory mounted and wired motor and disconnect switch, and bird screen.

29  
30 Provide disconnect switches and thermal overload protection for units with three phase motors as scheduled.

31  
32 Provide motor operated backdraft damper and damper actuator as scheduled.

33  
34 Provide roof curb. Curb to be minimum 18 inches high.

35  
36 Provide accessories as scheduled.

## 37 38 39 **PART 3 - EXECUTION**

### 40 41 **INSTALLATION**

42 Install as shown on the drawings, as detailed, and according to manufacturer's installation instructions

### 43 44 45 **POWER ROOF EXHAUSTERS**

46 Coordinate installation with General Contractor for installation of curbs.

47  
48  
49 **END OF SECTION**



1  
2  
3 **SECTION 23 37 13**  
4 **DIFFUSERS, REGISTERS & GRILLES**

5  
6 **PART 1 - GENERAL**  
7

8 **SCOPE**

9 This section includes specifications for air terminal equipment.  
10

11 **PART 3 - EXECUTION**

12 Installation  
13

14 **RELATED WORK**

15 Section 23 31 00 - HVAC Ducts

16 Section 23 33 00 - Air Duct Accessories

17 Section 23 05 93 - Testing, Adjusting and Balancing for HVAC  
18

19 **REFERENCE**

20 Applicable provisions of Division 01, General Requirements govern work under this section.  
21

22 **REFERENCE STANDARDS**

23 NFPA 90A - Installation of Air Conditioning and Ventilation Systems.

24 UL 181 - Factory-Made Air Ducts and Connectors.

25 ARI-ADC Standard 880  
26

27 **QUALITY ASSURANCE**

28 Refer to Division 01, General Requirements, Equals and Substitutions.  
29

30 **SUBMITTALS**

31 Refer to Division 01, General Requirements, Submittals.  
32

33  
34 Furnish submittal information including, but not limited to, the following:

35 Manufacturer's name and model number

36 Identification as referenced in the documents

37 Capacities/ratings

38 Materials of construction

39 Sound ratings

40 Dimensions

41 Finish

42 Color selection charts where applicable

43 Manufacturer's installation instructions  
44

45 **DESIGN CRITERIA**

46 All performance data shall be based on tests conducted in accordance with Air Diffusion Council (ADC) Test  
47 Code 1062 GRD 84.  
48

49 **PART 2 – PRODUCTS**  
50

51 **ROUND CEILING DIFFUSERS**

52 Manufacturers: Carnes, Krueger, Titus, Metal-Aire, and E.H. Price  
53

54 Spun aluminum or steel with uniform 360° discharge pattern.  
55

56 Adjustable inner cones surrounded by a ceiling plate collar designed to reduce ceiling smudges.

1  
2 Diffusers as shown on drawings and/or as scheduled.  
3  
4 White, baked enamel finish or powder coat finish, unless otherwise indicated.  
5  
6 **SQUARE CEILING DIFFUSERS – Plaque**  
7 Manufacturers: Carnes, Krueger, Titus, Metal-Aire, and E.H. Price  
8  
9 Aluminum or Steel unless otherwise indicated, louvered face furnished with frame type appropriate to  
10 installation.  
11  
12 Directional blow pattern as shown on the drawings and/or as scheduled.  
13  
14 One-piece removable square face plaque with one-piece backpan.  
15  
16 White, baked enamel finish or powder coat finish, unless otherwise indicated.  
17  
18 **SIDE-WALL, CEILING OR DUCT MOUNTED REGISTERS AND GRILLES**  
19 Manufacturers: Carnes, Krueger, Titus, Metal-Aire, and E.H. Price  
20  
21 Aluminum or Steel as scheduled unless otherwise indicated, with frame type appropriate to installation.  
22  
23 Double deflection type blade supply registers and supply grilles allow deflection adjustment in all direction.  
24  
25 Opposed blade volume control damper supply registers, operable from face when scheduled.  
26  
27 Fixed blade (0 degree or 45 degree) core return and exhaust registers and grilles.  
28  
29 Opposed blade volume control damper return registers, operable from face when scheduled.  
30  
31 Register and grille sizes as shown on drawings and/or as scheduled.  
32  
33 White, baked enamel finish or powder coat finish, unless otherwise indicated.  
34  
35 Screw holes on surface counter sunk to accept recessed type screws.  
36

### 37 38 **PART 3 - EXECUTION**

#### 39 40 **INSTALLATION**

41  
42 Install grilles, registers and diffusers as shown on drawings and according to manufacturer's instructions.  
43  
44 Furnish diffusers with equalizing grids where it is not possible to maintain minimum 2 duct diameter straight  
45 duct into diffuser. Equalizing grids shall consist of individually adjustable vanes designed for equalizing  
46 airflow into diffuser neck and providing directional control of airflow.  
47  
48 Unless otherwise indicated, size ductwork drops to diffusers or grilles to match unit collar size.  
49  
50 Seal connections between ductwork drops and diffusers/grilles airtight.  
51  
52 Where diffusers, registers and grilles cannot be installed to avoid seeing inside duct, paint inside of duct with  
53 flat black paint to reduce visibility.  
54

55 **END OF SECTION**

1  
2  
3  
4  
5  
6  
7  
8  
9  
10  
11  
12  
13  
14  
15  
16  
17  
18  
19  
20  
21  
22  
23  
24  
25  
26  
27  
28  
29  
30  
31  
32  
33  
34  
35  
36  
37  
38  
39  
40  
41  
42  
43  
44  
45  
46  
47  
48  
49  
50  
51  
52  
53  
54  
55  
56  
57  
58  
59  
60  
61  
62

**SECTION 23 82 00**  
**HEATING TERMINAL UNITS**

**PART 1 - GENERAL**

**SCOPE**

This section includes specification for heating terminal equipment using water as the source.

**RELATED WORK**

Section 23 05 23 - General-Duty Valves for HVAC Piping

**REFERENCE**

Applicable provisions of Division 01, General Requirements govern work under this Section.

**REFERENCE STANDARDS**

ARI 210 Standard for Unitary Air-Conditioning Equipment

ARI 410 Standard for Forced-Circulation Air-Cooling and Air-Heating Coils

CS 140

**QUALITY ASSURANCE**

Refer to Division 01, General Requirements, Equals and Substitutions

**SHOP DRAWINGS**

Refer to Division 01, General Requirements, Submittals.

Include dimensions, capacities, materials of construction, ratings, weights, wiring diagrams, and appropriate identification for all equipment in this section. Include color selection chart where applicable.

**OPERATION AND MAINTENANCE DATA**

All operations and maintenance data shall comply with the submission and content requirements specified under section GENERAL REQUIREMENTS.

**PART 2 - PRODUCTS**

**CABINET UNIT HEATERS**

Manufacturers: Trane, Sterling, Airtherm, Rittling, Vulcan or approved equal.

Construct vertical unit casings with 16 gauge steel front panels and minimum 18 gauge steel end and side panels. Horizontal units located in concealed spaces or mounted in ceiling to have minimum 18 gauge front, end, and side panels.

Furnish exposed cabinets in a baked enamel finish in one of the manufacturer's standard colors, selected by the Architect.

Furnish ceiling mounted units with a hinged front panel to allow access to all internal components.

Construct heating elements of copper tubes with aluminum fins, tested at 200 psig.

Use centrifugal type fans, statically and dynamically balanced to operate without objectionable noise and vibration.

Motors to be 120 volt, single phase, permanently lubricated, with thermal overload protection and disconnect switch at unit.

Furnish each unit with filter rack and 1" panel filters.

**RADIANT CEILING PANELS**

Manufacturers: Sterling, Rittling, Vulcan or approved equal.

1 **GENERAL DESCRIPTION:**

2 The panels are fabricated from either 18 gauge aluminum sheet with a heating coil is mechanically  
3 fastened. Thermal contact between the coil and panel is to maintained by an aluminum heat saddle  
4 fastened with welded aluminum or steel studs. The coil is clipped to the heat saddle using cadmium plated  
5 steel clips where heat transfer paste is used at the interface between the aluminum heat saddle and both the  
6 face of the panel and the tubing.

7  
8 **DIMENSIONS AND WEIGHT**

9 Modular panels to be provided in the sizes scheduled:

10  
11 The working weight for the aluminum panels is approximately 1.5 lb/ft<sup>2</sup>

12  
13 **CONSTRUCTION**

14 Pipework: Each panel has its own serpentine pipe coil of 5/8" O.D. tubing.

15  
16 Panels: 0.040" aluminum with standard square edges or tegular edge as scheduled of detailed.

17  
18 Paint finish: Standard finish is off-white.

19  
20 Contact strips: Aluminum heat saddle bolted to the back of the panel using steel or aluminum studs  
21 welded to the panel.

22  
23 **INSULATION:**

24 Minimum of 1" thick foil back batt insulation.  
25

26  
27 **PART 3 - EXECUTION**

28  
29 **INSTALLATION**

30  
31 Install units in accordance with manufacturer's installation instructions.

32  
33 Install branch water or steam/condensate piping to each unit with a minimum of three elbows to allow for  
34 expansion and contraction of the piping system.

35  
36 Coordinate location of units with other trades to assure correct recess size for recessed units.

37  
38 After installation, provide protective covers to prevent accumulation of dirt on units during balance of  
39 construction.

40  
41 **CABINET UNIT HEATERS**

42 Mount units in locations indicated on the drawings and as detailed. Install a drain valve on the coil side of  
43 the shutoff valves for each hot water cabinet heater.

44  
45 **RADIANT CEILING PANELS**

46 Install at locations indicated on drawings.

47  
48 Pipe as detailed. Where more than one panel is controlled by one control valve pipe hot water each panel  
49 supply from the valve and after passing through the panel the return shall be connected and piped to the  
50 building return.

51  
52 Provide specified insulation on the top of the panel.

53  
54 Coordinate the installation with the General Contractor.

55  
56 **END OF SECTION**

SECTION 26 05 00

GENERAL ELECTRICAL REQUIREMENTS

PART 1 - GENERAL

1.01 SCOPE

- A. Conditions of the Contract and portions of Division One of this Project Manual apply to this Section as though repeated herein.

1.02 GENERAL PROVISIONS

- A. In general, the work includes: Electrical work and the kindred materials and operations as indicated on the drawings and as specified in the following articles of:

Section 26 05 00	General Electrical Requirements
Section 26 09 23	Occupancy Sensor
Section 26 20 00	Basic Materials and Methods
Section 26 51 13	Lighting
Section 27 10 00	Telecommunications Distribution System
Section 28 31 00	Fire Alarm System

- B. Job Information: Obtain at building including:
  - 1. Conditions affecting this Section of the Work.
  - 2. Accessibility
  - 3. Storage space.

1.03 GENERAL REQUIREMENTS

- A. This Section of the Specifications applies to all electrical work. The General Conditions, Supplementary Conditions, Summary of the Work, Instructions to Bidders and all Sections of the Conditions of the Contract form a part of these specifications and the Contractor shall consult them in detail. Electrical work indicated in other Sections of the Specifications to be done by the Electrical Contractor shall be included in the Work of this Section.

1.04 DEFINITIONS

- A. Certain terms used herein; on the drawings; and in the contract documents, shall be defined as follows:
- B. Provide: Furnish and install complete and ready for service.
- C. Exposed: Exposed to view in any room, hallway, passageway, or outside.
- D. Approval: The approval of the Architect in writing or by signed rubber stamp applied to drawings, illustrations, etc.

1.05 INTENT OF DRAWINGS AND SPECIFICATIONS

- A. These specifications and attendant drawings are intended to cover a complete installation of systems. The omission of expressed reference to any item of labor or material necessary for the proper execution of the work in accordance with present practice of the trade shall not relieve the Contractor from providing such additional labor and materials.

1.06 DRAWINGS

- A. The Electrical drawings do not attempt to show the complete details of building construction which affect the electrical installation. The Contractor shall refer to the architectural, civil, structural and mechanical drawings for additional details which affect the proper installation of this work. The Contractor is cautioned that diagrams showing electrical connections and/or circuiting are diagrammatic only and must not be used for obtaining lineal runs of wire to conduit. Wiring diagrams

1 do not necessarily show the exact physical arrangement of the equipment.

2 1.07 MATERIAL AND EQUIPMENT

- 3 A. All material and equipment shall be new and of the quality used for the purpose in good commercial  
4 practice and shall be standard product of reputable manufacturers. Each major component of  
5 equipment shall have the manufacturer's name, catalog number, and capacity or rating on a nameplate,  
6 securely affixed on the equipment in a conspicuous place.

7 1.08 SUBSTITUTION AND APPROVAL OF MATERIAL

- 8 A. See Instructions to Bidders.  
9 B. Such requests shall be accompanied by three copies of all necessary illustrations, cuts, drawings and  
10 descriptions of material proposed for substitution and shall fully describe all points in which it differs  
11 from the articles specified. Two copies will be retained by the Architect and one copy returned to the  
12 Contractor with approval or revisions indicated thereon.

13 1.09 DAMAGE TO OTHER WORK

- 14 A. The Electrical Contractor will be held rigidly responsible for all damages to the work of his own or  
15 any other trade resulting from the execution of his work. It shall be the Contractor's responsibility to  
16 adequately protect his work at all times. All damages resulting from his operations shall be repaired  
17 or the damaged portions replaced by the party originally performing the work, (to the entire  
18 satisfaction of the Architect), and all cost thereof shall be borne by the Contractor responsible for the  
19 damage.

20 1.10 COOPERATION WITH OTHER TRADES

- 21 A. This Contractor shall completely cooperate with all other trades in the matter of planning and  
22 executing of the work. Every reasonable effort shall be made to prevent conflict and interferences as  
23 to space requirements, dimensions, locations, openings, sleeving or other matters which tend to delay  
24 or obstruct the work of any trade.

25 1.11 NEGLIGENCE

- 26 A. Should the Contractor fail to provide materials, templates, etc., or other necessary information causing  
27 delay or expense to another party, he shall pay the actual amount of the damages to the party who  
28 sustained the loss.

29 1.12 FIELD CHANGES

- 30 A. Should any change in drawings or specifications be required to comply with local regulations and/or  
31 field conditions, the Contractor shall refer same to Architect for approval before any work which  
32 deviates from the original requirements of the drawings and specifications is started. In the event of  
33 disagreements as to the necessity of such changes, the decision of the Architect shall be final.

34 1.13 CUTTING AND PATCHING IN NEW CONSTRUCTION

- 35 A. As necessary and with approval to permit the installation of conduit or any part of the work under this  
36 branch. Any cost caused by defective or ill-timed work shall be by the party responsible therefor.  
37 Patching of holes, openings, etc. resulting from the work of this branch shall be furnished by this  
38 contractor.  
39 B. See Division 1 for additional requirements.

40 1.14 COMPLETION DATES

- 41 A. This Contractor shall be in a position to meet all completion dates established by the Architect and  
42 shall furnish all labor of all classes required to meet such schedules and completion dates.

43 1.15 STANDARDS, CODES AND PERMITS

- 44 A. All work shall be installed in accordance with National, State and Local electrical codes, laws,

- 1 ordinances and regulations. Comply with all applicable OSHA regulations.
- 2 B. All materials shall have a U.L. label where a U.L. standards and/or test exists.
- 3 C. Prepare and submit to all authorities having jurisdiction, for their approval, all applications and  
4 working drawings required by them.
- 5 D. Secure and pay for all permits and licenses required.

6 1.16 CLEAN-UP

- 7 A. This Contractor shall at all times keep the premises free from excessive accumulation of waste  
8 material or rubbish resulting from his work, including tools, scaffolding and surplus materials, and he  
9 shall leave his work broom clean or its equivalent.
- 10 B. In case of dispute, Architect may order the removal of such rubbish and charge the cost to the  
11 responsible contractor as determined by the Architect. At the time of final clean-up all fixtures and  
12 equipment shall be thoroughly cleaned and left in proper condition for their intended use.

13 1.17 TESTS

- 14 A. The Contractor shall provide all instrumentation, labor and conduct all tests required by the Architect.  
15 All tests shall be made before any circuit or item of equipment is permanently energized. Circuits  
16 shall be phased out and loads shall be distributed as evenly as possible on all phases. All phase  
17 conductors shall be entirely free from grounds and short circuits. All instrumentation and personnel  
18 required for testing shall be provided by the Contractor and all tests shall be conducted in the presence  
19 of the Architect or his authorized representative.
- 20 B. System Tests:
- 21 1. The following tests are required prior to energization of the electrical system:
- 22 a. Secondary feeders shall have an insulation resistance test utilizing a megger applying a  
23 test potential of 500 volts DC minimum.
- 24 b. Establish secondary phase to ground voltages.
- 25 c. Establish proper phase relationship and motor rotation.
- 26 2. The following tests are required under normal load condition:
- 27 a. Record secondary phase to phase and phase to ground voltages and phase currents at all  
28 major equipment, apparatus, and on all secondary feeders. Voltage readings shall be  
29 taken at line side terminals of distribution centers and panelboards.
- 30 b. Confirm proper phase relationship and motor rotation.
- 31 c. Confirm load balance at distribution centers and panels. Rebalance load if necessary  
32 such that the minimum unbalance between phases shall not exceed 7-1/2%.
- 33 d. Confirm operation of all electrically operated apparatus, such as circuit breakers,  
34 transfer switches, etc., by exercising same under load.
- 35 e. Record all settings and calibrations of circuit breakers, transfer switches, transformers,  
36 meters, timing devices, etc.
- 37 C. Records:
- 38 1. All test data obtained by the E.C. or manufacturer/supplier shall be recorded and filed with the  
39 maintenance manual as part of permanent job records. Test data shall include identification of  
40 instruments employed (field test only), condition of test (time, date, weather, etc.), parameters  
41 of test, personnel conducting test, and any pertinent information or conditions noted during the  
42 test.

43 1.18 SHOP DRAWINGS

- 44 A. Submit to Engineer for review, copies of manufacturer's shop drawings and/or equipment brochure  
45 depicting:
- 46 1. Lighting Fixtures

- 1           2.     Panelboards
- 2           3.     Occupancy Sensors
- 3           4.     Telecommunications Equipment and Cabling
- 4           5.     Wiring Devices
- 5           6.     Fire Alarm System
- 6           7.     Other materials at the request of the Engineer
- 7           B.     See Section 01300.
- 8           C.     Shop drawings shall bear the Contractor's stamp indicating approval.
- 9           D.     Any equipment fabrication prior to shop drawing review shall be at the Contractor's risk.

10       1.19   WORKMANSHIP

- 11           A.     The installation of all work shall be made so that its several component parts will function as a
- 12                 workable system complete with all accessories necessary for its operation, and shall be left with all
- 13                 equipment properly adjusted and in working order. The work shall be executed in conformity with
- 14                 the best accepted standard practice of the trade so as to contribute to efficiency and appearance. It
- 15                 shall also be executed so that the installation will conform and adjust itself to the building structure,
- 16                 its equipment and its usage.

17       1.20   DRAWINGS OF OTHER TRADES

- 18           A.     The Contractor shall consult the drawings of the work for the various other trades; field layouts of the
- 19                 parties performing the work of the other trades; their shop drawings, and he shall be governed
- 20                 accordingly in laying out his work.
- 21           B.     Specifically examine shop drawings to confirm voltage, current characteristics, and other wiring
- 22                 requirements for utilization equipment. Bring any discrepancies to the attention of the A/E.

23       1.21   FIELD MEASUREMENTS

- 24           A.     The Contractor shall take all field measurements necessary for his work and shall assume the full
- 25                 responsibility for their accuracy.

26       1.22   STRUCTURAL INTERFERENCES

- 27           A.     Should any structural interferences prevent the installation of the outlets, running of conduits, etc., at
- 28                 points shown on drawings, the necessary minor deviation therefrom, as determined by the Architect,
- 29                 may be permitted. Minor changes in the position of the outlets or equipment if decided upon before
- 30                 any work has been done by the Contractor shall be made without additional charge.

31       1.23   EXAMINATION OF PLANS, SPECIFICATIONS AND SITE

- 32           A.     Before submitting a bid, the Contractor shall visit the site and familiarize himself with all features of
- 33                 the building and site which may affect the execution of his work. No extra payment will be allowed
- 34                 for the failure to obtain this information. If in the opinion of the Contractor there are omissions or
- 35                 errors in the plans or specifications, the Contractor shall clarify these points with the Architect before
- 36                 submitting his bid. In lieu of written clarification by addendum, resolve all conflicts in favor of the
- 37                 greater quantity or better quality.

38       1.24   GUARANTEE

- 39           A.     The Contractor shall unconditionally guarantee his work and all components thereof, excluding
- 40                 lamps, for a period of one year from the date of his final payment. He shall remedy any defects in
- 41                 workmanship and repair or replace any faulty equipment which shall appear within the guarantee
- 42                 period to the entire satisfaction of the Architect at no additional charge.

43       1.25   TEMPORARY WIRING AND SERVICE

- 44           A.     Provide temporary service from existing service. Temporary service shall support construction



- 1 activities.
- 2 B. All contractors shall provide and maintain their own extension cords and additional lamps as required  
3 to perform his work properly. Contractors requiring temporary connections to 3 phase power service  
4 and single phase feeders for other than lighting and small fractional horsepower motorized tools shall  
5 make arrangement with the Electrical Contractor. Contractors requiring lighting outside of the  
6 building shall make their own arrangements with the Electrical Contractor and pay all costs for  
7 installation, maintenance and removal. Contractors requiring electrical equipment over one HP,  
8 including welders, hoists, heaters and coolers shall make their own arrangements for such service  
9 beyond the main switch and shall pay all costs thereof.
- 10 C. No permanent electrical equipment or wiring shall be used for temporary connections, unless  
11 authorized by this Section, upon signed order and with approval by the Architect in behalf of the  
12 Owner. Such approvals shall not shorten guarantee period.
- 13 D. Electrical energy to be paid for by owner.

14 1.26 ELECTRICAL SERVICE

- 15 A. The service is existing and provides 208Y/120 volts, three phase, four wire.

16 1.27 BRANCH CIRCUIT WIRING

- 17 A. See plans for general arrangement of circuits, conduit runs, and ratings of branch circuits and special  
18 circuits.
- 19 B. Provide everything necessary to comply with the general scheme shown, including all types of  
20 control.
- 21 C. Circuit numbers as shown on plans are for contractor to plan his wiring and for estimating purposes.  
22 These numbers are not necessarily consecutive numbers of the panelboard breakers. Balanced load on  
23 bus is to be the determining factor in arrangement of circuits. Balance loading to within 7 1/2%.
- 24 D. Minimum size of lighting system branch circuit conductors to be #12 AWG.
- 25 E. Conductors terminating at wired outlets shall extend at least eight (8) inches beyond outlet box  
26 conduit fitting.
- 27 F. 120-volt circuit home runs greater than 50 feet in length shall have #10 AWG minimum size between  
28 panel and first receptacle or fixture outlet.
- 29 G. The use of single-phase, multi-wire branch circuits with a common neutral is not permitted. All  
30 branch circuits will be furnished and installed with an individual accompanying neutral, sized the  
31 same as the phase conductors

32 1.28 MOTOR WIRING

- 33 A. Unless otherwise indicated on the drawings or elsewhere in these specifications, all motors shall be  
34 furnished by others.
- 35 B. Motors shall be set in place by others and the associated motor starters and controllers shall be turned  
36 over to this Contractor for erection and line voltage power wiring.
- 37 C. Any contractor supplying starters and controllers that are not part of this contract shall index same and  
38 provide this Contractor with instructions as to proper location in sufficient time to permit the  
39 installation of a concealed raceway system.
- 40 D. Where this Contractor is required to provide control wiring, the Contractor supplying the controllers  
41 shall provide all necessary and required wiring diagrams for proper installation.
- 42 E. Low voltage (less than 115 volts) control wiring shall be by others, unless noted elsewhere in the  
43 specifications except that this Contractor shall extend circuit to associated transformers, wire and  
44 connect to same.
- 45 F. This Contractor shall examine the plans and specifications of other sections and shall include in his  
46 bid all control wiring, as referenced to be performed by Section 16001.

- 1 G. Required disconnect switches furnished by other sections shall be installed by Section 16001.  
2 Furthermore, this Contractor shall provide all disconnect switches required by code that are not  
3 furnished by other sections.

4 1.29 SPECIAL OUTLETS

- 5 A. General: Furnish and install outlets, wiring and receptacles accordingly, at locations required by  
6 equipment serviced or otherwise as directed. Extend wiring to outlets on equipment and make final  
7 connection.

8 1.30 IDENTIFICATION

9 A. General:

- 10 1. Materials and equipment installed under this Section shall be clearly identified as listed below.  
11 2. Locate identification conspicuously.  
12 3. Terminology to be approved by Architect.  
13 4. See plans for any additional items to be identified.  
14 5. Loads such as motors shall be described by function rather than by the system of arbitrary  
15 number as shown on electrical plans.  
16 6. Use abbreviations sparingly.

17 B. Laminated Bakelite Plates: Engraved plastic nameplate shall be securely screwed or riveted to the  
18 following equipment. Size 1" x 4" with 3/8" high letters; unless space available dictates differently.

- 19 1. Each panelboard, contactor, time switch, starter or disconnect switch. Locate on inside cover  
20 of panels.  
21 2. Each feeder at all accessible locations.  
22 3. Each end of empty conduit runs to indicate the intended use of the conduit and the location of  
23 opposite end. Use room numbers that are permanently assigned.

24 C. Typewritten Directory: Each panelboard both new and existing shall be provided with a typewritten  
25 directory attached to the inside of panel door and covered with clear plastic indicating load served and  
26 rooms served by each protective device in the respective panel. Spares and spaces shall be clearly  
27 identified for existing panels, trace existing circuits to confirm use.

28 D. Switch Station:

- 29 1. All key switches shall be engraved indicating controlled item.  
30 2. All remote switches shall be engraved indicating controlled item.

31 E. Conductor Identification:

- 32 1. Identify each conductor at each wiring device, connector or splice point with permanently  
33 attached wrap-around adhesive markers as manufactured by Brady Co. or 3M.  
34 2. This identification shall include branch circuit number, control circuit, or any other appropriate  
35 number or lettering that will expedite future tracing and trouble shooting.

36 1.31 LOCATIONS OF OUTLETS AND WIRING DEVICES

37 A. Outlets:

- 38 1. Locations of outlets and electrical equipment on the drawings are approximate only. Unless  
39 otherwise indicated on the drawings or established in the specifications, the exact locations of  
40 electrical outlets shall be established in the field by directive from the Architect. Generally,  
41 outlets shall be located as required for proper installation of equipment served and otherwise  
42 locations shall be established by construction or code requirements and such as to be  
43 coordinated with equipment of other trades.  
44 2. This Section shall consult with the Architect and refer to all details, sections, elevations and  
45 equipment plans and the plans of other trades for exact location.  
46 3. The Architect reserves the right to make reasonable changes in the location of outlets,  
47 apparatus or equipment up to the time of roughing in. Such changes as directed shall be made

1 by the Contractor without additional compensation.

2 4. Dimensions taken by scale shall not be used to establish rough-in locations.

3 B. Wiring Devices:

4 1. The approximate location of wiring devices are indicated on the drawings; the specific location  
5 shall be determined in accordance with "Location of Outlets" of these specifications and as  
6 follows.

7 2. This Section is referred to equipment plans, equipment shop drawings, elevation drawings and  
8 other detail or dimensional drawings, and he shall consult with the Architect before installation  
9 of proceeding with any work dependent upon this information.

10 3. Generally, wiring devices shall be located as follows:

11 a. Wall receptacles shall generally be centered 15" above the finished floor and 6" above  
12 surface of built-in counters and tables where same abuts wall and 4" above  
13 backsplashes if counters are so equipped.

14 b. Special purpose receptacles shall be located as required by equipment served.

15 c. Switches shall be centered 48" above finished floor on latch side of door opening with  
16 edge of plate not more than 12" from door frame, except as noted on the drawings.

17 d. In hazardous areas, the location of wiring devices shall be established by Code  
18 requirements which shall take precedence over conflicting information on the drawings  
19 or included herein.

20 1.32 TELEPHONE SYSTEM

21 A. Refer to the electrical specification section 27 10 00 – Telecommunication Distribution System for  
22 detailed information on the telephone system.

23 B. Dane County is currently using a VOIP (voice over internet protocol) telephone system so all  
24 telephone cabling will be using same cabling used for data.

25 C. Telephone instruments, switching equipment, wiring, terminal blocks, and other accessories shall be  
26 furnished and installed by the Owner (Dane County)

27 D. This Contractor shall supply all required conduit, sleeves, and service fittings for the telephone  
28 system.

29 E. All conduits shall be complete with fish wire by this Contractor, and all telephone outlets shall be fed  
30 by a minimum 1" conduit.

31 F. All telephone boxes shall be two gang boxes with one gang plaster cover.

32 G. Verify all phone locations with the Architect in the field.

33 1.33 SEALING AND FIREPROOFING

34 A. Sealing and fireproofing of openings between conduit, cable tray, wireway, trough, cablebus, busduct,  
35 etc. and fire rated surfaces shall be the responsibility of the contractor whose work penetrates the  
36 opening.

37 B. Sealing and fireproofing shall use materials and methods complying with ASTM E814 requirements  
38 appropriate to the rating of the material penetrated.

39 C. Materials by Dow-Corning, 3M, Specified Technologies, Inc., and Chase-Foam are acceptable if in  
40 accordance with (B) above.

41 D. Submit manufacturer's penetration details to authority having jurisdiction. Details shall confirm  
42 method's compliance with ASTM E814.

43 E. Include copies of penetration details in Project Operation and Maintenance Manuals.

44 1.34 ALTERNATE BIDS

45 A. See Section 01030 for descriptions of alternates required.



SECTION 26 09 23

OCCUPANCY SENSOR LIGHTING CONTROL SYSTEM

PART 1 - GENERAL

1.01 SCOPE

- A. Conditions of the Contract and portions of Division One of this Project Manual apply to this Section as though repeated herein.

1.02 GENERAL PROVISIONS

- A. In general, the work includes:
  - 1. Contractor's work to include all labor, materials, tools, appliances, control hardware, sensor, wire, junction boxes and equipment necessary for and incidental to the delivery, installation and furnishing of a completely operational occupancy sensor lighting control system, as described herein.
  - 2. Contractor/Supplier shall examine all general specification provisions and drawings for related electrical work required as work under Division 26
  - 3. Contractor must submit data sheets on sensors, control units and all junction boxes and mounting accessories, including all wiring diagrams.

1.03 EQUIPMENT QUALIFICATION

- A. Products supplied shall be from a manufacturer that has been continuously involved in the manufacturing of occupancy sensors for a minimum of five (5) years.
- B. All components shall be UL listed, offer a five (5) year warranty and meet all state and local applicable codes requirements.

1.04 SYSTEM DESCRIPTION

- A. The objective of this section is to ensure the proper installation of the occupancy sensor-based lighting control system so that lighting is turned off automatically after reasonable time delay when a room or area is vacated by the last person to occupy said room or area.
- B. The occupancy sensor-based lighting control shall accommodate all conditions of space utilization and all irregular work hours and habits.
- C. Contractor shall warrant all equipment furnished in accordance to this specification to be undamaged, free of defects in materials and workmanship, and in conformance with the specifications. The supplier's obligation shall include repair or replacement, and testing without charge to the owner, all or in parts of equipment which are found to be damaged, defective or non-conforming and returned to the supplier. The warranty shall commence upon the owner's acceptance of the project. Warranty on labor shall be for a minimum period of one (1) year.

1.05 SUBMITTALS

- A. Manufacturer shall substantiate conformance to this specification by supplying the necessary documents, performance data, and wiring diagrams. Any deviations to this specification must be clearly stated by letter and submitted.
- B. Submit a lighting plan clearly marked by manufacturer showing proper product, location, and orientation of each sensor.
- C. Submit any interconnection diagrams per major sub-system showing proper wiring.
- D. Submit standard catalog literature which includes performance specifications indicating compliance to the specification.

1 1.06 SYSTEM OPERATION

- 2 A. It shall be the contractor's responsibility to make all proper adjustments to assure owner's satisfaction  
3 with the occupancy system.

4 PART 2 - PRODUCTS

5 2.01 ACCEPTABLE MANUFACTURERS

- 6 A. The Watt Stopper, Inc.  
7 B. Or Equivalent Devices by the Following Manufacturers  
8 1. Hubbell  
9 2. Leviton  
10 3. Sensor Switch

11 2.02 SYSTEM OPERATION

- 12 A. All products shall be Watt Stopper product numbers:  
13 1. Ceiling Sensors: W-500A, W-1000A, W-2000A, W-2000H, W-PIR, DT-100L, CI-100, CI-  
14 200.  
15 2. Wall Sensors: WI-120A, WI-277A, WS-120, WS-277, WM-120, WM-277.  
16 3. Power and Slave Packs: A-120E, A-277E, S-120/277.  
17 4. Low Temperature: CB-100, CB-200.  
18 B. Wall switch sensors shall be capable of detection of motion at desk top level up to 300 square feet,  
19 and gross motion up to 1,000 square feet.  
20 C. Wall switch sensors shall accommodate loads from 0 to 800 watts at 120 volts; 0 to 1,000 watts at 277  
21 volts and shall have 180 degree coverage capability.  
22 D. Bi-level wall switch sensors shall accommodate loads from 0 to 800 watts at 120 volts; 0 to 1,000  
23 watts to 277 volts.  
24 E. Passive Infrared sensors shall have a multiple segmented Lodif Fresnel lens, in a multiple-tier  
25 configuration, with grooves-in to eliminate dust and residue build-up.  
26 F. Passive Infrared and Dual Technology sensors shall have fully automatic operation, offer daylighting  
27 foot-candle adjustment control and be able to accommodate dual level lighting.  
28 G. All sensors shall be capable of operating normally with electronic ballast, PL lamp systems, and rated  
29 motor loads.  
30 H. Coverage of sensors shall remain constant after sensitivity control has been set. No automatic  
31 reduction shall occur in coverage due to the cycling of air conditioner or heating fans.  
32 I. All sensors shall have readily accessible, user adjustable controls for time delay and sensitivity.  
33 Controls shall be recessed to limit tampering.  
34 J. In the event of failure, a bypass manual override shall be provided on each sensor. When bypass is  
35 utilized, lighting shall remain on constantly or control shall divert to a wall switch until sensor is  
36 replaced. This control shall be recessed to prevent tampering.  
37 K. Ultrasonic operating frequency shall be crystal controlled to within plus or minus 0.005% tolerance  
38 to assure reliable performance and eliminate sensor cross talk. Sensors using multiple frequencies are  
39 not acceptable.  
40 L. All sensors shall provide a method of indication to verify that motion is being detected during testing  
41 and that the unit is working.  
42

- 1 M. Where specified, sensor shall have an internal additional isolated relay with Normally Open,  
2 Normally Closed, and Common outputs for use with HVAC control, Data Logging, and other control  
3 options. Sensors utilizing separate components to achieve this function are not acceptable.
- 4 N. All sensors shall have no leakage current to load in manual or in Auto/Off mode for safety purposes  
5 and shall have voltage drop protection.
- 6 O. The Contractor shall certify in writing that installed sensors comply with the specified California  
7 Energy Commission criteria for ultrasonic sound.
- 8 P. All sensors shall have UL rated, 94V-0 plastic enclosures.

9 2.03 CIRCUIT CONTROL HARDWARE - CU

- 10 A. Control Units - For ease of mounting, installation and future service, control unit(s) shall be able to  
11 mount on external J boxes and be integrated self-contained unit consisting internally of load switching  
12 control relay and a transformer to provide low-voltage power to a minimum of two (2) sensors.
- 13 B. Relay Contacts shall have ratings of:
  - 14 1. 13A - 120 VAC Tungsten
  - 15 2. 20A - 120 VAC Ballast
  - 16 3. 20A - 277 VAC Ballast

17 2.04 CONTROL WIRING

- 18 A. Control wiring between sensors and controls units shall be Class II, 18-24 AWG stranded U.L.  
19 Classified, PVC insulated or Teflon jacketed cable approved for use in plenums, where applicable.

20 PART 3 - EXECUTION

21 3.01 INSTALLATION

- 22 A. It shall be the contractor's responsibility with the supplier's assistance to locate and aim sensory in the  
23 correct location required for complete and proper volumetric coverage within the range of coverage(s)  
24 of controlled areas. Rooms shall have ninety (90) to one hundred (100) percent coverage to  
25 completely cover the controlled area to accommodate all occupancy habits of single or multiple  
26 occupants at any location within in the room(s). The locations and quantities of sensors shown on the  
27 drawings are diagrammatic and indicate only rooms which are to be provided with sensors. The  
28 contractor shall provide additional sensors if required to properly and completely cover the respective  
29 room.
- 30 B. It is the contractor's responsibility to arrange a pre-installation meeting with the manufacturer's  
31 factory authorized representative, at the owner's facility, to verify placement of sensors and  
32 installation criteria.
- 33 C. Proper judgement must be exercised in executing the installation in the available space and to  
34 overcome local difficulties due to space limitations or interference of structural components. The  
35 contractor shall also provide, at the owner's facility, the training necessary to familiarize the owner's  
36 personnel with the operation, use, adjustment, and problem solving diagnosis of the occupancy  
37 sensing devices and systems, or;

38 END OF SECTION 26 09 23

Page Intentionally Left Blank



SECTION 26 20 00

BASIC MATERIALS AND METHODS

PART 1 - GENERAL

1.01 SCOPE

- A. Conditions of the Contract and portions of Division One of this Project Manual apply to this Section as though repeated herein.

1.02 REFERENCES

- A. National Electrical Manufacturer's Association (NEMA).
- B. Underwriters Laboratories, Inc. (UL).
- C. American Society for Testing and Materials (ASTM).
- D. National Fire Protection Association (NFPA).

1.03 SUBMITTALS

- A. Product Data
  - 1. Submit for disconnects, motor starters, panelboards, circuit breakers, overcurrent protective devices, transformers, and mini-power centers.
  - 2. Product data sheets with printed installation instructions.
- B. Shop Drawings:
  - 1. Submit for motor starters.
  - 2. Show enclosure dimensions, nameplate nomenclature, electrical ratings, and thermal unit schedule.
  - 3. Wiring diagrams and schematics.
- C. Approval of equipment supplied in this section is contingent upon Contractor verification of available fault current from electric utility.
  - 1. Notify ENGINEER if available fault current is higher than specified equipment.
- D. Submit in accordance with Section 01340.
- E. Operation and Maintenance (O&M) Data:
  - 1. Maintenance data for materials and products for inclusion in Operating and Maintenance specified in Section 01730.
  - 2. Submit in accordance with Section 01340 and 01730.
- F. Test Results:
  - 1. Report of field tests and observations certified by Contractor.

1.04 QUALITY ASSURANCE

- A. Items provided under this section shall be listed and labeled by UL or other Nationally Recognized Testing Laboratory (NRTL).
  - 1. Term "NRTL" shall be as defined in OSHA Regulation 1910.7.
  - 2. Terms "listed" and "labeled" shall be as defined in National Electrical Code, Article 100.
- B. Regulatory Requirements:
  - 1. National Electrical Code: Components and installation shall comply with NFPA 70.
  - 2. Local codes and ordinances.

1 PART 2 - PRODUCTS

2 2.01 ELECTRICAL METALLIC TUBING (EMT)  
3 INTERMEDIATE METALLIC CONDUIT (IMC)  
4 GALVANIZED RIGID STEEL CONDUITS (GRS)

5 A. Manufacturers:

- 6 1. Allied Steel
- 7 2. Omega
- 8 3. Wheatland
- 9 4. Columbia

10 B. Manufacturer's standard lengths and size.

11 C. Protected inside and out by hot-dipped galvanized or electrogalvanized coating.

12 D. Minimum size: 1/2 inch.

13 E. Do not use aluminum conduit.

14 2.02 PLASTIC CONDUIT (PVC)

15 A. Manufacturers:

- 16 1. Carlon.
- 17 2. Genova.
- 18 3. Certainteed.

19 B. Standard lengths and sizes.

20 C. Schedule 40 or 80, heavy wall rigid plastic (PVC) conduit manufactured to NEMA TC2 standards,  
21 UL listed, and as required by NEC.

22 D. Rated for 90 degrees C cable.

23 E. Minimum size: 2" inches.

24 2.03 FLEXIBLE CONDUIT

25 A. Manufacturers:

- 26 1. Triangle PWC, Inc.
- 27 2. Anaconda
- 28 3. Flexsteel
- 29 4. American Flexible Conduit

30 B. Galvanized flexible steel.

31 C. Standard conduit sizes.

32 D. Minimum Size: 1/2 inch.

33 2.04 LIQUIDTIGHT FLEXIBLE CONDUIT

34 A. Manufacturers:

- 35 1. O-Z/Gedney Company
- 36 2. American Flexible Conduit
- 37 3. Flex-Guard, Inc.
- 38 4. Liquatite
- 39 5. Anaconda

40 B. Galvanized flexible steel.

- 1 C. Standard conduit sizes.
- 2 D. Minimum Size: 1/2 inch.
- 3 E. Heavy wall PVC jacket.
- 4 2.05 FITTINGS
- 5 A. Manufacturers:
  - 6 1. Appleton Electric Company.
  - 7 2. Steel City, American Electric.
  - 8 3. Oz-Gedney Co.
- 9 B. Steel or malleable iron, zinc galvanized or cadmium plated.
- 10 C. Do not use indentor type fittings. Set screw fittings are acceptable.
- 11 D. Do not use aluminum or die cast fitting.
- 12 E. EMT IMC and GRS Connectors and Couplings:
  - 13 1. Threaded.
  - 14 2. Insulated throat.
  - 15 3. Rain and concrete type.
- 16 F. Flexible Conduit Connectors and Couplings:
  - 17 1. Threaded.
  - 18 2. Insulated throat.
  - 19 3. Grounding type.
- 20 G. Liquidtight Flexible Conduit Fittings:
  - 21 1. Liquidtight.
  - 22 2. Insulated throat.
  - 23 3. Threaded.
  - 24 4. Grounding type.
- 25 H. Expansion Joints:
  - 26 1. Conduit expansion fittings complete with copper bonding jumper, Crouse-Hinds Type XJ.
  - 27 2. Conduit expansion/deflection fittings with copper bonding jumper, Crouse-Hinds Type XD.
- 28 I. Seals:
  - 29 1. Wall entrance, Appleton Type FSK or FSC.
- 30 J. Drain Fittings:
  - 31 1. Automatic Drain Breather:
    - 32 a. Explosionproof.
      - 33 i. Safe for Class I, Groups C and D.
    - 34 b. Capable of passing minimum 25 cc water/minimum and minimum 0.05 cubic foot
    - 35 air/minimum at atmospheric pressure.
  - 36 2. Condensate Drain:
    - 37 a. Conduit outlet body, Type T.
    - 38 b. Threaded, galvanized plug with 3/16 inch drilled holed through plug.
- 39 2.06 WIRES, CABLES, AND CONNECTORS
- 40 A. Manufacturers:
  - 41 1. Wire and Cable:
    - 42 a. Continental

- 1 b. Southwire.
- 2 c. Rome Cable.
- 3 d. Houston Wire and Cable.
- 4 e. Beldon.
- 5 f. Dekoron.
- 6 g. Royal
- 7 h. South
- 8 i. General
- 9 2. Connectors:
- 10 a. Burndy.
- 11 b. Thomas and Betts.
- 12 c. Blackburn, American Electric.
- 13 3. Electrical Tape:
- 14 a. 3M Scotch Brand.
- 15 b. Plymouth.
- 16 c. or equal.
- 17 B. Copper wire only.
- 18 C. 600 v insulation (ASTM standard compounds) and color code conductors for low voltage (secondary
- 19 feeders and branch circuits) as required by NEC.
- 20 1. Type THWN-2 Stranded: Single conductor No. 12 AWG minimum for branch circuit and
- 21 feeder conductors size No. 8 AWG and smaller.
- 22 2. Type XHHW-2 Stranded: Single conductor for branch circuits, feeders and service conductors
- 23 larger than No. 8 AWG.
- 24 3. Provide grounding conductor with same insulation as circuit conductors when run with circuit
- 25 conductors.
- 26 4. Type THWN-2 Stranded: Single conductor No. 12 AWG minimum for 120 v control wiring
- 27 and No. 14 AWG minimum for graphic indication, nonshielded instrumentation and other
- 28 control wiring operating at less than 120 v unless otherwise noted on Drawings.
- 29 a. Provide high density polyethylene jacketed multi-wire cable assemblies in underground
- 30 conduit or duct.
- 31 D. Joints, Taps, and Splices:
- 32 1. Joints, Taps, and Splices in Conductors No. 10 AWG and Smaller: UL listed compression
- 33 spring-type solderless connectors with plastic cover.
- 34 2. Joints, Taps, and Splices in Conductors No. 8 AWG and Larger: Solderless two or four-bolt
- 35 compression type connectors of type that will not loosen under vibration or normal strains.
- 36 3. Terminations: Compression-type crimp lugs.
- 37 2.07 BOXES
- 38 A. Manufacturer:
- 39 1. Interior Outlet Boxes:
- 40 a. Appleton Electric Company.
- 41 b. Raco.
- 42 c. Steel City, American Electric.
- 43 2. Weatherproof Outlet Boxes:
- 44 a. Appleton Electric Company.
- 45 b. Crouse-Hinds Company.
- 46

- 1 c. O-Z/Gedney company.
- 2 d. Perfect-Line, American Electric.
- 3 3. Junction and Pull Boxes:
- 4 a. Hoffman Engineering Company.
- 5 b. Keystone Columbia, Inc.
- 6 c. Electromate.
- 7 B. Outlet Boxes - Flush Mounted:
- 8 1. Wall Outlets: Square corner, galvanized masonry type with internally mounted ears or 4-
- 9 inches square with raised cover having square corners and internally mounted ears.
- 10 2. Ceiling Lighting Fixture Outlet Boxes: 4-inch square galvanized box with raised cover set
- 11 flush with finished surface, complete with 3/8 inch fixture stud.
- 12 C. Outlet Boxes - Surface Mounted:
- 13 1. General Use: 4-inches square with raised device cover.
- 14 2. Weatherproof: Cast galvanized with threaded hub.
- 15 3. Safety outlet enclosure - Tay Mac Co. - Verify outlet configuration.
- 16 4. Hazardous Locations: Cast galvanized approved for classification of area.
- 17 D. Junction and Pull Boxes:
- 18 1. Fabricate from code gauge galvanized steel, with covers held in-place by corrosion resistant
- 19 machine screws.
- 20 2. Size as required by code for number of conduits and conductors entering and leaving box.
- 21 3. Provide with welded seams where applicable, and equipment with corrosion resistant nuts,
- 22 bolts, screws, and washers.
- 23 4. Finish with rust inhibiting primer.
- 24 2.08 FIRE RATED THROUGH FLOOR FITTINGS
- 25 A. None required.
- 26 2.09 WIRING DEVICES
- 27 A. Manufacturers:
- 28 1. Hubbell Wiring Device Division.
- 29 2. Pass and Seymour, Inc.
- 30 3. Leviton
- 31 4. Cooper Wiring Devices
- 32 B. Fabricated Devices:
- 33 1. Factory-fabricated, specification grade wiring devices in type, color, and electrical rating for
- 34 service indicated. Ivory color or as selected by ENGINEER OR OWNER.
- 35 2. Wiring devices of one manufacturer.
- 36 3. See Drawing symbol schedule for identification of device type.
- 37 C. Switches:
- 38 1. General Use Lighting Switches: 20 amp toggle, equal to Hubbell No. 1221-I series.
- 39 2. Switches controlling equipment, operation of which is not evident from switch position, shall
- 40 include flush neon pilot light in conjunction with proper switch. Each switch shall be complete
- 41 with engraved plate to identify equipment being controlled (white letters on black, 1/8 inch
- 42 high minimum).
- 43

- 1 D. Receptacles:
- 2 1. General use duplex receptacles: NEMA No. 5-20R, grounding type, 20 amp Hubbell No. 5362
- 3 Specification Grade.
- 4 2. Special purpose receptacles as shown on Drawings and schedules.
- 5 3. GFI receptacles shall be Hubbell GFR5352IA
- 6 E. Wiring Device Plates and Covers:
- 7 1. Wall plates for wiring devices with ganging and cut-outs as indicated, provided with metal
- 8 screws for securing plates to devices, screw heads colored to match finish of plate.
- 9 2. Plates for Flush Mounted Devices: Equal to Sierra P line specifications grade Type No. 430
- 10 brushed stainless steel.
- 11 3. Telephone outlet configuration to match telephone outlet jack or cable.
- 12 4. Device plates for surface mounted Type FS or FD boxes to be Type FSK galvanized steel.
- 13 5. Device plates for surface mounted, 4-inch square bossed to be ½ inch raised galvanized steel
- 14 covers.
- 15 6. Weatherproof outlet enclosure for exterior devices or devices in damp locations to be marked
- 16 galvanized gray cast malleable with gasketed lift cover plate as shown on Drawings. Suitable
- 17 for wet locations while in use. Enclosure must be gasketed. Provide Intermatic WP1010MC,
- 18 WP1010HMC, or WP1030MC with appropriate mounting base(s) and inserts.
- 19 2.10 MOTOR STARTERS
- 20 A. None required.
- 21 2.11 MOTOR AND CIRCUIT DISCONNECTS
- 22 A. Manufacturers:
- 23 1. Eaton/Cutler-Hammer
- 24 2. Square D
- 25 3. General Electric
- 26 B. Enclosed Circuit Breaker Construction:
- 27 1. Dual cover interlock.
- 28 2. External trip indication.
- 29 3. Provisions for control circuit interlock.
- 30 4. Padlock provisions for padlock in Off position.
- 31 5. Handle attached to box, not cover.
- 32 6. Handle position indicates On, Off or Tripped.
- 33 7. Provisions for insulated or groundable neutral.
- 34 C. Safety Switches:
- 35 1. NEMA heavy duty Type HD.
- 36 2. Dual cover interlock.
- 37 3. Visible blades.
- 38 4. Provisions for control circuit interlock.
- 39 5. Pin type hinges.
- 40 6. Tin plated current carrying parts.
- 41 7. Quick make and break operator mechanism.
- 42 8. Handle attached to box, not cover.
- 43 9. Handle position indication, On in up position and Off in down position.
- 44 10. Padlock provisions for up to 3 padlocks in Off position.

- 1 11. UL listed lugs for type and size of wire specified.
- 2 12. Spring reinforced fuse clips for Class R fuses.
- 3 13. Provisions for insulated or groundable neutral.
- 4 14. UL listed short circuit rating 200,000 RMS amp with Class R fuses.
- 5 D. Enclosures:
- 6 1. Indoor: NEMA 1 code gauge steel with rust inhibiting primer and baked enamel finish.
- 7 2. Outdoor: NEMA 3R code gauge zinc coated steel with baked enamel finish.

8 2.12 FUSES

- 9 A. Manufacturers:
- 10 1. Bussmann
- 11 2. Gould Shawmut
- 12 3. Littlefuse
- 13 4. Brush
- 14 B. 250 v. Fuses:
- 15 1. Class RK-1, 1-end rejection or to fit mountings specified, 1/10 to 600 amps, 200,000-amp
- 16 interrupting rating.
- 17 a. Gould Shawmut Tri-Onic TR-R, dual element, time delay with short circuit protection
- 18 for motor, transformer, welder, feeder, and main service protection.
- 19 C. 600v Fuses:
- 20 1. Class RK-1, 1-end rejection or to fit mountings specified, 1/10 to 600 amps, 200,000-amp
- 21 interrupting rating.
- 22 a. Gould Shawmut Tri-Onic TR-R, dual element, time delay with short circuit protection
- 23 for motor, transformer, welder, feeder and main service protection.
- 24 2. Class L, bolt-in 601 to 6,000 amps, 200,000-amp interrupting rating.
- 25 a. Gould Shawmut A48Y, time delay for overload and short circuit protection for motor,
- 26 transformer, feeder, and main service protection.
- 27 3. Class CC, fast acting, single element, 1/10 to 30 amps, 200,000-amp interrupting rating.
- 28 a. Gould Shawmut ATDR, UL listed for motor control circuits, lighting ballasts, control
- 29 transformers, and street lighting fixtures.
- 30 D. Spare Fuses:
- 31 1. 10%, minimum of 3, of each type and rating of installed fuses.
- 32 E. Spare Fuse Cabinet:
- 33 1. Cabinet: Wall-mounted, 18-gauge minimum steel unit with full-length, recessed piano-hinged
- 34 door with key coded cam lock and pull.
- 35 2. Size: Provide for orderly storage of spare fuses of this project plus 15% spare capacity,
- 36 minimum.
- 37 3. Finish: Gray baked enamel.
- 38 4. Cabinet Door: Bear legend in stencilled 1-1/2 inch high letters, "Spare Fuses."

39 2.13 PANELBOARDS

- 40 A. Panelboards are existing.

41 2.14 MOLDED CASE CIRCUIT BREAKERS

- 42 A. Manufacturers:
- 43 1. Eaton to match existing panels.

1 2.15 GROUND-FAULT CIRCUIT INTERRUPTER RECEPTACLES (GFCI)

- 2 A. Ratings:
  - 3 1. 120 vac.
  - 4 2. 20 amp.
- 5 B. Tripping Requirement:
  - 6 1. UL Class A.
- 7 C. Construction:
  - 8 1. Shallow depth.
  - 9 2. Line and load terminal screws.
  - 10 3. Noise suppression.
  - 11 4. Feed through.
  - 12 5. Standard duplex wall plates shall fit.
  - 13 6. NEMA 5-20R configuration.
- 14 D. Meet requirements of UL 943 ground-fault circuit interrupters.

15 2.16 GROUNDING AND BONDING

- 16 A. Products: Of types indicated and of sizes and ratings to comply with NEC. Where types, sizes,  
17 ratings, and quantities indicated are in excess of NEC requirements, more stringent requirements and  
18 greater size, rating, and quantity indications govern.
- 19 B. Conductor Materials: Copper.
- 20 C. Conform to NEC Table 8, except as otherwise indicated, for conductor properties, including  
21 stranding.
- 22 D. Equipment Grounding Conductor: Green insulated.
- 23 E. Grounding Electrode Conductor: Stranded cable.
- 24 F. Bare Copper Conductors:
  - 25 1. Solid Conductors: ASTM B3.
  - 26 2. Assembly of Stranded Conductors: ASTM B8.
  - 27 3. Tinned Conductors: ASTM B33.
- 28 G. Ground Bus: Bar annealed copper bars of rectangular cross section.
- 29 H. Braided Bonding Jumpers: Copper tape, braided No. 30 gage bar copper wire, terminated with copper  
30 ferules.
- 31 I. Bonding Strap Conductor/Connectors: Soft copper, 0.05 inches thick and 2 inches wide, except as  
32 indicated.
- 33 J. Connector Products
  - 34 1. General: Listed and labeled as grounding connectors for materials used.
  - 35 2. Pressure Connectors: High-conductivity-plated units.
  - 36 3. Bolted Clamps: Heavy-duty units listed for application.
  - 37 4. Exothermic Welded Connections: Provide in kit form and select for specific types, sizes, and  
38 combinations of conductors and other items to be connected.

39 PART 3 - EXECUTION

40 3.01 GENERAL

- 41 A. Install products in accordance with NEC, manufacturer's instructions, applicable standards, and  
42 recognized industry practices to ensure products serve intended function.



- 1 3.02 CONDUITS AND CONDUIT FITTINGS
- 2 A. Complete conduit installation prior to installing cables.
- 3 B. Unless specifically indicated otherwise on Drawings, use rigid galvanized steel conduit for general  
4 wiring.
- 5 C. Provide watertight conduit system where installed in wet places, underground or where buried in  
6 masonry or concrete.
- 7 D. EMT conduit may be used for conduit sizes up to 4 inches.
- 8 E. Conduit shall be run concealed except exposed surface conduit may be installed where noted on  
9 Drawings or where concealment found to be impractical or impossible, and only with approval of  
10 ENGINEER.
- 11 F. Continuous from outlet to outlet and from outlets to cabinets, junction or pull boxes.
- 12 G. Enter and secure to boxes ensuring electrical continuity from point of service to outlets.
- 13 H. Conduit runs extending through areas of different temperature or atmospheric conditions or partly  
14 indoors and partly outdoors shall be sealed, drained, and installed in manner preventing drainage of  
15 condensed or entrapped moisture into cabinets, motors or equipment enclosures.
- 16 I. Run conduits within concrete structures parallel to each other and spaced on center of at least three  
17 times conduit trade diameter with minimum 2-inch concrete covering. Conduits over 1 inch may not  
18 be installed in slab without approval of ENGINEER.
- 19 J. Run exposed conduits parallel to or at right angles with lines of building.
- 20 K. Route conduit runs above suspended acoustical ceilings not interfering with tile panel removals.
- 21 L. Secure conduit in-place with not less than 1 malleable corrosion-proof alloy strap or hanger per 8 feet  
22 of conduit.
- 23 1. Do not use perforated strapping.
- 24 M. Connections to Motors and Equipment Subject to Vibration:
- 25 1. Flexible steel conduit not over 3 feet long or where exposed in mechanical and utility areas and  
26 not subjected to moisture, dirt, and fumes.
- 27 2. Liquidtight flexible conduit not over 3 feet long where exposed in finished areas or where  
28 subject to moisture, dirt, fumes, oil, corrosive atmosphere, exposed or concealed, with  
29 connectors to ensure liquid tight, permanently grounded connection. Locate where least  
30 subject to physical abuse.
- 31 N. Use double lock nuts and insulated bushings with threads fully engaged.
- 32 O. Connectors at fixture bodies and boxes shall be rigidly secured with galvanized lock nut and bushing.
- 33 P. Cap conduits after installation to prevent entry of debris.
- 34 Q. Install conduit expansion fittings complete with bonding jumper in following locations.
- 35 1. Conduit runs crossing structural expansion joint.
- 36 2. Conduit runs attached to two separate structures.
- 37 3. Conduit runs where movement perpendicular to axis of conduit may be encountered.
- 38 R. Install 4 feet-0 inch to 6 feet-0-inch flexible steel conduit drops from independent junction box  
39 mounted above ceiling and accessible from below ceiling to recessed ceiling mounted equipment.  
40 Allow for positioning of equipment to tile increments.
- 41 S. Negotiate beams and changes in ceiling heights with LB conduit fittings on outside corners and ells  
42 on inside corners. Arrange bends and offsets in parallel conduits to present neat symmetrical  
43 appearance.
- 44 T. In precast areas, run conduits in insulation space or in floor topping without crossing conduits, using  
45 3/4 in. maximum conduit size.

- 1 U. Core drill through reinforced concrete with approval of ENGINEER.
- 2 V. Split, crushed or scarred conduit not acceptable.
- 3 W. Do not route over boiler, incinerator or other high temperature equipment.
- 4 X. Flexible metal conduit can only be used for final connections to motors, transformers, or to light
- 5 fixtures above suspended ceilings.

6 3.03 SURFACE METAL RACEWAY

- 7 A. Mount to surface with No. 8 flathead fasteners or approved support clips.
- 8 B. Do not pinch wires.
- 9 C. Remove metal burrs and sharp edges.
- 10 D. Provide bushing.
- 11 E. Install in accordance with manufacturer's recommendations.
- 12 F. Provide covers where two lengths come together.

13 3.04 WIRE AND CABLE

- 14 A. Run wire and cable in conduit unless otherwise indicated on Drawings.
- 15 B. On branch circuits, use standard colors.
- 16 C. Each tap, joint or splice in conductors No. 8 AWG and larger shall be taped with 2 half-lap layers of
- 17 vinyl plastic electrical tape and finish wrap of color coding tape, where required by code.
- 18 D. Run ground wire with power circuits; conduit shall not be grounding path.
- 19 E. Color Coding: Conductors for lighting and power wiring as indicated below.

20	<u>Phase</u>	<u>208/120v</u>	<u>480/277v</u>
21	A	Black	Brown
22	B	Red	Orange
23	C	Blue	Yellow
24	Neutral	White	Gray
25	Ground	Green	Green

26 3.05 BOXES

- 27 A. Install knockout closures to cap unused knockout holes where blanks have been removed.
- 28 B. Locate boxes to ensure accessibility of electrical wiring.
- 29 C. Secure boxes rigidly to subsurface upon which being mounted or solidly embed boxes in concrete or
- 30 masonry. Do not support from conduit.
- 31 D. Do not burn holes, use knockout punches or saw.
- 32 E. Provide outlet box accessories as required for each installation such as mounting brackets, fixture
- 33 study, cable clamps, and metal straps for supporting outlet boxes compatible with outlet boxes being
- 34 used and meeting requirements of individual wiring situations.
- 35 F. Location of outlets and equipment shown on Drawings is approximate. Verify exact location.
- 36 G. Minor modification in location of outlets and equipment is considered incidental up to distance of 10
- 37 feet with no additional compensation, provided notification of modification is given prior to roughing
- 38 in of outlet.
- 39 H. Flush outlets shall have edges or plaster flush with finished wall or ceiling surfaces so plates can be
- 40 drawn tightly to wall or ceiling surfaces.
- 41 I. Mounting heights:
  - 42 1. Shall conform to ADA guidelines.

- 1                   2.    In general, unless otherwise shown on Drawings:
- 2                   a.    Switches: 48 inches above floor to top of box.
- 3                   b.    AC Receptacles and Telephone Outlets: 15 inches above floor to bottom of box or 6
- 4                   inches above counters, counter backslashes in finished areas; 48 inches to top of box
- 5                   above floor in unfinished areas.
- 6                   c.    Wall Bracket Lighting Fixtures: 8 inches above mirrors or 6 feet-6 inches above floor.
- 7                   d.    Pushbuttons: 48 inches above floor to top of box.
- 8                   e.    Motor Starters and Disconnect Switches: 60 inches above floor.
- 9                   i.    Thermostats: 48 inches above floor.
- 10                  f.    Bells and Horns: 8 feet-0 inches above floor.
- 11                  g.    Clocks: 8 ft.-0 inches above floor.
- 12                  h.    Fire Alarm visual signals 80" above floor.
- 13                  i.    Emergency Battery Units: 8 ft. - 0 inches above floor or 12" below ceiling.
- 14                  J.    Do not install boxes back to back or through wall. Offset outlet boxes on opposite sides of wall,
- 15                  minimum 12 inches.
- 16                  K.    Where emergency switches occur adjacent to normal light switches, install in separate boxes in
- 17                  accordance with NEC and device plate color coding separation.
- 18                  L.    Light Fixture Outlet Boxes:
- 19                   1.    Securely mount with approved type bar hangers spanning structural members to support
- 20                   weight of fixture.
- 21                   2.    Do not support from conduit.
- 22                   3.    Equip with 3/8-inches fixture stud and tapped fixture ears.
- 23    3.06   FIRE RATED THROUGH FLOOR FITTINGS
- 24            A.    None required.
- 25    3.07   WIRING DEVICES
- 26            A.    Do not install devices until wiring is complete.
- 27            B.    Do not use terminals on wiring devices (hot or neutral) for feed-through connections, looped or
- 28            otherwise. Make circuit connections by using wire connectors and pigtails.
- 29            C.    Install gasket plates for devices or system components having light emitting features such as switch
- 30            with pilot light and dome lights. Where installed on rough textured surfaces, seal with black self-
- 31            adhesive polyfoam.
- 32            D.    Ground receptacles with insulated green ground wire from device ground screw to bolted outlet box
- 33            connection or as shown on Drawings.
- 34            E.    Wrap wiring devices with insulating tape.
- 35            F.    Install emergency switches which occur adjacent to normal light switches in separate boxes to
- 36            maintain systems isolation in accordance with NEC.
- 37    3.08   OVERCURRENT PROTECTIVE DEVICES.
- 38            A.    Install fuses just prior to energizing equipment.
- 39            B.    Locate circuit breakers as shown on Drawings.
- 40            C.    Install GFCI receptacles as required by NEC.
- 41    3.09   PANELBOARDS
- 42            A.    Flush or surface mount as specified on Drawings and schedules.

- 1 B. Support panel cabinets independently to structure with no weight bearing on conduits.
- 2 C. Install recessed Panelboards to allow cover to be drawn tight against wall to provide neat appearance.
- 3 D. Install panelboards so top breaker is not higher than 6 feet-0 inches above floor.
- 4 E. Adjacent panel cabinets shall be same size and mounted in horizontal alignment.
- 5 F. Install typewritten directory in each panelboard, accurately indicating rooms or equipment being
- 6 served after final circuit changes have been made to balance circuit loads.
- 7 G. Install four spare 1 inch conduits from top of each flush mounted panelboard to area above ceiling for
- 8 future use. On flush mounted panelboards located on first and higher level floors, provide two spare 1
- 9 inch conduits from bottom of panelboard to ceiling area of floor below for future use.

10 3.10 GROUNDING AND BONDING

- 11 A. Application
  - 12 1. Equipment Grounding Conductor Application: Comply with NEC Article 250 for sizes and
  - 13 quantities of equipment grounding conductors, except where larger sizes or more conductors
  - 14 are indicated.
    - 15 a. Install separate insulated equipment grounding conductors with circuit conductors.
    - 16 Raceway may be used as equipment ground conductor where feasible in non-hazardous
    - 17 areas and permitted by NEC for lighting circuits. Install insulated equipment ground
    - 18 conductor in nonmetallic raceways unless designated for telephone or data cables.
- 19 B. Installation
  - 20 1. General: Ground electrical systems and equipment in accordance with NEC requirements
  - 21 except where Drawings or Specifications exceed NEC requirements.

22 3.11 FIELD QUALITY CONTROL

- 23 A. Control Circuits, Branch Circuits, Feeders, Motor Circuits, and transformers:
  - 24 1. Megger check to phase-to-phase and phase-to-ground insulation levels.
    - 25 a. Do not megger check solid state equipment.
  - 26 2. Continuity.
  - 27 3. Short circuit.
  - 28 4. Operational check.
- 29 B. Wiring Devices:
  - 30 1. Test receptacles with Hubbell 5200, Woodhead 1750 or equal tester for correct polarity, proper
  - 31 ground connection, and wiring faults.

32 3.12 ADJUSTMENT AND CLEANING

- 33 A. Circuit Breakers:
  - 34 1. Adjustable settings shall be set to provide selective coordination, proper operation, and
  - 35 compliance with NEC.
- 36 B. Restore damaged areas on PVC jacketed rigid conduit with spray type touch-up coating compound or
- 37 as directed by manufacturer.
- 38 C. Pull cleaning plug through conduits to clear of dirt, oil, and moisture.

39 END OF SECTION 26 20 00

SECTION 26 51 13

LIGHTING

PART 1 - GENERAL

1.01 RELATED DOCUMENTS

- A. Conditions of the Contract and portions of Division One of this Project Manual apply to this Section as though repeated herein.

1.02 SUMMARY

- A. Section Includes:
  - 1. Interior lighting fixtures.
  - 2. Exterior lighting fixtures.
  - 3. Lamps.
  - 4. Ballasts.
  - 5. Emergency lighting units.

1.03 REFERENCES

- A. American National Standards Institute (ANSI):
  - 1. C78 Series - Lamps.
  - 2. C82.2-84 - Fluorescent Lamp Ballasts.
  - 3. C82.4-85 - Ballasts for High-Intensity-Discharge and Low-Pressure Sodium Lamps (Multiple-Supply Type).
  - 4. ANSI C2-90 - National Safety Code.
- B. Institute of Electrical and Electronics Engineers (IEEE):
  - 1. C62.41-91 - IEEE Recommended Practice on Surge Voltages in Low-Voltage AC Power Circuits.
- C. National Fire Protection Association (NFPA):
  - 1. 70-93 - National Electric Code.
- D. Underwriters Laboratory (UL):
  - 1. 844-90 - UL Standard for Safety Electric Lighting Fixtures for Use in Hazardous (Classified) Locations.
  - 2. 924-90 - UL Standard for Safety Emergency Lighting and Power Equipment.
  - 3. 935-84 - UL Standard for Safety Florescent-Lamp Ballast.
  - 4. 1092 (P) - UL Standard for Safety Proposed First Edition of the Standard for Process Control Equipment.
  - 5. 1570-88 - UL Standard for Safety Florescent Lighting Fixtures.
  - 6. 1571-91 - UL Standard for Safety Incandescent Lighting Fixtures.
  - 7. 1572-91 - UL Standard for Safety High Intensity Discharge Lighting Fixtures.
  - 8. 1573-85 - UL Standard for Safety Stage and Studio Lighting Units.
  - 9. 1574-87 - UL Standard for Safety Track Lighting Systems.
  - 10. UL 773-87 - UL Standard for Safety Plug-In, Locking Type Photo controls for Use with Area Lighting.

- 1 E. RoHS - Restriction of Hazardous Substances. Council of the European Union (EC) Directive  
2 2002/95/EC on the restriction of the use of certain hazardous substances in electrical and  
3 electronic equipment.
- 4 F. LM-79-08 (or latest) - IES Approved Method for the Electrical and Photometric  
5 Measurements of Solid-State Lighting Products.
- 6 G. LM-80-08 (or latest) - IES Approved Method for Measuring Lumen Maintenance of LED  
7 Light Sources.
- 8 H. TM-21-11 (or latest) - IES Technical Memorandum on Projecting Long Term Lumen  
9 Maintenance of LED Light Sources.
- 10 I. NEMA SSL 1-2010 (or latest) - Electronic Drivers for LED Devices, Arrays, or Systems.

#### 11 1.04 DEFINITIONS

- 12 A. Emergency Lighting Unit: Fixture with integral emergency battery power supply and means  
13 for controlling and charging battery. Also known as emergency light set. Emergency units are  
14 available with integral lamps only.
- 15 B. Fixture: Complete lighting unit, exit sign, or emergency lighting unit. Fixtures include lamps  
16 and parts required to distribute light, position and protect lamps, and connect lamps to power  
17 supply. Internal battery powered exit signs and emergency lighting units also include battery  
18 and means for controlling and recharging battery. Emergency lighting units are available with  
19 and without integral lamp heads and lamps.
- 20 C. Luminaire: Fixture.
- 21 D. Average Life: Time after which 50% will have failed and 50% will have survived under  
22 normal conditions.

#### 23 1.05 SUBMITTALS

- 24 A. Product Data:
  - 25 1. Describe fixtures, lamps, ballasts, poles, emergency lighting units, and accessories. Arrange  
26 product data for fixtures in order of fixture designation. Include data on features and  
27 accessories and following information:
    - 28 a. Outline drawings of fixtures indicating dimensions and principal features.
    - 29 b. Electrical ratings and photometric data with specified lamps and certified results of  
30 independent laboratory tests.
    - 31 c. Data on batteries and chargers of emergency lighting units.
  - 32 B. Shop Drawings: Detail nonstandard fixtures and indicating dimensions, weights, methods of  
33 field assembly, components, features, and accessories.
  - 34 C. Samples: Submit sample of fixture if different than specified.
  - 35 D. Miscellaneous:
    - 36 1. For substitutes only, product certifications signed by manufacturers of lighting fixtures  
37 certifying that their fixtures comply with specified requirements.
    - 38 2. Warranty for rechargeable battery.
    - 39 3. Coordination drawings for fixtures that require coordination with other equipment installed in  
40 same space.
  - 41 E. Submit in accordance with Division 1.

1 1.06 QUALITY ASSURANCE

- 2 A. Items provided under this section shall be listed and labeled by UL or other Nationally  
3 Recognized Testing Laboratory (NRTL).  
4 1. Term "NRTL" shall be as defined in OSHA Regulation 1910.7.  
5 2. Terms "listed" and "labeled" shall be as defined in National Electric Code, Article 100.  
6 B. Regulatory Requirements:  
7 1. National Electric Code: Components and installation shall comply with NFPA 70.  
8 2. Comply with ANSI C2, "National Electrical Safety Code".  
9 C. Coordinate fixtures mounting hardware and trim with ceiling tile.

10 1.07 WARRANTY

- 11 A. Requirements:  
12 1. Special Project Warranty Period (Where called for herein.): 10 years, beginning on date of  
13 Substantial Completion. Full warranty shall apply for first year of period, and prorata warranty  
14 for last 9 years.  
15 2. Protection of Metal from Corrosion: Warranty against perforation or erosion of finish due to  
16 weathering.  
17 3. Color Retention: Warranty against fading, staining, chalking due to effects of weather and  
18 solar radiation.

19 PART 2 - PRODUCTS

20 2.01 FIXTURES, GENERAL

- 21 A. Comply with requirements specified in Articles below and lighting fixture schedule.

22 2.02 FIXTURE COMPONENTS, GENERAL

- 23 A. Metal Parts: Free from burrs, sharp corners, and edges.  
24 B. Sheet Metal Components: Steel, except as indicated. Form and support components to  
25 prevent warping and sagging.  
26 C. Doors, Frames, and Other Internal Access: Smooth operating and free from light leakage  
27 under operating conditions. Arrange to permit relamping without use of tools. Arrange doors,  
28 frames, lenses, diffusers, and other pieces to prevent accidental falling during relamping and  
29 when secured in operating position.  
30 D. Reflecting Surfaces: Minimum reflectances as follows, except as otherwise indicated:  
31 1. White surfaces: 85%.  
32 2. Specular Surfaces: 83%.  
33 3. Diffusing Specular Surfaces: 75%.  
34 4. Laminated Silver Metallized Film: 90%.  
35 E. Exterior Housings: Rigidly formed, weather- and light-tight enclosures that will not warp, sag,  
36 or deform in use. Provide filter/breather for enclosed fixtures.  
37 F. Exterior Exposed Hardware Material: Stainless steel.  
38

- G. Lenses, Diffusers, Covers, and Globes: 100% virgin acrylic plastic or water white, annealed crystal glass except as indicated.
  - 1. Plastic: Highly resistant to yellowing and other changes due to aging, exposure to heat and UV radiation.
  - 2. Lens Thickness: 0.125 inches, minimum.
- H. Photoelectric Relay: UL 773.
  - 1. Contact Relays: Single-throw, arranged to fail in the "on" position and factory set to turn light unit on at 1.5 to 3 foot-candles and off at 4.5 to 10 foot-candles with 15 seconds minimum time delay.
  - 2. Relay Mounting: In fixture housing.

2.03 SUSPENDED FIXTURE SUPPORT COMPONENTS

- A. Single-Stem Hangers: 1/2-inch steel tubing with swivel ball fitting and ceiling canopy. Finish same as fixture.
- B. Twin-Stem Hangers: Two, 1/2-inch steel tubes with single canopy arranged to mount single fixture. Finish same as fixture.
- C. Rod Hangers: 3/16-inch diameter cadmium plated, threaded steel rod.
- D. Hook Hanger: Integrated assembly matched to fixture and line voltage and equipped with threaded attachment, cord, and locking-type plug.

2.04 LED Luminaires

- A. LED Luminaires shall meet all DesignLights Consortium® (DesignLights.org) Product Qualification Criteria. This does not require that the luminaire be listed on the DesignLights Consortium's® Qualified Products List, but they must meet the Product Qualification Criteria. The technical requirements that the luminaire shall meet for each Application Category are:
  - 1. Minimum Light Output.
  - 2. Zonal Lumen Requirements.
  - 3. Minimum Luminaire Efficacy.
  - 4. Minimum CRI.
  - 5. L70 Lumen Maintenance.
  - 6. Minimum Luminaire Warranty of 5 years (not pro-rated) to include LED driver and all LED components.

*Additional requirements:*

- B. Color Temperature of 3000K-5000K for interior fixtures as listed in the Light Fixture Schedule on the plans. The color temperature of exterior LED fixtures should not exceed 4100K (nominal).
- C. Color Consistency: LED manufacturer shall use a maximum 3-step MacAdam Ellipse binning process to achieve consistent fixture-to-fixture color for interior fixtures. Exterior fixtures shall use a maximum 5-step MacAdam Ellipse binning process.
- D. Glare Control: Exterior fixtures shall meet DesignLights Consortium's® criteria for Zonal Lumen Distribution requirements or Backlight-Uplight-Glare (BUG) standards for exterior fixtures.
- E. Luminaire shall be mercury-free, lead-free, and RoHS compliant.
- F. Luminaire shall comply with FCC 47 CFR part 15 non-consumer RFI/EMI standards.
- G. Light output of the LED system shall be measured using the absolute photometry method following IES LM-79 and IES LM-80 requirements and guidelines.
- H. Luminaire shall maintain 70% lumen output (L70) for a minimum of 50,000 hours.



- 1 I. Driver shall have a rated life of 50,000 hours, minimum.
- 2 J. Lumen output shall not depreciate more than 20% after 10,000 hours of use.
- 3 K. Driver and LEDs shall be furnished from a single manufacturer to ensure compatibility.
- 4 L. Luminaire Color Rendering Index (CRI) shall be a minimum of 80 for interior fixtures, and a  
5 minimum of 70 for exterior fixtures.
- 6 M. LED fixture shall be thermally designed as to not exceed the maximum junction temperature  
7 of the LED for the ambient temperature of the location the fixture is to be installed. Rated case  
8 temperature shall be suitable for operation in the ambient temperatures typically found for the  
9 intended installation. Exterior luminaires to operate in ambient temperatures of -20°F to 122°F  
10 (-29°C to 50°C).
- 11 N. LED driver shall have a minimum power factor (pf) of 0.9 and a maximum crest factor (cf) of  
12 1.5 at full input power and across specified voltage range.
- 13 O. Luminaire shall operate normally for input voltage fluctuations of plus or minus 10 percent.
- 14 P. Luminaire shall have a maximum Total Harmonic Distortion (THD) of 20% at full input  
15 power and across specified voltage range.
- 16 Q. Wiring connections to LED drivers shall utilize polarized quick-disconnects for field  
17 maintenance.
- 18 R. All connections to luminaires shall be reverse polarity protected and provide high voltage  
19 protection in the event connections are reversed or shorted during the installation process.
- 20 S. Fuse Protections: All luminaires shall have built-in fuse protection. All power supply outputs  
21 shall be either fuse protected or be Polymeric Positive Temperature Coefficient (PTC)-  
22 protected as per Class 2 UL listing.
- 23 T. All luminaires shall be provided with knockouts for conduit connections.
- 24 U. The LED lighting fixture shall carry a limited 5-year warranty minimum for LED light  
25 engine(s)/board array, and driver(s).
- 26 V. Provide all of the following data on submittals:
- 27 1. Delivered lumens
- 28 2. Input watts
- 29 3. Efficacy
- 30 4. Color rendering index.

31  
32 *Emergency LED Fixture Compatibility with Inverters:*

- 33 W. Emergency Inverters shall be sine-wave type or have written confirmation from the luminaire  
34 manufacturer that the fixture will function with a square-wave inverter.

35  
36 *Dimming:*

- 37 X. LED driver shall be compatible with dimming controls where dimming is indicated on the  
38 plans. Dimmable drivers shall use Dimming Constant Current (DCC) or Pulse Width  
39 Modulation (PWM) operation.
- 40 Y. LED fixtures shall dim to (20%, 15%, 10%, 5%, or 0.1%) as specified in the Light Fixture  
41 Schedule on the plans without visible flicker or “popcorn effect”. “Popcorn effect” is defined  
42 as the fixture being on a pre-set dimmed level (less than 100%) and going to 100% prior to  
43 returning to the pre-set level when power is returned to the fixture.

44

45 2.05 EXIT SIGNS

- 1           A.     Conform to UL 924.
- 2           1.     Sign Colors: Conform to local code.

3       2.06 EMERGENCY LIGHTING UNITS

- 4           A.     Conform to UL 924. Provide self-contained units with following features and additional
- 5                 characteristics as indicated.
- 6           1.     Battery: Sealed, maintenance-free, lead-acid type with 10-year nominal life minimum, and
- 7                 special project warranty.
- 8           2.     Charger: Minimum 2-rate, fully-automatic, solid-state type, with sealed transfer relay.
- 9           3.     Operation: Relay automatically turns lamp on when supply circuit voltage drops to 80% of
- 10                nominal or below. Lamp automatically disconnects from battery when voltage approaches
- 11                deep-discharge level. Relay disconnects lamps and battery automatically recharges and floats
- 12                on trickle charge when normal voltage is restored.
- 13           4.     Time-Delay Relay: Provide time-delay relay in emergency lighting unit control circuit
- 14                arranged to hold unit "on" for fixed interval after restoration of power from an outage. Provide
- 15                adequate time delay to permit HID lamps to restrike and develop output.
- 16           5.     Wire Guard: Where indicated, provide heavy chrome plated wire guard arranged to protect
- 17                lamp heads or fixtures.

18       2.07 LAMPS

- 19           A.     Conform to ANSI C78 series applicable to each type of lamp.

20       2.08 FINISH

- 21           A.     Steel Parts: Manufacturer's standard finish applied over corrosion-resistant primer, free of
- 22                 streaks, runs, holidays, stains, blisters, and defects. Remove fixtures showing evidence of
- 23                 corrosion during project warranty period and replace with new fixtures.
- 24           B.     Other Parts: Manufacturer's standard finish.
- 25           C.     Verify and provide light fixture finishes as selected by ARCHITECT for all light fixture types.
- 26                 Include colored finish selection tables with product submittals. Upon request submit actual
- 27                 material finish swatches for A/E review.

28       PART 3 - EXECUTION

29       3.01 INSTALLATION

- 30           A.     Setting and Securing: Set units plumb, square, and level with ceiling and walls, and secure
- 31                 according to manufacturer's printed instructions and approved submittals.
- 32           B.     Support For Recessed and Semi recessed Fixtures: Units may be supported from suspended
- 33                 ceiling support system. Install ceiling system support rods or wires at minimum of four rods
- 34                 or wires per fixture located not more than 6 inches from fixture corners.
- 35           1.     Fixtures Smaller Than Ceiling Grid: Install minimum of four rods or wires for each fixture
- 36                 and locate at corner of ceiling grid where fixture is located. Do not support fixtures by ceiling
- 37                 acoustical panels.
- 38           2.     Fixtures of Sizes Less Than Ceiling Grid: Center in acoustical panel. Support fixtures
- 39                 independently with at least two 3/4-inch metal channels spanning and secured to ceiling tees.
- 40           3.     Install support clips for recessed fixtures, securely fastened to ceiling grid members, at or near
- 41                 each fixture corners.
- 42           C.     Support for Suspended Fixtures: Brace pendants and rods that are 4 feet long or longer to
- 43                 limit swinging. Support stem mounted single-unit suspended fluorescent fixtures with twin-
- 44                 stem hangers. For continuous rows, use tubing or stem for wiring at one point and tubing or
- 45                 rod for suspension for each unit length of chassis, including one at each end.

1 D. Lamping: Lamp units according to manufacturer's instructions.

2 3.02 CONCRETE FOUNDATIONS

3 A. Construct concrete foundations with 3,000-pound, 28-day concrete conforming to  
4 requirements of Division 3. Comply with details and manufacturer's recommendations for  
5 reinforcing, anchor bolts, nuts, and washers.

6 3.03 GROUNDING

7 A. Ground fixtures and metal poles according to Section 26 05 11.

8 1. Poles: Install 10-foot driven ground rod at each pole.

9 2. Nonmetallic Poles: Ground metallic components of lighting unit and foundations.  
10 Connect fixtures to grounding system with No. 6 AWG conductor.

11 3.04 FIELD QUALITY CONTROL

12 A. Inspect each installed fixture for damage. Replace damaged fixtures and components.

13 B. Give 7-day notice of dates and times for field tests.

14 C. Verify normal operation of each fixture after fixtures have been installed and circuits have  
15 been energized with normal power source.

16 D. Interrupt electrical energy to demonstrate proper operation of emergency lighting installation.

17 a. Duration of supply.

18 b. Low battery voltage shut-down.

19 c. Normal transfer to battery source and retransfer to normal.

20 d. Low supply voltage transfer.

21 E. Replace or repair malfunctioning fixtures and components, then retest. Repeat procedure until  
22 units operate properly.

23 3.05 ADJUSTING AND CLEANING

24 A. Clean fixtures upon completion of installation. Use methods and materials recommended by  
25 manufacturer.

26 B. Adjust aimable fixtures to provide required light intensities.

27 END OF SECTION 26 51 13

Page Intentionally Left Blank

SECTION 27 10 00

TELECOMMUNICATIONS DISTRIBUTION SYSTEM

PART 1 - GENERAL

1.01 SCOPE

- A. The basic scope of this project is as follows:
  - 1. Provide new cables and patch panels for new outlets in the project area..
  - 2. Provide all certification and testing of the equipment and cabling as required.
- B. Section Includes: Equipment, materials, labor, and services to provide telephone and data distribution system including, but not limited to:
  - 1. Raceway and boxes
  - 2. Telephone and data cabling terminations
  - 3. Telecommunications outlets
  - 4. Terminal blocks/cross-connect systems
  - 5. System testing
  - 6. Documentation and submissions
- C. Provide all equipment, materials, labor, and services, not specifically mentioned or shown, which may be necessary to complete or perfect all parts of the installation. Ensure that they are in compliance with requirements stated or reasonably inferred by the contract documents.
- D. Work not included:
  - 1. The following work will be done by others:
    - a. Off-site services.
    - b. Providing data concentrators, hubs, servers, computers, and other active devices.

1.02 REFERENCES

- A. Design, manufacture, test, and install telecommunications cabling networks per manufacturer's requirements and in accordance with NFPA-70 (National Electrical Code®), state codes, local codes, requirements of authorities having jurisdiction, and particularly the following standards:
  - 1. ANSI/NECA/BICSI-568 -- Standard for Installing Commercial Building Telecommunications Cabling
  - 2. ANSI/TIA/EIA Standards
    - a. ANSI/TIA/EIA-568-B.1 -- Commercial Building Telecommunications Cabling Standard, Part 1: General Requirements
    - b. ANSI/TIA/EIA-568-B.2 -- Commercial Building Telecommunications Cabling Standard, Part 2: Balanced Twisted Pair Cabling Components
    - c. ANSI/TIA/EIA-568-B.3 -- Optical Fiber Cabling Components Standard
    - d. ANSI/TIA/EIA-569-A -- Commercial Building Standard for Telecommunications Pathways and Spaces
    - e. ANSI/TIA/EIA-606(A) -- The Administration Standard for the Telecommunications Infrastructure of Commercial Buildings
    - f. ANSI/TIA/EIA-607(A) -- Commercial Building Grounding and Bonding Requirements for Telecommunications
    - g. ANSI/TIA/EIA-526-7 -- Measurement of Optical Power Loss of Installed Single-Mode Fiber Cable Plant
    - h. ANSI/TIA/EIA-526-14A -- Measurement of Optical Power Loss of Installed Multimode Fiber Cable Plant

- 1                   i.     ANSI/TIA/EIA-758(A) -- Customer-Owned Outside Plant Telecommunications  
2                   Cabling Standard
- 3     B.     Install cabling in accordance with the most recent edition of BICSI® publications:
- 4             1.     BICSI -- Telecommunications Distribution Methods Manual
- 5             2.     BICSI -- Cabling Installation Manual
- 6             3.     BICSI -- LAN Design Manual
- 7             4.     BICSI -- Customer-Owned Outside Plant Design Manual
- 8     C.     Federal, state, and local codes, rules, regulations, and ordinances governing the work, are as fully part  
9     of the specifications as if herein repeated or hereto attached. If the contractor should note items in the  
10    drawings or the specifications, construction of which would be code violations, promptly call them to  
11    the attention of the owner's representative in writing. Where the requirements of other sections of the  
12    specifications are more stringent than applicable codes, rules, regulations, and ordinances, the  
13    specifications shall apply.

14    1.03    PERMITS, FEES, AND CERTIFICATES OF APPROVAL

- 15           A.     As prerequisite to final acceptance, supply to the owner certificates of inspection from an inspection  
16           agency acceptable to the owner and approved by local municipality and utility company serving the  
17           project.

18    1.04    SYSTEM DESCRIPTION

- 19           A.     Telecommunications cabling system generally consists of one telecommunications outlet in each  
20           workstation, wall telephones in common and mechanical areas and telecommunications rooms (TRs)  
21           located on each floor.
- 22           B.     The typical work area consists of a single-gang plate with three standards compliant work area outlets.
- 23                 1.     Each work area outlet consists of one (1) four-pair data Category 6 cable or above, installed  
24                 from work area outlet to the TR. Terminate data cables on rack mounted modular patch panels  
25                 located in the appropriate TR.

26    1.05    SUBMITTALS

- 27           A.     Submit to the engineer/designer shop drawings, product data (including cut sheets and catalog  
28           information), and samples required by the contract documents. Submit shop drawings, product data,  
29           and samples with such promptness and in such sequence as to cause no delay in the work or in the  
30           activities of separate contractors. The engineer/designer will indicate approval of shop drawings,  
31           product data, and samples submitted to the engineer by stamping such submittals "APPROVED" with  
32           a stamp. Submitted shop drawings shall be initialed or signed by the contractor, showing the date and  
33           the contractor's legitimate firm name.
- 34                 1.     By submitting shop drawings, product data, and samples, the contractor represents that he or  
35                 she has carefully reviewed and verified materials, quantities, field measurements, and field  
36                 construction criteria related thereto. It also represents that the contractor has checked,  
37                 coordinated, and verified that information contained within shop drawings, product data, and  
38                 samples conform to the requirements of the work and of the contract documents. The  
39                 engineer/designer remains responsible for the design concept expressed in the contract  
40                 documents as defined herein.
- 41                 2.     The engineer's/designer's approval of shop drawings, product data, and samples submitted by  
42                 the contractor shall not relieve the contractor of responsibility for deviations from requirements  
43                 of the contract documents, unless the contractor has specifically informed the  
44                 engineer/designer in writing of such deviation at time of submittal, and the engineer/designer  
45                 has given written approval of the specific deviation. The contractor shall continue to be  
46                 responsible for deviations from requirements of the contract documents not specifically noted  
47                 by the contractor in writing, and specifically approved by the engineer in writing.
- 48

- 1                   3.    The engineer's/designer's approval of shop drawings, product data, and samples shall not  
2                   relieve the contractor of responsibility for errors or omissions in such shop drawings, product  
3                   data, and samples.
- 4                   4.    The engineer's/designer's review and approval, or other appropriate action upon shop  
5                   drawings, product data, and samples, is for the limited purpose of checking for conformance  
6                   with information given and design concept expressed in the contract documents. The  
7                   engineer's/designer's review of such submittals is not conducted for the purpose of  
8                   determining accuracy and completeness of other details such as dimensions and quantities, or  
9                   for substantiating instructions for installation or performance of equipment or systems, all of  
10                  which remain the responsibility of the contractor as required by the contract documents. The  
11                  review shall not constitute approval of safety precautions or of construction means, methods,  
12                  techniques, sequences, or procedures. The engineer's/designer's approval of a specific item  
13                  shall not indicate approval of an assembly of which the item is a component.
- 14                B.    Perform no portion of the work requiring submittal and review of shop drawings, product data, or  
15                samples, until the engineer/designer has approved the respective submittal. Such work shall be in  
16                accordance with approved submittals.
- 17                C.    Submit shop drawings, product data, and samples as a complete set within thirty (30) days of award of  
18                contract.
- 19                    1.    For initial submission and for resubmission required for approval, submit four (4) copies of  
20                    each item. The engineer/designer will only return two copies. Make reproductions as required  
21                    for your use and distribution to subcontractors.
- 22                    2.    Illegible submittals will not be checked by the engineer.
- 23                D.    General: Submit the following:
- 24                    1.    Bill of materials, noting long lead time items
- 25                    2.    Optical loss budget calculations for each optical fiber run
- 26                    3.    Project schedule including all major work components that materially affect any other work on  
27                    the project
- 28                E.    Shop drawings: Submit the following:
- 29                    1.    Backbone (riser) diagrams.
- 30                    2.    System block diagram, indicating interconnection between system components and  
31                    subsystems.
- 32                    3.    Interface requirements, including connector types and pin-outs, to external systems and  
33                    systems or components not supplied by the contractor.
- 34                    4.    Fabrication drawings for custom-built equipment.
- 35                F.    Product Data -- Provide catalog cut sheets and information for the following:
- 36                    1.    Wire and cable
- 37                    2.    Outlets, jacks, faceplates, and connectors
- 38                    3.    All metallic and nonmetallic raceways, including surface raceways, outlet boxes, and fittings
- 39                    4.    Terminal blocks and patch panels
- 40                G.    Project record drawings:
- 41                    1.    Submit project record drawings at conclusion of the project and include:
- 42                          a.    Approved shop drawings
- 43                          b.    Plan drawings indicating locations and identification of work area outlets, nodes,  
44                          telecommunications rooms (TRs), and backbone (riser) cable runs
- 45                          c.    Telecommunications rooms (TRs) and equipment room (ER and/or MC) termination  
46                          detail sheets.
- 47                          d.    Cross-connect schedules including entrance point, main cross-connects, intermediate  
48                          cross-connects, and horizontal cross-connects.

- 1 e. Labeling and administration documentation.
- 2 f. Warranty documents for equipment.
- 3 g. Copper certification test result printouts and diskettes.
- 4 (a.) Optical fiber power meter/light source test results.

5 1.06 QUALITY ASSURANCE

- 6 A. The contractor shall have worked satisfactorily for a minimum of five (5) years on systems of this  
7 type and size.
- 8 B. Upon request by the engineer/designer, furnish a list of references with specific information regarding  
9 type of project and involvement in providing of equipment and systems.
- 10 C. Equipment and materials of the type for which there are independent standard testing requirements,  
11 listings, and labels, shall be listed and labeled by the independent testing laboratory.
- 12 D. Where equipment and materials have industry certification, labels, or standards (i.e., NEMA -  
13 National Electrical Manufacturers Association), this equipment shall be labeled as certified or  
14 complying with standards.
- 15 E. Material and equipment shall be new, and conform to grade, quality, and standards specified.  
16 Equipment and materials of the same type shall be a product of the same manufacturer throughout.
- 17 F. Subcontractors shall assume all rights and obligations toward the contractor that the contractor  
18 assumes toward the owner and engineer/designer.

19 1.07 WARRANTY

- 20 A. Unless otherwise specified, unconditionally guarantee in writing the materials, equipment, and  
21 workmanship for a period of not less than fifteen (15) years from date of acceptance by the owner.  
22 The owner shall deem acceptance as beneficial use.
- 23 B. Transfer manufacturer's warranties to the owner in addition to the General System Guarantee. Submit  
24 these warranties on each item in list form with shop drawings. Detail specific parts within equipment  
25 that are subject to separate conditional warranty. Warranty proprietary equipment and systems  
26 involved in this contract during the guarantee period. Final payment shall not relieve you of these  
27 obligations.

28 1.08 DELIVERY, STORAGE, AND HANDLING

- 29 A. Protect equipment during transit, storage, and handling to prevent damage, theft, soiling, and  
30 misalignment. Coordinate with the owner for secure storage of equipment and materials. Do not  
31 store equipment where conditions fall outside manufacturer's recommendations for environmental  
32 conditions. Do not install damaged equipment; remove from site and replace damaged equipment  
33 with new equipment.

34 1.09 SEQUENCE AND SCHEDULING

- 35 A. Submit schedule for installation of equipment and cabling. Indicate delivery, installation, and testing  
36 for conformance to specific job completion dates. As a minimum, dates are to be provided for bid  
37 award, installation start date, completion of station cabling, completion of riser cabling, completion of  
38 testing and labeling, cutover, completion of the final punch list, start of demolition, owner acceptance,  
39 and demolition completion.

40 1.10 USE OF THE SITE

- 41 A. Perform all work with the building occupied
- 42 B. Access to building wherein the work is performed shall be as directed by the owner.
- 43



1 PART 2 - PRODUCTS

2 2.01 MANUFACTURERS

3 A. Hubbell, Ortronics, Panduit

4 1. Or any other approved equivalent manufacturer that meets the performance requirements of  
5 this specification. Category 6 performance is standard.

6 2. Contractor shall be a certified installer.

7 B. Berk-Tek

8 C. Belden

9 D. Mohawk

10 E. Commscope

11 F. Superior Essex

12 G. Optical Cable Corporation

13 2.02 FABRICATION

14 A. Fabricate custom-made equipment with careful consideration given to aesthetic, technical, and  
15 functional aspects of equipment and its installation.

16 2.03 SUITABILITY

17 A. Provide products that are suitable for intended use, including, but not limited to environmental,  
18 regulatory, and electrical.

19 2.04 STATION CABLE

20 A. VOICE TELECOMMUNICATIONS STATION CABLE

21 1. Solid copper, 24 AWG, 100 W balanced twisted-pair (UTP) Category 6 cables with four  
22 individually twisted-pairs, which meet or exceed the mechanical and transmission performance  
23 specifications in ANSI/TIA/EIA-568-B.2 up to 250 MHz.

24 a. Listed Type CMP (as required in the NEC 2011).

25 B. DATA STATION CABLE (Copper)

26 1. Solid copper, 24 AWG, 100 W balanced twisted-pair (UTP) Category 6 cables with four  
27 individually twisted-pairs, which meet or exceed the mechanical and transmission performance  
28 specifications in ANSI/TIA/EIA-568-B.2 up to 250 MHz.

29 a. Listed Type CMP (as required in the NEC 2011).

30 2.05 WORK AREA OUTLETS

31 A. VOICE/DATA WORK AREA OUTLETS (Copper only)

32 1. Single-gang stainless steel mounting plate with four (4) openings containing the following  
33 devices:

34 a. Voice Outlet - 8-pin modular, Category 6, unkeyed, white, pinned to T568A standards.

35 b. Two Data Outlets - 8-pin modular, Category 6, unkeyed, blue, pinned to T568A  
36 standards.

37 2. The device color of outlets and jacket color for cabling that will be used on the project shall be  
38 coordinated with the Dane County Information Technology (IT) Department prior to the  
39 beginning of any work. It is intended that the Dane County standard being maintained.

40 B. WALL VOICE OUTLETS

41 1. Single-gang stainless steel faceplate with six-conductor jack and wall telephone mounting lugs

1 C. DATA ONLY WORK AREA OUTLET  
2 1. Single-gang faceplate with 8-pin modular, category 6, unkeyed, blue data jack, pinned to  
3 T568A standards

4 D. VOICE ONLY WORK AREA OUTLET  
5 1. Single-gang faceplate with 8-pin modular, category 6, unkeyed, white telephone jack, pinned  
6 to T568A standards

7 2.06 PATCH PANELS

8 A. 19 in. rack mountable, 24-port 8-pin modular to insulation displacement connector (IDC) meeting  
9 Category 6 performance standards and pinned to T568 A standards. Typical examples of IDC  
10 connections are the 110, BIX, and Krone.

11 2.07 EQUIPMENT RACKS

12 A. Racks are existing.

13 PART 3 - EXECUTION

14 3.01 PRE-INSTALLATION SITE SURVEY

15 A. Prior to start of systems installation, meet at the project site with the owner's representative and  
16 representatives of trades performing related work to coordinate efforts. Review areas of potential  
17 interference and resolve conflicts before proceeding with the work. Facilitation with the General  
18 Contractor will be necessary to plan the crucial scheduled completions of the equipment room and  
19 telecommunications closets.

20 B. Examine areas and conditions under which the system is to be installed. Do not proceed with the  
21 work until satisfactory conditions have been achieved.

22 C. The contractor shall be responsible for meeting with the Owner's (Dane County) Information  
23 Technology staff prior to the start of any installation to coordinate the work to be installed as part of  
24 this project. It is the design intent to maintain any cabling or installation standards that are currently  
25 in use by Dane County.

26 1. Failure to perform this meeting may cause work to be removed and reinstalled if not deemed  
27 acceptable by Dane County.

28 3.02 HANDLING AND PROTECTION OF EQUIPMENT AND MATERIALS

29 A. Be responsible for safekeeping of your own and your subcontractors' property, such as equipment and  
30 materials, on the job site. The owner assumes no responsibility for protection of above named  
31 property against fire, theft, and environmental conditions.

32 3.03 PROTECTION OF OWNER'S FACILITIES

33 A. Effectively protect the owner's facilities, equipment, and materials from dust, dirt, and damage during  
34 construction.

35 B. Remove protection at completion of the work.

36 3.04 INSTALLATION

37 A. Receive, check, unload, handle, store, and adequately protect equipment and materials to be installed  
38 as part of the contract. Store in areas as directed by the owner's representative. Include delivery,  
39 unloading, setting in place, fastening to walls, floors, ceilings, or other structures where required,  
40 interconnecting wiring of system components, equipment alignment and adjustment, and other related  
41 work whether or not expressly defined herein.

42 B. Install materials and equipment in accordance with applicable standards, codes, requirements, and  
43 recommendations of national, state, and local authorities having jurisdiction, and National Electrical

- 1 Code® (NEC) and with manufacturer's printed instructions.
- 2 C. Adhere to manufacturer's published specifications for pulling tension, minimum bend radii, and  
3 sidewall pressure when installing cables.
- 4 1. Where manufacturer does not provide bending radii information, minimum-bending radius  
5 shall be 15 times cable diameter. Arrange and mount equipment and materials in a manner  
6 acceptable to the engineer and the owner.
- 7 D. Penetrations through floor and fire-rated walls shall utilize intermediate metallic conduit (IMC) or  
8 galvanized rigid conduit (GRC) sleeves and shall be fire stopped after installation and testing,  
9 utilizing a firestopping assembly approved for that application.
- 10 E. Install station cabling to the nearest telecommunications room (TR), unless otherwise noted.
- 11 F. Installation shall conform to the following basic guidelines:
- 12 1. Use of approved wire, cable, and wiring devices  
13 2. Neat and uncluttered wire termination
- 14 G. Attach cables to permanent structure with suitable attachments at intervals of 48 to 60 inches.  
15 Support cables installed above removable ceilings.
- 16 H. Install adequate support structures for 10 foot of service slack at each TR.
- 17 I. Support riser cables every three (3) floors and at top of run with cable grips.
- 18 1. Limit number of four-pair data riser cables per grip to fifty (50)
- 19 J. Install cables in one continuous piece. Splices shall not be allowed except as indicated on the  
20 drawings or noted below:
- 21 K. Provide overvoltage protection on both ends of cabling exposed to lightning or accidental contact with  
22 power conductors.

23 3.05 GROUNDING

- 24 A. Grounding shall conform to ANSI/TIA/EIA 607(A) - Commercial Building Grounding and Bonding  
25 Requirements for Telecommunications, National Electrical Code®, ANSI/NECA/BICSI-568 and  
26 manufacturer's grounding requirements as minimum.
- 27 B. Bond and ground equipment racks, housings, messenger cables, and raceways.
- 28 C. Connect cabinets, racks, and frames to single-point ground which is connected to building ground  
29 system via #6 AWG green insulated copper grounding conductor.

30 3.06 LABELING

- 31 A. Labeling shall conform to ANSI/TIA/EIA-606(A) standards. In addition, provide the following:
- 32 1. Label each outlet with permanent self-adhesive label with minimum 3/16 in. high characters.  
33 2. Label each cable with permanent self-adhesive label with minimum, 1/8 in. high characters, in  
34 the following locations:
- 35 a. Inside receptacle box at the work area.  
36 b. Behind the communication closet patch panel or punch block.  
37 c. Use labels on face of data patch panels. Provide facility assignment records in a  
38 protective cover at each telecommunications closet location that is specific to the  
39 facilities terminated therein.  
40 d. Use color-coded labels for each termination field that conforms to ANSI/TIA/EIA-  
41 606(A) standard color codes for termination blocks.  
42 e. Mount termination blocks on color-coded backboards.  
43 f. Labels shall be machine-printed. Hand-lettered labels shall not be acceptable.  
44 g. Label cables, outlets, patch panels, and punch blocks with room number in which

outlet is located, followed by a single letter suffix to indicate particular outlet within room, i.e., S2107A, S2107B. Indicate riser cables by an R then pair or cable number.

h. Mark up floor plans showing outlet locations, type, and cable marking of cables. Turn these drawings over to the owner two (2) weeks prior to move in to allow the owner's personnel to connect and test owner-provided equipment in a timely fashion.

i. Three (3) sets of as-built drawing shall be delivered to the owner within four (4) weeks of acceptance of project by the owner. A set of as-built drawings shall be provided to the owner in magnetic media form (3.5" floppy disks) and utilizing CAD software that is acceptable to the owner. The magnetic media shall be delivered to the owner within six (6) weeks of acceptance of project by owner.

3.07 TESTING

A. Testing shall conform to ANSI/TIA/EIA-568-B.1 standard. Testing shall be accomplished using level IIe or higher field testers.

B. Test each pair and shield of each cable for opens, shorts, grounds, and pair reversal. Correct grounded, and reversed pairs. Examine open and shorted pairs to determine if problem is caused by improper termination. If termination is proper, tag bad pairs at both ends and note on termination sheets.

1. Perform testing of copper cables with tester meeting ANSI/TIA/EIA-568-B.1 requirements.

**Category 6 Test Parameters:**

Frequency Mhz	Category 6 Cable Permanent Link Test					
	TIA/EIA 568B.2-1 Insertion Loss Attenuation Max. dB	TIA/EIA 568B.2-1 NEXT Worst Pair to Pair dB	TIA/EIA 568B.2-1 PSNEXT Worst Case Loss dB	TIA/EIA 568B.2-1 ELFEXT Worst Pair to Pair Loss DB	TIA/EIA 568B.2-1 PSELFEXT Loss dB	TIA/EIA 568B.2-1 Return Loss dB
	1.00	1.9	65.0	62.0	64.2	61.2
4.00	3.5	64.1	61.8	52.1	49.1	21.0
8.00	5.0	59.4	57.0	46.1	43.1	21.0
10.00	5.5	57.8	55.5	44.2	41.2	21.0
16.00	7.0	54.6	52.2	40.1	37.1	20.0
20.00	7.9	53.1	50.7	38.2	35.2	19.5
25.00	8.9	51.5	49.1	36.2	33.2	19.0
31.25	10.0	50.0	47.5	34.3	31.3	18.5
62.50	14.4	45.1	42.7	28.3	25.3	16.0
100.00	18.6	41.8	39.3	24.2	21.2	14.0
200.00	27.4	36.9	34.3	18.2	15.2	11.0
250.00	31.1	35.3	32.7	16.2	13.2	10.0

C. Propagation Delay

1. The maximum propagation delay determined in accordance with the ANSI/TIA/EIA –568B.2 for a Permanent Link configuration shall be less than 498-ns measured at 10MHz. (Note: In determining the permanent link propagation delay, the propagation delay contribution of connecting hardware is assumed to not exceed 2.5 ns from 1 MHz to 250MHz).

D. Delay Skew

1. For all frequencies from 1 MHz to 250 MHz, Category 6 cable propagation delay skew shall not exceed 44ns/100m at 20 degrees C, 40 degrees C, and 60 degrees C. In addition, the propagation delay skew between all pairs shall not vary more than +/- 10ns from the measured value at 20 degrees C when measured at 40 degrees C and 60 degrees C. Compliance shall be determined using a minimum 100m of cable.

E. In order to establish testing baselines, cable samples of known length and of the cable type and lot

1 installed shall be tested. The cable may be terminated with an 8-position Category 6 Modular plug (8-  
2 pin) to facilitate testing. Net Propagation Velocity (NPV) and nominal attenuation values shall be  
3 calculated based on this test and be utilized during the testing of the installed cable plant. This  
4 requirement can be waived if NPV data is available from the cable manufacturer for the exact cable  
5 type under test.

- 6 F. In the event results of the tests are not satisfactory, the Contractor shall make adjustments,  
7 replacement and changes as are necessary, and shall then repeat the test or tests which disclosed faulty  
8 or defective material, equipment or installation method, and shall make additional tests as the  
9 Engineer deems necessary at no additional expense to the project or user agency.
- 10 G. Where any portion of system does not meet the specifications, correct deviation and repeat applicable  
11 testing at no additional cost to the owner.

12 3.08 FIELD QUALITY CONTROL

- 13 A. Employ job superintendent or project manager during the course of the installation to provide  
14 coordination of work of this specification and of other trades and provide technical information when  
15 requested by other trades. This person shall maintain current RCDD® (Registered Communications  
16 Distribution Designer) registration and shall be responsible for quality control during installation,  
17 equipment set-up, and testing.
- 18 B. At least 30 percent of installation personnel shall be BICSI Registered Telecommunications Installers.  
19 Of that number, at least 15 percent shall be registered at the Technician Level, at least 40 percent shall  
20 be registered at the Installer Level 2, and the balance shall be registered at the Installer Level 1.
- 21 C. Installation personnel shall meet manufacturer's training and education requirements for  
22 implementation of extended warranty program.

23  
24 END OF SECTION 27 10 00  
25  
26

Page Intentionally Left Blank

SECTION 28 31 00  
FIRE ALARM SYSTEM

PART 1 - GENERAL

1.1 RELATED DOCUMENTS

- A. Conditions of the Contract and portions of Division One of this Project Manual apply to this Section as though repeated herein.

1.2 SYSTEM DESCRIPTION

- A. Extend the existing Cerberus Pyrotronics, UL Listed intelligent analog addressable voice evacuation system.
- B. Materials can be obtained from Siemens in Milwaukee. Contact Mike Terry at 414-788-1733.

1.3 BUILDING CODES and STANDARDS

- A. National Fire Protection Association (NFPA):
  - 1. NFPA-70 National Electrical Code (NEC)
  - 2. NFPA-72 National Fire Alarm Code
  - 3. NFPA 101 Life Safety Code
  - 4. IBC International Building Code
  - 5. IFC International Fire Code
  - 6. IMC International Mechanical Code
- B. National Electrical Manufacture's Association (NEMA)
- C. Underwriters Laboratories, Inc. (UL)
  - 1. UL-864 Control Units for Fire Protective Signaling Systems (9<sup>th</sup> Edition)
  - 2. UL-268 Smoke Detector for Fire Protective Signaling Systems
  - 3. UL-217 Smoke Detectors for Single and Multiple Station
  - 4. UL-521 Heat Detectors for Fire Protective Signaling Systems
  - 5. UL-464 Audible Signaling Appliances
  - 6. UL-1971 Visual Signaling Appliances
  - 7. UL-38 Manually Actuated Signaling Boxes
  - 8. UL-1481 Power Supplies for Fire Protective Signaling Systems
  - 9. UL 2017 Standard for General-Purpose Signaling Devices and Systems
  - 10. UL 2572 Control and Communication Units for Mass Notification Systems

## 1.4 SUBMITTALS

- A. The Contractor shall not purchase any equipment for the system specified herein until the Owner has approved the project submittals in their entirety and has returned them to the contractor. It is the responsibility of the contractor to meet the entire intent and functional performance detailed in these specifications. Approved submittals shall only allow the contractor to proceed with the installation and shall not be construed to mean that the contractor has satisfied the requirements of these specifications. The Contractor shall submit three (3) complete sets of documentation within 30 calendar days after award of purchase order.
- B. Each submittal shall include a cover letter providing a list of each variation that the submittal may have from the requirements of the Contract Documents. In addition the Contractor shall provide specific notation on each Shop Drawing, sample, catalog cut, data sheet, installation manual, etc. submitted for review and approval, of each such variation.
  - 1. Submittals shall be approved by authorities having jurisdiction prior to submitting them to the Architect.
  - 2. Shop Drawings shall be prepared by persons with the following qualifications:
    - a. Trained and certified by manufacturer in fire-alarm system design.
    - b. NICET-certified fire-alarm technician, Level IV minimum or Wisconsin registered Professional Engineer.
- C. Product Data: Product Data sheets with the printed logo or trademark of the manufacturer of all equipment. Indicated in the documentation shall be the type, size, rating, style, and catalog number for all items proposed to meet the system performance detailed in this specification. The proposed equipment shall be subject to the approval of the Owner.
- D. Shop Drawings: Include plans, elevations, sections, details, and attachments to other work.
  - 1. Comply with recommendations in the "Documentation" Section of the "Fundamentals of Fire Alarm Systems" Chapter in NFPA72.
  - 2. Include voltage drop calculations for notification appliance circuits based on manufacturer-provided panel start voltage and lump-sum method calculation. Point-to-point notification appliance circuit calculations are not acceptable.
  - 3. Include battery-size calculations. Batteries shall be upsized 25% from minimum requirements derived from calculations.
  - 4. Include performance parameters and installation details for each detector, verifying that each detector is listed for complete range of air velocity, temperature, and humidity possible when air-handling system is operating.
  - 5. Include plans, sections, and elevations of heating, ventilating, and air-conditioning ducts, drawn to scale and coordinating installation of duct smoke detectors and access to them. Show critical dimensions that relate to placement and support of sampling tubes, detector housing, and remote status and alarm indicators. Locate detectors according to manufacturer's written recommendations.
  - 6. Include voice/alarm signaling-service equipment rack or console layout, grounding schematic, amplifier power calculation, and single-line connection diagram.
  - 7. Include floor plans to indicate final outlet locations showing address of each addressable device. Show size and route of cable and conduits from end-to-end. "Home Run" indicators or other non-end-to-end wire path designations are not acceptable.



- E. Operation and Maintenance Data: For fire-alarm systems and components to be included in emergency, operation, and maintenance manuals. In addition to items specified in Division 1 Section "Operation and Maintenance Data, include the following:
1. Comply with the "Records" Section of the "Inspection, Testing and Maintenance" Chapter in NFPA72.
  2. Provide "Record of Completion Documents" according to NFPA72 article "Permanent Records" in the "Records" Section of the "Inspection, Testing and Maintenance" Chapter.
  3. Record copy of site-specific software database file, hardcopy printout and CD, with password for delivery to the owner. Proprietary system/service companies will not be acceptable.
  4. Provide "Maintenance, Inspection and Testing Records" according to NFPA72 article of the same name and include the following:
    - a. Frequency of testing of installed components.
    - b. Frequency of inspection of installed components.
    - c. Requirements and recommendations related to results of maintenance.
    - d. Manufacturer's user training manuals (hardcopy) and electronic on CD.
  5. Manufacturer's required maintenance related to system warranty requirements.
  6. Abbreviated operating instructions for mounting at fire-alarm control unit.
- F. Software and Firmware Operational Documentation:
1. CD of site-specific software database file with password, all product data sheets and AutoCAD 2016 files. Provide hard copy printout of the software program. Proprietary system/service companies will not be acceptable.
  2. Provide a list of global system settings
  3. Provide a list of the contents of each system cabinet and their settings
  4. Provide a list of all addressable devices with their addresses and settings

## 1.5 QUALITY ASSURANCE

- A. Installer Qualifications: Personnel shall be trained and certified by manufacturer for installation of units required for this Project.
- B. Installer Qualifications: Installation shall be by personnel certified by NICET as fire alarm Level II technicians.
- C. Project Manager Qualifications: Installation shall be supervised by personnel certified by NICET as fire alarm Level IV technicians.
- D. Source Limitations for Fire-Alarm System and Components: Obtain fire-alarm system from single source from single manufacturer. Components shall be compatible with, and operate as, an extension of existing system.
- E. Electrical Components, Devices, and Accessories: Listed and labeled as defined in NFPA70, by a qualified testing agency, and marked for intended location and application.
- F. NFPA Certification: Obtain certification according to NFPA72 in the form of a placard by an approved alarm company.

## 1.6 WARRANTY AND SOFTWARE SERVICE AGREEMENT

- A. The contractor shall warranty all materials, installation and workmanship for one (1) year from date of acceptance, unless otherwise specified. A copy of the manufacturers' warranty shall be provided with closeout documentation and included with the operation and installation manuals.
- B. The System Supplier shall maintain a service organization with adequate spare parts stocked within 90 miles of the installation. Any defects that render the system inoperative shall be repaired within 24 hours of the Owner notifying the contractor.

## PART 2 - PRODUCTS

### 2.1 MANUFACTURERS

- A. Cerberus Pyrotronics only to match existing fire alarm control panel.

### 2.2 SYSTEMS OPERATIONAL DESCRIPTION

- A. Maintain the current sequence of operations.

### 2.3 FIRE-ALARM CONTROL UNIT

- A. The existing fire alarm control panel was manufactured by Cerberus Pyrotronics.

### 2.4 NAC POWER SUPPLY

- A. The NAC power supply shall be independent unit that will provide power to visual strobe notification appliances. It shall be possible to configure the NAC's to follow the main panel's NAC or activate from intelligent synchronized modules. The booster NAC's must be configurable to operate independently at any one of the following rates: continuous synchronized, or 3-3-3 temporal. Fault conditions on the power supply shall not impede alarm activation of host NAC circuits or other power supplies. The NAC power supply must be able to provide concurrent power for notification devices, security devices, access control equipment and auxiliary devices such as door holders. . All the NAC Power Supplies shall be synchronized. The power supply shall support up to 24 amp hour batteries.
  - 1. Power supply shall be minimum of 10 amps and UL 864 Listed.
  - 2. Four independent 3amp NAC circuits. Each being configurable as auxiliary power.
  - 3. All circuits shall be synchronized.
  - 4. Shall be XXX.

### 2.5 INTELLIGENT ANALOG SYSTEM DETECTORS

- A. Intelligent Photoelectric Detector
  - 1. Provide intelligent analog addressable photoelectric smoke detectors at the locations shown on the drawings.
  - 2. Provide FP-11.

B. Intelligent Fixed Temperature Heat Detector

1. Provide FPT-11T.

C. Detector Base Types

1. Provide DB-11.

2.6 MANUAL FIRE-ALARM BOXES

A. General Requirements for Manual Fire-Alarm Boxes: Comply with UL38. Boxes shall be finished in red with molded, raised-letter operating instructions in contrasting color; shall show visible indication of operation; and shall be mounted on recessed outlet box. If indicated as surface mounted, provide manufacturer's surface back box.

1. Double-action mechanism requiring two actions to initiate an alarm, pull-lever type; with integral addressable module arranged to communicate manual-station status (normal, alarm, or trouble) to fire-alarm control unit.
2. The manual pull station will have an intelligent module integral of the unit.
3. Station Reset: key operated switch shall match the control panel key.
4. Manual pull stations that initiated an alarm condition by opening the unit are not acceptable.

2.7 NOTIFICATION APPLIANCES

A. All appliances shall be of the same manufacturer as the Fire Alarm Control Panel specified to insure absolute compatibility between the appliances and the control panels, and to insure that the application of the appliances are done in accordance with the single manufacturers' instructions.

B. All appliances shall be wall mounted red body and marking of FIRE and shall be UL 1971 & UL 464 listed Fire Protective Service.

C. Notification Appliances – Visual

1. Provide clear lens strobes that provide a smooth light distribution pattern field selectable candela 15 cd, 30 cd, 75 cd, and 110 cd flash output rating, UL1971 listed with in-out screw terminals shall be provided for wiring. The strobe (15, 30, 75, 110) candela rating shall be view from the side window to verify the setting. Provide synchronization to within 10 milliseconds for an indefinite period without the use of separately installed remote synch modules. The strobes shall mount to one-gang electrical box.
2. High candela clear lens strobes that provide field selectable candela 95cd, 115cd, 150cd and 177cd flash output rating, UL1971 listed with in-out screw terminals shall be provided for wiring.
3. Provide VR-MC-R.

D. Speaker/strobes

1. Provide low profile wall mounted speaker/strobes at the locations show on the drawings.
2. Low profile speakers shall mount in North American 1-gang box and protrude less than 1” from the finished wall. The work FIRE shall be prominently displayed on the housing.
3. The speakers shall provide an audible output of 85 dBA at 10 ft. when measured in reverberations room per UL-464,.
4. The speaker/strobes shall be SET-MMP-R for wall mounting.

## 2.8 INSPECTION BAR CODES

- A. Inspection bar codes shall be installed on all initiating devices, annunciators, control panels and power supplies.
- B. Inspection bar codes used by the system must utilize Code 3 of 9 or other approved format, and contain a minimum of eight (8) digits that comprise a unique serial identifier within the Web-based Reporting System. There shall be no duplication of serial numbers. Serial number shall be printed below the bar code for identification purposes.
- C. Inspection bar codes shall be limited in size to no more than 2" (5cm) in width, and 3/8" (2 cm), in height and shall include a Mylar<sup>®</sup> or other protective coating to protect the bar code from fading due to sunlight or exposure.
- D. Inspection bar codes shall be installed on each device in such a manner as to require that scanning of the bar code take place no further than 12" from the device during inspection.

## 2.9 WIRE AND CABLE

- A. Signaling Line Circuits – Network Data: Twisted pair, not less than No. 18 AWG or as recommended by the manufacturer.
- B. Signaling Line Circuits – Intelligent Loop: Non-Twisted pair, not less than No. 16 AWG or as recommended by the manufacturer.
  - 1. Circuit Integrity Cable: Provide as required to meet NFPA or Local Code requirements.
  - 2. CI Cable shall meet article 760, power limited fire alarm service.
- C. Notification Appliance Circuits
  - 1. Audio: Twisted pair, not less than No. 16 AWG or as recommended by the manufacturer.
  - 2. Visual. Non-Twisted pair, not less than No. 12 AWG or as recommended by the manufacturer.

## PART 3 - EXECUTION

### 3.1 EQUIPMENT INSTALLATION

- A. Comply with NFPA 72 and NEC Article 760 for installation of fire-alarm equipment.
- B. Equipment Mounting: Install fire-alarm control unit on finished floor with tops of cabinets not more than 72 inches above the finished floor.
- C. Connecting to Existing Equipment: Verify that existing fire-alarm system is operational before making changes or connections.
  - 1. Connect new equipment to existing control panel in existing part of the building.
  - 2. Connect new equipment to existing monitoring equipment at the supervising station.
  - 3. Expand, modify, and supplement existing equipment as necessary to extend existing functions to the new points. New components shall be capable of merging with existing configuration without degrading the performance of either system.

D. Smoke- or Heat-Detector Spacing:

1. Comply with NFPA72, "Smoke-Sensing Fire Detectors" Section in the "Initiating Devices" Chapter, for smoke-detector spacing.
2. Comply with NFPA72, "Heat-Sensing Fire Detectors" Section in the "Initiating Devices" Chapter, for heat-detector spacing.
3. Smooth ceiling spacing shall not exceed 30 feet.
4. Spacing of detectors for irregular areas, for irregular ceiling construction, and for high ceiling areas shall be determined according to Appendix A in NFPA 72.
5. HVAC: Locate detectors not closer than 3 feet from air-supply diffuser or return-air opening.
6. Lighting Fixtures: Locate detectors not closer than 12 inches from any part of a lighting fixture.

E. Notification Appliance Devices: Install between 80 and 96 inches on the wall.

F. Fire-Alarm Control Unit: Surface mounted, with tops of cabinets not more than 72 inches above the finished floor.

G. Annunciator: Install with top of panel not more than 56 inches above the finished floor.

### 3.2 CONNECTIONS

A. For fire-protection systems related to doors in fire-rated walls and partitions and to doors in smoke partitions, comply with requirements in Division 8 Section "Door Hardware." Connect hardware and devices to fire-alarm system.

1. Verify that hardware and devices are NRTL listed for use with fire-alarm system in this Section before making connections.

B. Make addressable connections with a supervised interface device to the following devices and systems. Install the interface device less than 3 feet from the device controlled. Make an addressable confirmation connection when such feedback is available at the device or system being controlled.

1. Smoke dampers in air ducts of designated air-conditioning duct systems.
2. Alarm-initiating connection to activate emergency lighting control.
3. Alarm-initiating connection to activate emergency shutoffs for gas and fuel supplies.
4. Supervisory connections at valve supervisory switches.
5. Supervisory connections at low-air-pressure switch of each dry-pipe sprinkler system.
6. Supervisory connections at fire-pump power failure including a dead-phase or phase-reversal condition.
7. Supervisory connections at fire-pump engine control panel.

### 3.3 IDENTIFICATION

A. Identify system components, wiring, cabling, and terminals. Comply with requirements for identification specified in Section 26 05 00 "Electrical Identification."

B. Install framed instructions in a location visible from fire-alarm control unit.

- C. All initiating devices shall have bar code label installed visibly on the device. This bar code shall be used for digital inspection of the fire alarm system using Building Reports.Com.

### 3.4 GROUNDING

- A. Ground fire-alarm control unit and associated circuits; comply with IEEE 1100. Install a ground wire from main service ground to fire-alarm control unit.

### 3.5 FIELD QUALITY CONTROL

- A. Field tests shall be witnessed by Architect, Engineer and authorities having jurisdiction.
- B. Manufacturer's Field Service: Engage a factory-authorized service representative to inspect, test, and adjust components, assemblies, and equipment installations, including connections.
- C. Perform tests and inspections.
  - 1. Manufacturer's Field Service: Engage a factory-authorized service representative to inspect components, assemblies, and equipment installations, including connections, and to assist in testing.
- D. Tests and Inspections:
  - 1. Visual Inspection: Conduct visual inspection prior to testing.
    - a. Inspection shall be based on completed Record Drawings and system documentation that is required by NFPA72 in its "Completion Documents, Preparation" Table in the "Documentation" Section of the "Fundamentals of Fire Alarm Systems" Chapter.
    - b. Comply with "Visual Inspection Frequencies" Table in the "Inspection" Section of the "Inspection, Testing and Maintenance" Chapter in NFPA72; retain the "Initial/Reacceptance" column and list only the installed components.
  - 2. System Testing: Comply with "Test Methods" Table in the "Testing" Section of the "Inspection, Testing and Maintenance" Chapter in NFPA72.
  - 3. Test audible appliances for the public operating mode according to manufacturer's written instructions. Perform the test using a portable sound-level meter complying with Type 2 requirements in ANSI S1.4.
  - 4. Test audible appliances for the private operating mode according to manufacturer's written instructions.
  - 5. Test visible appliances for the public operating mode according to manufacturer's written instructions.
  - 6. Factory-authorized service representative shall prepare the "Fire Alarm System Record of Completion" in the "Documentation" Section of the "Fundamentals of Fire Alarm Systems" Chapter in NFPA72 and the "Inspection and Testing Form" in the "Records" Section of the "Inspection, Testing and Maintenance" Chapter in NFPA72.
- E. Reacceptance Testing: Perform reacceptance testing to verify the proper operation of added or replaced devices and appliances.
- F. Fire-alarm system will be considered defective if it does not pass tests and inspections.
- G. Prepare test and inspection reports.

- H. Maintenance Test and Inspection: Perform tests and inspections listed for weekly, monthly, quarterly, and semiannual periods. Use forms developed for initial tests and inspections.
- I. Annual Test and Inspection: During the warranty period, each year test fire-alarm system complying with visual and testing inspection requirements in NFPA72. Use forms developed for initial tests and inspections.
- J. Detector Sensitivity Testing: During the warranty period, each year the contractor is to perform detector sensitivity testing and provide report to the Owner. Unless, the system is UL Listed to perform automatic sensitivity testing without any manual intervention and should detector fall outside of sensitivity window, the system will automatically indicated a devices trouble. A copy of UL letter is to be provided as proof of system operation

### 3.6 DEMONSTRATION

- A. Engage a factory-authorized service representative to train Owner's maintenance personnel to adjust, operate, and maintain fire-alarm system.

### 3.7 WIRING

#### A. Power Requirements:

- 1 The Fire Alarm Control Panel (FACP) and/or Notification Appliance Circuit (NAC) panels shall be connected to a separate 20 ampere, 120 volt dedicated branch circuit labeled as FIRE ALARM.
- 2 The Control Panel Cabinet shall be grounded securely using a copper grounding conductor.
- 3 Conduit shall enter into the Fire Alarm Control panel backbox only at those areas of the back box which have factory conduit knockouts.
- 4 All field wiring shall be completely supervised. In the event of a primary power failure, disconnected standby battery, removal of any internal modules, or any open circuits in the field wiring: an audible and visual trouble signal will be activated until system and its associated field wiring are restored to normal condition.

- B. Cables must be separated from any open conductors of Power, or Class 1 circuits, and shall not be placed in any conduit, junction box or raceway containing these conductors, as per NEC Article 760-29.

- C. SLC loops shall be loaded to no more than 75% of their capacity.

- D. Install wiring in accordance with Section 26 05 00 and shall be in accordance with the NEC, NFPA 72, local and state codes, as shown on the drawings, and as recommended by the major equipment manufacturer. See Article

- E. Provide all fire alarm system wiring drops to devices within raceways and junction boxes. Where existing conditions prohibit fishing existing walls, so as to avoid excessive cutting and restoration metallic wiremold finished to match existing wall surface shall be permitted where allowed by OWNER/ENGINEER, routing subject to OWNER/ENGINEER approval.

- F. All fire detection and alarm system devices, control panels and remote annunciators shall be flush mounted when located in finished areas and may be surface mounted when located in unfinished areas.

- G. Smoke detectors shall not be installed prior to the system programming and test period. If construction is ongoing during this period, measures shall be taken to protect smoke detectors from contamination and physical damage.

- H. All conduit, junction boxes, conduit supports and hangers shall be concealed in finished areas and may be exposed in unfinished areas if approved by Owner/Engineer before installation. All system junction

boxes shall be as manufactured by system supplier or painted red and stenciled with fire alarm system designation.

- I. All conductor identification shall be labeled in accordance with Section 26 05 00 at all accessible locations including at control panel, junction boxes and at devices for future tracing and maintenance.
- J. Coordinate connections with supplier of central station network system. SLC loop shall be 2 #16 shielded FPLR or FPLP cable as required.
- K. Signal circuit wiring shall be 2 conductor #14 or 2 conductor #12 FPLR or FPLP cable as required. 2#14 or 2#12 THHN is acceptable if signal circuits are enclosed in listed raceway. Synchronization modules shall be utilized to provide audio and visual synchronization over 2 conductors. Consult loading chart for proper wire gauge and wire length to insure against excessive DC voltage drop. A minimum of 20.5V DC must be available at the last signal of a NAC under full alarm condition.
- L. Provide 2 #14 from control panel or door holder power supply to door holders.

### 3.8 FREE AIR WIRING

- A. All wiring shall be run "free-air", in conduit or in surface raceway. "Free-air" wiring is allowed where it can be completely concealed. If wiring cannot be concealed, it shall be installed in wiremold in finished areas and in conduit in unfinished areas.
- B. Where installed "free-air", comply with the following:
  - 1. Cable shall run at right angles and be kept clear of other trades work.
  - 2. Cables shall be supported according to code utilizing bridle rings anchored to ceiling concrete, piping supports or structural steel beams. Rings shall be designed to maintain cables bend to larger than the minimum bend radius (typically 4 x cable diameter).
  - 3. Supports shall be spaced at a maximum 4-foot interval unless limited by building construction. If cable "sag" at mid-span exceeds 12-inches, another support shall be used.
  - 4. Cable shall never be laid directly on the ceiling grid.
  - 5. Cables shall not be attached to or supported by, existing cabling, plumbing or steam piping, ductwork, ceiling supports or electrical or communications conduit.
  - 6. A coil of 2 feet in each cable shall be placed in the ceiling at each "free-air" wired fire alarm device. These "service loops" shall be secured at the last cable support before the cable reaches the device and shall be coiled from 100% to 200% of the cable recommended minimum bend radius.
  - 7. Devices wired with conduit shall be provided with an 8-inch wire tail at each device box and 36-inch wire tails at the FACP and FAAP.
  - 8. To reduce or eliminate EMI, the following minimum separation distances from  $\leq 480V$  Power lines shall be adhered to:
    - a. Twelve (12) inches from power lines of  $<5\text{-kVa}$ .
    - b. Eighteen (18) inches from high voltage lighting (including fluorescent).
    - c. Thirty-nine (39) inches from power lines of 5-kVa or greater.
    - d. Thirty-nine (39) inches from transformers and motors.
  - 9. All cable shall be free of tension at both ends. In cases where the cable must bear some stress, Kellm grips shall be used to spread the strain over a longer length of cable.
  - 10. Manufacturers minimum bend radius specifications shall be observed in all instances. Care should be taken in the use of cable ties to secure and anchor the station cabling. Ties should not be over tightened as to compress the cable jacket. No sharp burrs should remain where excess length of the cable tie has been cut.
  - 11. All vertical cable extensions to fire alarm devices located below the finished ceiling shall be in



conduit.

- C. Contractor shall furnish all required installation tools to facilitate cable pulling without damage to the cable jacket. Such equipment is to include, but not limited to, sheaves, winches, cable reels, cable reel jacks, duct entrance tunnels, pulling tension gauge and similar devices. All equipment shall be of substantial construction to allow steady progress once pulling has begun. Makeshift devices, which may move or wear in a manner to pose a hazard to the cable, shall not be used.
- D. All cable shall be pulled by hand unless installation conditions require mechanical assistance. Where mechanical assistance is used, care shall be taken to insure that the maximum tensile load for the cable as defined by the manufacturer is not exceeded. This may be in the form of continuous monitoring of pulling tension, use of a “break-away” or other approved method.

### 3.9 DEPARTMENT OF SAFETY AND PROFESSIONAL SERVICES SUBMITTAL

- A. This Contractor is responsible for making required submittals.
- B. Pay fees for reviewing submittal.
- C. Make submittal after engineering review has been obtained for shop drawings.
- D. Incorporate any REVIEW comments into shop drawings and as-builts.
- E. This Contractor is responsible to pay all local fire department fees.

END OF SECTION 28 31 00

Page Intentionally Left Blank

# DANE COUNTY JOB CENTER RESTROOM EXPANSION 1819 ABERG AVENUE MADISON, WISCONSIN

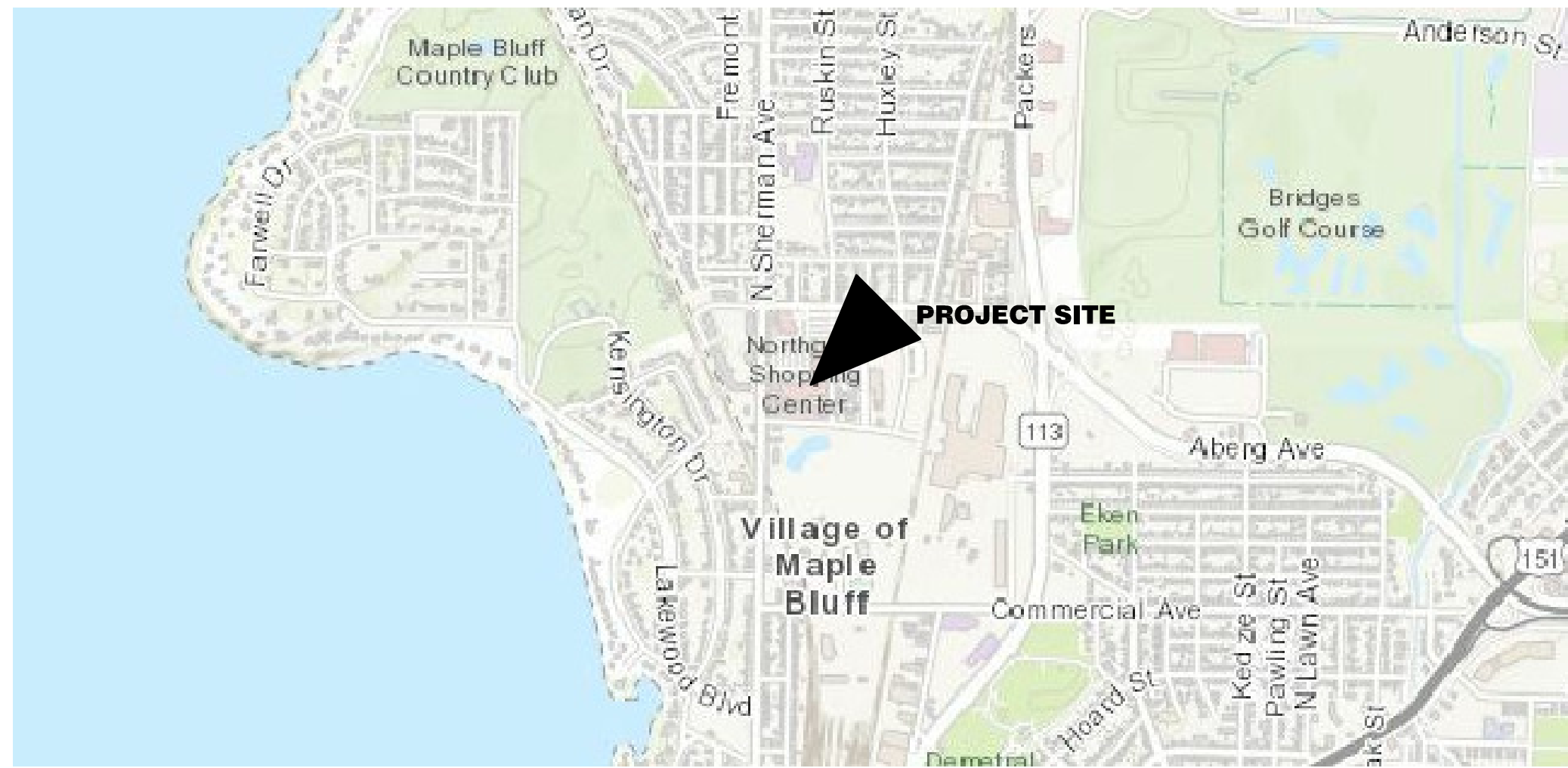

MADISON, WISCONSIN



KEY PLAN AND ADA ACCESSIBLE ROUTE

## INDEX OF DRAWINGS

**GENERAL**  
G1.0 COVER SHEET AND INDEX OF DRAWINGS

**ARCHITECTURAL**  
A2.1 PARTIAL FIRST FLOOR PLANS, REFLECTED CEILING PLANS AND FINISH PLANS  
A7.0 DOOR SCHEDULE, INTERIOR ELEVATIONS AND DETAILS  
A7.1 INTERIOR ELEVATIONS

**STRUCTURAL**  
S0.0 STRUCTURAL GENERAL NOTES  
S5.1 STEEL FRAME DETAILS

**FIRE PROTECTION**  
FP1.0 PARTIAL FIRST FLOOR FIRE PROTECTION PLANS

**PLUMBING**  
P1.0 PARTIAL FIRST FLOOR PLANS, DEMOLITION/ GENERAL PLUMBING NOTES, PLUMBING ABBREVIATIONS AND PLUMBING SYMBOLS  
P2.0 PLUMBING WASTE VENT AND WATER PIPING DIAGRAM

**HVAC**  
M1.0 PARTIAL FIRST FLOOR HVAC DEMOLITION & NEW WORK PLANS  
M2.0 HVAC SCHEDULES AND DETAILS

**ELECTRICAL**  
E1.1 PARTIAL FIRST FLOOR ELECTRICAL DEMOLITION AND NEW PLANS  
E2.1 ELECTRICAL SCHEDULES AND DETAILS

## ARCHITECTURAL SYMBOLS AND LEGEND

	DETAIL REFERENCE
	SHEET REFERENCE
	DETAIL NUMBER
	WALL SECTION REFERENCE
	SHEET REFERENCE
	DETAIL NUMBER
	ELEVATION REFERENCE
	PARTITION TYPE. REF. SEE SHEET A7.0
	NEW WALLS
	WINDOW TYPES SEE A7.0
	1 HOUR FIRE RATED WALL
	2 HOUR FIRE RATED WALL
	DOOR SWING w/NUMBER. SEE A7.0
	EXISTING DOOR SWING w/NUMBER. SEE A7.0
	REVISIONS
	RECESSED FIRE EXTINGUISHER
	SURFACE MOUNT FIRE EXTINGUISHER
	SPOT ELEVATION (FEET-INCHES)
	SPOT ELEVATION (FEET.DECIMAL)
	ROOM NAME & NUMBER SEE FINISH PLAN SHEET A900s

## ABBREVIATIONS

ADA	AMERICANS WITH DISABILITIES ACT
A.F.F.	ABOVE FINISHED FLOOR
AL	ALUMINUM
AP	ACCESS PANEL
CG	CORNER GUARD
CHW	CLOTHES HOOK MOUNTED ON WALL
CJ	CONTROL JOINT
CMU	CONCRETE MASONRY UNIT
CONC	CONCRETE
CPT	CARPET
CT	CERAMIC TILE
CUH	CABINET UNIT HEATER
EJ	EXPANSION JOINT
EWC	ELECTRIC WATER COOLER
EHD	ELECTRIC HAND DRYER
FD	FLOOR DRAIN
FD	FOUNDATION DRAIN SYSTEM FLUSHOUT
FRT	FIRE TREATED
FX-#	FIRE EXTINGUISHER AND TYPE
GWB	GYPSUM WALL BOARD
HM	HOLLOW METAL
MB	MARKER BOARD
TB	TACK BOARD
M	MIRROR
BB	BULLETIN BOARD
M.O.	MASONRY OPENING
N.I.C.	NOT IN CONTRACT
O.F.C.I.	OWNER FURNISHED CONTRACTOR INSTALLED
O.F.O.I.	OWNER FURNISHED OWNER INSTALLED
OPP	OPPOSITE
P.LAM.	PLASTIC LAMINATE
REV	REVERSE
R.O.	ROUGH OPENING
S.S.	STAINLESS STEEL
SLS	SOLID SURFACE
TD	TOWEL DISPENSER
TZO	TERRAZZO
U.N.O.	UNLESS NOTED OTHERWISE
VCT	VINYL COMPOSITION TILE
WD	WOOD
WP	WATER PROOFING
WPT	WORK POINT
WR	WASTE RECEPTACLE

MAJOR USE & OCCUPANCY CLASSIFICATION: B  
CONSTRUCTION CLASSIFICATION: IB  
GROSS FLOOR AREA OF RENOVATION:  
SPRINKLERED  
MAXIMUM EXIT ACCESS TRAVEL DISTANCE: 300'

## TOILET ACCESSORY SCHEDULE:

ABBREVIATION	STD. MOUNTING HEIGHT
AP	SEE PLAN AND ELEVATION
CHW	(1) 5'-4" A.F.F., (1) 4'-0" A.F.F. SEE ELEVATIONS FOR OTHER LOCATIONS
EWC	(1) 2'-11" A.F.F. TO SPOUT OUTLET, (1) 3'-5" A.F.F. TO SPOUT OUTLET
ED	TOP @ 41.25" MALE, 38.25" FEMALE
FD	SEE PLUMBING SPECIFICATION
FS	TOP @ 17'-10" A.F.F.
GB8	CENTER @ 2'-10" A.F.F., 3'-2" A.F.F. IN SHOWER
GB18	HORIZ: CENTER @ 2'-10" A.F.F.; VERT: 3'-4" @ B.O. BAR HORIZ: CENTER @ 3'-2" A.F.F.; VERT: 3'-7" @ B.O. BAR IN SHOWER
GB36	CENTER @ 2'-10" A.F.F., 3'-2" A.F.F. IN SHOWER
GB48	CENTER @ 2'-10" A.F.F., 3'-2" A.F.F. IN SHOWER
GB80	CENTER @ 2'-10" A.F.F., 3'-2" A.F.F. IN SHOWER
LAV	TYPICAL: TOP @ 2'-10" A.F.F. PRESCHOOL: TOP @ 1'-8" A.F.F.
M	BOTTOM @ 3'-4" MAX A.F.F.
SD	TOP @ 45" A.F.F.
SDL	LAVATORY MOUNTED
SHD	48" A.F.F. MAX TO OPERATING COMPONENTS (SEE PLAN)
SNL	TOP @ 15" MIN, 48" MAX A.F.F.
TDWR	48" A.F.F. MAX TO OPERATING COMPONENTS (SEE PLAN)
TPH	OUTLET 15" MIN, 48" MAX A.F.F., 7'-0" IN FRONT OF WC TO CL (SEE PLAN)
WC	SEE PLUMBING
WR	TOP @ 41-45" A.F.F. MAX., BASED ON SPECIFIED PRODUCT (SEE PLAN)

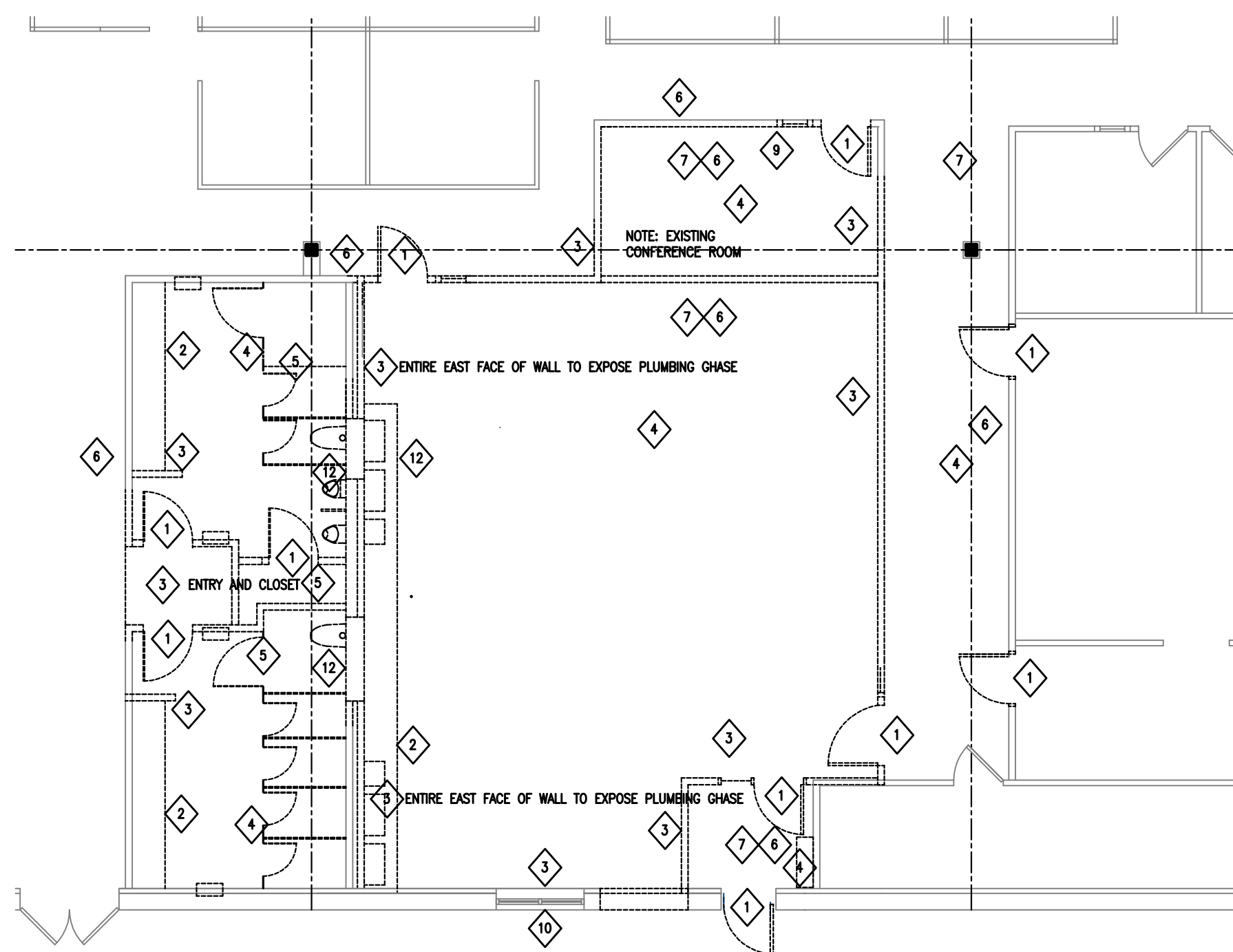

1 PARTIAL FIRST FLOOR PLAN - DEMOLITION  
1/8"=1'-0"

DEMOLITION NOTES	
1	DEMO DOOR AND HM FRAME. SALVAGE HARDWARE AND TURN OVER TO OWNER.
2	DEMO CASEWORK IN ITS ENTIRETY.
3	DEMO PORTION OF EXISTING WALL.
4	DEMO ALL TOILET PARTITIONS AND ACCESSORIES. TURN OVER ANY REQUESTED ACCESSORIES TO OWNER.
5	DEMO CERAMIC FLOOR AND WALL TILE.
6	REMOVE EXISTING RESILIENT BASE, WOOD CHAIR RAIL.
7	DEMO RESILIENT FLOOR OR CARPET. SALVAGE CARPET FOR REPAIR OF EXISTING CARPET ADJACENT TO WORK.
8	DEMO ACT AND GRID (INCLUDING SUSPENSION CLIPS) SALVAGE TILE FOR REINSTALLATION IN OPEN OFFICE 059 AND JAN 081
9	DEMO GYP. FOR INSTALLATION OF WALL TO STRUCTURE. REFER TO PARTITION TYPE.
10	REMOVE AND SALVAGE MASONRY FOR REINSTALLATION
11	DEMO GWB CEILING IN ITS ENTIRETY.
12	DEMOLISH EXISTING SLAB FOR MECHANICAL, ELECTRICAL AND PLUMBING WORK. SEE MEP FOR INFORMATION. APPROXIMATE LOCATION FOR SAWCUTTING FLOOR FOR PLUMBING INSTALLATION IS SHOWN ON PLUMBING DRAWINGS.
CUT AND PATCH EXISTING WALLS FOR INSTALLATION OF FIXTURES INCLUDING ROUGH IN, BLOCKING AND BRACING	

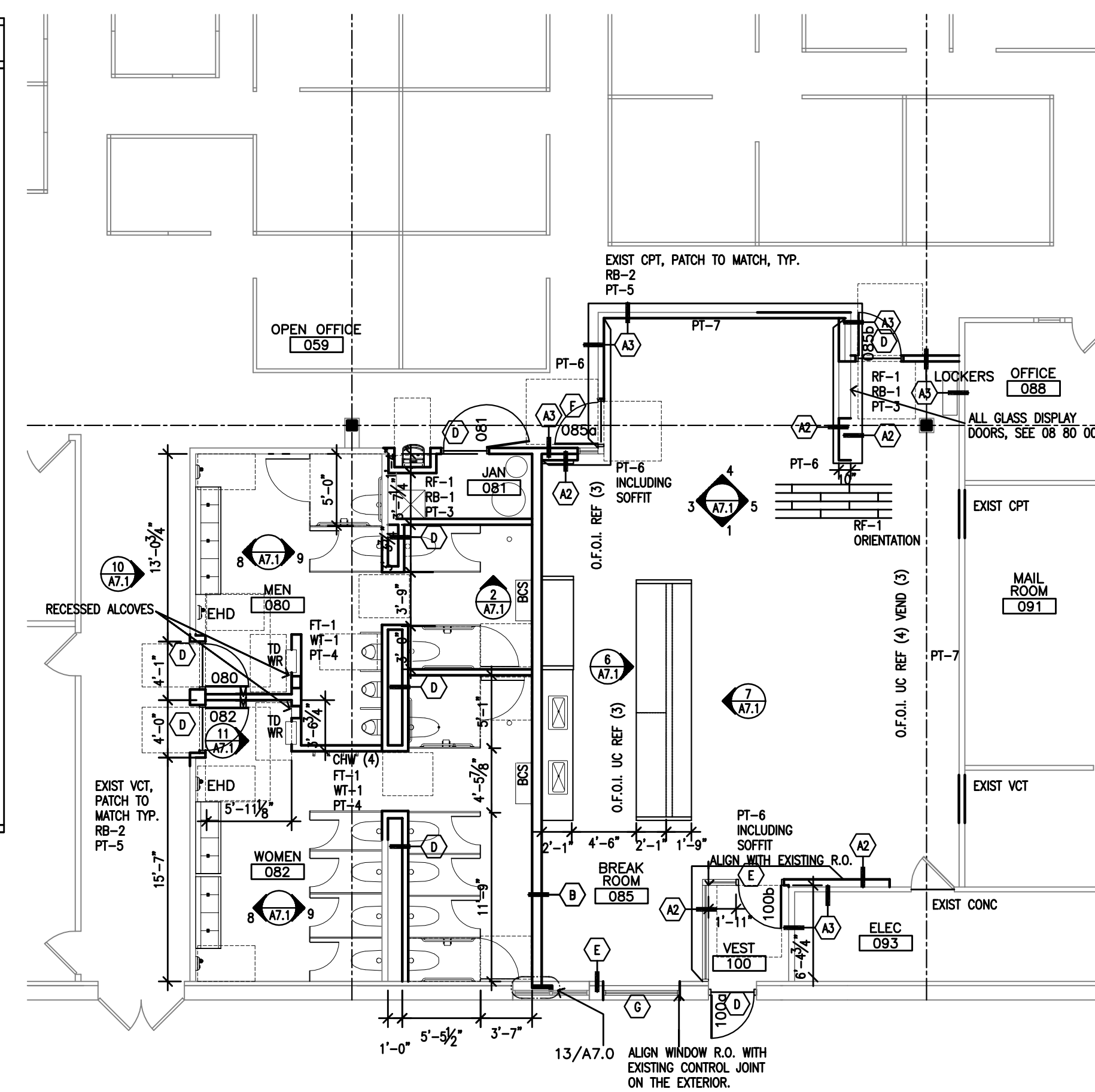

2 PARTIAL FIRST FLOOR PLAN  
1/8"=1'-0"

GENERAL NOTES:	
1.	FIELD VERIFY ALL EXISTING CONDITIONS, NOTIFY ARCHITECT OF ANY DISCREPANCIES.
2.	SEE MECHANICAL FOR COORDINATION OF EQUIPMENT LOCATIONS.
3.	SEE ELECTRICAL FOR FIXTURE TYPES.
4.	CENTER ALL FIXTURES IN ACT.
5.	SEE ROOM FINISH SCHEDULE FOR MORE INFORMATION.
6.	PREFERRED SPRINKLER HEAD LOCATIONS INDICATED. INSTALL PER NFPA 13, SEE SPECIFICATION SECTION C15010.
7.	SEE HVAC DRAWINGS FOR SCOPE OF WORK ON THE ROOF.

PHASING NOTES:	
1.	THE BUILDING WILL REMAIN OCCUPIED DURING CONSTRUCTION. MINIMIZE THE DURATION OF TIME THAT RESTROOMS (MEN 080 AND WOMEN 082) ARE NOT OCCUPIED. MAINTAIN USE OF THE EXISTING RESTROOMS (MEN 080 AND WOMEN 082) UNTIL THE EXPANSION WORK IS SUBSTANTIALLY COMPLETE AND READY FOR CONNECTIONS. ALL RESTROOM FINISHES MAY BE COMPLETED WHEN THE FULL SCOPE OF WORK IS COMPLETE AND READY FOR FINISHES.
2.	MAINTAIN USE OF CONFERENCE ROOM UNTIL BREAKROOM IS SUBSTANTIALLY COMPLETE. ALL BREAKROOM FINISHES MAY BE COMPLETED AFTER THE ROOMS ARE CONNECTED.
3.	COMPLETE ALL BREAKROOM SCOPE BEFORE WORK BEGINS IN THE EXISTING RESTROOMS.

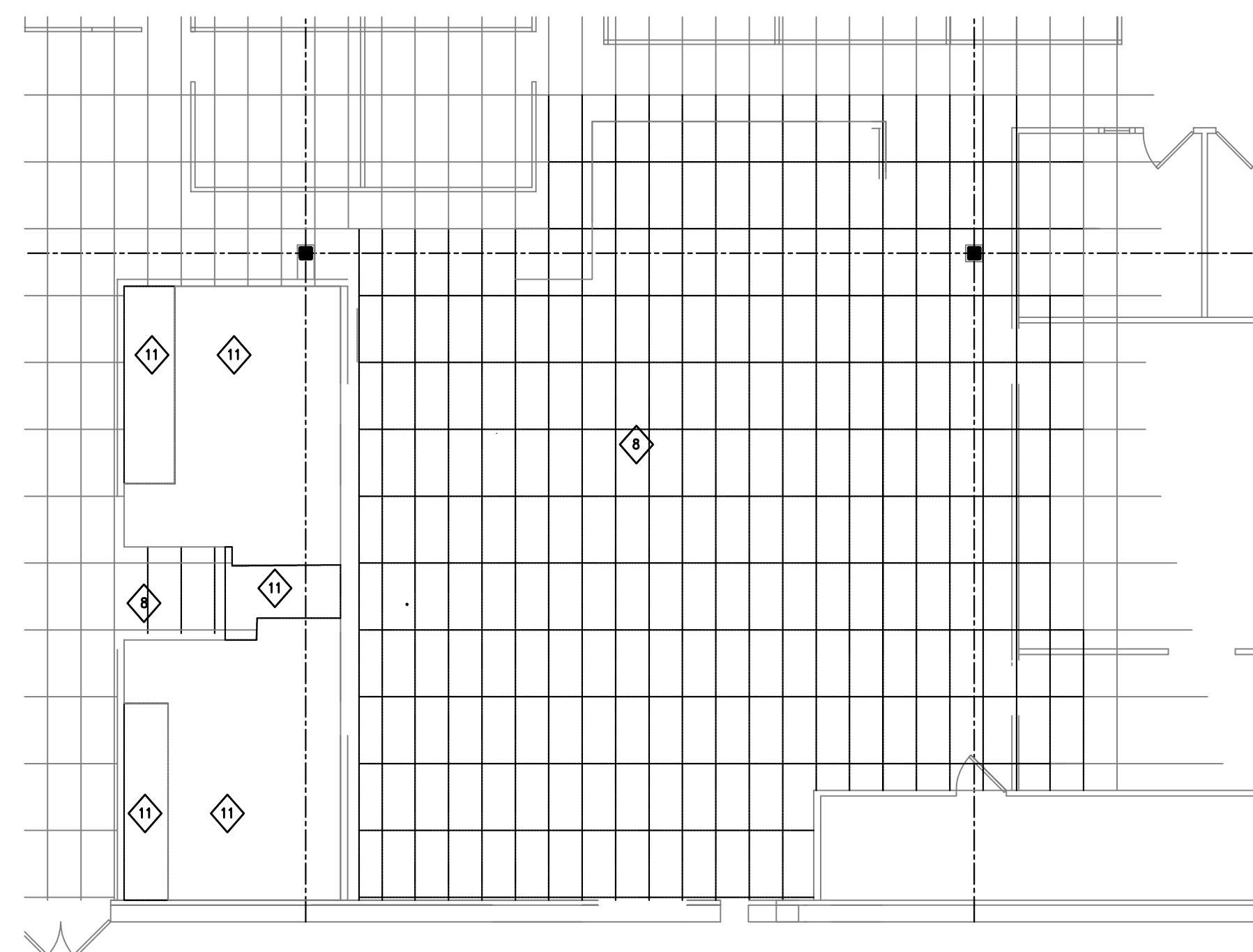

3 PARTIAL FIRST FLOOR REFLECTED CEILING PLAN DEMO  
1/8"=1'-0"

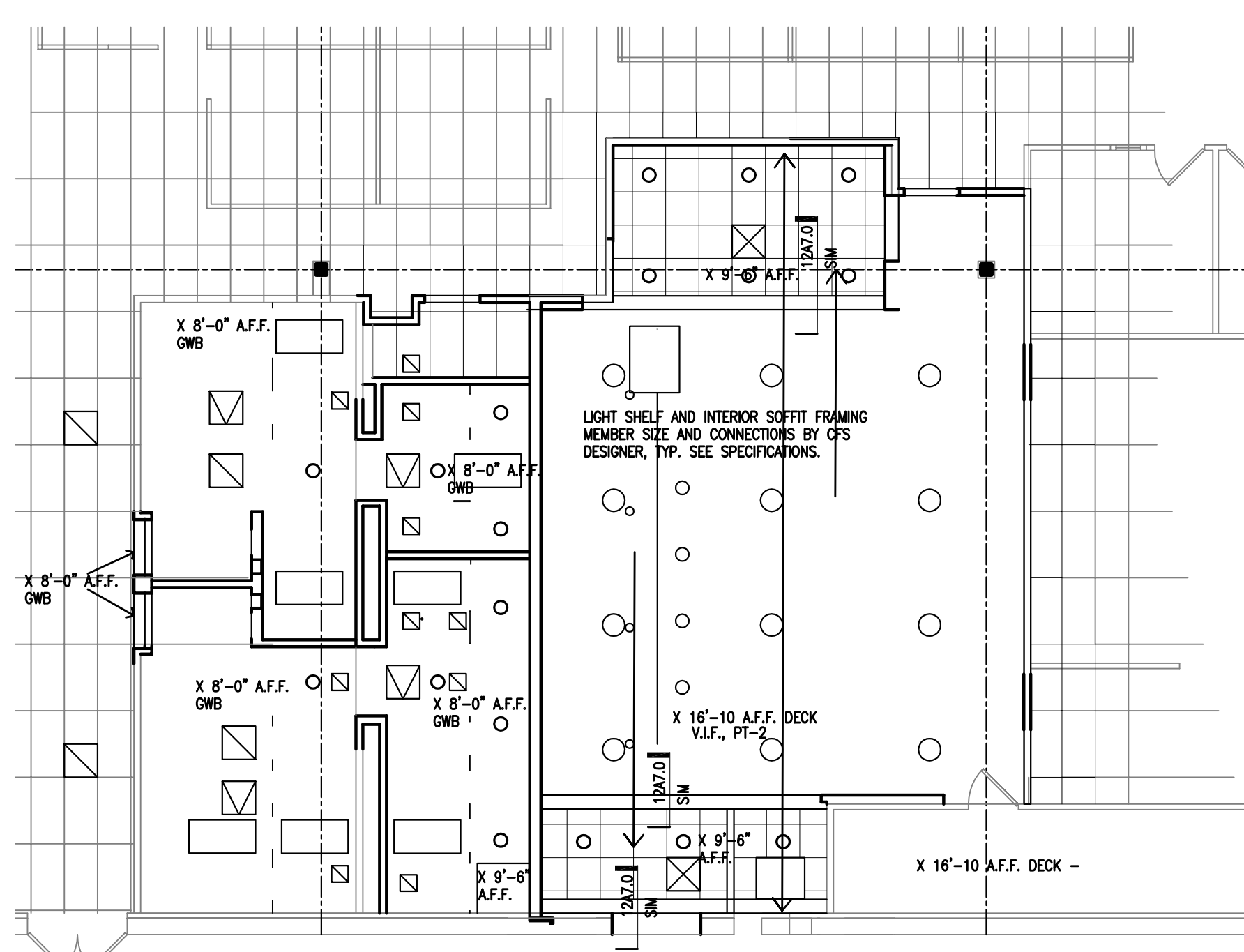

4 PARTIAL FIRST FLOOR REFLECTED CEILING PLAN  
1/8"=1'-0"

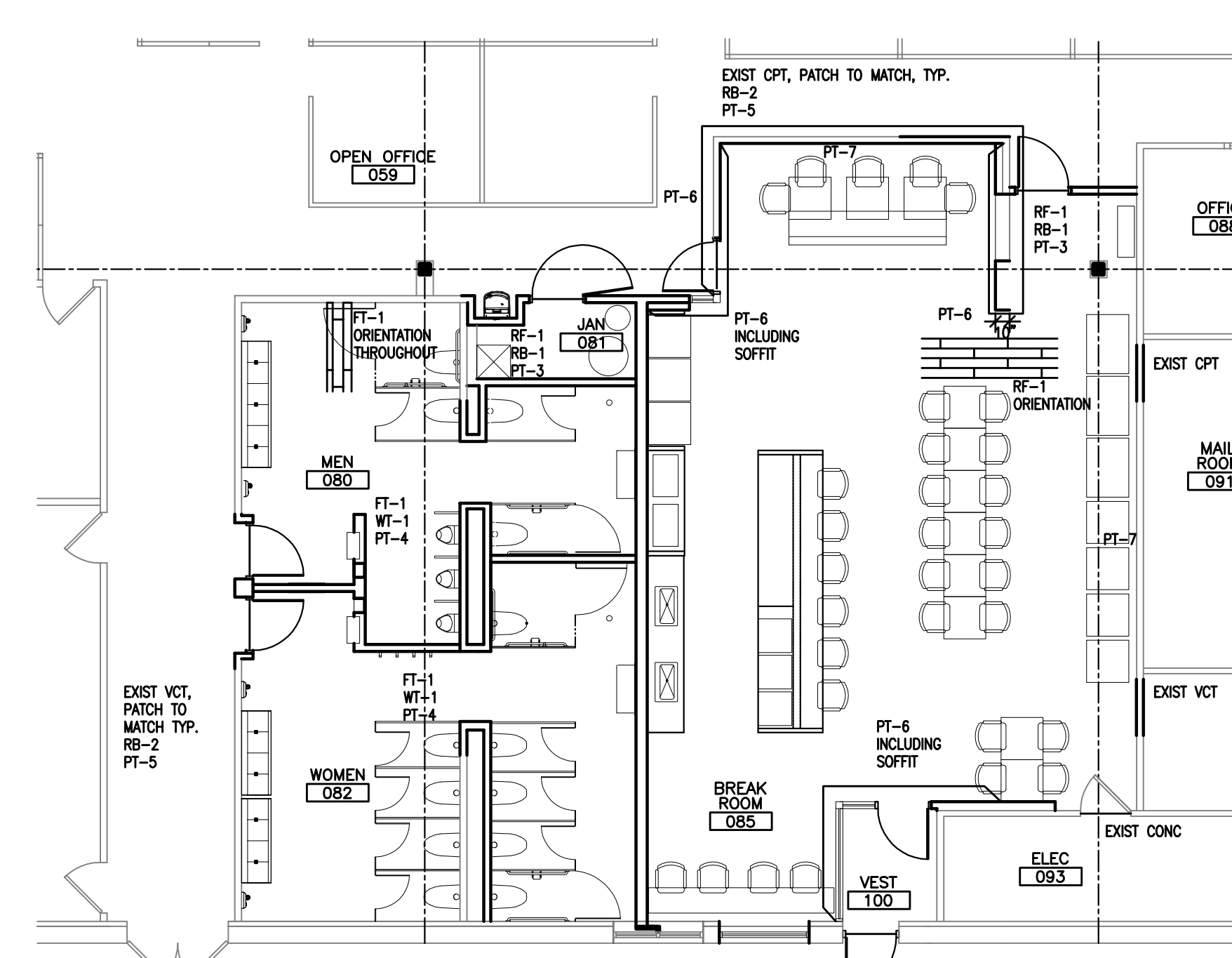

5 PARTIAL FIRST FLOOR FINISH PLAN AND ILLUSTRATIVE FURNITURE  
1/8"=1'-0"

PROVIDE STRUCTURE AND BRACING FOR CEILING HUNG TOILET PARTITIONS. SEE SPEC.  
CFS HEADER BY COLD FORMED DESIGNER AT OPENINGS IN PLUMBING CHASE WALL.  
CFS JOISTS SPANNING NORTH/SOUTH SPACING TO ACCOMMODATE HVAC RECESSED UNITS, SEE HVAC.  
OTHERWISE CFS JOISTS AT 16" O.C. PROVIDE ADDITIONAL INFILL BETWEEN JOISTS TO SUPPORT SUSPENDED PARTITIONS AS REQUIRED BY PARTITION MANUFACTURER. JOIST SIZE AND CONNECTIONS BY COLD FORM DESIGNER.

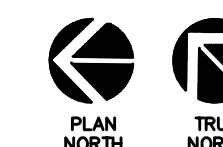

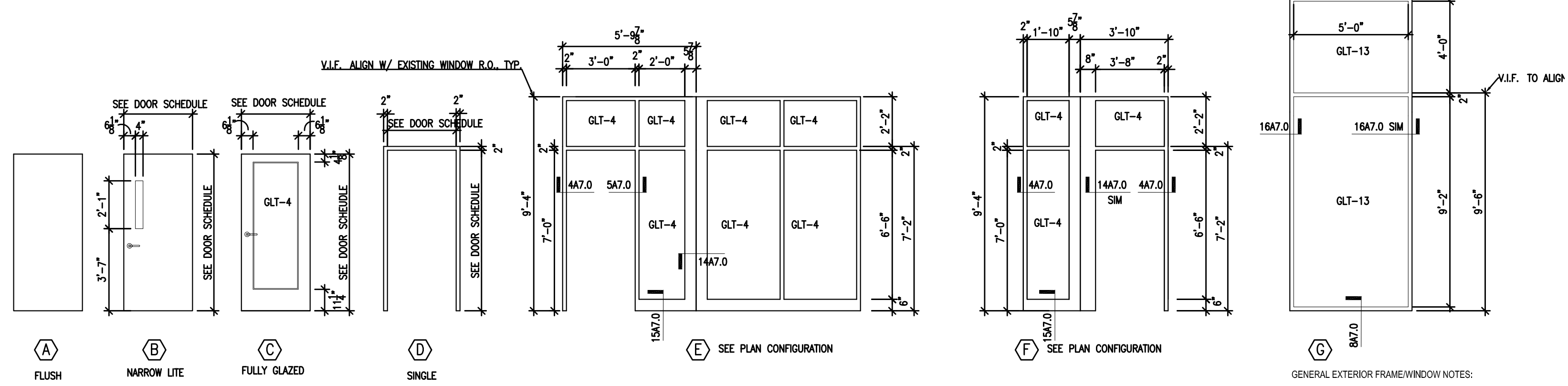

1 DOOR, FRAME AND WINDOW ELEVATIONS  
1/4"=1'-0"

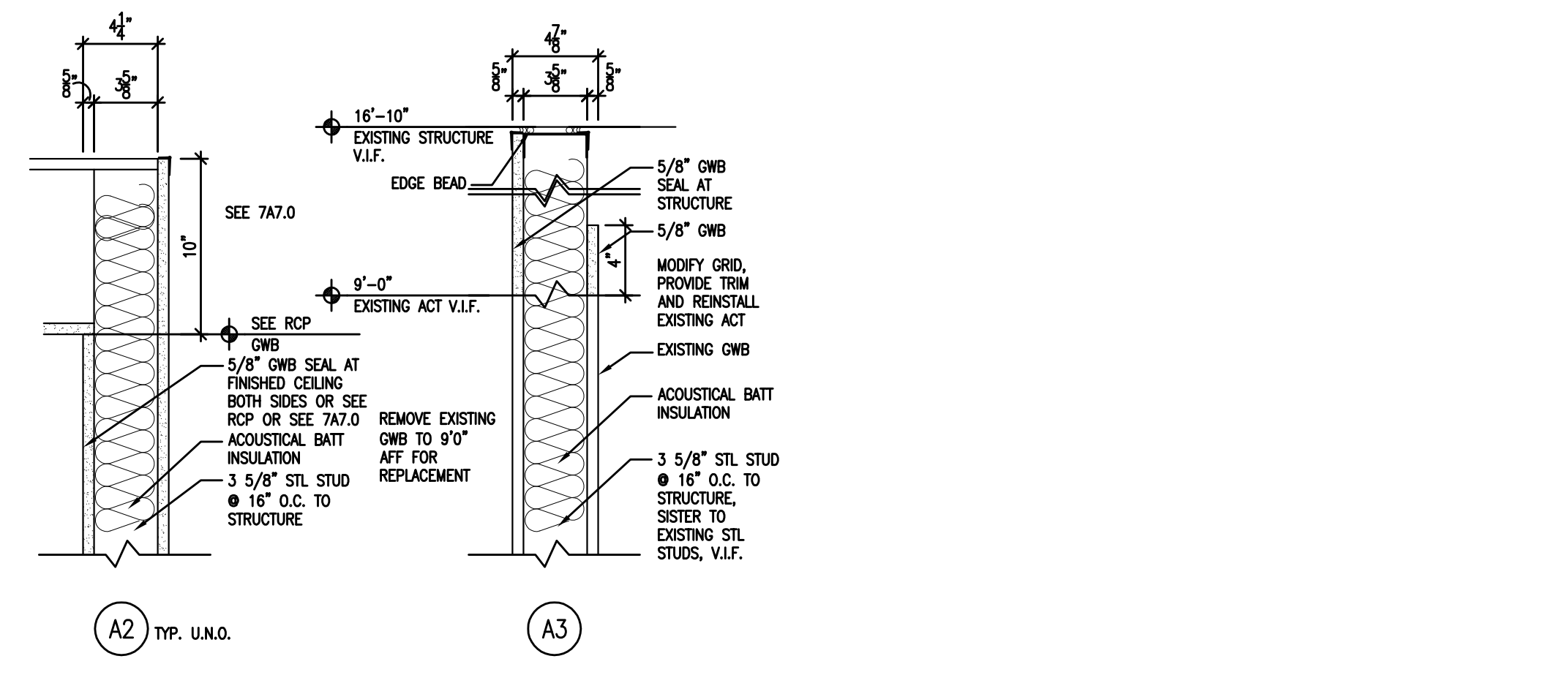

2 PARTITION TYPES  
1/2"=1'-0"

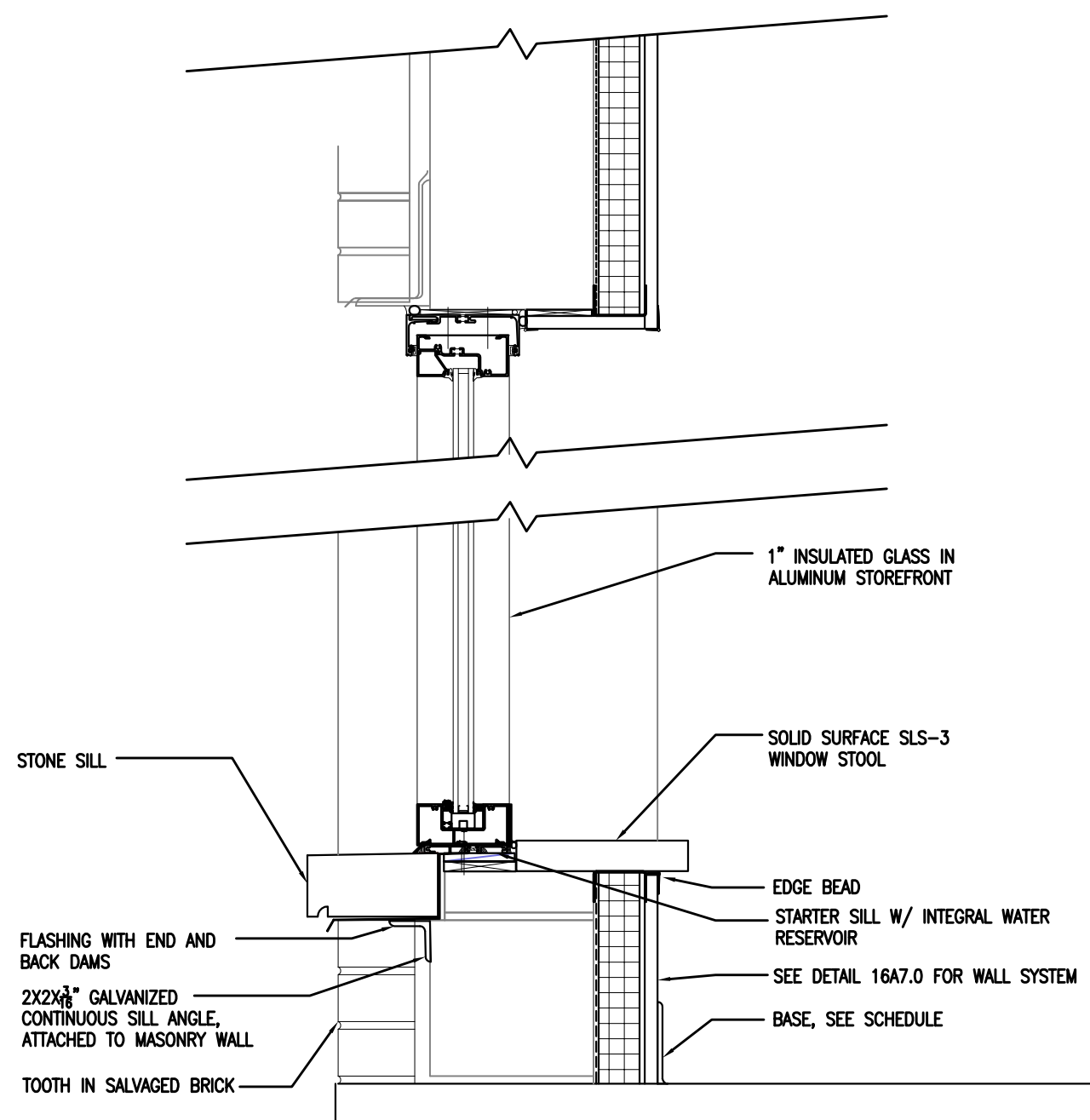

8 ALUMINUM STOREFRONT SILL  
1/2"=1'-0"

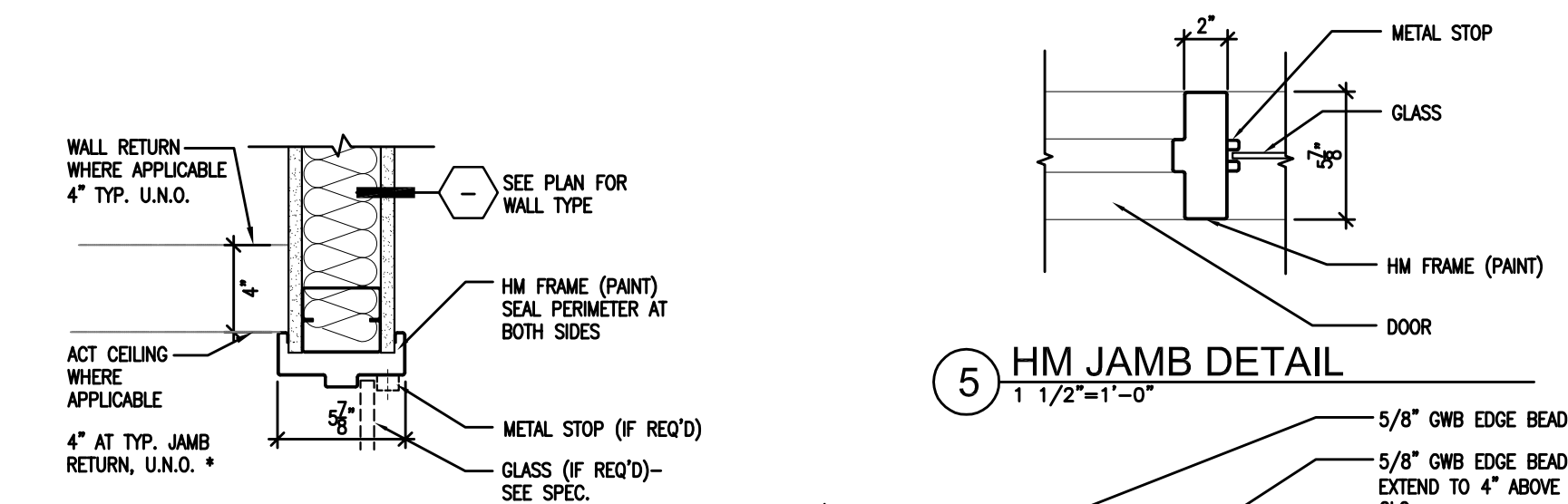

5 HM JAMB DETAIL  
1/2"=1'-0"

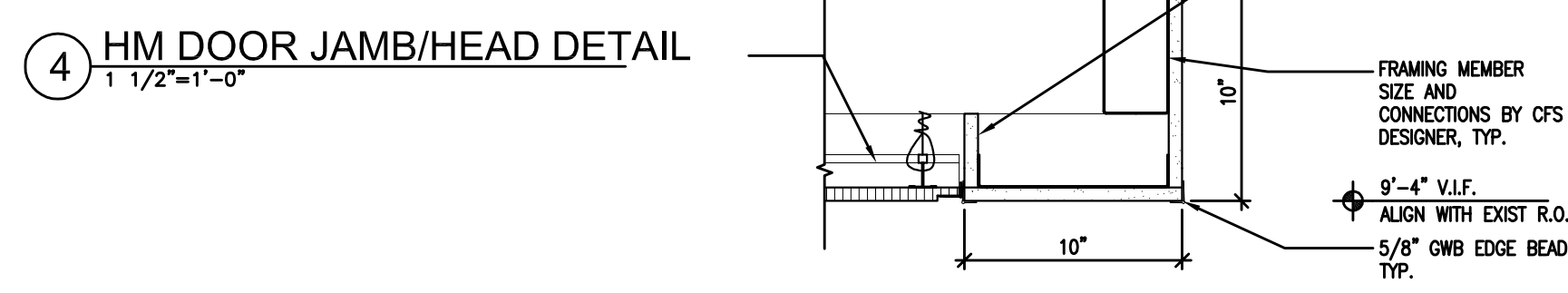

4 HM DOOR JAMB/HEAD DETAIL  
1/2"=1'-0"

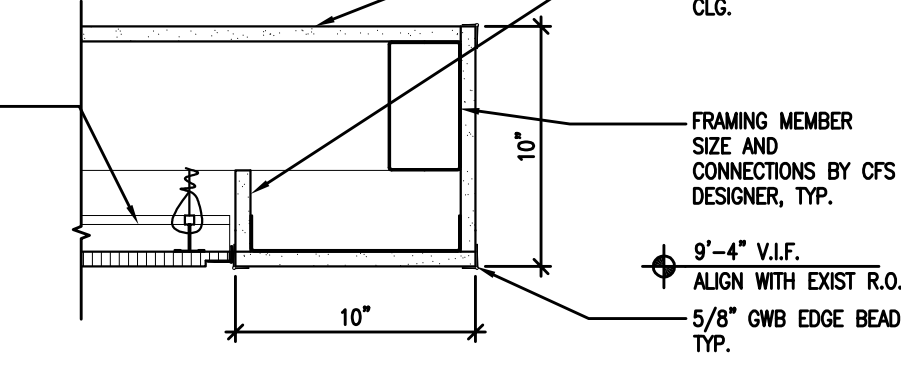

7 BULKHEAD DETAIL  
1/2"=1'-0"

DOOR NO.	QNTY	DOOR				FRAME			FIRE LABEL	HWDR GROUP	REMARKS					
		W	H	T	MATERIAL	ELEV	GLASS	LOUVER OR UNDERCUT								
080	1	3'-0"	7'-0"	-	WD	A	4	-	HM	D	4/A7.0	5/A7.0	6/A7.0	-	1A	
081	1	3'-0"	7'-0"	-	WD	A	4	-	HM	D	4/A7.0	5/A7.0	6/A7.0	-	2A	
082	1	3'-0"	7'-0"	-	WD	A	4	-	HM	D	4/A7.0	5/A7.0	6/A7.0	-	1A	
085A	1	3'-0"	7'-0"	-	WD	C	4	-	HM	F	4/A7.0	14/A7.0	15/A7.0	-	1A	
085B	1	3'-0"	7'-0"	-	WD	C	4	-	HM	D	4/A7.0	5/A7.0	6/A7.0	-	1A	
100a	1	3'-0"	7'-0"	-	WD	C	4	-	HM	D	16/A7.0	16/A7.0	6/A7.0	-	3A	REINSTALL CARD READER
100b	1	3'-0"	7'-0"	-	HM	C	4	-	HM	E	4/A7.0	14/A7.0	15A/7.0	-	1A	

GENERAL NOTES:  
 1. PAINT HM FRAMES, EXISTING HM DOORS AND FRAMES SCHEDULED AND EXISTING NOTED ON PLAN TO MATCH OWNER'S SAMPLE.  
 2. STAIN WOOD DOORS TO MATCH OWNER'S SAMPLE.  
 3. FIELD VERIFY ALL DIMENSIONS.  
 4. REFER TO SHEET A7.0 FOR HOLLOW METAL FRAME ELEVATIONS.

LEGEND	
AL	ALUMINUM
HM	HOLLOW METAL
WD	WOOD
UC	UNDERCUT

REMARKS:  
 2. FIELD VERIFY DOOR DIMENSIONS TO FIX EXISTING ROUGH OPENING.

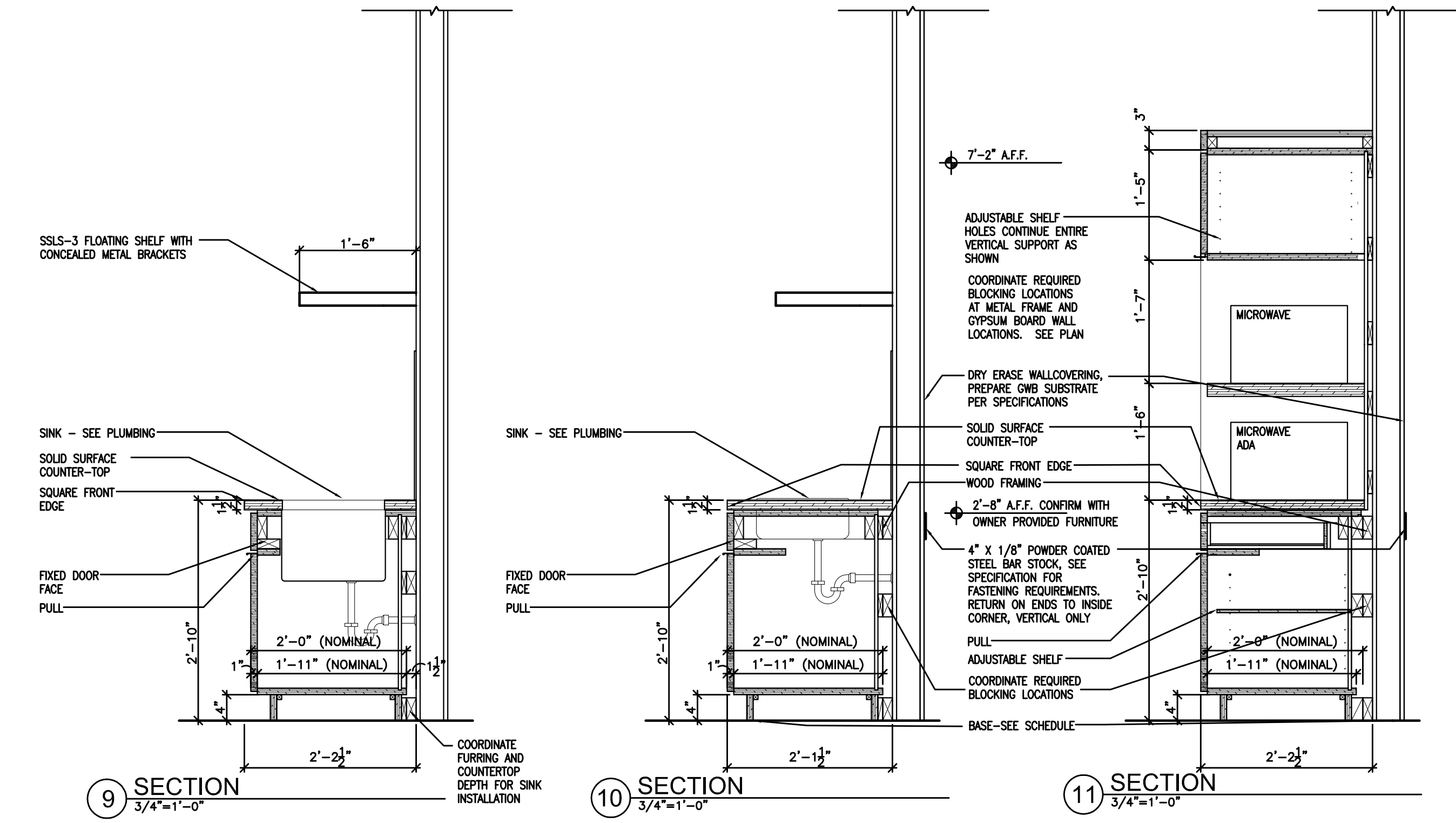

9 SECTION  
3/4"=1'-0"

10 SECTION  
3/4"=1'-0"

11 SECTION  
3/4"=1'-0"

12 SECTION  
3/4"=1'-0"

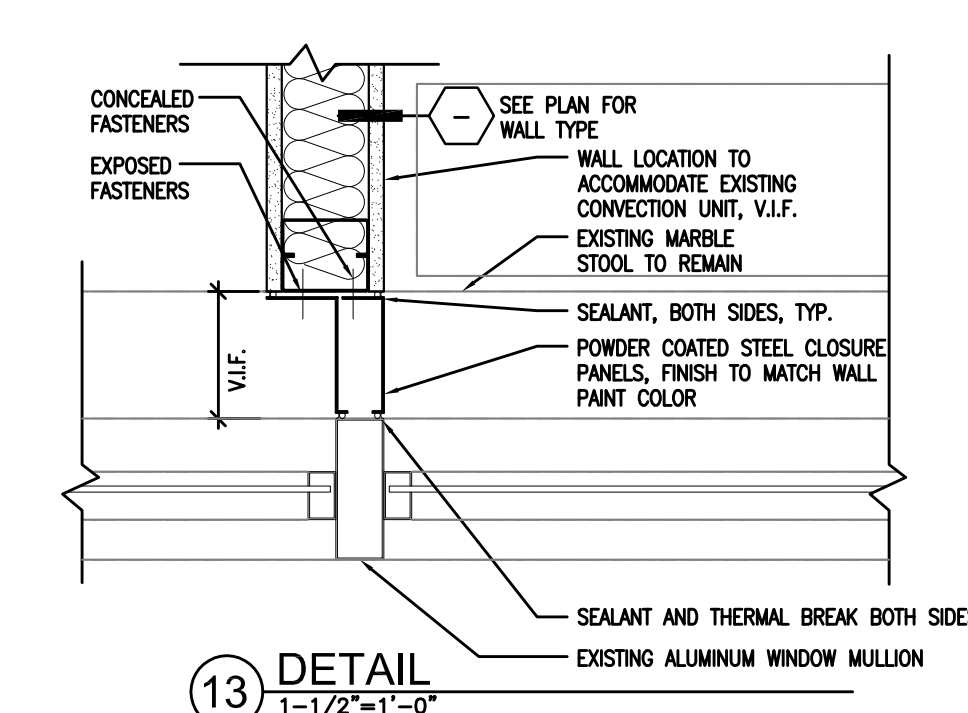

13 DETAIL  
1-1/2"=1'-0"

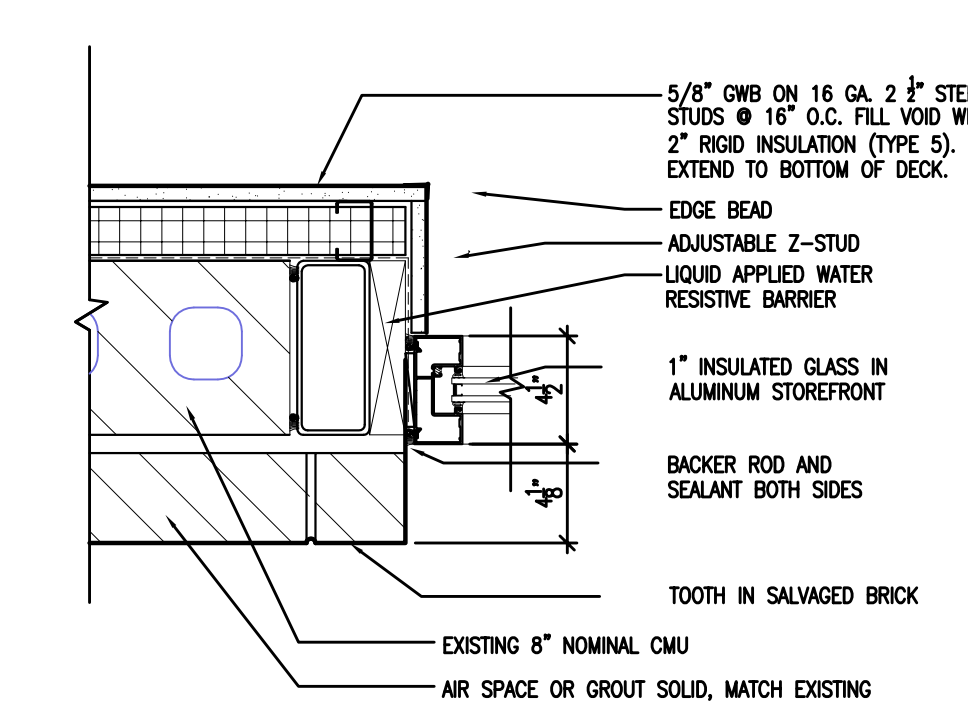

16 ALUMINUM STOREFRONT JAMB, HEAD SILL  
1-1/2"=1'-0"

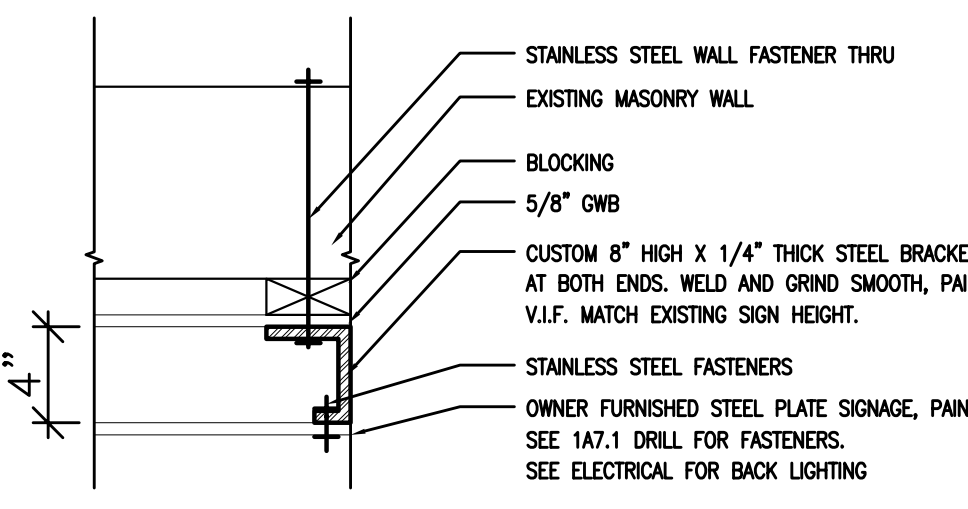

17 DETAIL  
1-1/2"=1'-0"

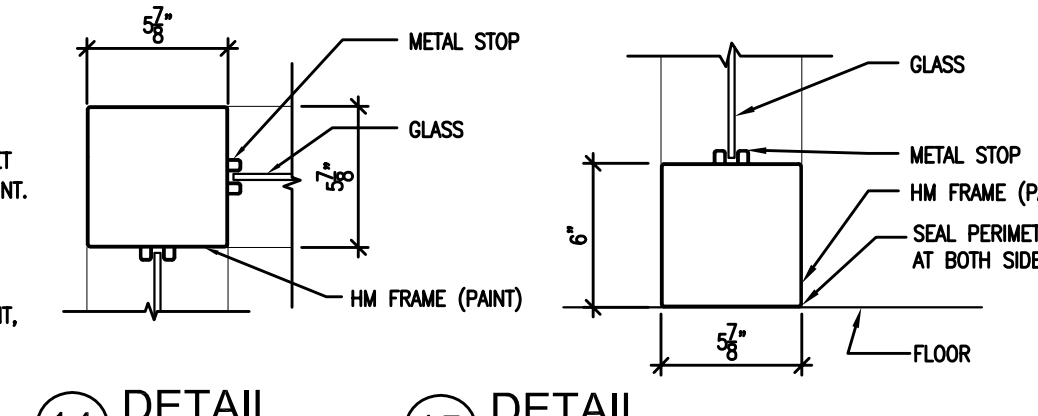

14 DETAIL  
1-1/2"=1'-0"

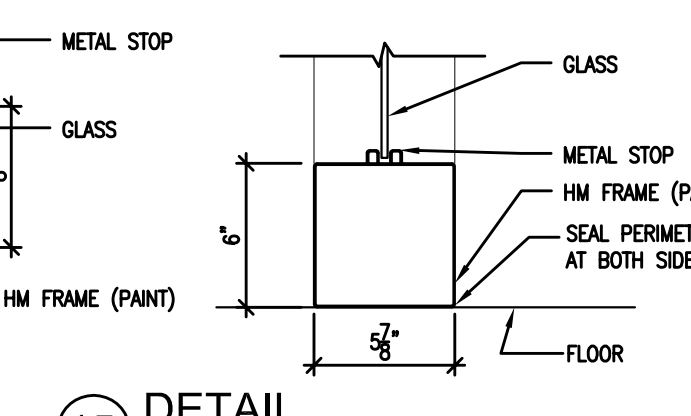

15 DETAIL  
1-1/2"=1'-0"

Architecture  
Planning

DorschnerAssociates, Inc.  
849 E. Washington Ave., Ste 112  
Madison, Wisconsin 53703

ISSUED

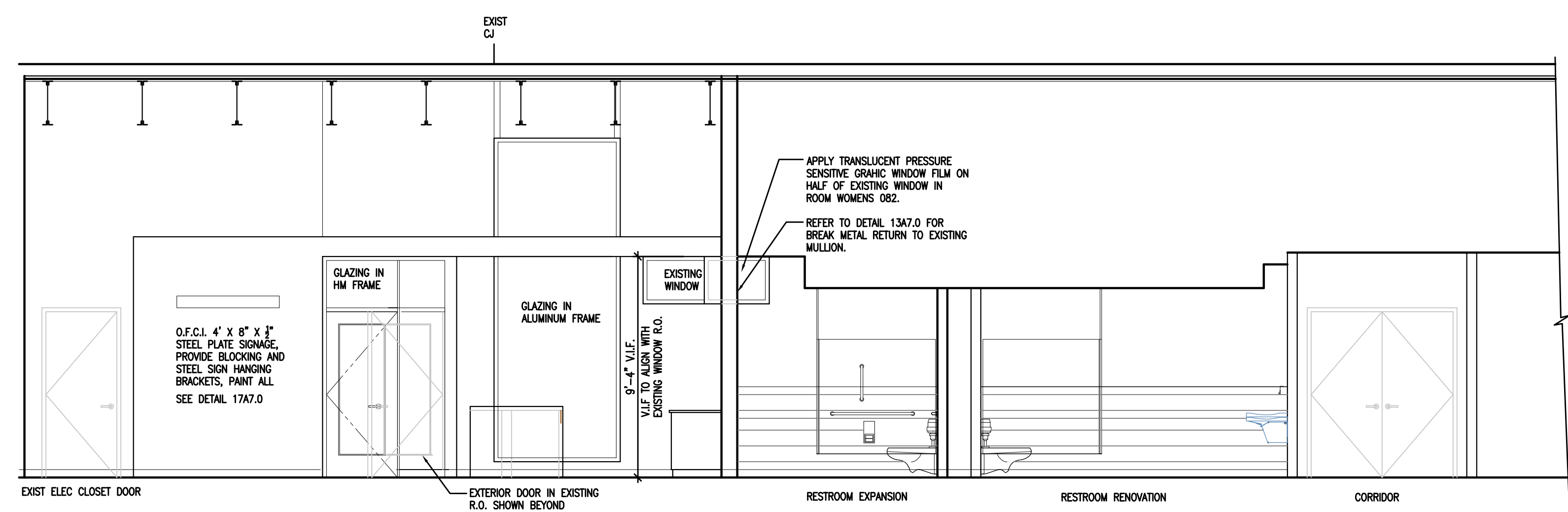

1 SOUTH INTERIOR ELEVATION  
1/8"=1'-0"

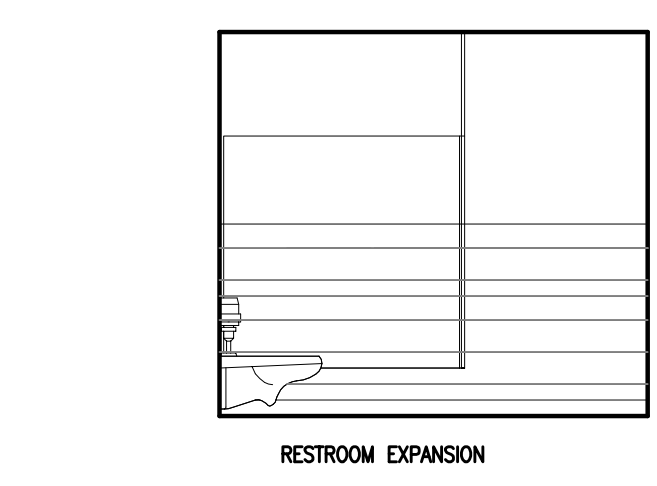

2 NORTH INTERIOR ELEVATION  
1/8"=1'-0"

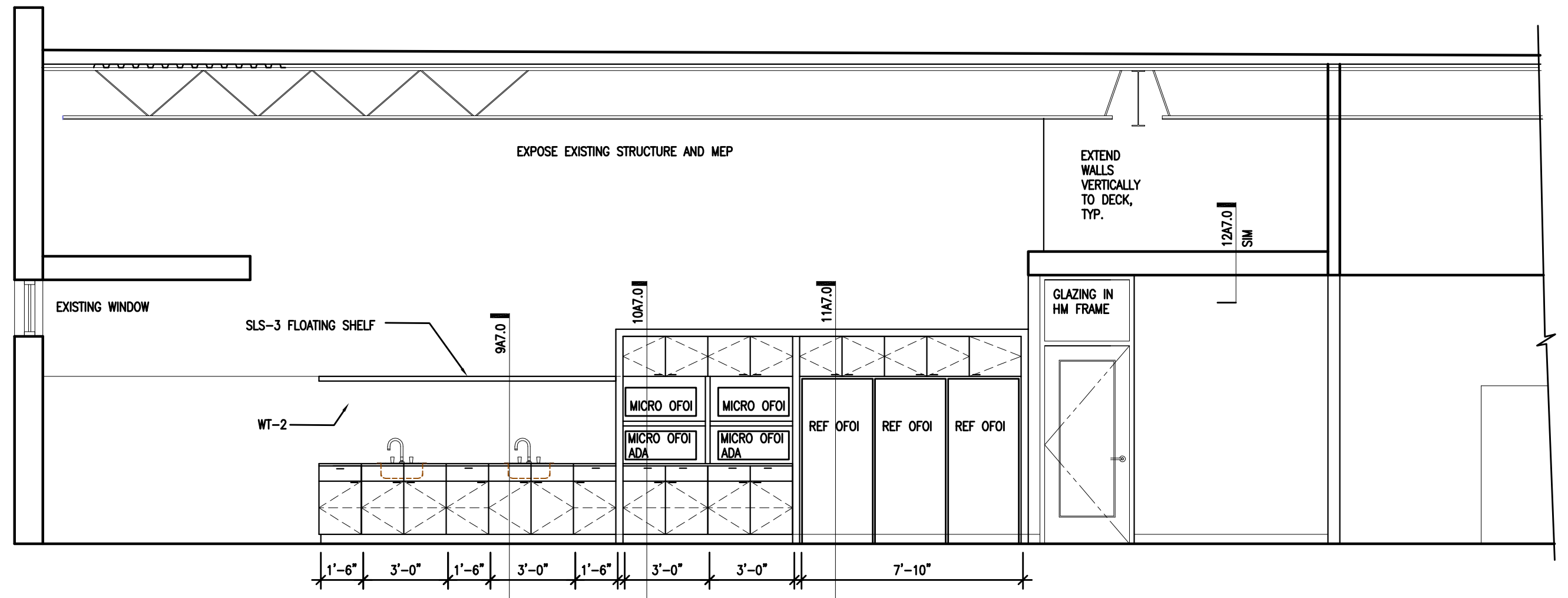

3 WEST INTERIOR ELEVATION  
1/8"=1'-0"

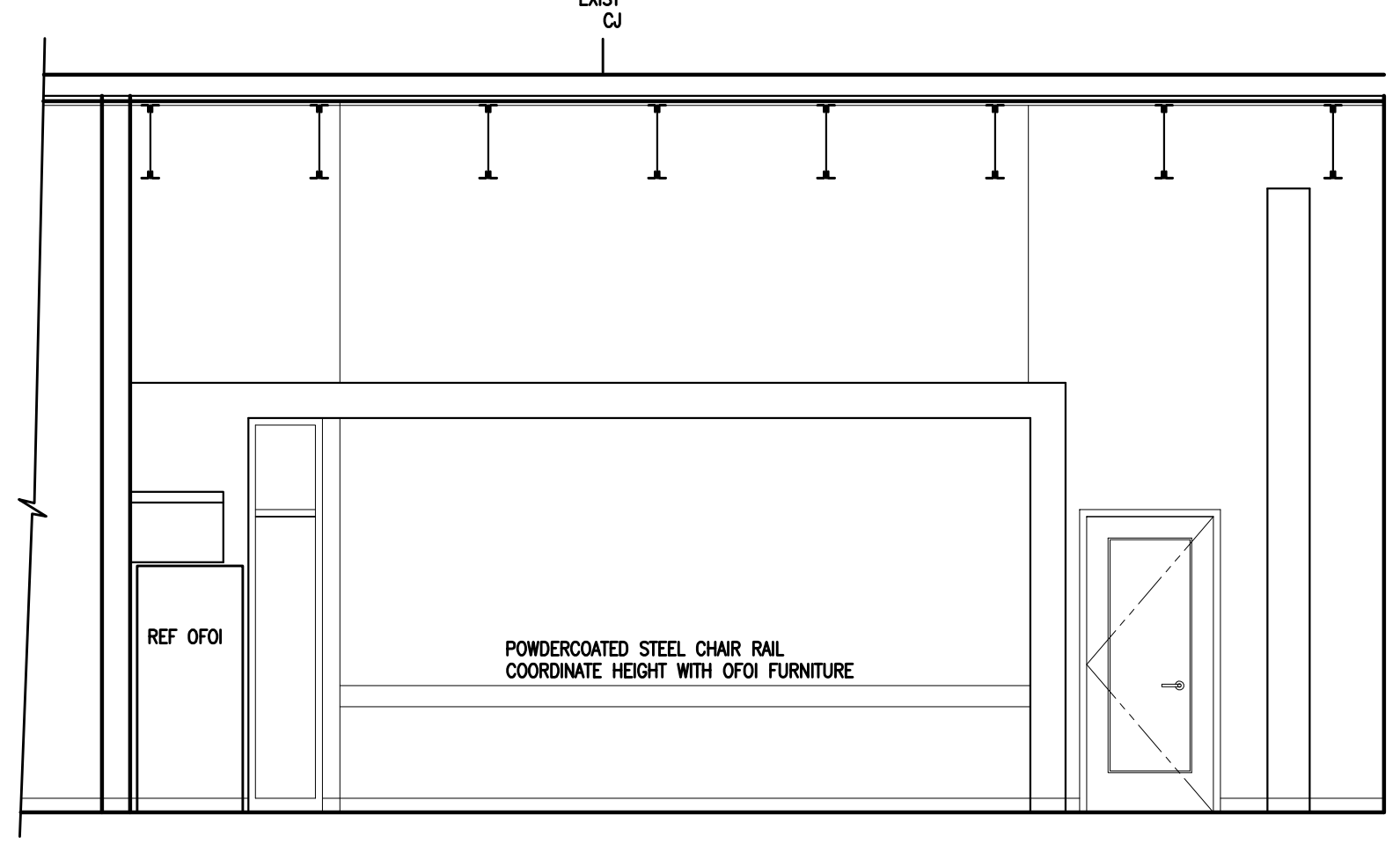

4 NORTH INTERIOR ELEVATION  
1/8"=1'-0"

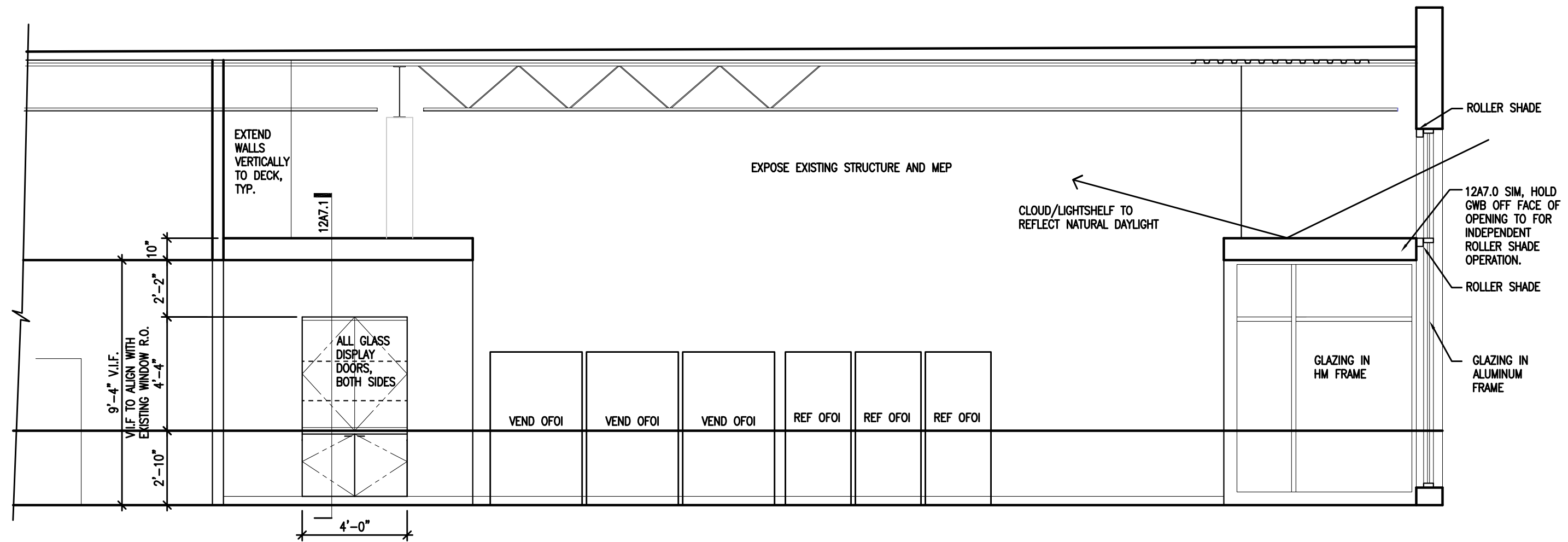

5 EAST INTERIOR ELEVATION  
1/8"=1'-0"

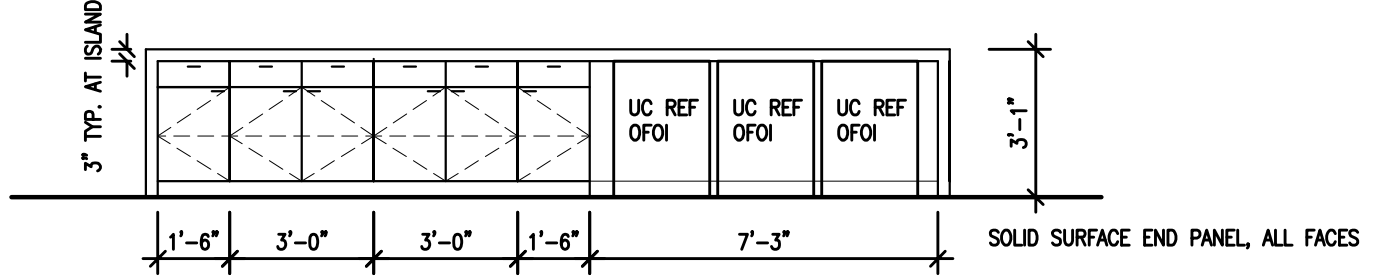

6 ISLAND WEST ELEVATION  
1/8"=1'-0"

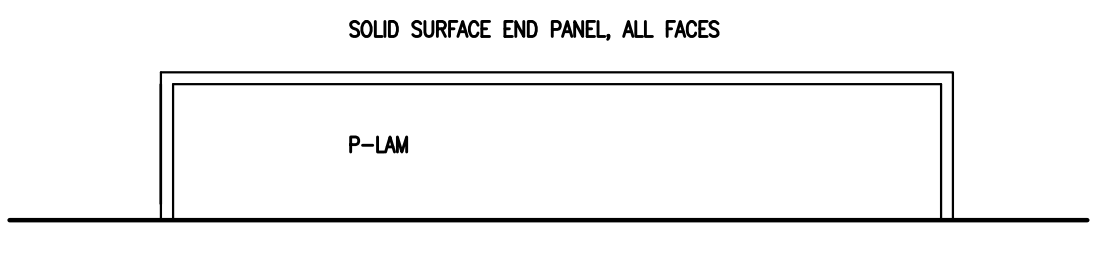

7 ISLAND EAST ELEVATION  
1/8"=1'-0"

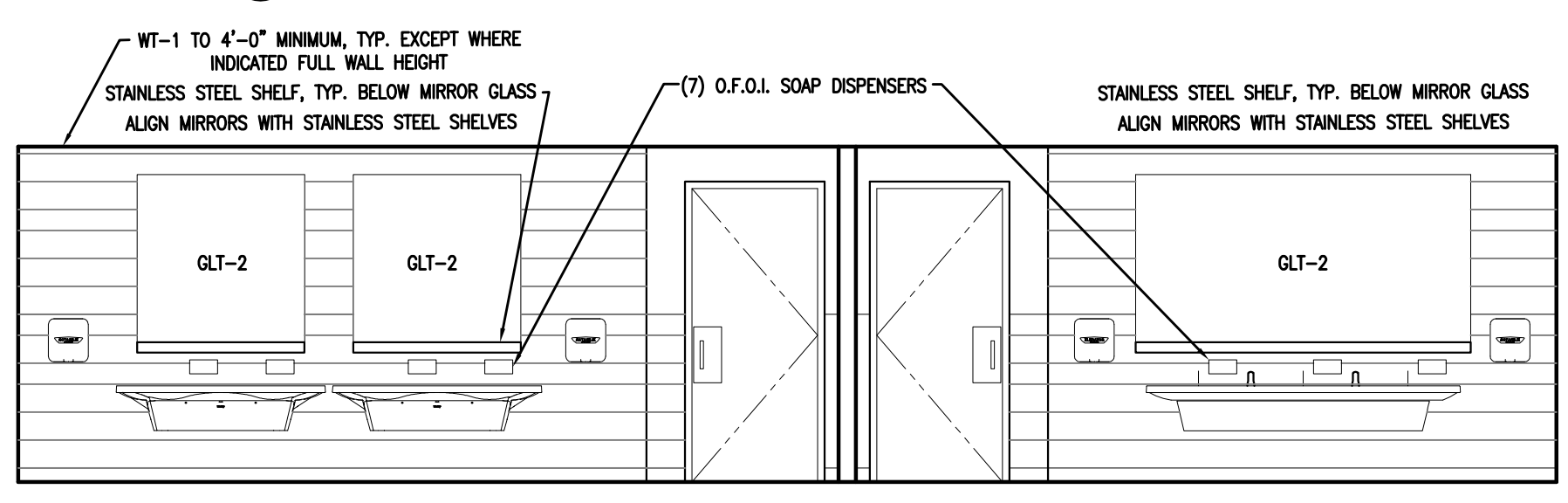

8 WEST INTERIOR ELEVATION  
1/8"=1'-0"

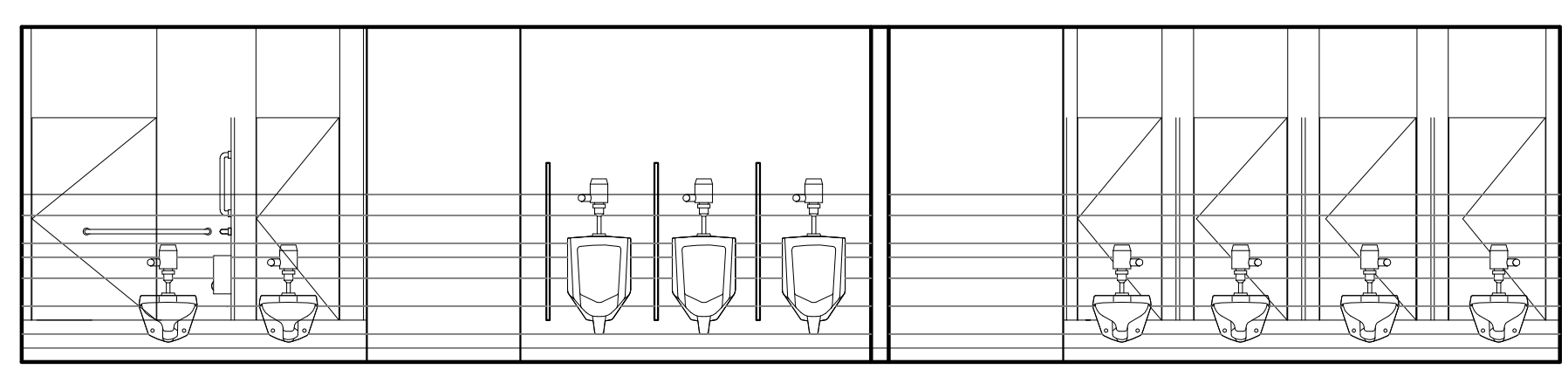

9 EAST INTERIOR ELEVATION  
1/8"=1'-0"

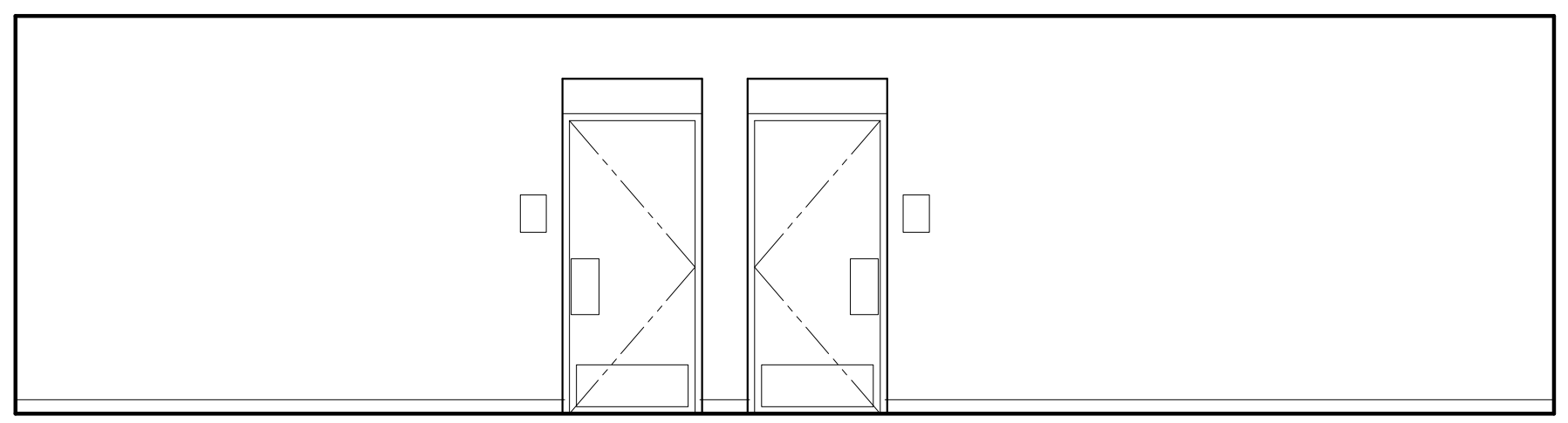

10 EAST CORRIDOR ELEVATION  
1/8"=1'-0"

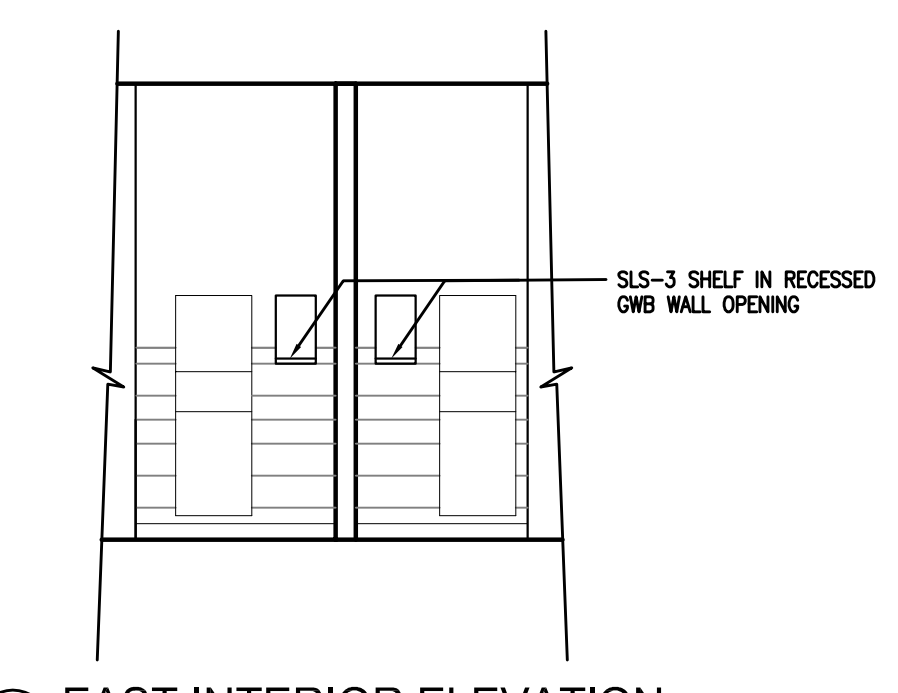

11 EAST INTERIOR ELEVATION  
1/8"=1'-0"

**PROJECT**  
DANE COUNTY JOB CENTER  
RESTROOM EXPANSION  
1819 ABERG AVENUE  
MADISON, WI

**DRAWING**  
INTERIOR ELEVATIONS

**DATE**  
01.11.19

STRUCTURAL SHEET INDEX			
SHEET NUMBER	SHEET NAME	CURRENT REVISION DATE	CURRENT REVISION DESCRIPTION
S001	STRUCTURAL GENERAL NOTES		
S501	STEEL FRAMING DETAILS		

**GENERAL NOTES**

- THE CONTRACTOR IS RESPONSIBLE FOR JOB SITE SAFETY REQUIREMENTS, PROGRAMS AND PRECAUTIONS.
- THE SEOR HAS NO CONTROL OVER, OR CHARGE OF, AND SHALL NOT BE RESPONSIBLE FOR THE MEANS, METHODS, PROCEDURES, TECHNIQUES OF CONSTRUCTION NOR ANY RIGHT OR POWER TO STOP THE WORK.
- THE BUILDING STRUCTURE IS DESIGNED TO FUNCTION AS A COMPLETE SYSTEM, AND HAS NOT BEEN ANALYZED NOR DESIGNED FOR STABILITY DURING CONSTRUCTION. IT IS THE RESPONSIBILITY OF THE CONTRACTOR TO DESIGN AND PROVIDE ADEQUATE TEMPORARY BRACING TO INSURE STABILITY DURING THE CONSTRUCTION PROCESS. ADDITIONALLY, THE CONTRACTOR IS RESPONSIBLE TO INSURE THAT CONSTRUCTION LOADS DO NOT EXCEED THE DESIGN CAPACITY OF THE FRAMING ELEMENTS.
- THE CONTRACTOR IS REQUIRED TO COORDINATE THE STRUCTURAL DRAWINGS WITH THE ARCHITECTURAL, CIVIL, MECHANICAL, ELECTRICAL, AND PLUMBING DRAWINGS, AND TO BRING ANY DISCREPANCIES, INTERFERENCES, DIMENSIONAL INCONSISTENCIES, OR CONCERNS ASSOCIATED WITH THIS COORDINATION TO THE ARCHITECT AND ENGINEERS IMMEDIATELY.
- DO NOT SCALE THE DRAWINGS.
- DETAILS, SECTION CUTS AND NOTES INDICATED ON THESE DRAWINGS APPLY TO ALL SIMILAR CONDITIONS, WHETHER REPEATED OR NOT THROUGHOUT THE DRAWINGS.
- INFORMATION CONTAINED ON THE STRUCTURAL DRAWINGS IS, IN ITSELF, INCOMPLETE AND VOID UNLESS USED IN CONJUNCTION WITH ALL OF THE CONTRACT DOCUMENTS AND ALL SPECIFICATIONS, TRADE PRACTICES, APPLICABLE STANDARDS AND CODES INCORPORATED THEREIN BY REFERENCE.
- THE USE OF THESE DRAWINGS AND SPECIFICATIONS SHALL BE RESTRICTED AND LIMITED TO THE ORIGINAL SITE FOR WHICH THEY WERE PREPARED. ALL REPRODUCTION OR DISTRIBUTION IS EXPRESSLY LIMITED TO SUCH USE. ANY OTHER REPRODUCTION OR REUSE, IN WHOLE OR IN PART, FOR ANY OTHER PURPOSE IS PROHIBITED.

**DESIGN LOADS**

APPLICABLE DESIGN CODE AND REFERENCES

THE CODES AND STANDARDS LISTED HAVE BEEN USED FOR THE DESIGN OF THIS PROJECT. ALL CONSTRUCTION, FABRICATION, AND MATERIALS SHALL CONFORM TO THESE CODES AND STANDARDS.

2015 INTERNATIONAL BUILDING CODE  
 ASCE 7-10 MINIMUM DESIGN LOADS FOR BUILDINGS  
 ACI 318-14 BUILDING CODE REQUIREMENTS FOR STRUCTURAL CONCRETE  
 ACI 530-13 SPECIFICATION FOR MASONRY STRUCTURES  
 NDS-2012 AF&PA NATIONAL DESIGN SPEC FOR WOOD CONSTRUCTION  
 AISC 360-10 SPECIFICATION FOR STRUCTURAL STEEL BUILDINGS  
 AISC 341-10 SEISMIC PROVISIONS FOR STRUCTURAL STEEL BUILDINGS

BUILDING DESIGN CRITERIA  
 BUILDING RISK CATEGORY: II (SEE ASCE 7-10 TABLE 1.5-1)

BUILDING DESIGN LOADS AND DATA

DEAD LOADS  
 ROOF 20 PSF  
 FLOORS NA PSF (SLAB ON GRADE)

FLOOR LIVE LOADS  
 PUBLIC AREAS 100 PSF

ROOF LIVE LOADS  
 TRIB. AREA < 200 SF 20 PSF  
 TRIB. AREA = 600 SF 12 PSF  
 ROOF LIVE LOADS FOR A MEMBER WITH TRIBUTARY BETWEEN 200 SF AND 600 SF MAY BE DETERMINED USING LINEAR INTERPOLATION.

SNOW  
 GROUND SNOW (Pg) 30 PSF  
 SNOW IMPORTANCE FACTOR, (I) 1.0  
 EXPOSURE FACTOR (Ce) 1.0  
 THERMAL FACTOR (Ct) 1.0  
 FLAT ROOF SNOW (P) 21 PSF  
 SEE SNOW DRIFT SURCHARGE PLAN FOR ADDL SNOW LOADS REQUIRED

WIND DESIGN DATA  
 BASIC WIND SPEED 115 MPH  
 WIND IMPORTANCE FACTOR 1.0  
 DIRECTIONALITY FACTOR (Kd) 0.85  
 TOPOGRAPHY FACTOR (Kzt) 1.0  
 WIND EXPOSURE C  
 ENCLOSURE CLASSIFICATION ENCLOSED  
 INTERNAL PRESSURE COEFFICIENT +/- 0.85

ALLOWABLE DEFLECTION CRITERIA  
 EXTERIOR WALLS L/600 WIND (BRICK / MASONRY)

COMPONENTS & CLADDING ULTIMATE WIND DESIGN PRESSURES			
ROOFS	TRIBUTARY AREA = 10 SF	POSITIVE (PSF)	NEGATIVE (PSF)
	ZONE 1	16.0	-33.4
	ZONE 2	16.0	-56
	ZONE 3	16.0	-84.2
	TRIBUTARY AREA = 100 SF	POSITIVE (PSF)	NEGATIVE (PSF)
	ZONE 1	16.0	-30.5
ZONE 2	16.0	-36.2	
ZONE 3	16.0	-36.2	
WALLS	TRIBUTARY AREA = 10 SF	POSITIVE (PSF)	NEGATIVE (PSF)
	ZONE 4	30.5	-33.1
	ZONE 5	30.5	-40.7
	TRIBUTARY AREA = 500 SF	POSITIVE (PSF)	NEGATIVE (PSF)
	ZONE 4	22.9	-25.4
	ZONE 5	22.9	-25.4

**ANCHORAGE TO CONCRETE & MASONRY**

ANCHOR TYPE	CONCRETE			MASONRY	
	SOLID CONCRETE	HOLLOW CORE PLANK	CONC OVER MTL DECK	GROUT FILLED CMU	HOLLOW CMU
<b>ADHESIVE W/ THREADED ROD</b>	HILTI-HY 200 W/ HAS-E THREADED ROD	HILTI-HY 70 W/ HAS-E ROD & MESH SLEEVE	N/A	HILTI-HY 70 W/ HAS-E THREADED ROD	HILTI-HY 70 W/ HAS-E ROD IN HIT-SC SLEEVE OR HIT-IC INSERT
<b>ADHESIVE W/ REBAR</b>	HILTI HIT-RE V3 ADHESIVE W/ GR 60 REBAR	N/A	N/A	N/A	N/A
<b>EXPANSION ANCHOR</b>	HILTI KWIK BOLT TZ	N/A	HILTI KWIK BOLT TZ	HILTI KWIK BOLT TZ	N/A
<b>HEAVY DUTY SCREW ANCHOR</b>	SIMPSON TITEN HD OR HILTI KWIK HUS	N/A	SIMPSON TITEN HD OR HILTI KWIK HUS	SIMPSON TITEN HD OR HILTI KWIK HUS	SIMPSON TITEN HD
<b>LIGHT DUTY SCREW ANCHOR</b>	SIMPSON TITEN	SIMPSON TITEN	N/A	SIMPSON TITEN	SIMPSON TITEN
<b>POWDER ACTUATED FASTENERS</b>	SIMPSON PD OR HILTI X-U	SIMPSON PD OR HILTI X-U	SIMPSON PD OR HILTI X-U	N/A	N/A

**NOTES:**

- THE ABOVE CHART INDICATES BASIS OF DESIGN FOR ANCHORAGE, UNLESS NOTED OTHERWISE IN THE PLANS OR DETAILS.
- ALTERNATIVE ANCHORAGE (OTHER THAN DUE TO WEATHER) SHALL BE EVALUATED AT THE COST OF THE CONTRACTOR AND SUBMITTED W/ ENGINEERING CALCULATIONS. CALCULATIONS MUST CONSIDER CONCRETE EDGE AND END DISTANCES, CRACKED CONCRETE AND CONTAIN A CURRENT CODE EVALUATION REPORT.
- ALL ANCHORAGE AND FASTENINGS SHALL BE INSTALLED PER THE MANUFACTURERS SPECIFICATIONS.
- ADHESIVE ANCHORS SHALL BE INSTALLED WITHIN THEIR RECOMMENDED TEMPERATURE RANGE AND UNDER APPROPRIATE WEATHER CONDITIONS. IF SCHEDULE DICTATES ALTERNATIVE ADHESIVE FOR COLD OR HOT WEATHER, PRODUCT DATA MUST BE SUBMITTED TO THE SER FOR APPROVAL AND COMMENT.
- SPACING, END DISTANCE AND EDGE DISTANCE OF ANCHORAGE SHALL BE IN ACCORDANCE WITH MANUFACTURERS' RECOMMENDATIONS. PAY PARTICULAR ATTENTION TO AVOIDING HEAD AND BED JOINTS WHEN REQUIRED IN MASONRY.

**STRUCTURAL STEEL NOTES**

- SEE SPECIFICATION DIVISION 05 SECTION OR REQUIREMENTS IN ADDITION TO THOSE LISTED BELOW.
- PROVIDE NEW MATERIAL CONFORMING TO THE FOLLOWING REQUIREMENTS FOR ALL STRUCTURAL STEEL:
 

WIDE FLANGE SHAPES (ASTM A992)	Fy = 50 ksi; Fu = 65 ksi
M, S, HP, C, MC, AND L SHAPES (ASTM A36)	Fy = 36 ksi; Fu = 58 ksi
RECTANGULAR HSS SHAPES (ASTM A500-B)	Fy = 46 ksi; Fu = 58 ksi
ROUND HSS SHAPES (ASTM A500-B)	Fy = 42 ksi; Fu = 58 ksi
CARBON STEEL PIPE (ASTM A53-B)	Fy = 35 ksi; Fu = 60 ksi
PLATES AND BARS (ASTM A36)	Fy = 36 ksi; Fu = 58 ksi
- DETAIL, FABRICATE AND ERECT STRUCTURAL STEEL IN CONFORMANCE WITH THE AISC SPECIFICATIONS AND CODES INDICATED.
- PERFORM ALL WELDING USING CERTIFIED WELDERS AND IN ACCORDANCE WITH THE AWS "STRUCTURAL WELDING CODE - STEEL".
- SUBMIT SHOP DRAWINGS TO THE ARCHITECT/ENGINEER FOR REVIEW. SHOW SHOP FABRICATION DETAILS, FIELD ASSEMBLY DETAILS, AND ERECTION DIAGRAMS FOR ALL STRUCTURAL STEEL. SCHEDULE SUBMISSIONS TO ALLOW ADEQUATE TIME FOR REVIEW PRIOR TO FABRICATION.
- DETAIL ALL BEAMS FRAMING INTO CONCRETE WALLS, BEAMS OR COLUMNS TO ALLOW FOR HORIZONTAL FIELD TOLERANCES AND THERMAL MOVEMENT. PROVIDE CONNECTION DETAILS REQUIRED BY THE SPECIFIC CONSTRUCTION SEQUENCES.
- REFER TO THE ARCHITECTURAL DRAWINGS FOR THE REQUIRED FIRE RATINGS AND UL ASSEMBLY NUMBERS
- DO NOT FIELD CUT ANY STRUCTURAL STEEL UNLESS REVIEWED AND APPROVED IN WRITING BY THE EOR. CLEARLY INDICATE ALL STEEL MEMBER OPENINGS REQUIRED ON THE SHOP DRAWINGS. ALL COSTS FOR PROVIDING PENETRATIONS IN THE FIELD, INCLUDING MEMBER REINFORCING, IS THE RESPONSIBILITY OF THE CONTRACTOR.
- ERECTION PROCEDURES, SEQUENCES AND COORDINATION OF WORK WITH OTHER TRADES IS THE RESPONSIBILITY OF THE CONTRACTOR. PROVIDE ANY ADDITIONAL STEEL REQUIRED FOR ERECTION PURPOSES AT NO COST TO THE OWNER. REMOVE THIS ADDITIONAL STEEL UNLESS DIRECTED OTHERWISE BY THE OWNER IN WRITING.
- PROVIDE TEMPORARY BRACING AND SHORING AS REQUIRED FOR THE SAFETY, STABILITY AND ALIGNMENT OF THE STRUCTURE. LEAVE TEMPORARY BRACING IN PLACE UNTIL THE PERMANENT STRUCTURAL LATERAL LOAD RESISTING SYSTEM IS COMPLETE, INCLUDING FLOOR AND ROOF DIAPHRAGMS. PERFORM FINAL BOLTING AND WELDING ONLY ON THOSE PORTIONS OF THE STRUCTURE THAT HAVE BEEN ALIGNED AND PLUMBED WITHIN THE SPECIFIED TOLERANCES.
- GROUT COLUMN BASE PLATES AFTER BUILDING FRAME HAS BEEN ALIGNED AND PLUMBED, AND PRIOR TO PLACEMENT OF CONCRETE FLOOR SYSTEMS (CIP CONCRETE SLABS, SLABS ON STEEL DECK, PRECAST, ETC). GROUT BEAM BEARING PLATES AFTER BEAM ALIGNMENT AND PRIOR TO PLACEMENT OF FLOOR SYSTEMS. MINIMUM GROUT STRENGTH EQUALS THE HIGHER OF 6000 PSI OR THE INDICATED COMPRESSIVE STRENGTH OF THE CONCRETE THE COLUMN IS BEARING ON.
- ALL STRUCTURAL STEEL IN DIRECT CONTACT WITH FIRE RETARDANT TREATED (FRT) OR PRESERVATIVE TREATED LUMBER MUST BE WRAPPED WITH A BARRIER MEMBRANE (GRACE VYCOR DECK PROTECTOR OR EQUAL). ALL FASTENERS ATTACHING TREATED LUMBER TO STEEL MUST BE GALVANIZED.
- LONG SLOTTED HOLES ARE PERMITTED ONLY WHERE SHOWN IN THE CONSTRUCTION DOCUMENTS. IF SHOWN, 5/16" PLATE WASHERS ARE REQUIRED AT ALL LOCATIONS. ALTERNATIVELY, A CONTINUOUS BAR BETWEEN LONG SLOTTED HOLES MAY BE USED.

**COLD FORMED STEEL FRAMING**

- MATERIAL SPECIFICATIONS

COLD FORMED STUDS, JOISTS, AND TRACKS ASTM C955 & ASTM A1003  
 Fy=50 KSI, Fu=65 KSI (16 GAGE AND THICKER)  
 Fy=33 KSI, Fu=45 KSI (18 GAGE AND THINNER)
- GALVANIZED FINISHES: ALL COLD FORMED MEMBERS SHALL BE FORMED OF STEEL HAVING THE FOLLOWING GALVANIZED COATING MEETING THE REQUIREMENTS OF ASTM A653: STUDS, JOISTS, TRACK, BRIDGING, AND ACCESSORIES: G-60 GALVANIZED FINISH UNO ALL MEMBERS EXPOSED TO WEATHER: G90 GALVANIZED FINISH. JOIST RITE JOISTS : G90 GALVANIZED FINISH.
- COLD FORMED STEEL STUDS (S) AND TRACKS (T) SHALL CONFORM TO THE STEEL STUD MANUFACTURERS ASSOCIATION (SSMA) STANDARDS.
- ALL COLD FORMED STEEL FASTENERS SHOWN ON DRAWINGS ARE BY MARINO. SUBSTITUTIONS FOR THESE ITEMS SHALL BE SUBMITTED TO THE STRUCTURAL ENGINEER OF RECORD FOR APPROVAL PRIOR TO CONSTRUCTION.
- HEAVIER GAUGE MATERIAL MAY BE SUBSTITUTED BY CONTRACTOR IF DESIRED.
- WHEN PROVIDED, FACTORY PUNCH-OUTS WILL BE LOCATED ALONG THE CENTERLINE OF THE WEBS OF MEMBERS AND WILL HAVE A CENTER-TO-CENTER SPACING OF 24". PUNCH-OUTS WILL HAVE A MAXIMUM WIDTH = HALF THE MEMBER DEPTH (d/2) OR 2-1/2", WHICHEVER IS LESS, AND A MAXIMUM LENGTH = 4-1/2". THE MINIMUM DISTANCE BETWEEN THE END OF A MEMBER AND THE NEAREST EDGE OF THE WEB PUNCH-OUT SHALL BE 10".
- THE CONTRACTOR SHALL SUBMIT COLD FORMED STEEL SHOP DRAWINGS TO STRUCTURAL ENGINEER OF RECORD FOR APPROVAL PRIOR TO CONSTRUCTION. SHOP DRAWING SHALL INCLUDE:
  - PLANS INDICATING MEMBER SIZES AND LOCATIONS
  - SECTIONS INDICATING COLD FORMED STEEL MEMBER CONNECTIONS
- PROVIDE TOP AND BOTTOM TRACKS AT ALL WALLS. ALL TRACKS SHALL BE THE SAME GAUGE AS THE STUDS FRAMING INTO THEM UNLESS NOTED OTHERWISE.
 

EXCEPTION: ALL TRACKS FASTENED INTO FOUNDATION SHALL BE 600S125-68 UNO
- FIELD CUTTING OF COLD FORMED STEEL SHALL BE DONE BY SAWING OR SHEARING. TORCH CUTTING OF COLD FORMED MEMBERS IS NOT ACCEPTABLE.
- NO NOTCHING OR COPING OF COLD FORMED MEMBERS IS ALLOWED UNLESS APPROVED BY THE STRUCTURAL ENGINEER OF RECORD.
- ALL HEADERS AND BEAMS SHALL BE CONSTRUCTED WITH UNPUNCHED MATERIAL.
- SPlicing OF WALL STUDS MUST CONFORM TO THE DETAILS SHOWN IN THIS DRAWING SET.
- ALL BEARING AND SHEAR WALLS SHALL HAVE BRIDGING AT 48" OC MAX. STUD SUPPLIER TO . SUBMIT BRIDGING WITH SHOP DRAWINGS FOR REVIEW.
- ANY COLD FORMED STEEL CONNECTIONS NOT SPECIFICALLY DETAILED ON THESE DRAWINGS SHALL BE DESIGNED & DETAILED BY THE COLD FORMED STEEL ENGINEER.
- MINIMUM SCREW SPACING SHALL BE 3d  
 MINIMUM SCREW EDGE SPACING SHALL BE 1.5d.
- CFS JOIST WEB KNOCKOUTS SHALL NOT OCCUR A DISTANCE LESS THAN THE JOIST BEARING LENGTH + 4" FROM END OF JOIST.
- THICKNESS OF WELDS TO COLD FORMED STEEL SHALL EQUAL THE THICKNESS OF THE MEMBER BEING WELDED.

**DEFERRED SUBMITTALS**

- IN ACCORDANCE WITH THE IBC CHAPTER 1, SPECIALTY ITEMS, PRE-ENGINEERED COMPONENTS, AND DESIGN BUILD ELEMENTS MAY BE SUBMITTED FOR APPROVAL BY THE ENGINEER OF RECORD AND THE BUILDING OFFICIAL BY DEFERRED SUBMITTAL. SUCH ITEMS ARE DEFINED AS THOSE SPECIFIED IN CONSTRUCTION DOCUMENTS BUT WHICH REQUIRE DESIGN BY THE MANUFACTURER, SUPPLIER OR INSTALLER.
- DEFERRED SUBMITTALS ARE REQUIRED FOR THE FOLLOWING:
  - COLD FORMED STEEL FRAMING
- SUBMITTALS SHALL INCLUDE:
  - CALCULATIONS, PREPARED AND SEALED BY AN APPROPRIATELY REGISTERED ENGINEER (THE "SPECIALTY ENGINEER").
  - DIAGRAM PREPARED AND SEALED BY THE SPECIALTY ENGINEER, SHOWING LOAD MAGNITUDES AND LOCATIONS - SEPARATED INTO DEAD, LIVE, WIND AND/OR SEISMIC COMPONENTS - THAT ARE APPLIED TO THE PRIMARY STRUCTURE.
  - ERECTION OR DESIGN DRAWINGS BEARING THE SPECIALTY ENGINEER'S SEAL AND THE ARCHITECT'S STAMP INDICATING HIS REVIEW.
- SUBMIT A SEALED COPY FOR THE STRUCTURAL ENGINEER OF RECORD'S FILE, AND ADDITIONAL COPIES AS ARE NECESSARY FOR THE BUILDING DEPARTMENT. SUBMITTALS CONTAINING EXCEPTIONS, CORRECTIONS, OR OTHER REVIEW COMMENTS ARE NOT ACCEPTABLE FOR SUBMITTAL TO THE BUILDING DEPARTMENT.
- THE STRUCTURAL ENGINEER OF RECORD'S REVIEW IS STRICTLY LIMITED TO THE FOLLOWING:
  - THE DRAWINGS AND CALCULATIONS ARE PROPERLY SEALED.
  - THE LOAD CRITERIA IS CONSISTENT WITH THE CONTRACT DOCUMENTS AND UNIFORM BUILDING CODE REQUIREMENTS.
  - THE CONNECTIONS TO THE PRIMARY STRUCTURE ARE CONSISTENT WITH THE PRIMARY DESIGN.
  - THE BASE STRUCTURE IS CAPABLE OF SUPPORTING THE IMPOSED LOADS.
- IF THE LOADS IMPOSED ON THE STRUCTURE EXCEED THE LOAD ALLOWANCE PROVIDED THE STRUCTURAL ENGINEER OF RECORD WILL REJECT THE SUBMITTAL. ONLY AT THE OWNER'S WRITTEN DIRECTION WILL MODIFICATIONS TO THE BASE STRUCTURE TO ACCOMMODATE THE SPECIALTY ITEMS) BE MADE BY THE ENGINEER OF RECORD. DEFERRED SUBMITTAL ITEMS SHALL NOT BE INSTALLED UNTIL THE ENGINEER OF RECORD AND THE BUILDING OFFICIAL HAVE APPROVED THE SUBMITTAL DOCUMENTS.

Architecture  
 Planning

Dorschner/Associates, Inc.  
 849 E. Washington Ave., Ste 112  
 Madison, Wisconsin 53703

**ISSUED**



725 HEARTLAND TRAIL, SUITE 203  
 MADISON, WI 53717  
 (608) 658-0436  
 www.strategicstructural.com  
 SSD Project No. 180218

**PROJECT**  
 DANE COUNTY JOB CENTER  
 RESTROOM EXPANSION  
 1819 ABERG AVENUE  
 MADISON, WI

**DRAWING**  
 STRUCTURAL GENERAL  
 NOTES

**DATE**  
 1.11.19

**S001**

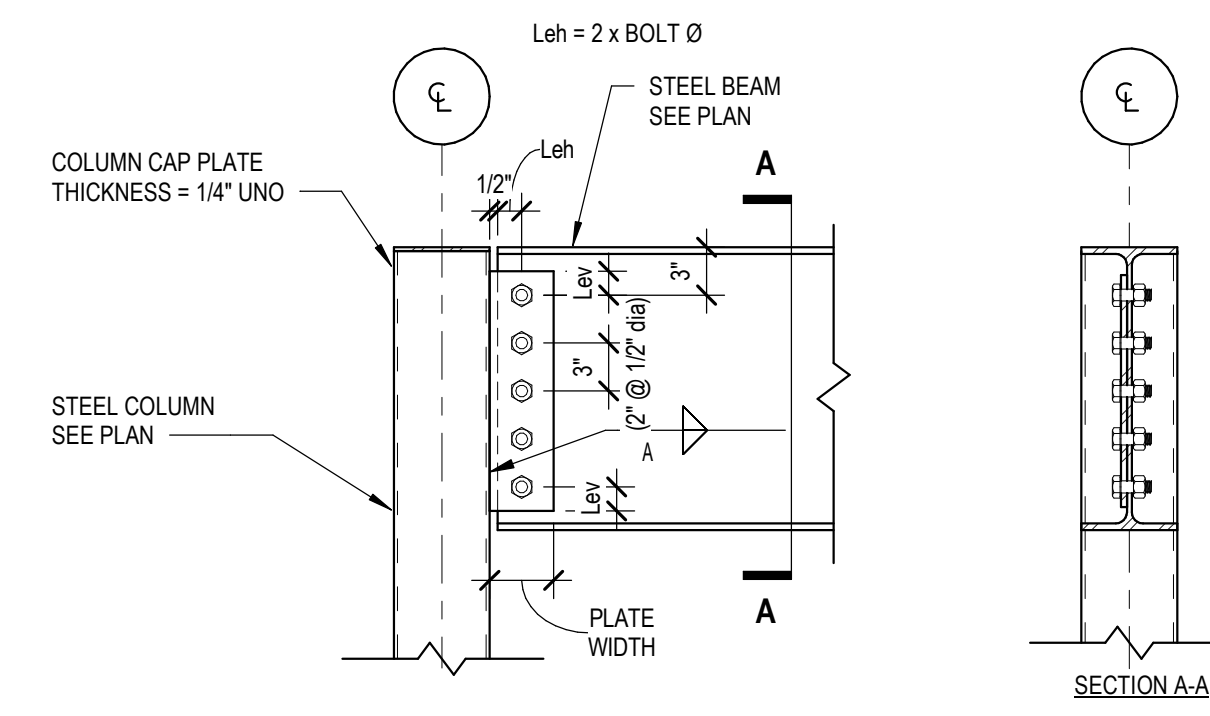
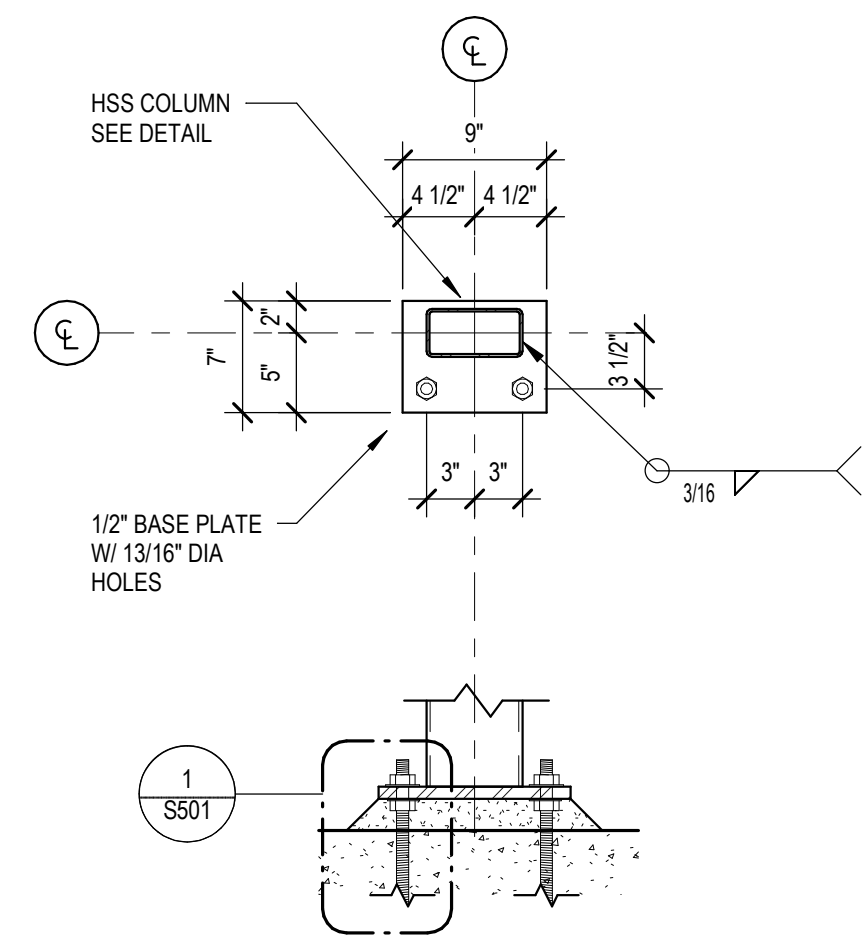
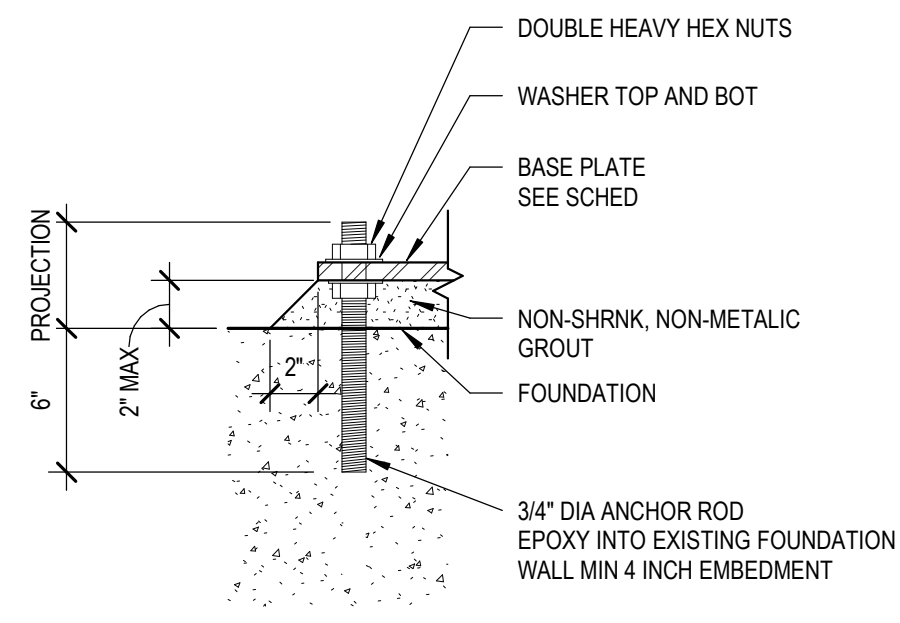

SINGLE PLATE CONNECTION SCHEDULE						
BEAM SIZE	BOLT QTY	BOLT TYPE	PLATE THICKNESS	WELD THICKNESS	Lev	PLATE WIDTH
W6	2	1/2 Ø A325-N	1/4"	3/16"	1 1/4"	3 1/2"
W8, W10	2	3/4" Ø A325-N				

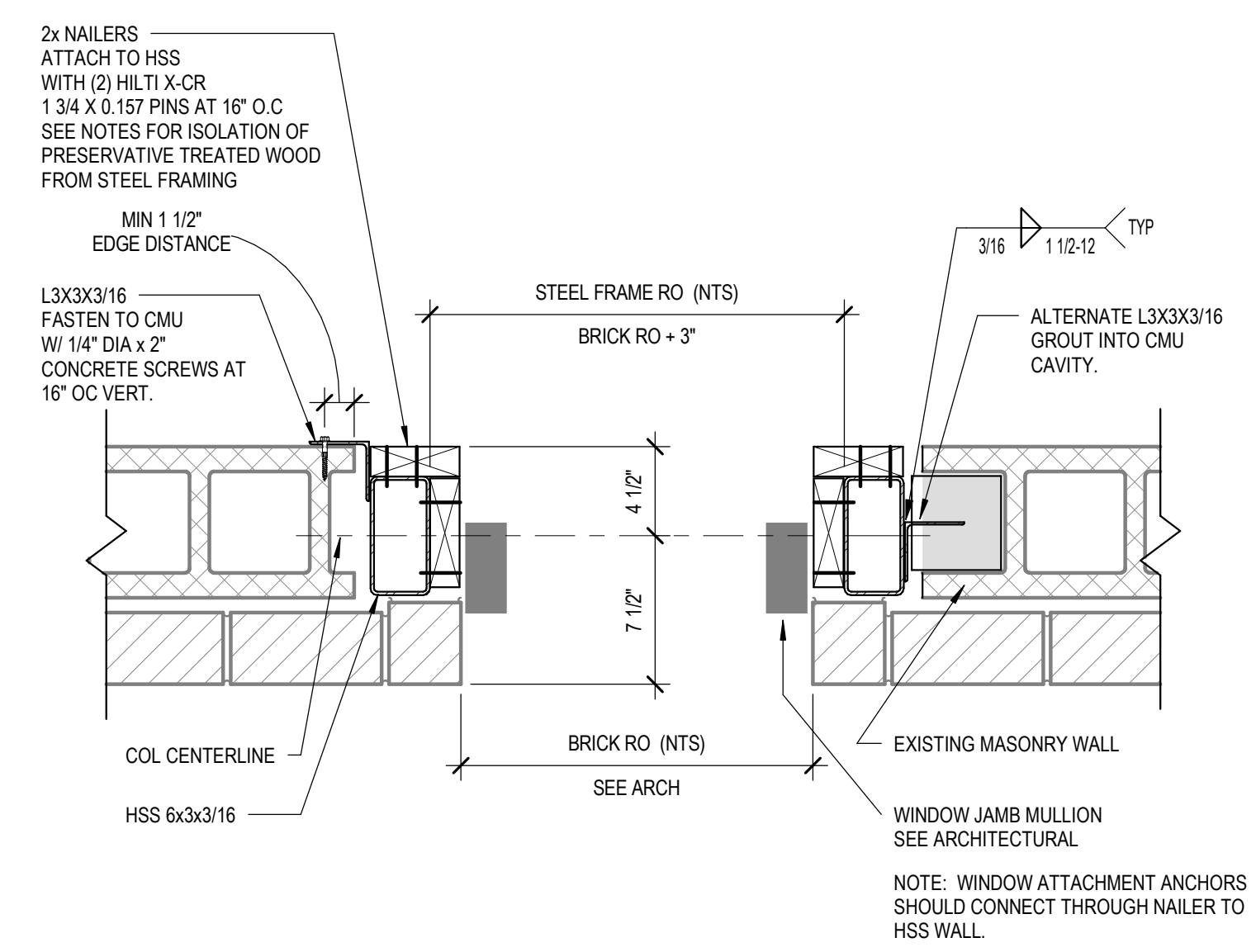

1 ANCHOR RODS  
1 1/2" = 1'-0"

2 BASE PLATES  
1" = 1'-0"

3 STEEL BEAM CONNECTION TO HSS COLUMN  
1" = 1'-0"

4 SECTION AT JAMB  
1 1/2" = 1'-0"

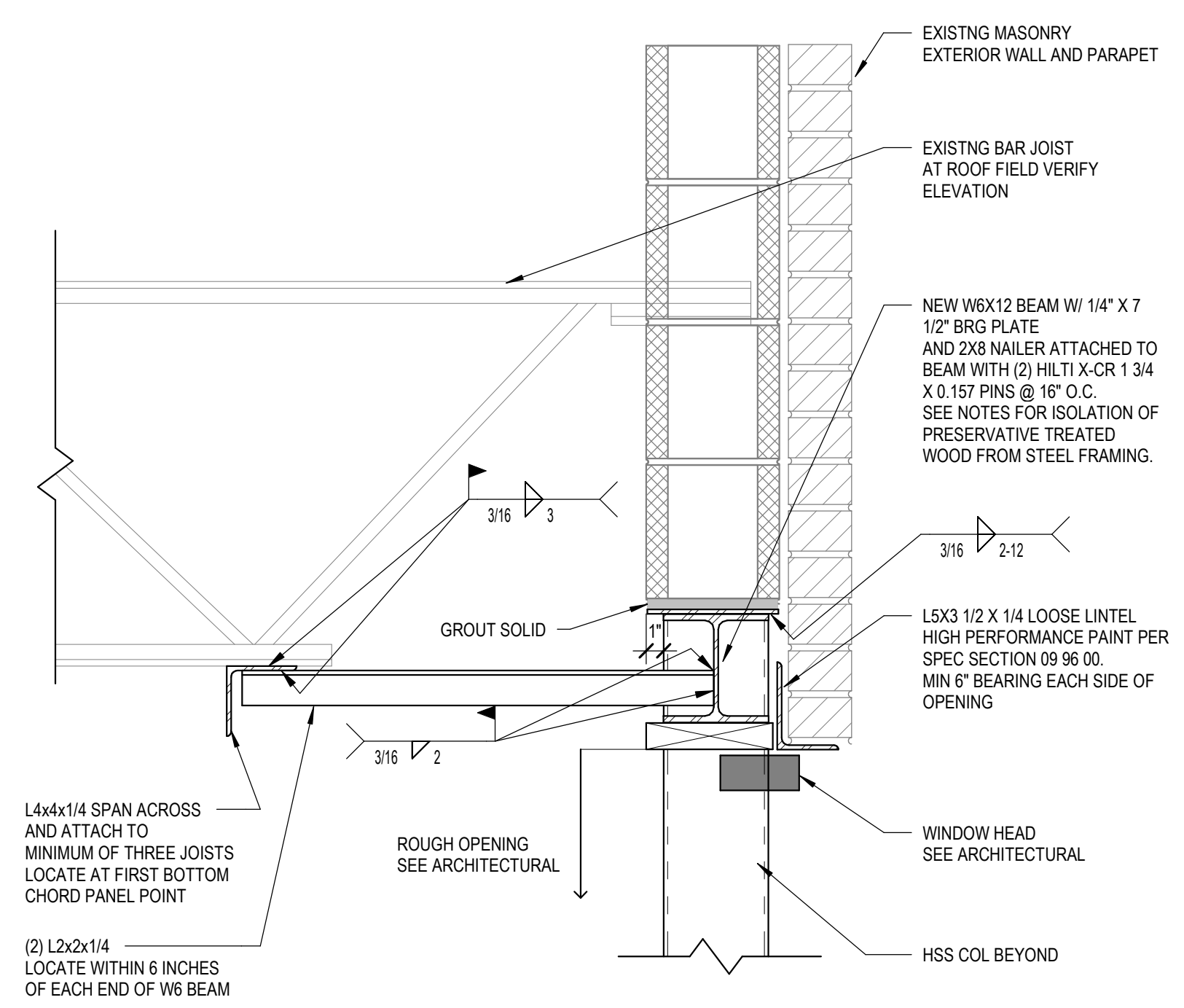
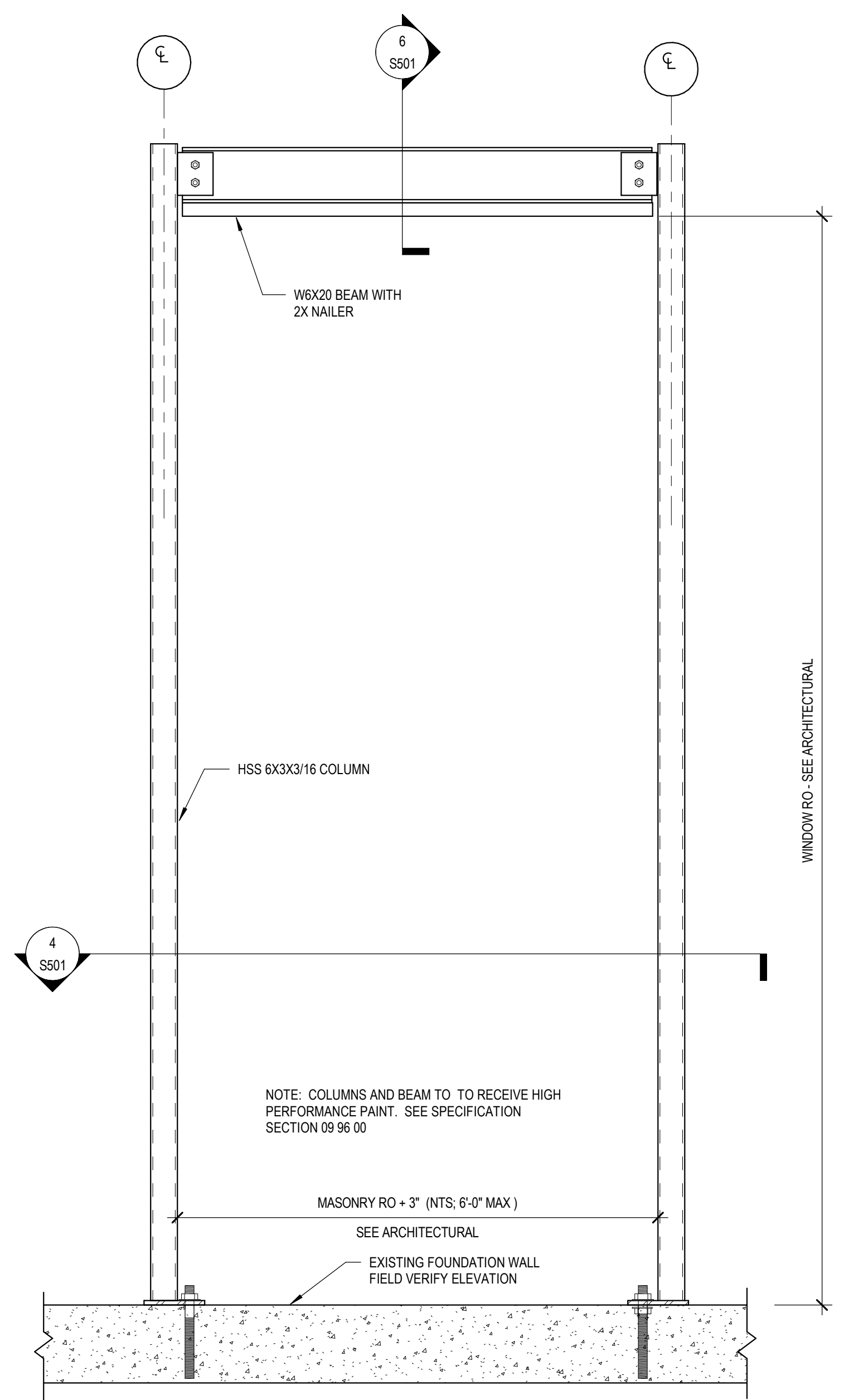

5 WINDOW FRAME AT EXTERIOR WALL  
NTS

6 SECTION AT HEAD OF OPENING  
1 1/2" = 1'-0"

© Strategic Structural Design, LLC 2018  
All rights reserved. No part of this document may be reproduced or transmitted in any form without prior written authorization from Strategic Structural Design, LLC.

725 HEARTLAND TRAIL, SUITE 203  
MADISON, WI 53717  
(608) 658-0436  
www.strategicstructural.com  
SSD Project No. 180218

**PROJECT**  
DANE COUNTY JOB CENTER  
RESTROOM EXPANSION  
1819 ABERG AVENUE  
MADISON, WI

**DRAWING**  
STEEL FRAMING DETAILS

**DATE**  
1.11.19

S501



Architecture  
Planning

Dorschner Associates, Inc.  
848 E. Washington Ave., Ste 112  
Madison, Wisconsin 53703

**SPD**  
SELECT PLUMBING DESIGN, LLC

4564 EVERGREEN ROAD  
MIDDLETON, WI 53562

(608) 836-9674

Project No. 17-002

**ISSUED**

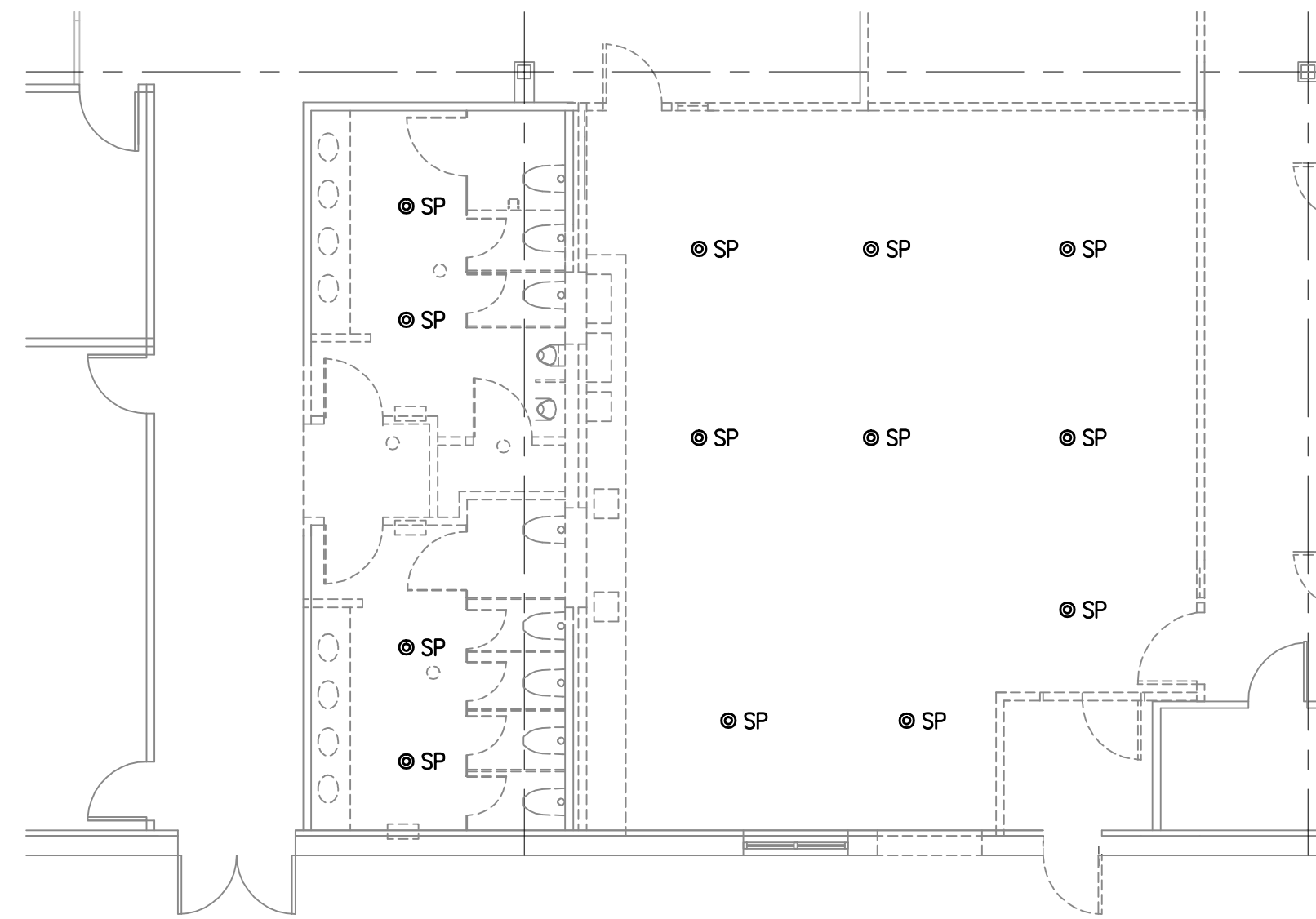

● SP = EXISTING SPRINKLERS (APPROXIMATE LOCATIONS)

1 PARTIAL FIRST FLOOR PLAN – EXISTING SPRINKLER HEADS  
SCALE: 1/8" = 1'-0"

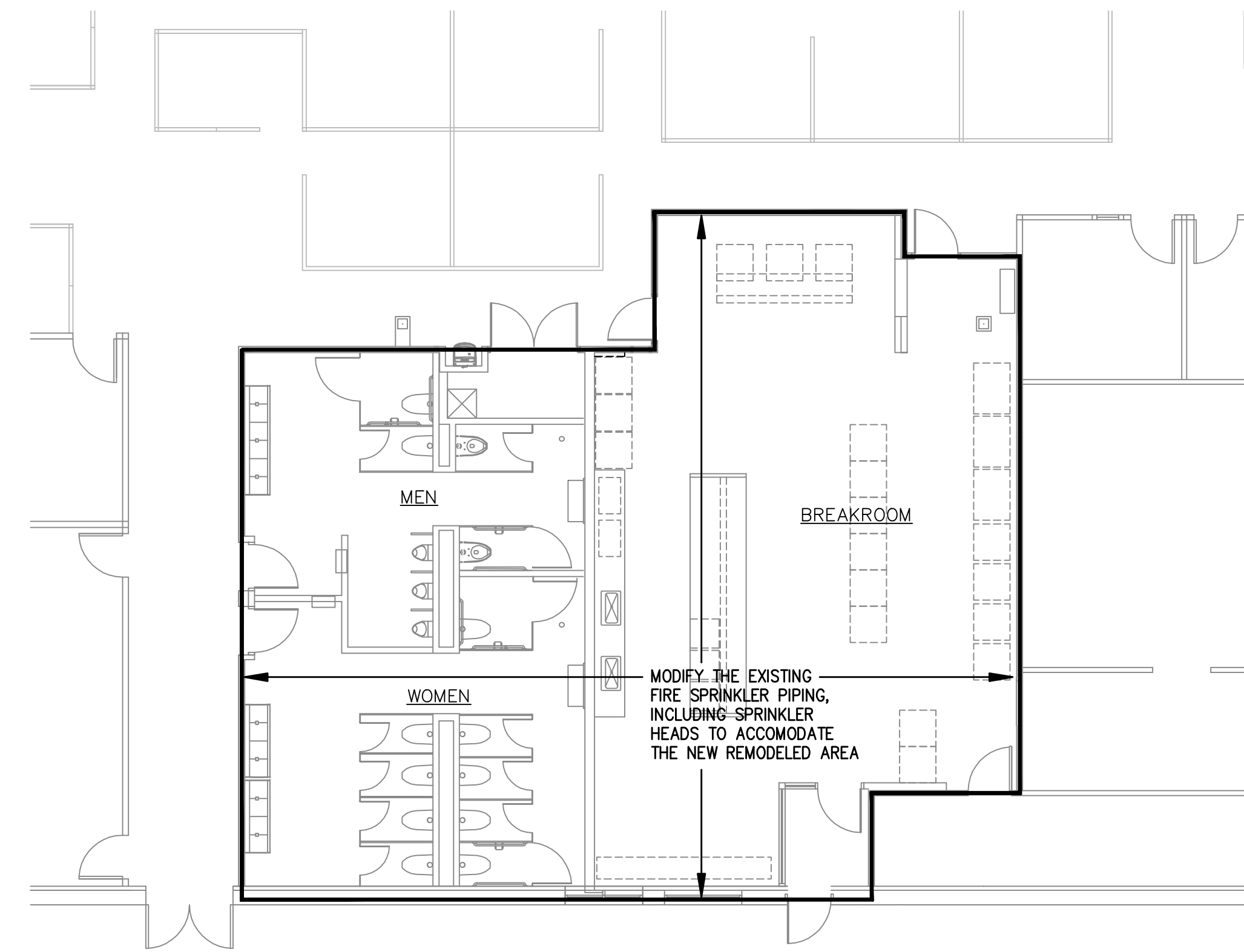

2 PARTIAL FIRST FLOOR FIRE PROTECTION PLAN  
SCALE: 1/8" = 1'-0"

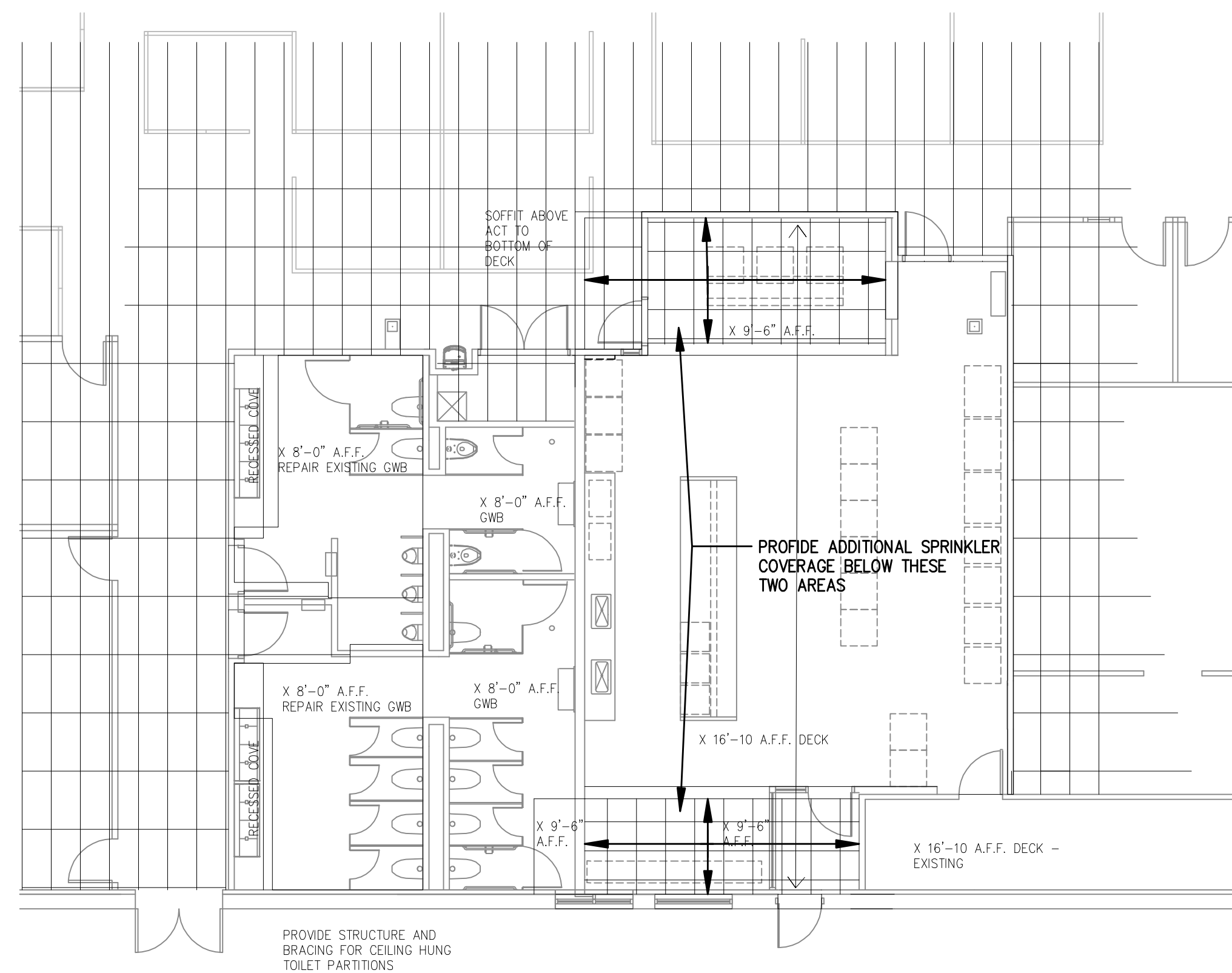

3 PARTIAL FIRST FLOOR REFLECTED CEILING PLAN  
SCALE: 1/8" = 1'-0"

**GENERAL PLUMBING NOTES:**

1. VERIFY TWO LOCATION OF EXISTING SPRINKLER HEADS AND SPRINKLER PIPING.
2. REFER TO ARCHITECTURAL DRAWINGS FOR NEW CEILING LAYOUT AND CEILING TYPES.

**PROJECT**  
DANE COUNTY JOB CENTER  
RESTROOM EXPANSION  
1819 ABERG AVENUE  
MADISON, WI  
- RFB # 318045 -

**DRAWING**

PARTIAL FIRST  
FLOOR FIRE  
PROTECTION PLANS

**DATE**

01/11/19

**FP1.0**

Architecture  
Planning

Dorschner Associates, Inc.  
848 E. Washington Ave., Ste 112  
Madison, Wisconsin 53703

**SPD**  
SELECT PLUMBING DESIGN, LLC

4564 EVERGREEN ROAD  
MIDDLETON, WI 53562

(808) 836-9674

Project No. 17-002

ISSUED

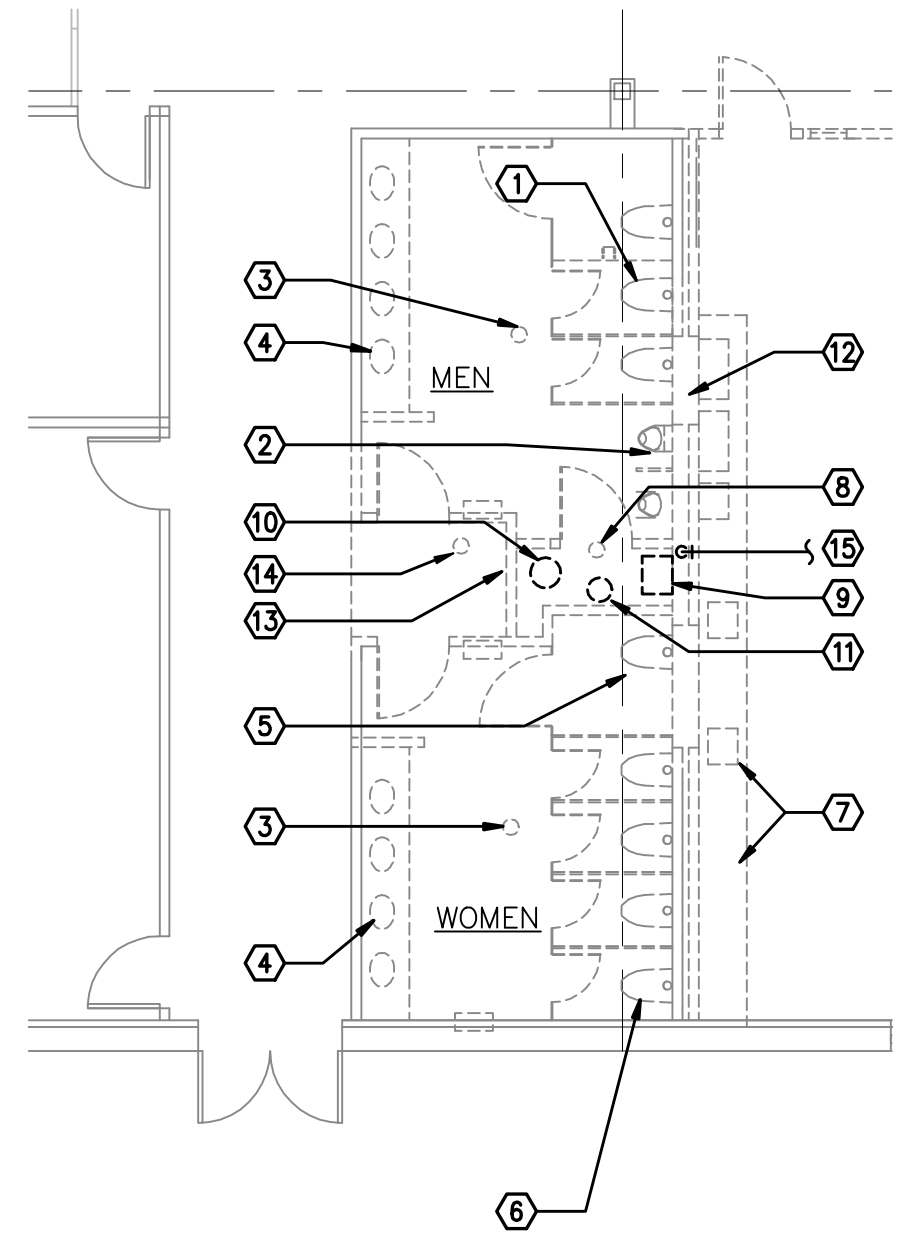

**3** PLUMBING DEMO PLAN  
P1.0 SCALE: 1/8" = 1'-0"

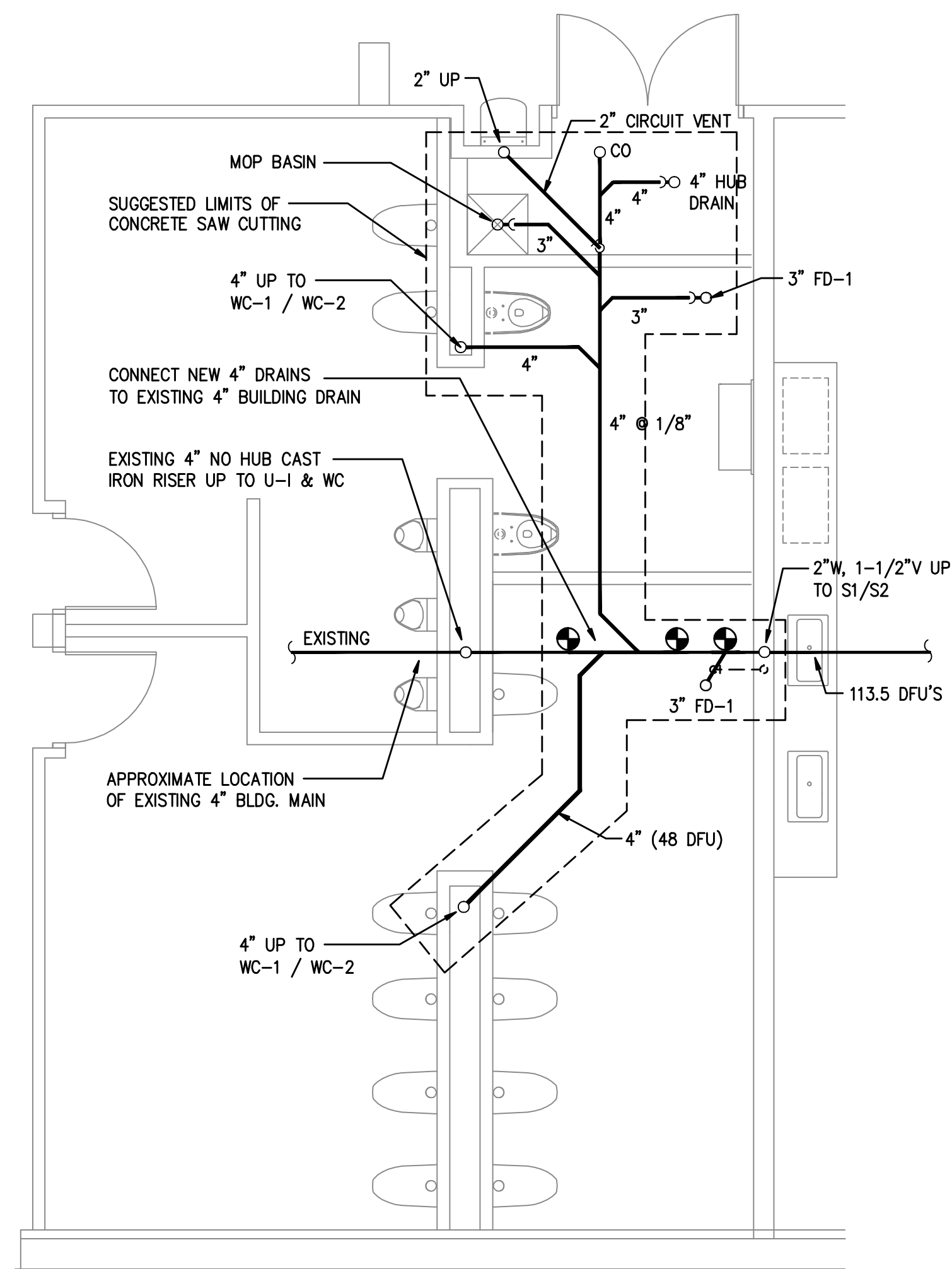

**2** PARTIAL UNDER SLAB PLUMBING PLAN  
P1.0 SCALE: 1/4" = 1'-0"

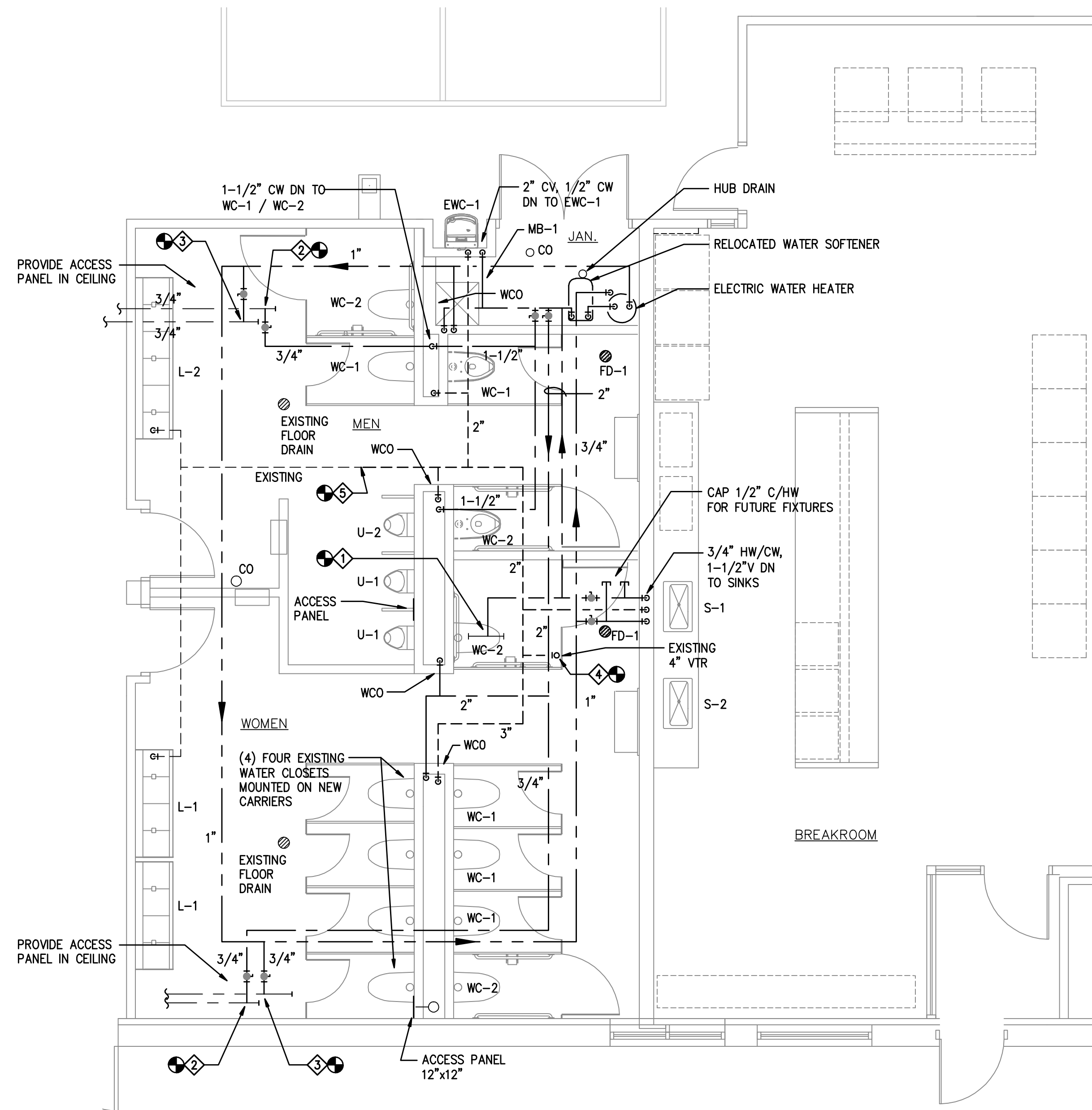

**1** PARTIAL FIRST FLOOR PLUMBING PLAN  
P1.0 SCALE: 1/4" = 1'-0"

- DEMOLITION NOTES:**
- REMOVE THREE (3) WALL HUNG WATER CLOSETS WITHIN MENS TOILET ROOM, INCLUDING FLUSH VALVES.
  - REMOVE TWO (2) WALL HUNG URINALS WITHIN MENS TOILET ROOM, INCLUDING FLUSH VALVES.
  - FLOOR DRAIN TO REMAIN.
  - REMOVE FOUR (4) COUNTER MOUNTED LAVATORIES WITHIN MENS AND WOMENS TOILET ROOMS, INCLUDING FAUCETS, P-TRAPS, SUPPLIES AND STOPS.
  - REMOVE ONE (1) WALL HUNG WATER CLOSET WITHIN WOMENS TOILET ROOM, INCLUDING FLUSH VALVES.
  - REMOVE FOUR (4) WATER CLOSETS W/FLUSH VALVES AND RE-INSTALL ON NEW BACK TO BACK CLOSET CARRIERS.
  - REMOVE TWO (2) COUNTER MOUNTED STAINLESS STEEL SINK WITHIN BREAKROOM, INCLUDING GARBAGE DISPOSAL, FAUCET, P-TRAP, SUPPLIES AND STOPS. REMOVE ALL RELATED WATER, WASTE/VENT PIPING TO ABOVE CEILING.
  - REMOVE FLOOR DRAIN AND CAP WASTE PIPING AS REQUIRED.
  - REMOVE ONE (1) FLOOR SET JANITORS SINK INCLUDING FAUCET, AND ALL WATER/VENT PIPING TO ABOVE THE CEILING. CAP WASTE PIPING AS REQUIRED.
  - REMOVE ELECTRIC WATER HEATER AND ALL RELATED WATER PIPING TO ABOVE THE CEILING. ALSO REMOVE GAS PIPING AND SHEET METAL EXHAUST FLUE TO ABOVE CEILING CAP GAS PIPING AS REQUIRED.
  - REMOVE WATER SOFTENER AND RELATED WATER PIPING TO ABOVE THE CEILING. (WATER SOFTENER TO BE RELOCATED IN NEW JANITORS CLOSET)
  - REMOVE ALL DRAINING/VENT AND WATER PIPING WITHIN THE PIPE CHASE. REMOVE ALL VERTICAL WATER AND VENT PIPING TO ABOVE THE CEILING, AND CAP PIPING, ADJACENT TO ACTIVE PIPING.
  - REMOVE WALL HUNG ELECTRIC WATER COOLER INCLUDING DRAINS, VENTS AND WATER PIPING. REMOVE VENT AND WATER PIPING TO ABOVE CEILING.
  - REMOVE FLOOR CLEAN OUT AND INSTALL NEW CLEANOUT W/OFFSET AND ACCESS FROM MENS TOILET ROOM.
  - REMOVE 2" COLD WATER DROP INTO CHSE INCLUDING, ALL WATER PIPING WITHIN CHASE.

**PLUMBING ABBREVIATIONS**

SYMBOL	DESCRIPTION
CV	CIRCUIT VENT
CO	CLEANOUT
CP	CIRCULATION PUMP
CS	COLD SOFT WATER
CW	COLD WATER
DFU	DRAINAGE FIXTURE UNIT
E	EXISTING
EC	ELECTRICAL CONTRACTOR
ETR	EXISTING TO REMAIN
FCO	FLOOR CLEAN OUT
FD	FLOOR DRAIN
GC	GENERAL CONTRACTOR
HC	HEATING CONTRACTOR
HW	HOT WATER
HWR	HOT WATER RECIRCULATION
IE	INVERT ELEVATION
L	LAVATORY
MB	MOP BASIN
PC	PLUMBING CONTRACTOR
S	SINK
SAN	SANITARY
V	VENT
VTR	VENT THROUGH ROOF
WCO	WALL CLEAN OUT
WC	WATER CLOSET
WHA	WATER HAMMER ARRESTOR
WHR	WATER HEATER
WSFU	WATER SUPPLY FIXTURE UNIT

SYMBOL	DESCRIPTION
---	SANITARY WASTE
---	SANITARY VENT
---CW---	COLD WATER (CW)
---CS---	COLD SOFT WATER
---HW---	HOT WATER (HW)
---HWR---	HOT WATER RETURN (HWR)
---W---	DOMESTIC WATER SERVICE
⊙	FLOOR DRAIN
⊙	BALL VALVE
⊥	TEE (BRANCH TO SIDE)
⊥	TEE (BRANCH DOWN)
⊥	RISER DOWN
⊥	RISER UP
⊥	CLEANOUT (WALL-WCO OR FLOOR-FCO)
⊥	CLEANOUT
⊥	THERMOMETER
⊥	CHECK VALVE
⊥	UNION
⊥	POINT OF CONNECTION
⊥	WATER HAMMER ARRESTOR
⊥	FIXTURE OR EQUIPMENT STOPS
⊥	PRESSURE GAUGE
⊥	FIXTURE UNITS - DRAIN OR SUPPLY (DFU/WD)

- GENERAL PLUMBING NOTES:**
- VERIFY UTILITY INFORMATION WITH LOCAL UTILITY COMPANIES. VISIT BUILDING SITE AND BECOME THOROUGHLY FAMILIAR WITH ALL EXISTING CONDITIONS AFFECTING THE WORK.
  - VERIFY ALL MEASUREMENTS, PIPE SIZES, PIPE LOCATIONS, ELEVATIONS, ETC, AT ALL SITES.
  - DRAWINGS OF ALL OTHER TRADES SHALL BE REVIEWED. COORDINATE THE INSTALLATION AND SCHEDULING OF THE WORK WITH OTHER TRADES TO PREVENT INTERFERENCE WITH THEIR RESPECTIVE INSTALLATION.
  - REFER TO ARCHITECTURAL DRAWINGS FOR EXACT LOCATION OF ALL PLUMBING FIXTURES, STRUCTURAL DIMENSIONS AND LAYOUT.
  - IT IS THE INTENT OF THESE DRAWINGS THAT A COMPLETE WORKING SYSTEM PROPERLY TESTED WILL BE OPERATIONAL UPON COMPLETION OF INSTALLATION.
  - THE DRAWINGS ARE SCHEMATIC IN NATURE. ALL REQUIRED OFFSETS, FITTINGS AND SUPPORTS SHALL BE INCLUDED IN THE BASE BID TO ACCOMMODATE ACTUAL FIELD CONDITIONS. FINAL LOCATIONS OF ALL WORK SHALL BE COORDINATED IN THE FIELD AND INSTALLED WHERE DIRECTED BY THE OWNERS REPRESENTATIVE.

- PIPING CONNECTION NOTES:**
- CONNECT NEW 2" COLD WATER TO EXISTING BRANCH MAIN PRESENTLY SERVING THE TOILET ROOM WATER CLOSET AND URINALS DOWNSTREAM FROM EXISTING BALL VALVE.
  - CONNECT NEW 3/4" COLD WATER PIPING TO EXISTING PIPING.
  - CONNECT NEW 3/4" HOT WATER PIPING TO EXISTING PIPING.
  - CONNECT NEW 3" VENT TO THE EXISTING 4" VTR.
  - CONNECT THE EXISTING 1-1/2" VENTS SERVING THE EXISTING MENS AND WOMENS TOILET ROOM LAVATORIES TO THE NEW VENT SYSTEMS. VERIFY THE LOCATIONS OF THE VENTS AND MODIFY ROUTING TO SUIT FIELD CONDITIONS.

**SHEET INDEX**

SHEET	DESCRIPTION
P1.0	PARTIAL FIRST FLOOR PLANS, DEMOLITION/GENERAL PLUMBING NOTES, PLUMBING ABBREVIATIONS AND PLUMBING SYMBOLS
P2.0	PLUMBING WASTE/VENT AND WATER PIPING DIAGRAM
FP1.0	FIRE PROTECTING FLOOR PLAN AND NOTES

**PROJECT**  
DANE COUNTY JOB CENTER  
RESTROOM EXPANSION  
1819 ABERG AVENUE  
MADISON, WI  
- RFB # 318045 -

**DRAWING**  
PARTIAL FIRST FLOOR PLANS,  
DEMOLITION/GENERAL PLUMBING  
NOTES, PLUMBING  
ABBREVIATIONS AND PLUMBING  
SYMBOLS

**DATE**  
01/11/19

**P1.0**

Architecture  
Planning

Dorschner Associates, Inc.  
848 E. Washington Ave., Ste 112  
Madison, Wisconsin 53703

**SPD**  
SELECT PLUMBING DESIGN, LLC

4564 EVERGREEN ROAD  
MIDDLETON, WI 53562

(608) 836-9674

Project No. 17-002

ISSUED

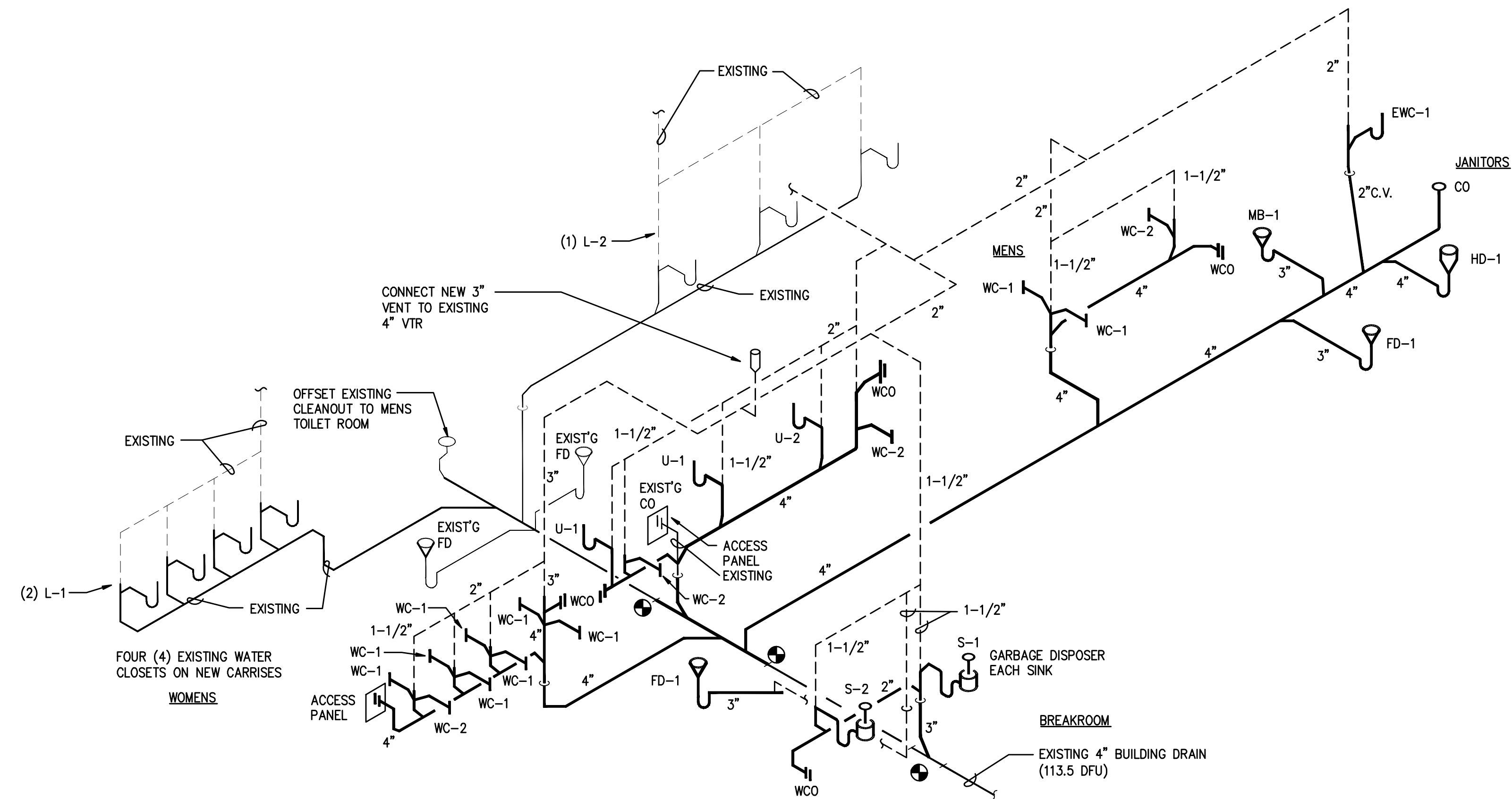

1 SOIL, WASTE AND VENT DIAGRAM  
P2.0 NOT TO SCALE

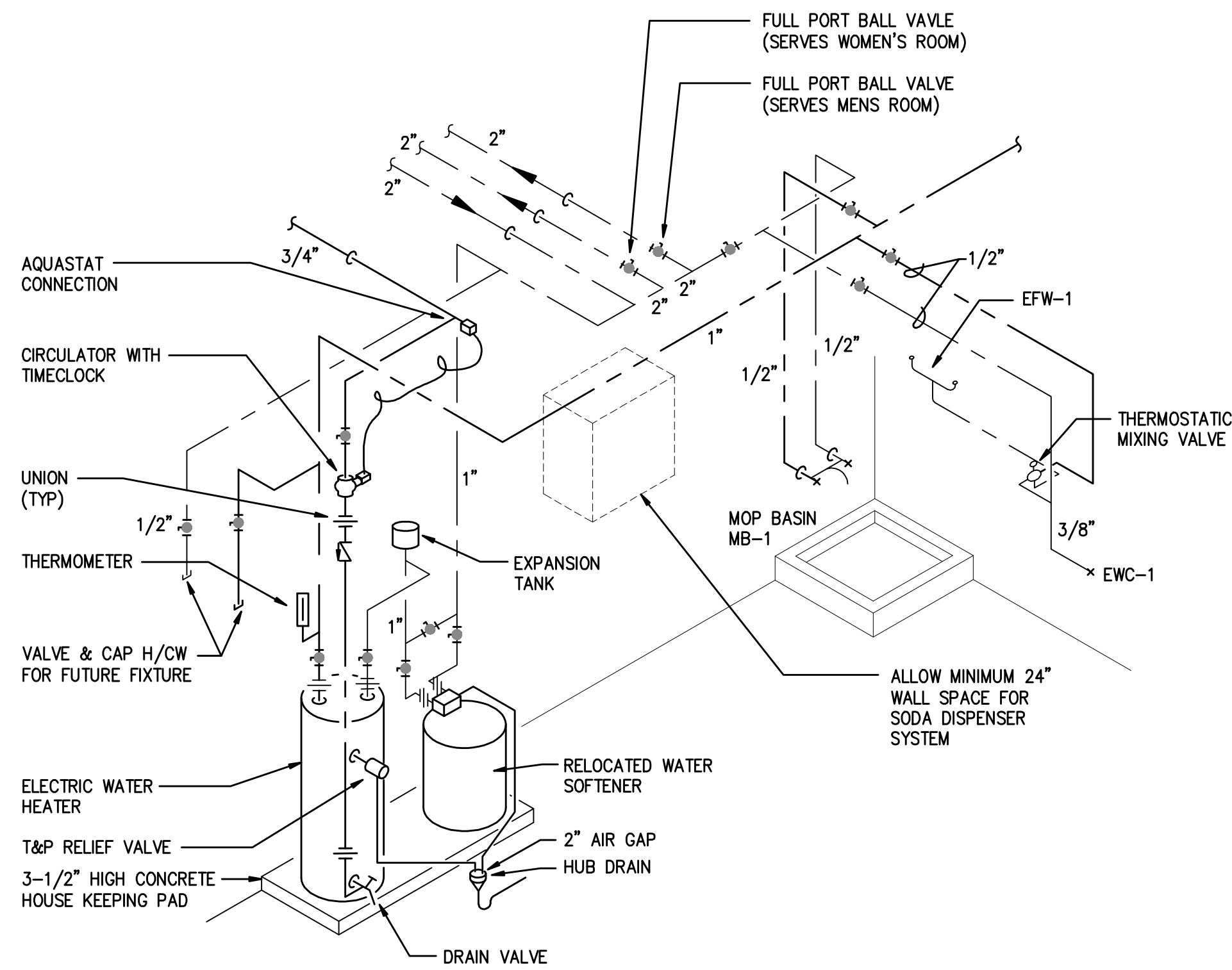

3 JANITORS ROOM PIPING DIAGRAM  
P2.0 NOT TO SCALE

NOTE: ALL WATER PIPING WITHIN JANITORS CLOSET SHALL BE TYPE L COPPER

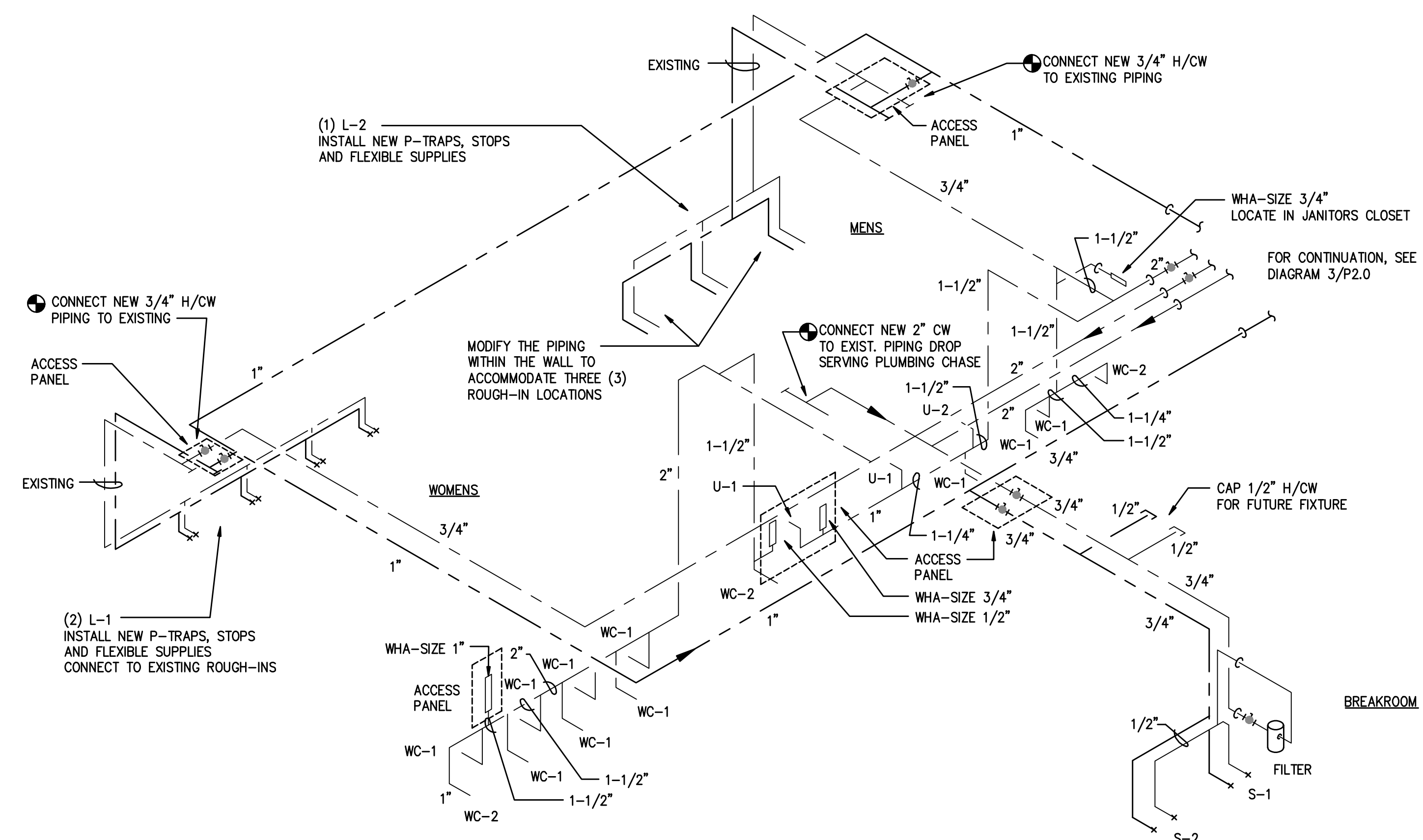

2 WATER PIPING DIAGRAM  
P2.0 NOT TO SCALE

**PROJECT**  
DANE COUNTY JOB CENTER  
RESTROOM EXPANSION  
1819 ABERG AVENUE  
MADISON, WI  
- RFB # 318045 -

**DRAWING**  
PLUMBING WASTE VENT  
AND WATER PIPING DIAGRAM

**DATE**

01/11/19

P2.0

Architecture  
Planning

Dorschner Associates, Inc.  
848 E. Washington Ave., Ste 112  
Madison, Wisconsin 53703

**Engineering 370, LLC**  
MECHANICAL CONSULTING

Oregon, WI 53575  
T: 608-225-9273  
F: 608-835-2077  
Email: info@eng370.com

Project No. 18-0909

ISSUED

**PROJECT**  
DANE COUNTY JOB CENTER  
RESTROOM EXPANSION  
1819 ABERG AVENUE  
MADISON, WI  
- RFB # 318045 -

**DRAWING**

PARTIAL FIRST FLOOR  
HVAC DEMOLITION &  
NEW WORK PLANS

**DATE**

01/11/19

**M1.0**

- GENERAL PIPING NOTES**
- ALL NEW AND EXISTING PIPING IS 3/4" WHEN CONNECTING TO MORE THAN ONE RADIANT CEILING PANEL. PIPING TO SINGLE PANELS CAN BE 1/2".
  - THE RADIANT CEILING PANELS ARE TO BE INSTALLED IN WITH THE PANEL FLUSH WITH THE GYPSUM WALL BOARD CEILING.
  - PIPING CONNECTING TO INDIVIDUAL PANELS MAY BE SOFT COPPER TUBING.
- PIPING NEW WORK KEY NOTES**
- CONNECT TO EXISTING PIPING. INSTALL CONTROL VALVE ABOVE LAN IN PANEL CEILING. EXTEND AND CONNECT TO CUH-6. PROVIDE UNIONS AND DRAIN VALVE IN CUH CABINET.
  - EXISTING STAINLESS STEEL FACE PLATE WITH TEMPERATURE SENSOR TO CONTROL CUH. SEE CONTROL SEQUENCE DETAIL.
  - NEW CEILING RECESSED CUH. SUSPEND FROM EXISTING STRUCTURE. COORDINATE ELEVATION WITH ARCHITECTURAL DRAWINGS.
  - EXISTING VAV BOX NO. 33.
  - APPROXIMATE LOCATION OF EXISTING BRANCH PIPING SERVING EXISTING RCP'S CONNECT TO EXISTING PIPING SERVING MEN'S ROOM RCP AND EXTEND TO RCP 'A' AND 'B'.
  - LOCATE SHUTOFF AND CONTROL VALVES SERVING RCP 'A' AND 'B' ACCESSIBLE THROUGH CEILING ACCESS PANEL.
  - APPROXIMATE LOCATION OF EXISTING BRANCH PIPING SERVING EXISTING RCP'S CONNECT TO EXISTING PIPING SERVING WOMEN'S ROOM RCP AND EXTEND TO RCP 'C' AND 'D'.
  - LOCATE SHUTOFF AND CONTROL VALVES SERVING RCP 'C' AND 'D' ACCESSIBLE THROUGH CEILING ACCESS PANEL.
  - APPROXIMATE LOCATION OF EXISTING 3/4 INCH HWS AND HWR PIPING. MAKE NEW 3/4 INCH CONNECTION TO SERVE RCP 'F' AND 'G'.
  - LOCATE SHUTOFF AND CONTROL VALVES SERVING RCP 'F' AND 'G' ACCESSIBLE THROUGH CEILING ACCESS PANEL.
  - APPROXIMATE LOCATION OF EXISTING 3/4 INCH HWS AND HWR PIPING. MAKE NEW 1/2 INCH CONNECTION TO SERVE RCP 'E'.
  - LOCATE SHUTOFF AND CONTROL VALVES SERVING RCP 'E' ACCESSIBLE THROUGH CEILING ACCESS PANEL.
  - REINSTALL FOUR RCP'S IN NEW CEILING. COORDINATE THE LOCATIONS OF THE PANELS WITH THE STRUCTURAL CEILING SYSTEM.
  - INSTALL THREE NEW RCP'S IN NEW CEILING. COORDINATE THE LOCATIONS OF THE PANELS WITH THE STRUCTURAL CEILING SYSTEM.
  - REINSTALL EXISTING STAINLESS STEEL FACE PLATE WITH TEMPERATURE SENSOR TO CONTROL ASSOCIATED RCP'S. SEE CONTROL SEQUENCE DETAIL.
  - INSTALL NEW STAINLESS STEEL FACE PLATE WITH TEMPERATURE SENSOR TO CONTROL ASSOCIATED RCP'S. SEE CONTROL SEQUENCE DETAIL.
  - REINSTALL CONTROL SERVING VAV #33.

- DEMOLITION KEY NOTES**
- DISCONNECT PIPING TO HOT WATER RADIANT CEILING PANEL AND TEMPORARILY CAP FOR RECONNECTION TO RELOCATED PANEL IN NEW LOCATION. CONTROL VALVE TO REMAIN IN EXISTING LOCATION.
  - HOT WATER RADIANT CEILING PANEL TO BE REMOVED AND RETAINED FOR REINSTALLATION.
  - CONVECTOR TO BE REMOVED.
  - REMOVE HOT WATER PIPING TO ABOVE LUNCHROOM CEILING TO POINT INDICATED. INSTALL NEW VALVES AT END OF PIPING REMAINING.
  - REMOVE RADIANT CEILING PANEL CONTROL SENSOR AT BLANK WALL PLATE, RETAIN FOR REINSTALLATION.
  - EXISTING CONVECTOR CONTROL SENSOR AT BLANK WALL PLATE TO REMAIN FOR CONTROL OF NEW CABINET UNIT HEATER.
  - VAV BOX NO. 33 REMAIN IN EXISTING LOCATION.
  - EXISTING CONTROLLERS FOR RADIANT CEILING PANELS AND CONVECTOR.
  - REMOVE RETURN GRILLE AND DUCT BACK TO MAIN DUCT AND CAP BRANCH.
  - REMOVE TWO TRANSFER GRILLES AND CONNECTING DUCT. RETAIN GRILLES FOR POTENTIAL REINSTALLATION.
  - RETURN GRILLE TO REMAIN.
  - VAV BOX TO REMAIN IN EXISTING LOCATION.
  - REMOVE ALL SUPPLY AIR DUCTWORK AND CEILING DIFFUSERS DOWN STREAM OF VAV BOX.
  - REMOVE THREE EXHAUST GRILLES AND DUCTWORK BACK TO LOCATION INDICATED. NEW CONNECTIONS TO BE MADE TO REMAINING DUCT.
  - REMOVE EXHAUST GRILLE. PATCH OPENING IN MAIN DUCT AIR TIGHT.
  - TRANSFER GRILLES AND EXHAUST GRILLES IN TOILET ROOMS AND CORRIDOR TO REMAIN.
  - RETURN GRILLE TO REMAIN.
  - REMOVE CEILING EXHAUST GRILLE AND RETAIN FOR REINSTALLATION. DUCT TO BE RECONNECTED TO GRILLE IN NEW LOCATION.
  - CONVECTOR TO REMAIN. SERVED BY PIPING THAT SERVES THE RADIANT CEILING PANELS IN RESTROOMS. THE PIPING SHALL REMAIN. REFER TO NOTE 1 ABOVE.
  - APPROXIMATE LOCATION OF SUPPLY AND RETURN PIPING CONNECTIONS TO BUILDING MAINS TO RADIANT CEILING PANELS (RCP). FIELD VERIFY.
  - APPROXIMATE LOCATION OF PIPING TO RCP'S IN MEN'S RESTROOM. FIELD VERIFY. REFER TO NOTE 1 ABOVE.
  - APPROXIMATE LOCATION OF PIPING TO RCP'S IN WOMEN'S RESTROOM. FIELD VERIFY. REFER TO NOTE 1 ABOVE.

- DUCTWORK NEW WORK KEY NOTES**
- MAKE CONNECTION TO EXISTING VAV OUTLET, TRANSITION TO ROUND.
  - REINSTALL EXISTING CEILING DIFFUSER IN LAY-IN PANEL CEILING. COORDINATE FINAL LOCATION WITH CEILING GRID AND LIGHTING FIXTURES.
  - VERIFY ELEVATION OF EG-1 WITH ARCHITECTURAL ELEVATIONS. PROVIDE FULL SIZE PLENUM BOOT AT GRILLE AND REDUCE TO 24/8 DUCT AND TRANSITION TO SIZE INDICATED ON PLAN.
  - 10 X 10 DUCT UP TO PRV-4.
  - REINSTALL TRANSFER GRILLE IN WALL. RUN DUCT FROM GRILLE TO EXISTING GRILLE.
  - CONNECT NEW TRANSFER DUCT TO EXISTING TRANSFER GRILLE IN CORRIDOR. COORDINATE DUCT ELEVATION WITH EXISTING CABLE TRAY AND CONDUIT.
  - EXISTING RETURN GRILLE TO REMAIN.
  - NEW TRANSFER GRILLE EACH SIDE OF WALL. TOP OF GRILLE 3" BELOW CORRIDOR CEILING.
  - PROVIDE SHEET METAL SLEEVE THROUGH WALL.
  - EXISTING RCP AND CONV. CONTROL MODULES. INSTALL NEW RCP AND CUH CONTROL MODULES AT THIS LOCATION. REFER TO SPECIFICATIONS.
  - EXISTING PRV-2
  - EXISTING PRV-3
  - NEW PRV-4. COORDINATE WITH GENERAL CONTRACTOR (GC) ON INSTALLATION OF NEW ROOF CURB. CURB BY HVAC, ROOF OPENING AND ROOFING FOR CURB INSTALLATION BY GC.
  - REINSTALL REMOVED EXHAUST GRILLE. COORDINATE FINAL LOCATION WITH CEILING STRUCTURAL FRAMING.
  - NEW EXHAUST GRILLE. COORDINATE FINAL LOCATION WITH CEILING STRUCTURAL FRAMING.

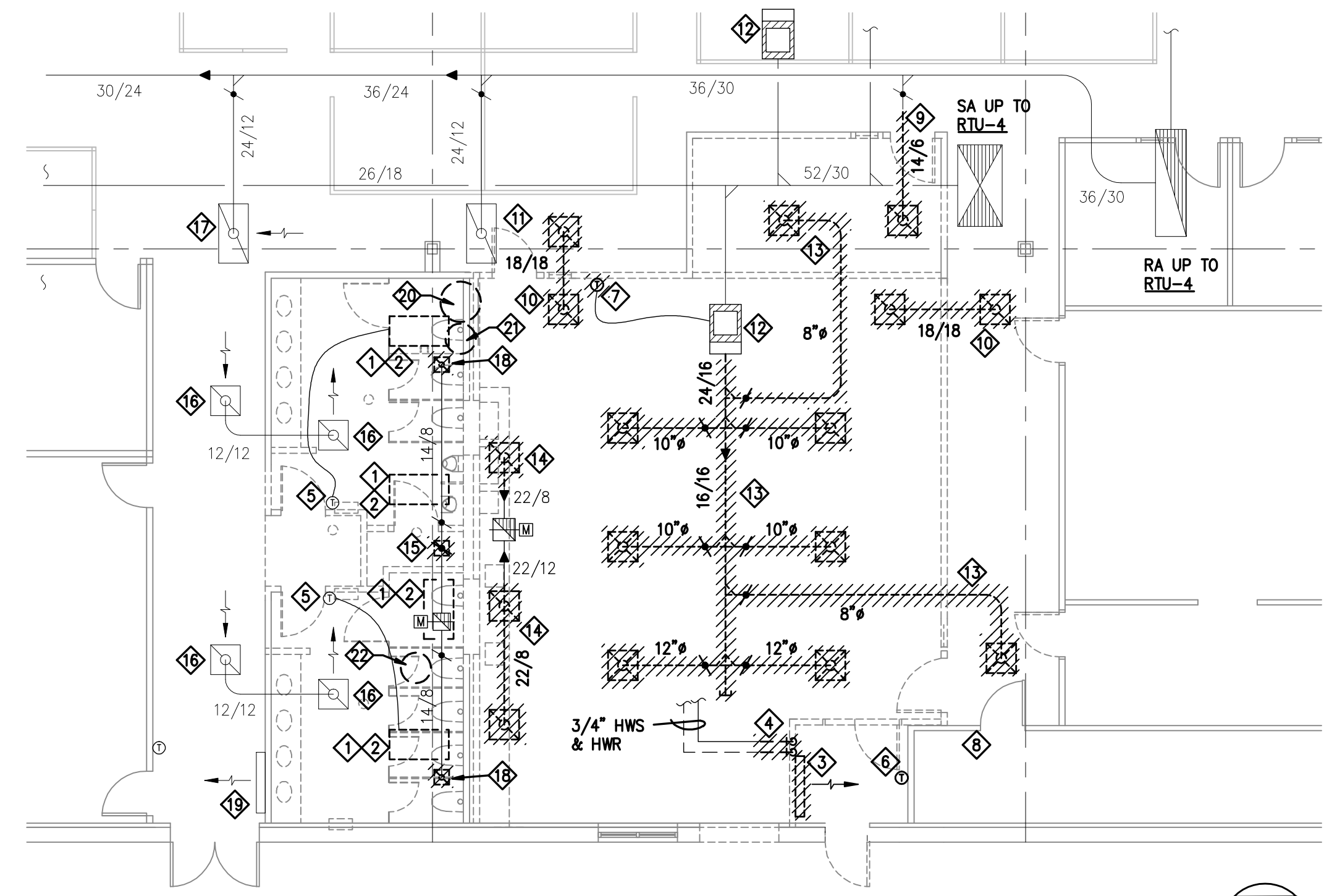

**A** FIRST FLOOR PLAN - HVAC DEMOLITION  
SCALE: 1/8" = 1'-0"

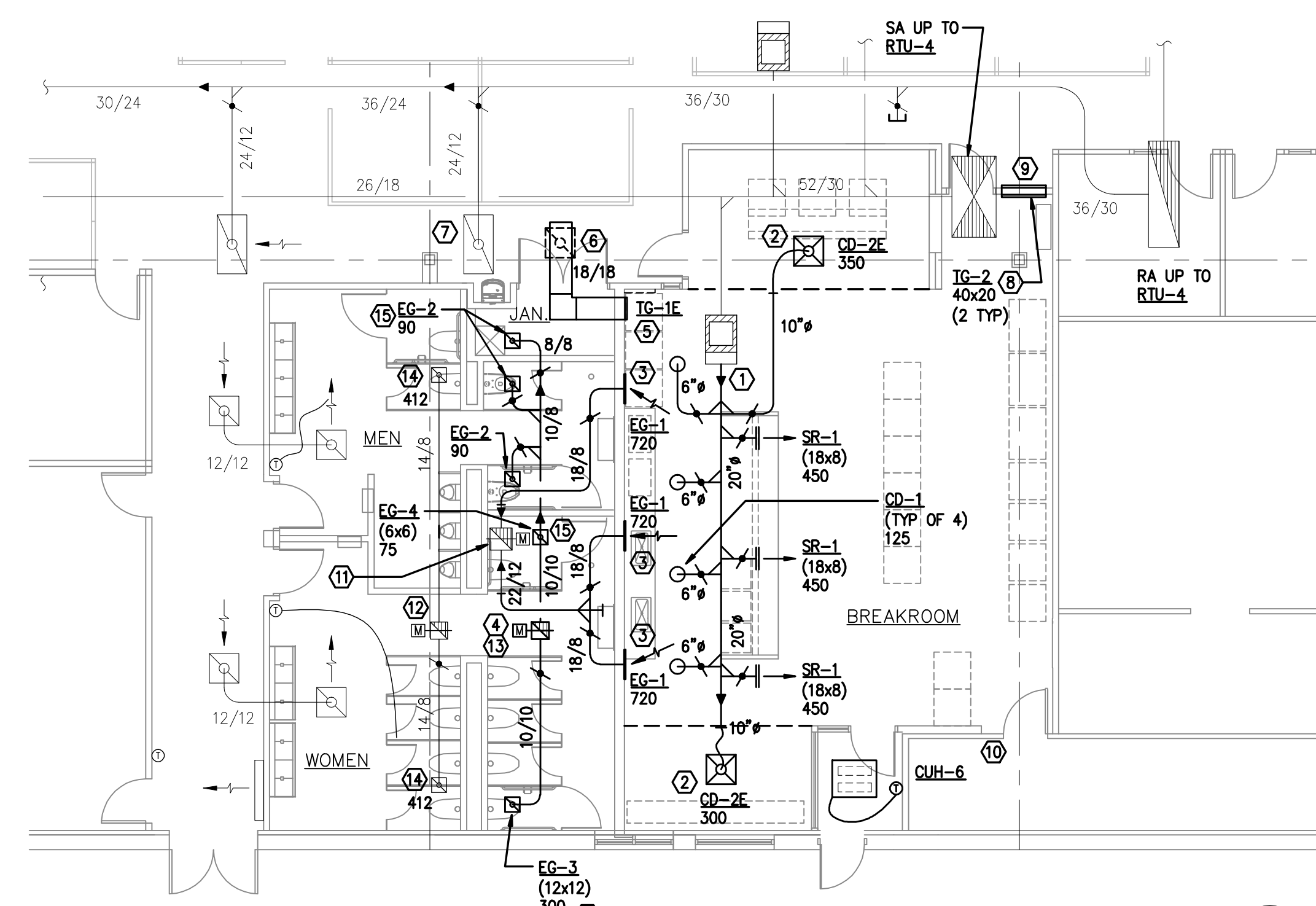

**B** FIRST FLOOR PLAN - HVAC DUCTWORK - NEW WORK  
SCALE: 1/8" = 1'-0"

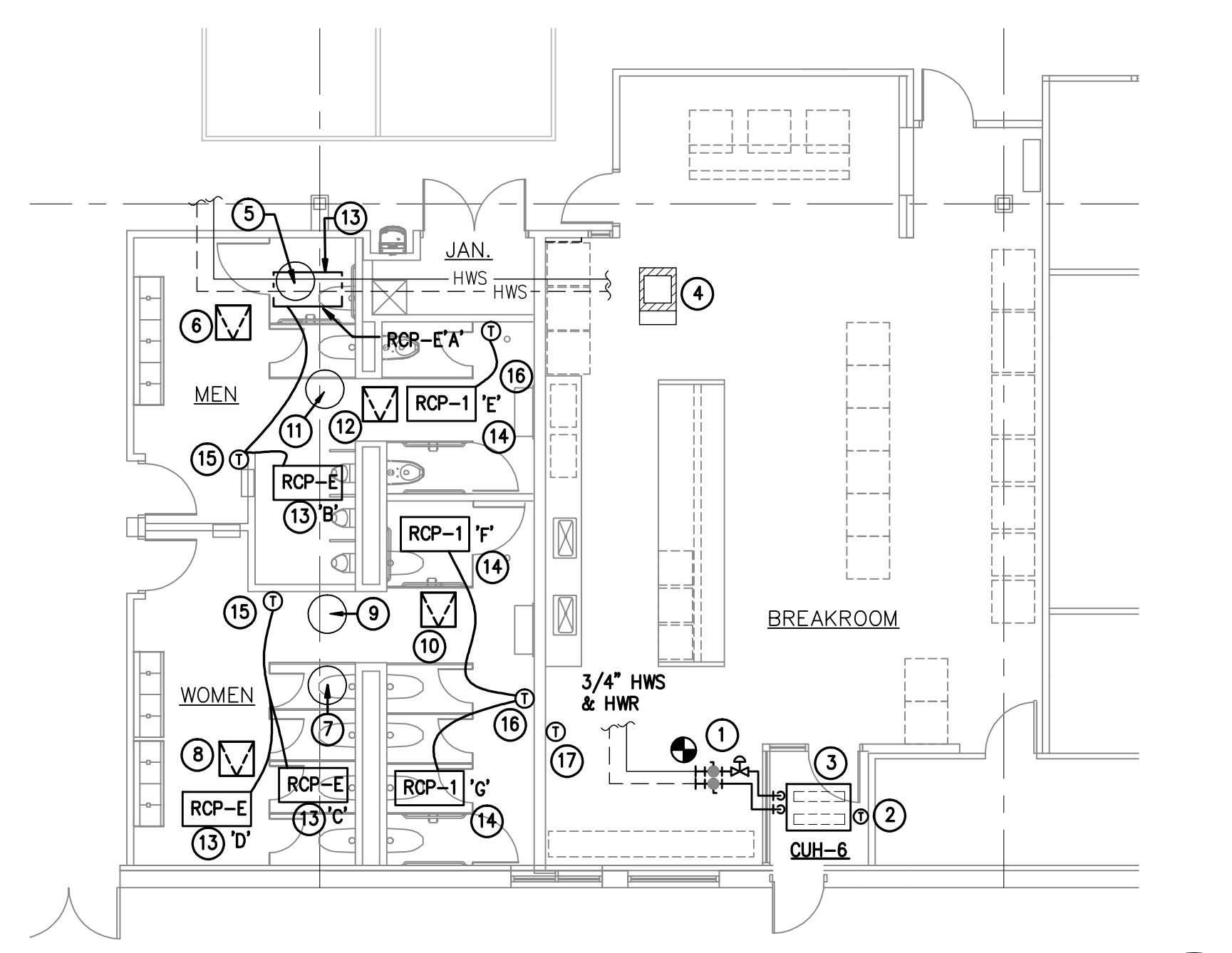

**C** FIRST FLOOR PLAN - HVAC PIPING - NEW WORK  
SCALE: 1/8" = 1'-0"

Architecture  
Planning

Dorschner Associates, Inc.  
848 E. Washington Ave., Ste 112  
Madison, Wisconsin 53703

**Engineering 370, LLC**  
MECHANICAL CONSULTING

Oregon, WI 53575  
T: 608-225-9273  
F: 608-835-2077  
Email: info@eng370.com

Project No. 18-0909

ISSUED

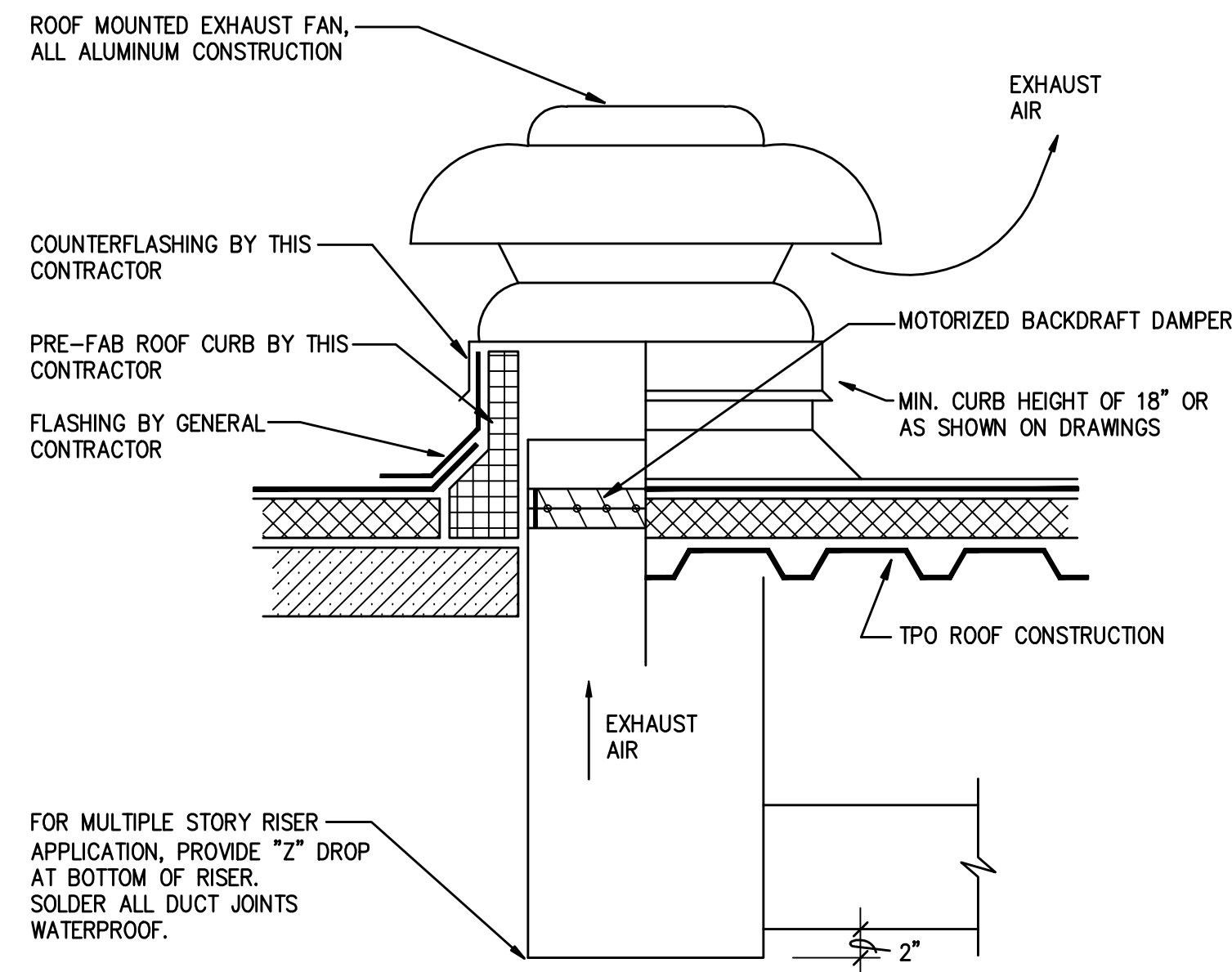

**A** ROOF EXHAUST FAN (PRV) DETAIL  
M2.0 NO SCALE

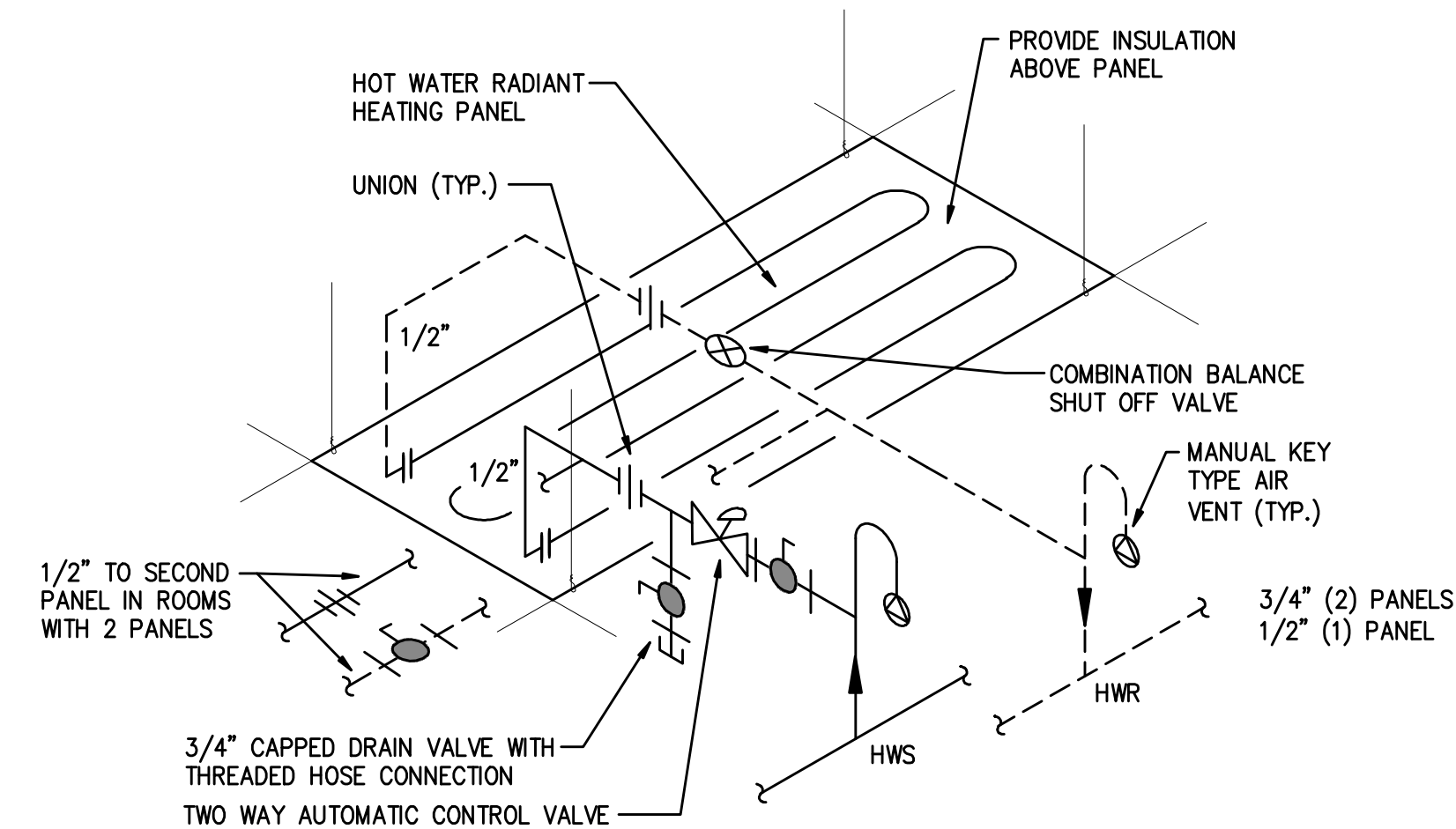

**B** HOT WATER RADIANT CEILING PANEL DETAIL  
M2.0 NOT TO SCALE

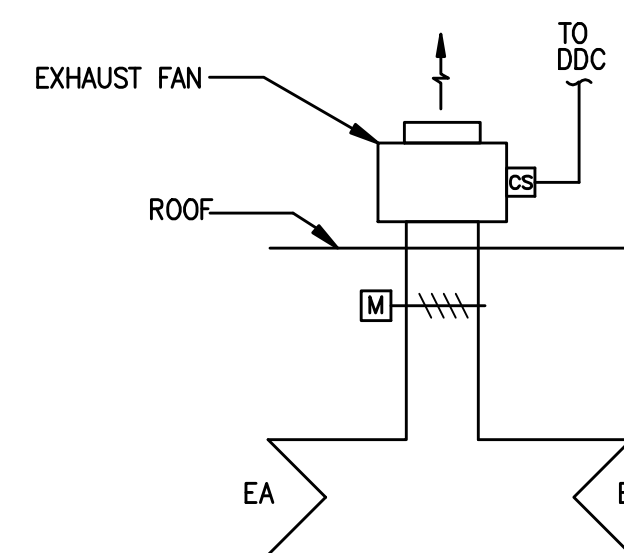

EXHAUST FAN CONTROL PRV-4

SEQUENCE OF OPERATION

PRV-4, SERVING THE EXPANDED RESTROOMS SHALL BE INTERLOCKED WITH THE EXISTING RTU SERVING THE AREA. THE UNIT CONTROL SHALL BE THE SAME AS THE EXISTING PRV-2 AND PRV-3 SERVING THE EXISTING RESTROOMS AND BREAK ROOM. WHEN THE RTU IS IN THE OCCUPIED MODE THE LINE VOLTAGE BACKDRAFT DAMPER SHALL OPEN AND ON PROOF OF DAMPER OPEN THE FAN SHALL BE ENERGIZED. WHEN THE RTU IS IN THE UNOCCUPIED MODE THE FAN SHALL BE OFF AND BACKDRAFT DAMPER CLOSED. FAN SHALL BE DE-ENERGIZED AND THE DAMPER CLOSED ON A SIGNAL FROM THE FIRE ALARM SYSTEM.

**C** EXHAUST FAN CONTROL (EF-2)  
M2.0 NO SCALE

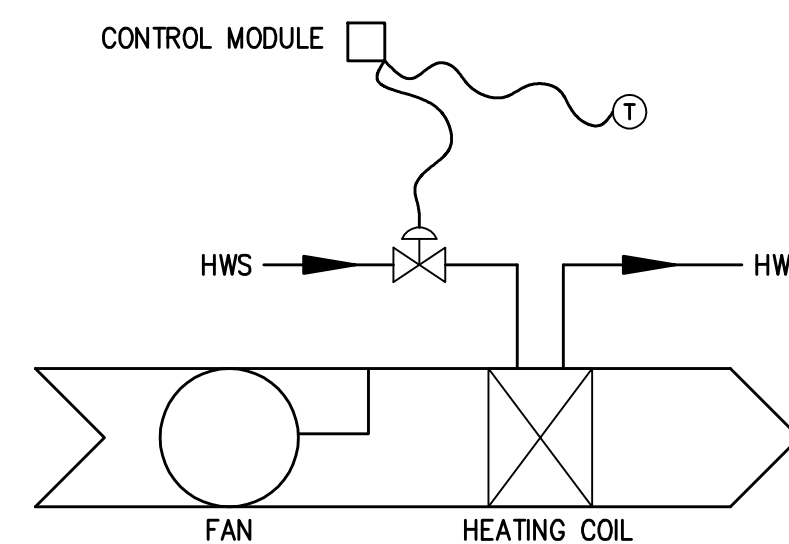

HOT WATER CABINET UNIT HEATER CONTROL

SEQUENCE OF OPERATION

AN EXISTING SINGLE TEMPERATURE SENSOR (CONTROLLING AN EXISTING CONVECTOR), LOCATED AS INDICATED ON THE DRAWINGS SHALL MAINTAIN THE SPACE SET POINT BY ACTUATING A TWO WAY, TWO POSITION ELECTRIC CONTROL VALVE. A SINGLE TEMPERATURE ELECTRIC STRAP ON THERMOSTAT LOCATED ON THE HWR PIPE SHALL CYCLE THE UNIT FAN WHENEVER THE HWR TEMPERATURE IS ABOVE 95 DEG. F.

**D** HOT WATER CABINET UNIT HEATER CONTROL  
M2.0 NO SCALE

GRILLE, REGISTER, DIFFUSER SCHEDULE												
MARK	MANUFACTURER	MODEL NO.	DESCRIPTION	MATERIAL	MOUNTING	AIR PATTERN	SIZE	CFM	DAMPER	APD MAX. W.C.	ACCESSORIES	REMARKS
CD-1	CARNES	SSAA-1	ROUND	STEEL	EXPOSED DUCT	360 DEG.	6 INCH INLET	125	NO	0.05		1, 2, 3
CD-2E	EXISTING	EXISTING	LAY-IN	ALUM	T-BAR GRID		10 ROUND NECK	SEE PLAN	NO			3, 6
SR-1	CARNES	RSDBH	DOUBLE DEFLECTION	STEEL	DUCT	22-1/2 DEGREE	18 X 8	450	YES	0.05		4, 5
EG-1	CARNES	RAAMH	3/4" BLADE SPACING	ALUM	FLANGE WALL	45 DEGREE	24 X 12	750	YES	0.05		7
EG-2	CARNES	RAAMH	3/4" BLADE SPACING	ALUM	FLANGE CEILING	45 DEGREE	8 X 8	90	YES	0.05		
EG-3	CARNES	RAAMH	3/4" BLADE SPACING	ALUM	FLANGE CEILING	45 DEGREE	12 X 12	300	YES	0.05		
EG-4	CARNES	RAAMH	3/4" BLADE SPACING	ALUM	FLANGE CEILING	45 DEGREE	6 X 6	75	YES	0.05		
TG-1E	EXISTING	EXISTING			FLANGE WALL		20 X 20		NO			7, 8
TG-2	CARNES	RSABH	3/4" BLADE SPACING	STEEL	FLANGE WALL		40 X 20		NO			7
TG-3E	EXISTING	EXISTING			FLANGE CEILING				NO			8

REMARKS

- 1 ROUND NECK, SIZE AS INDICATED BY SIZE OF SUPPLY DUCT
- 2 FORM 1, 14.25 OVERALL DIAMETER
- 3 BALANCING DAMPER IN SUPPLY DUCT
- 4 PROVIDE 6 INCH DEEP BOOT AT SIDE OF ROUND DUCT. BOOT OVERALL SIZE SHALL BE SAME AS OVERALL DIMENSION OF REGISTER
- 5 ADJUST BLADES TO PROVIDE THROW ANGLE INDICATED IN AIR PATTERN
- 6 REINSTALL REMOVED DIFFUSER
- 7 MOUNT IN WALL WITH BLADES POSITIONED TO LIMIT SITE THROUGH GRILLE
- 8 EXISTING GRILLE TO BE REINSTALLED. GRILLE IS 20 X 20 WITH EXTENSION FOR ORIGINAL INSTALLATION IN 24 X 24 LAY-IN CEILING GRID

FAN SCHEDULE															
MARK	LOCATION	MANUFACTURER	MODEL NO.	FAN PERFORMANCE		FAN DATA				MOTOR DATA			REMARKS		
				AIR FLOW (CFM)	EXT STATIC PRESS	FAN TYPE	DRIVE TYPE	RPM	TIP SPEED	OUTLET VELOCITY	BHP	HP		VOLTS / PHASE	
PRV-4	SEE PLAN	CARNES	VEBK 08	645	0.375	PRV	BELT	1525				0.11	1/4	120/1	1

REMARKS 1. INCLUDE LINE VOLTAGE MOTOR OPERATED BACK DRAFT DAMPER.

HOT WATER CABINET HEATERS

TAG	MFGR.	MODEL	TYPE	AIRFLOW (CFM)	MBH	GPM	EWT (°F)	LWT (°F)	WPD FT HEAD	HP/WATT	VOLT-PHASE	REMARKS
CUH-6	TRANE	FFEB 020	HORIZ RECESS	200 (NOM)	16	1.1	180	150	5.85	0.22 HP	120/1	1

REMARKS 1 2 ROW HOT WATER COIL

HOT WATER RADIANT CEILING PANEL

MARK	MANUFACTURER	MODEL	PANEL SIZE	NO. OF PASSES	AWT DEG F	CAPACITY (MBH)	GPM	REMARKS
RCP-1	STERLING	MODULAR	2X4'	6	170	1.4	1	1, 2, 3

REMARKS

- 1 INSTALL PANELS IN ACCORDANCE WITH MANUFACTURERS INSTRUCTIONS.
- 2 COORDINATE THE RADIANT CEILING PANEL WITH THE CEILING TYPE IN FIELD PRIOR TO ORDERING
- 3 REFER TO PIPING DETAIL FOR PIPING ONE AND TWO PANELS PER CONTROL VALVE.

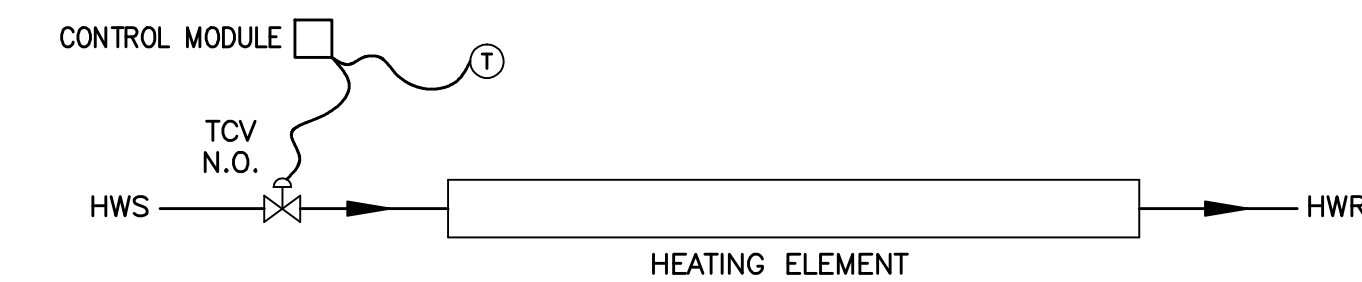

HOT WATER RADIANT CEILING PANEL

SEQUENCE OF OPERATION

AN EXISTING SINGLE TEMPERATURE SENSOR (CONTROLLING EXISTING RCP'S OR NEW RCP'S AS INDICATED ON THE DRAWINGS), LOCATED AS INDICATED ON THE DRAWINGS SHALL MAINTAIN THE SPACE SET POINT BY ACTUATING A TWO WAY, TWO POSITION ELECTRIC CONTROL VALVE. EXISTING SENSORS ARE STAINLESS STEEL FLAT PLATE SENSORS TO BE RELOCATED OR SIMILAR UNITS TO CONTROL NEW RCP'S.

**E** HOT WATER RADIANT CEILING PANEL CONTROL  
M2.0 NO SCALE

**PROJECT**  
DANE COUNTY JOB CENTER  
RESTROOM EXPANSION  
1819 ABERG AVENUE  
MADISON, WI  
- RFB # 318045 -

**DRAWING**

HVAC SCHEDULES  
AND DETAILS

**DATE**

01/11/19

**M2.0**



REMOVE EXISTING (42) CIRCUIT 200Y/120V SURFACE MOUNTED PANEL. REPLACE WITH (12) CIRCUIT PANEL. RECONNECT TO EXISTING 100 AMPERE FEEDER. REPLACE EXISTING BREAKERS (FIELD VERIFY):  
2 - 20A, 3P  
1 - 20A, 2P  
28 - 20A, 1P  
ADD (30) MORE 20A, 1P BREAKERS. RECONNECT EXISTING CIRCUITS. REDO CIRCUIT DIRECTORY. LEAVE SPARES IN 'OFF' POSITION.

1 PANEL "F"  
N.T.S.

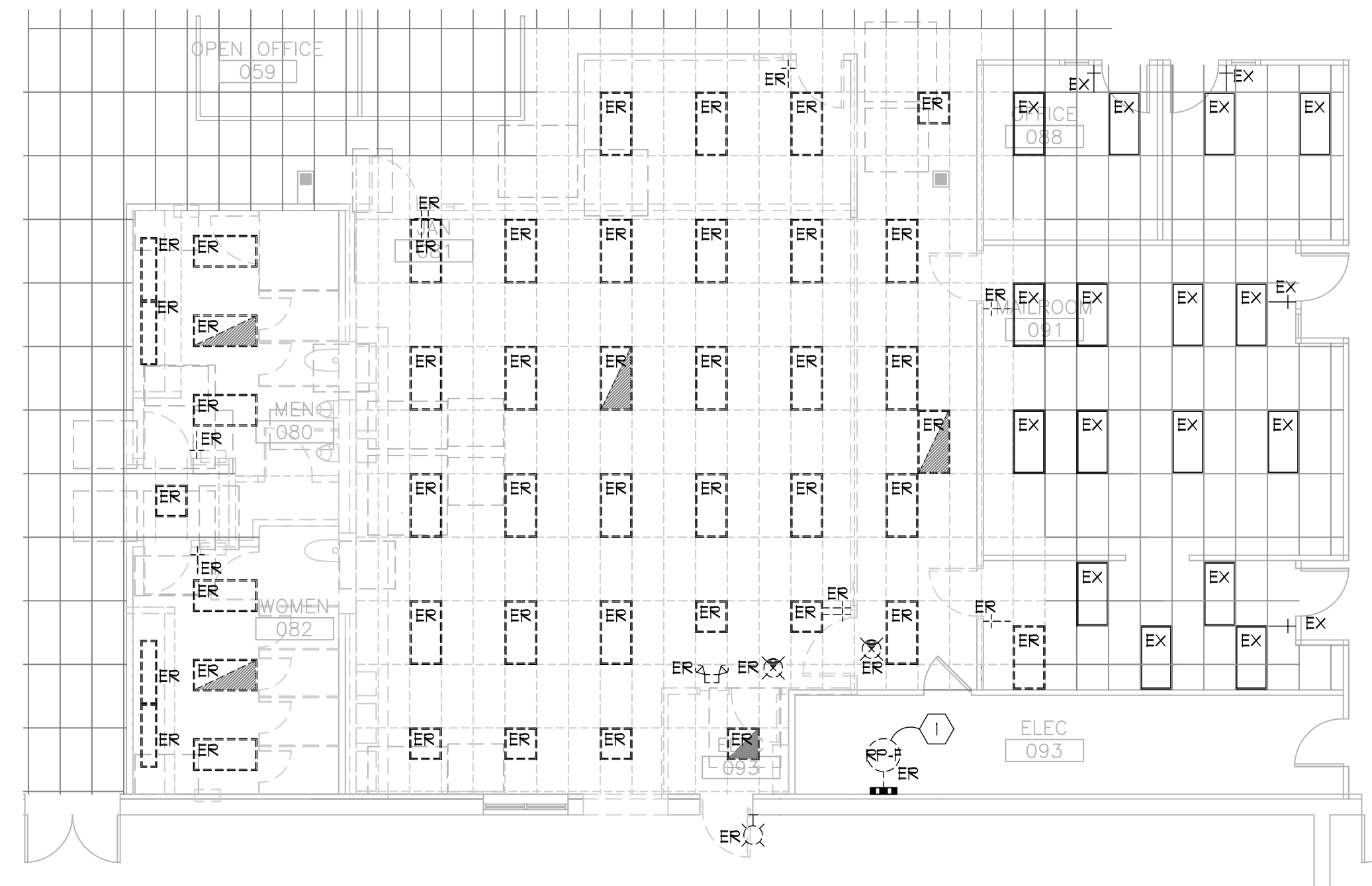

1 PARTIAL FIRST FLOOR PLAN - DEMOLITION LIGHTING  
1/8"=1'-0"

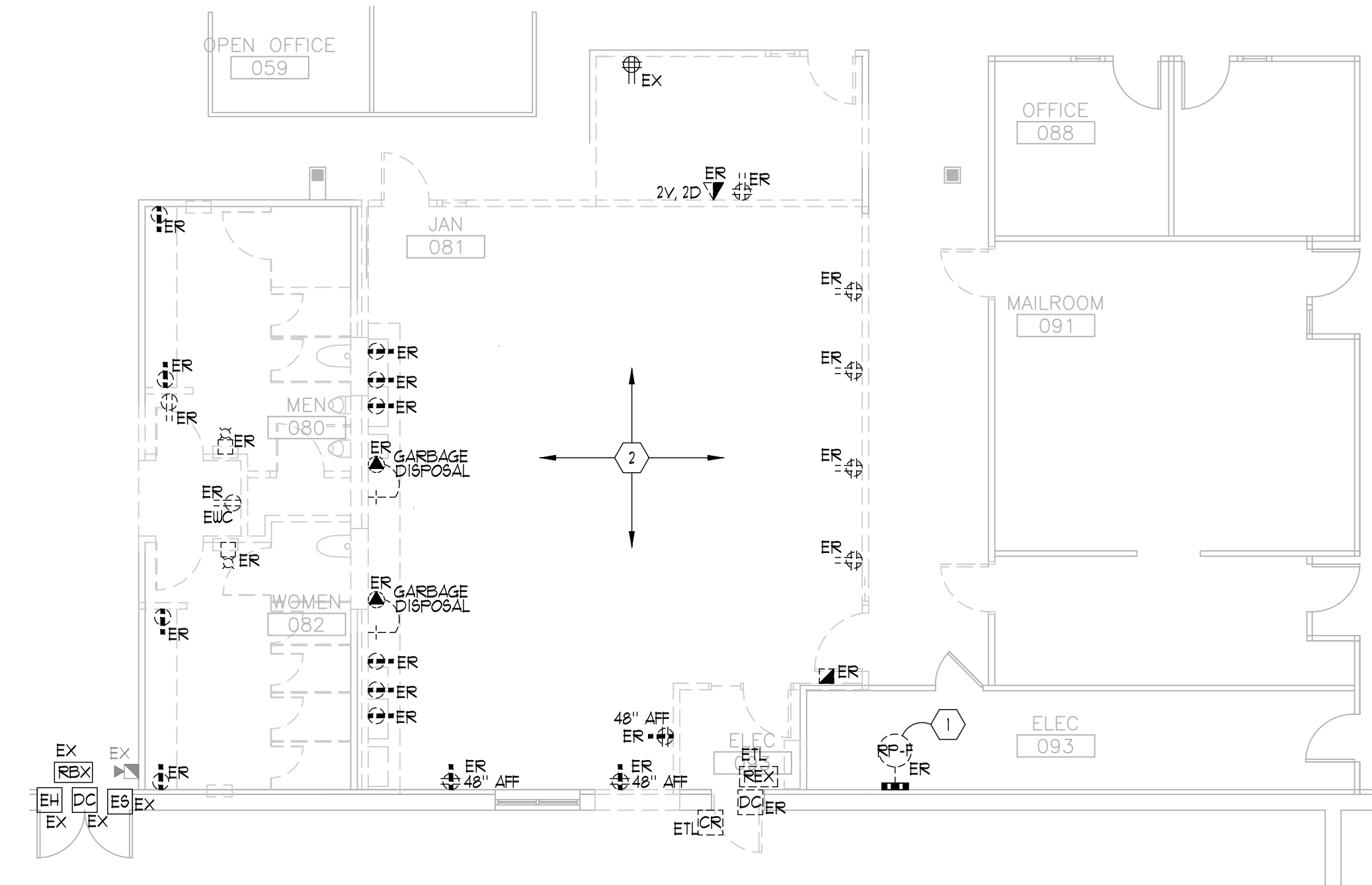

2 PARTIAL FIRST FLOOR PLAN - DEMOLITION POWER/SYSTEMS  
1/8"=1'-0"

PANEL "F"												
225 AMPS MAIN LUG		200Y/120 VOLT, THREE PHASE, FOUR WIRE										LOCATION: SEE PLAN
MOUNTING TYPE: SURFACE		SHORT CIRCUIT INTERRUPTING RATING: 10 K.A.I.C.										
CIRCUIT BKR.	LOAD DESCRIPTION	LOAD TYPE	CIRCUIT #	PHASE LOADS			CIRCUIT #	LOAD TYPE	LOAD DESCRIPTION	CIRCUIT BKR.	AMPS	POLES
				WATTS	A	B						
20	1	S.O. UCR-1	R	800	1	1800	2	1000	R	S.O. REF-1	20	1
20	1	S.O. UCR-2	R	800	3	1800	4	1000	R	S.O. REF-2	20	1
20	1	S.O. UCR-3	R	800	5	1800	6	1000	R	S.O. REF-3	20	1
20	1	S.O. FUTURE	R	1500	7	2500	8	1000	R	S.O. REF-4	20	1
20	1	S.O. MICR-1	R	1500	9	2500	10	1000	R	S.O. REF-5	20	1
20	1	S.O. MICR-2	R	1500	11	2500	12	1000	R	S.O. EWC	20	1
20	1	S.O. MICR-3	R	1500	13	3000	14	1500	R	S.O. VEND-1	20	1
20	1	S.O. MICR-4	R	1500	15	3000	16	1500	R	S.O. VEND-2	20	1
20	1	MOTOR "PRV-1"	V	778	17		18	1500	R	S.O. VEND-3	20	1
20	1	RECEPTACLE - 4 GFI	R	800	19	2000	20	1200	R	RECEPTACLE - 5 & S.O. CUH-6	20	1
20	1	S.O. GD-1	R	972	21	1972	22	1000	R	RECEPTACLE - 5	20	1
20	1	S.O. GD-2	R	972	23	1772	24	800	R	RECEPTACLE - 4	20	1
20	3	S.O. WH-1	E	500	25	1800	26	1300	K	S.O. HWD-1	20	1
-	-	X	E	500	27	1800	28	1300	K	S.O. HWD-2	20	1
-	-	X	E	500	29	2000	30	1500	E	S.O. HD-1	20	1
20	1	S.O. HD-3	E	1500	31	3000	32	1500	E	S.O. HD-2	20	1
20	1	S.O. HD-4	E	1500	33	2500	34	1000	R	S.O. REF-6	20	1
				35			36	600	R	RECEPTACLE - (3)	20	1
				37	0		38					
				39	0		40					
				41	0		42					
				43	0		44					
				45	0		46					
				47	0		48					
				49	0		50					
				51	0		52					
				53	0		54					
				55	0		56					
				57	0		58					
				59	0		60					
				61	0		62					
				63	0		64					
				65	0		66					
				67	0		68					
				69	0		70					
				71	0		72					
				14100	13872	10950						
										PANEL TOTAL LOAD =	38.6	KW
											107.2	AMP

NOTES:  
1) REPLACE EXISTING PANEL. SEE SHEET 1.  
2) XXX  
3) XXX

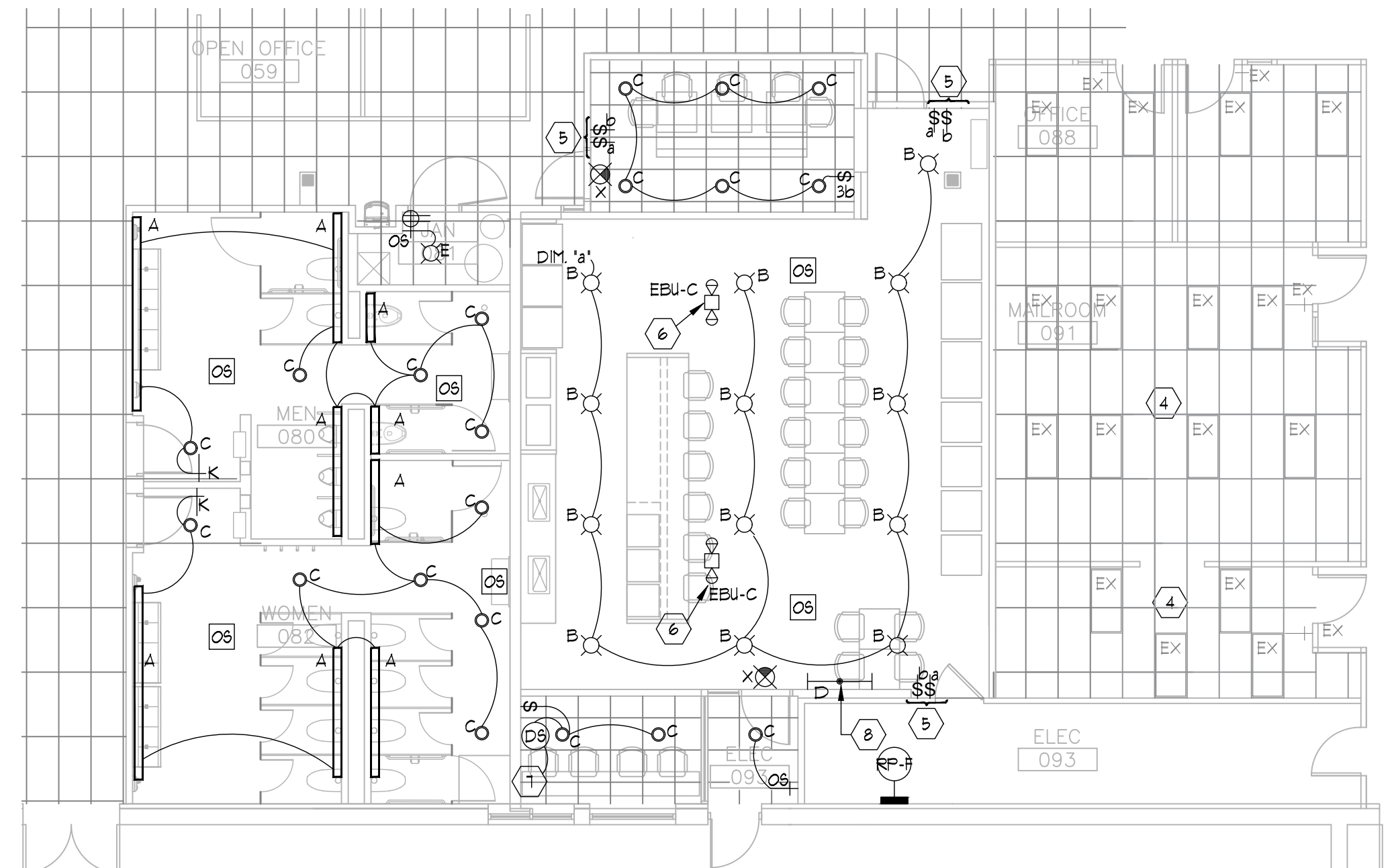

3 PARTIAL FIRST FLOOR PLAN - LIGHTING  
1/8"=1'-0"

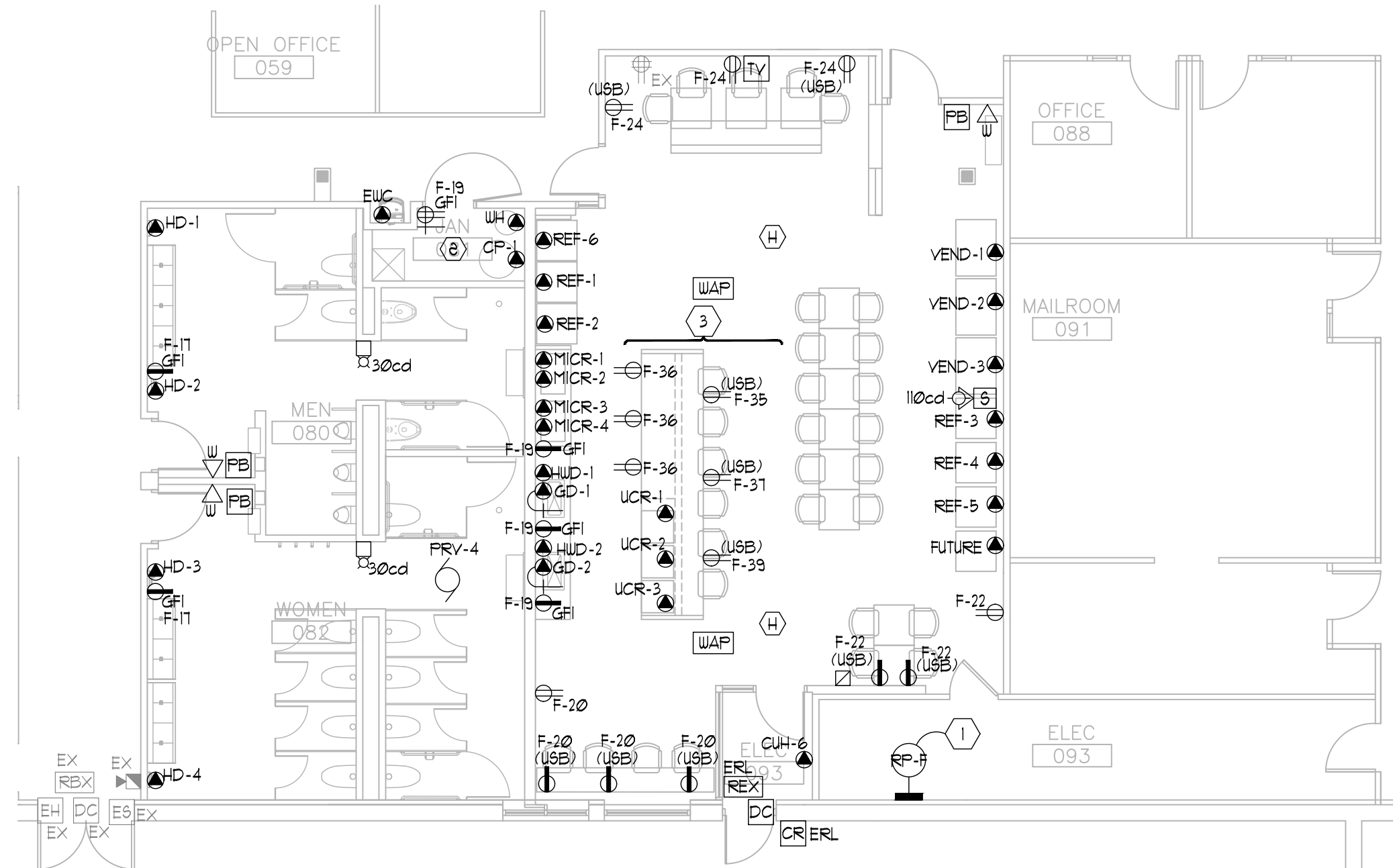

4 PARTIAL FIRST FLOOR PLAN - POWER/SYSTEMS  
1/8"=1'-0"

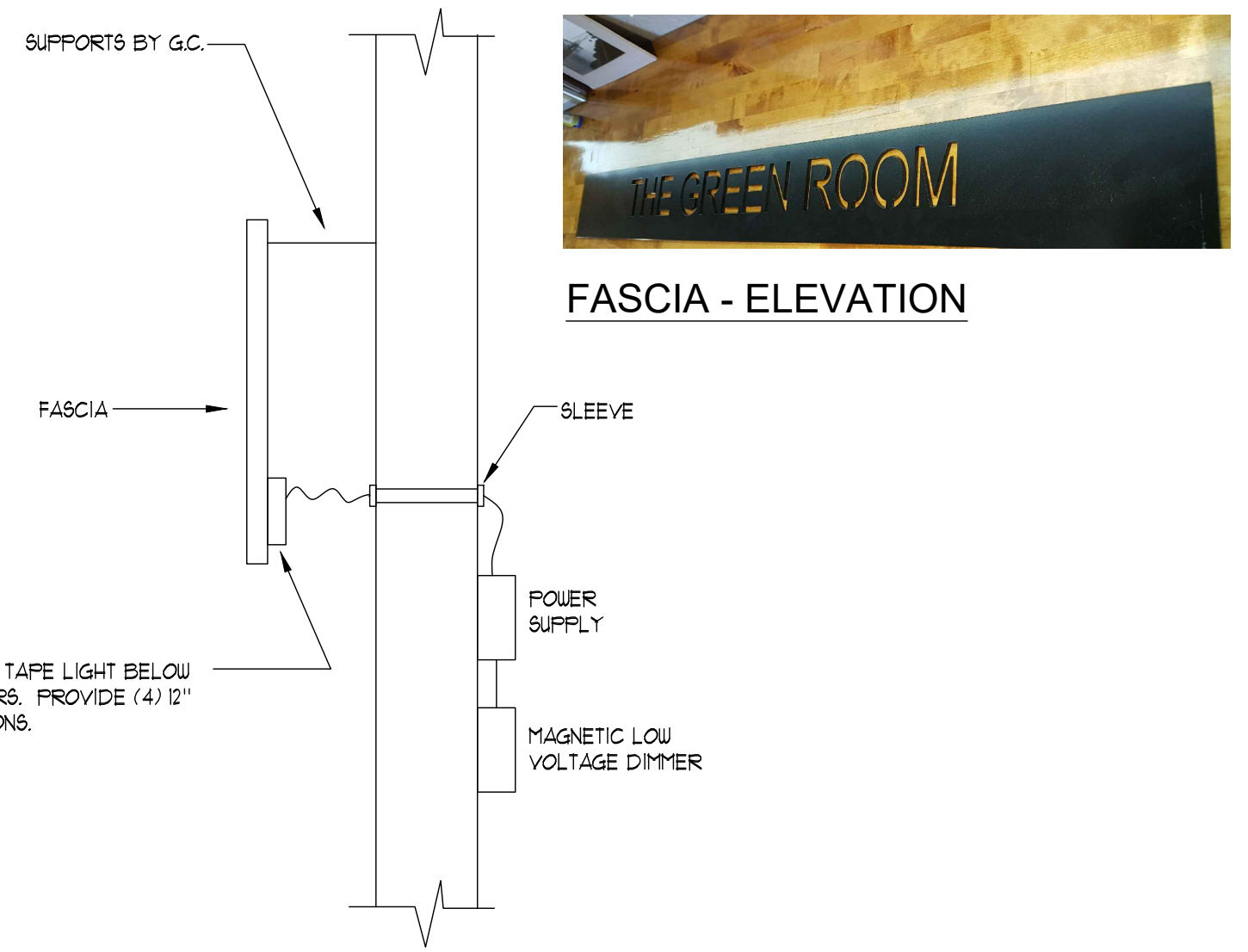

A DETAIL  
NOT TO SCALE

GENERAL NOTES:

1. WIRE LIGHTING TO EXISTING CIRCUITS SERVING AREA.
2. WIRE EXIT LIGHTS AND BATTERY UNITS TO LIGHTING CIRCUITS AHEAD OF SWITCHES.

KEYED NOTES:

1. REPLACE EXISTING PANEL.
2. EXISTING CABLES SHALL BE REINSTALLED AT STRUCTURAL CEILING AND ROUTED IN CONTACT WITH TOP CHORD OF JOIST AND DECK FOR THE ENTIRE RUN. CABLES TO BE CONCEALED AS MUCH AS POSSIBLE IN EXPOSED CEILING AREA.
3. CUT AND PATCH FLOOR FOR NEW WIRING. COORDINATE OUTLET LOCATIONS AND CONDUIT ROUTING WITH MILLWORK CONTRACTOR.
4. REWIRE LIGHTING TO EXISTING SWITCH AT SOUTH DOOR.
5. PROVIDE MULTI-LOCATION DIMMERS:  
DIM 'a' - 0 TO 10 VOLT.  
DIM 'b' - 0 TO 10 VOLT.
6. PENDANT MOUNT FROM RIGID STEMS AND SWIVEL HANGERS 8'-0" AFF.
7. PROVIDE DAYLIGHT SENSOR WITH WITH 0-10V OUTPUT TO DIM 'c' FIXTURES TO SET POINT.
8. MOUNT FIXTURE BEHIND METAL FASCIA - VERIFY HEIGHT WITH ARCHITECT. WIRE TO ROOM LIGHTING CIRCUIT DOWN STREAM OF OCCUPANCY SENSORS BUT BEFORE DIMMING CONTROLS. INSTALL DRIVER IN ELECTRICAL ROOM.

2018-9116.00  
**GRAEF**  
One Honey Creek Corporate Center  
125 South 84th Street, Suite 401  
Milwaukee, WI 53214-1470  
414 / 259 1500  
414 / 259 0037 fax

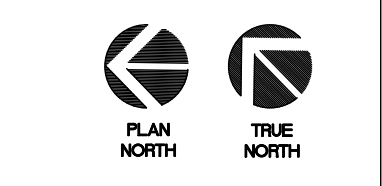

PROJECT  
DANE COUNTY JOB CENTER  
RESTROOM EXPANSION  
1819 ABERG AVENUE  
MADISON, WI

DRAWING  
PARTIAL FIRST FLOOR  
ELECTRICAL DEMOLITION  
AND NEW PLANS  
DATE  
01.11.19

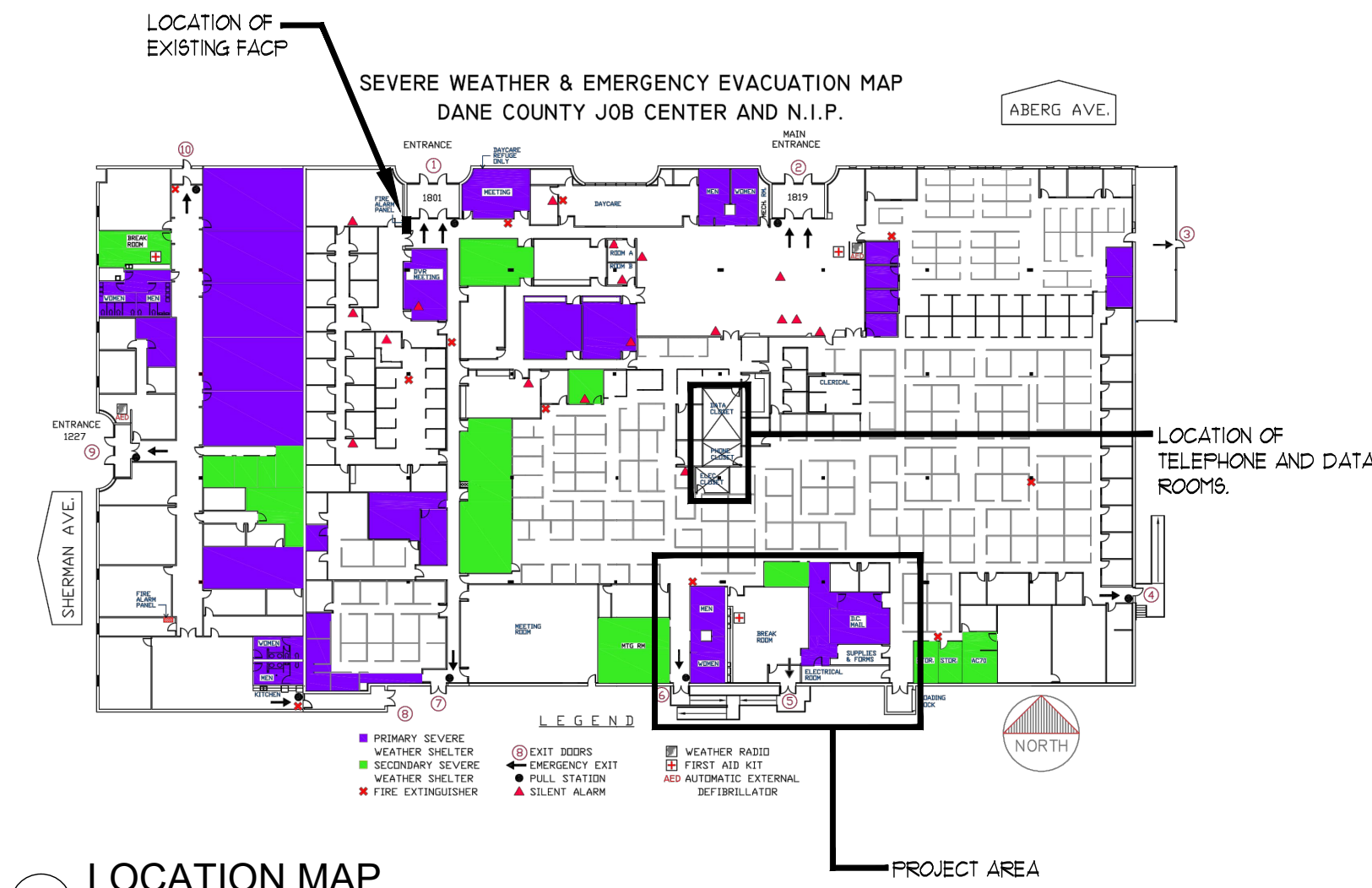
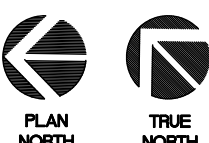

1 LOCATION MAP  
N.T.S.

ELECTRICAL SYMBOLS

- RECESSED, SURFACE OR PENDANT FIXTURE
RECESSED FIXTURE
SURFACE OR PENDANT FIXTURE
WALL MOUNTED FIXTURE
EMERGENCY BATTERY UNIT - CEILING MOUNTED
MOUNTED EXIT SIGN - CEILING MOUNTED
OCCUPANCY SENSOR (AUTO OFF / AUTO FULL ON) - CEILING MOUNTED
OCCUPANCY SENSOR (AUTO OFF / AUTO 50% ON) - CEILING MOUNTED
DAYLIGHT SENSOR
SINGLE POLE TOGGLE SWITCH - MOUNT 48" ABOVE FLOOR TO TOP OF BOX - (3) THREE WAY - (4) FOUR WAY - (K) KEY - (P) PILOT LIGHT - (OS) OCCUPANCY SENSOR (AUTO OFF / AUTO FULL ON) - (VS) VACANCY SENSOR (AUTO OFF / MANUAL ON)
DIMMER SWITCH - MOUNT 48" ABOVE FLOOR TO TOP OF BOX - (3) THREE WAY - (4) FOUR WAY - (OS) OCCUPANCY SENSOR (AUTO OFF / AUTO FULL ON) - (VS) VACANCY SENSOR (AUTO OFF / MANUAL ON)
DUPLEX RECEPTACLE - MOUNT 15" ABOVE FLOOR TO BOTTOM OF BOX OR HEIGHT AS INDICATED - (GFI) GROUND FAULT CIRCUIT INTERRUPTER - (UP) WEATHER PROOF - (USB) USB PORTS
DUPLEX RECEPTACLE - MOUNT HORIZONTAL ABOVE COUNTER - (GFI) GROUND FAULT CIRCUIT INTERRUPTER - (USB) USB PORTS
SPECIAL OUTLET
ELECTRICAL PANEL
TELEPHONE OUTLET - MOUNT 15" ABOVE FLOOR TO BOTTOM OF BOX - (U) WALL PHONE MOUNT 48" TO TOP OF BOX (C) ABOVE COUNTER OR HEIGHT AS INDICATED
WIRELESS ACCESS POINT
DOOR CONTACT
PANIC BUTTON
CARD READER
REQUEST TO EXIT SENSOR
MOTOR

FIRE ALARM SYMBOLS

- FIRE ALARM FULL STATION - MOUNT 48" AFF TO TOP OF BOX
FIRE ALARM STROBE - MOUNT 80" TO BOTTOM OF BOX OR 6" DOWN FROM CEILING TO TOP OF BOX WHICHEVER IS LOWER
SPEAKER/STROBE - MOUNT 80" AFF TO BOTTOM OF BOX OR 6" DOWN FROM CEILING TO TOP OF BOX WHICHEVER IS LOWER (\*) IS CANDELA RATING
HEAT DETECTOR - 135°F FIXED 4 RATE OF RISE (5°F/M) (20°F/M) UNLESS NOTED ON THE PLANS
EXISTING FIRE ALARM FULL STATION WITH EXISTING SPEAKER/STROBE ABOVE
EXISTING FIRE ALARM FULL STATION



2 EXISTING FACP  
N.T.S.

ABBREVIATIONS

- AFF ABOVE FINISHED FLOOR
AFG ABOVE FINISHED GRADE
BOL BUILT-IN OVERLOAD
C CONDUIT
CKT CIRCUIT
CB COMBINATION STARTER
D DEDICATED
DD DOUBLE DUPLEX
EC ELECTRICAL CONTRACTOR
EWC ELECTRIC WATER COOLER
ER EXISTING TO BE REMOVED
ERL EXISTING RELOCATED (NEW LOCATION)
ETL EXISTING TO BE RELOCATED (OLD LOCATION)
EX EXISTING TO REMAIN
FACP FIRE ALARM CONTROL PANEL
GC GENERAL CONTRACTOR
GFI GROUND FAULT INTERRUPTER
HV HEATING AND VENTILATION CONTRACTOR
IG ISOLATED GROUND
IR IN ROOM
IU IN UNIT
MAN MANUAL STARTER
MAG MAGNETIC STARTER
MCA MINIMUM CIRCUIT AMPACITY
NIC NOT IN CONTRACT
NL NIGHT LIGHT
NU NEAR UNIT
PB PUSH-BUTTON
PC PLUMBING CONTRACTOR
FW FIRE-WIRED
RV REDUCED VOLTAGE STARTER
RAI REMAIN AS IS
SC SEPARATE CIRCUIT
SS SPEED SWITCH
SW SWITCH
TC TIMECLOCK
TS THERMOSTAT
UM UNIT MANUFACTURER
WP WEATHERPROOF

LIGHT FIXTURE SCHEDULE

Table with columns: TAG, NO, LAMP DATA, DESCRIPTION, MAKE, LIGHTING FIXTURE, CATALOG NO, MOUNT, CEILING TYPE, VOLT, SEE NOTE. Includes items A through X and EBU-C.

- NOTES:
1. SEE PLANS FOR LENGTHS.
2. COLOR PER ARCHITECT.
3. PROVIDE (A) SECTIONS OF ANLU C/WOL (2) ANLU CLUT 1/2" TAPE LIGHT (1) ANLU CLUT BRK (1) ANLU CLUT 1/2" POWER SUPPLY

SPECIAL OUTLET SCHEDULE

Table with columns: TAG, DRIVING, LOC, FEED FROM, BREAKER, BRANCH WIRING, POWER, SEE NOTE. Includes items HD-1 through WH-1.

- NOTES:
1. PROVIDE NEMA 5-15R RECEPTACLE MOUNT AT 48" AFF TO CENTER OF BOX. PROVIDE DEAD FRONT GFI DEVICE IN A READILY ACCESSIBLE LOCATION.
2. PROVIDE NEMA TYPE 5-20R RECEPTACLE. MOUNT RECEPTACLE ACCORDING TO MANUFACTURE'S REQUIREMENTS.
3. PROVIDE A DEAD FRONT GFI DEVICE AND INSTALL IN NEAR THE ELECTRIC WATER COOLER IN AN ACCESSIBLE LOCATION.
4. PROVIDE NEMA 5-15R RECEPTACLE MOUNT INSIDE THE CABINARTY. PROVIDE DEAD FRONT GFI DEVICE IN A READILY ACCESSIBLE LOCATION.
5. VERIFY MOUNTING HEIGHT WITH EQUIPMENT PROVIDER PRIOR TO INSTALLATION.
6. PROVIDE NEMA 5-15R RECEPTACLE.
7. PROVIDE NEMA 5-15R RECEPTACLE. MOUNT ABOVE COUNTER. VERIFY MOUNTING HEIGHT WITH OWNER PRIOR TO ROUGH-IN.
8. FURNISHED BY SECTION 09 30 00.
9. WIRE TIMECLOCK FURNISHED BY PLUMBER.

MOTOR WIRING SCHEDULE

Table with columns: TAG, DRIVING, LOC, POWER, FEED FROM, BREAKER, BRANCH WIRING, STARTER, DISCONNECT, SEE NOTE. Includes item PRV-4.

- ABBREVIATIONS:
2SP = 2 SPEED MAGNETIC STARTER
BOL = BUILT-IN OVERLOAD
CS = COMBINATION STARTER
EC = ELECTRICAL CONTRACTOR
ECP = ELEVATOR CONTROL PANEL
EV = ELEVATOR CONTRACTOR
FD = FUSIBLE DISCONNECT
HV = HVAC CONTRACTOR
IU = IN UNIT
LMRS = LOCKABLE MOTOR RATED SWITCH
MAN = MANUAL STARTER
MAG = MAGNETIC STARTER
MC = MECHANICAL CONTRACTOR
MCC = MOTOR CONTROL CENTER
HOA = HAND-OFF-AUTO
MCA = MINIMUM CIRCUIT AMPS
MFR = MANUFACTURER
NFD = NON-FUSIBLE DISCONNECT
NU = NEAR UNIT
OU = ON UNIT
PC = PLUMBING CONTRACTOR
PL = PILOT LIGHT
RVS = REDUCED VOLTAGE STARTER
TCP = TEMPERATURE CONTROL PANEL
T-STAT = THERMOSTAT
VFD = VARIABLE FREQUENCY DRIVE
WP = WEATHERPROOF
STST = START/STOP

- NOTES:
1. xxxxx