

# 2016 RESTORATION CAPITOL SQUARE SOUTH PARKING RAMP DANE COUNTY, WI



113 S. HENRY STREET  
MADISON, WI 53703

DANE COUNTY RFB # 316005  
APRIL 12, 2016

## PROJECT LOCATION

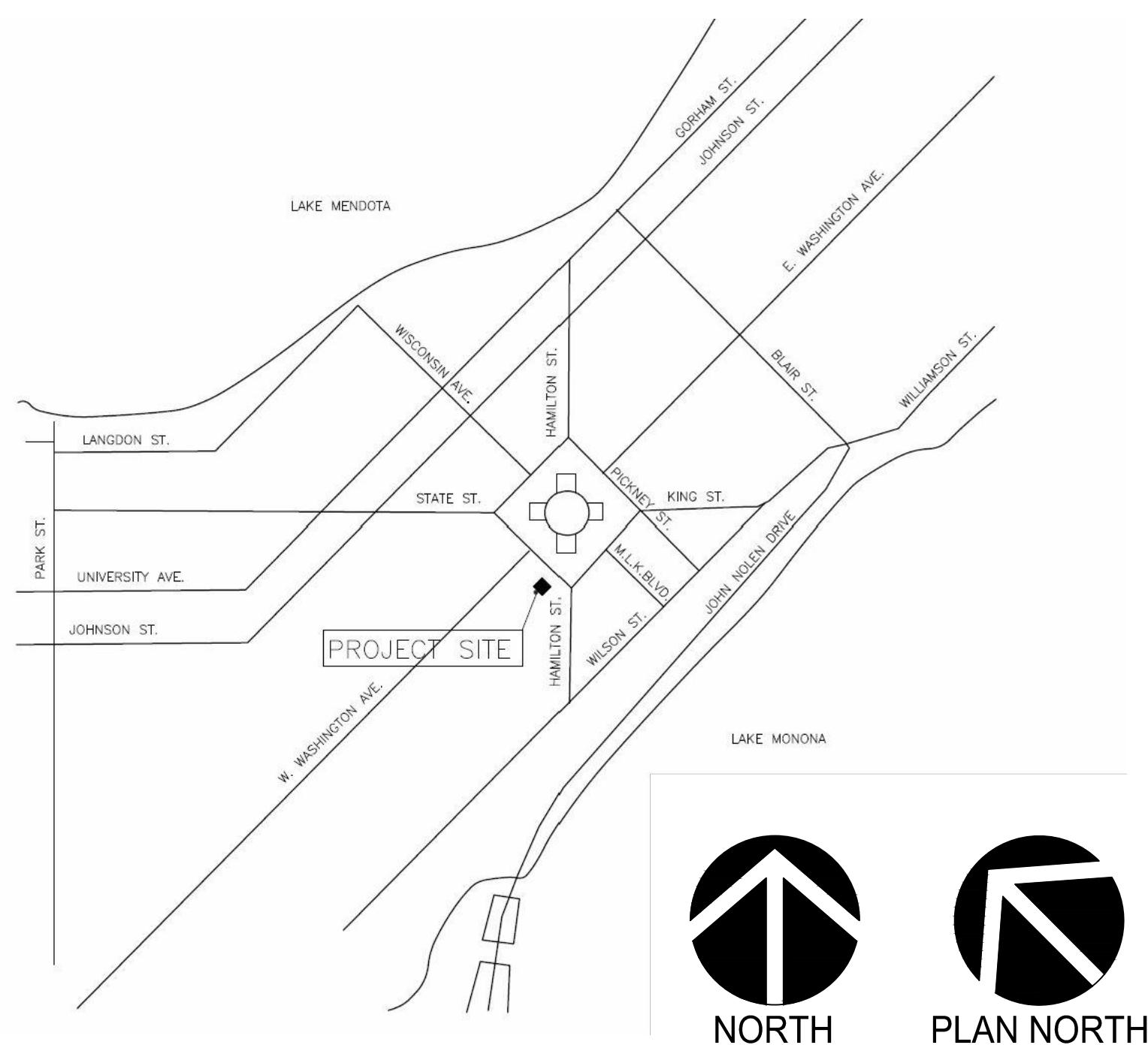

DRAWING INDEX	
T-1	TITLE SHEET
S-1	LEVEL 2 UNDERSIDE PLAN
S-2	LEVEL 3 UNDERSIDE PLAN
S-3	LEVEL 4 UNDERSIDE PLAN
S-4	LEVEL 5 UNDERSIDE PLAN
S-5	LEVEL 6 UNDERSIDE PLAN
S-6	LEVEL 7 UNDERSIDE PLAN
S-7	LEVEL 7 TOPSIDE PLAN AND DETAILS

INFORMATION PERTAINING TO EXISTING CONDITIONS GIVEN ON THESE DRAWINGS REPRESENTS TO THE BEST OF OUR KNOWLEDGE THE ACTUAL EXISTING FIELD CONDITIONS. JSD PROFESSIONAL SERVICES, INC. MAKES NO WARRANTY AS TO THEIR ACCURACY. CONTRACTOR TO FIELD VERIFY EXISTING CONDITIONS IMPERATIVE TO THE NEW WORK. REPORT DISCREPANCIES BETWEEN DRAWINGS AND FIELD CONDITIONS TO THE ENGINEER FOR REVIEW. ANY WORK PERFORMED PRIOR TO RESOLUTION OF DISCREPANCIES BY THE ENGINEER IS SUBJECT TO REMOVAL AND REPLACEMENT AT NO ADDITIONAL COST TO THE CONTRACT. CONTRACTORS ARE RESPONSIBLE FOR THE MEANS, METHODS, TECHNIQUES, SEQUENCES, AND PROCEDURES OF CONSTRUCTION INCLUDING, BUT NOT LIMITED TO TEMPORARY SUPPORTS, SHORING, AND FORMING TO SUPPORT IMPOSED LOADS AND OTHER SIMILAR ITEMS. THE LOCATION OF DETERIORATED CONCRETE AND CRACKS SHOWN ARE FOR REFERENCE PURPOSES ONLY. DETERIORATED CONCRETE AREAS AND CRACKS TO BE REPAIRED WILL BE VERIFIED BY THE ENGINEER AT THE TIME OF CONSTRUCTION.

**JSD Professional Services, Inc.**  
• Engineers • Surveyors • Planners

"BUILDING RELATIONSHIPS WITH A COMMITMENT TO CLIENT SATISFACTION THROUGH TRUST, QUALITY AND EXPERIENCE"

- CIVIL ENGINEERING
- SURVEYING & MAPPING
- CONSTRUCTION SERVICES
- WATER RESOURCES
- PLANNING & DEVELOPMENT
- TRANSPORTATION ENGINEERING
- STRUCTURAL ENGINEERING
- LANDSCAPE ARCHITECTURE

MADISON REGIONAL OFFICE  
161 HORIZON DRIVE, SUITE 101  
VERONA, WISCONSIN 53593  
608.848.5060 PHONE | 608.848.2255 FAX

MADISON | MILWAUKEE  
KENOSHA | APPLETON  
[www.jsdinc.com](http://www.jsdinc.com)

SERVICES PROVIDED TO:

DANE  
COUNTY  
PUBLIC  
WORKS



1919 ALLIANT ENERGY CENT. WAY  
MADISON, WI 53713

PROJECT:

2016 RESTORATION  
CAPITOL SQUARE  
SOUTH  
PARKING RAMP

PROJECT LOCATION:

113 S. HENRY STREET  
MADISON, WI 53703

RFB #: 316005

SEAL/SIGNATURE:

ALTHOUGH EVERY EFFORT HAS BEEN MADE IN PREPARING THESE PLANS AND CHECKING THEM FOR ACCURACY, THE CONTRACTOR AND SUBCONTRACTORS MUST CHECK ALL DETAIL AND DIMENSIONS OF THEIR TRADE AND BE RESPONSIBLE FOR THE SAME.

DESIGN: PGB 03/29/2016  
DRAWN: PGB  
APPROVED: JJE

PLAN MODIFICATIONS: DATE:  
ISSUED FOR CONSTRUCTION 04/12/2016

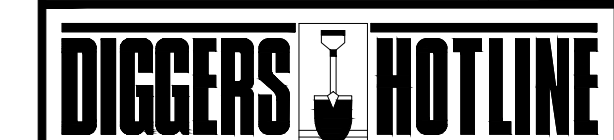

Toll Free (800) 242-8511  
Milwaukee Area (414) 259-1181  
Hearing Impaired TDD (800) 542-2289  
[www.DiggersHotline.com](http://www.DiggersHotline.com)

SHEET TITLE:

TITLE SHEET

SHEET NUMBER:

T-1

- CIVIL ENGINEERING
- SURVEYING & MAPPING
- CONSTRUCTION SERVICES
- WATER RESOURCES
- PLANNING & DEVELOPMENT
- TRANSPORTATION ENGINEERING
- STRUCTURAL ENGINEERING
- LANDSCAPE ARCHITECTURE

MADISON REGIONAL OFFICE  
 161 HORIZON DRIVE, SUITE 101  
 VERONA, WISCONSIN 53593  
 608.848.5060 PHONE | 608.848.2255 FAX

MADISON | MILWAUKEE  
 KENOSHA | APPLETON

www.jsdinc.com

SERVICES PROVIDED TO:

**DANE COUNTY PUBLIC WORKS**



1919 ALLIANT ENERGY CENT. WAY  
 MADISON, WI 53713

PROJECT:

**2016 RESTORATION  
 CAPITOL SQUARE  
 SOUTH  
 PARKING RAMP**

PROJECT LOCATION:

113 S. HENRY STREET  
 MADISON, WI 53703

RFB #: 316005

SEAL/SIGNATURE:

ALTHOUGH EVERY EFFORT HAS BEEN MADE IN PREPARING THESE PLANS AND CHECKING THEM FOR ACCURACY, THE CONTRACTOR AND SUBCONTRACTORS MUST CHECK ALL DETAIL AND DIMENSIONS OF THEIR TRADE AND BE RESPONSIBLE FOR THE SAME.

DESIGN: PGB 03/29/2016  
 DRAWN: PGB  
 APPROVED: JJE

PLAN MODIFICATIONS:	DATE:
ISSUED FOR CONSTRUCTION	04/12/2016



Toll Free (800) 242-8511  
 Milwaukee Area (414) 259-1181  
 Hearing Impaired TDD (800) 542-2289  
 www.DiggersHotline.com

SHEET TITLE:

**LEVEL 2  
 UNDERSIDE  
 PLAN**

SHEET NUMBER:

**S-1**

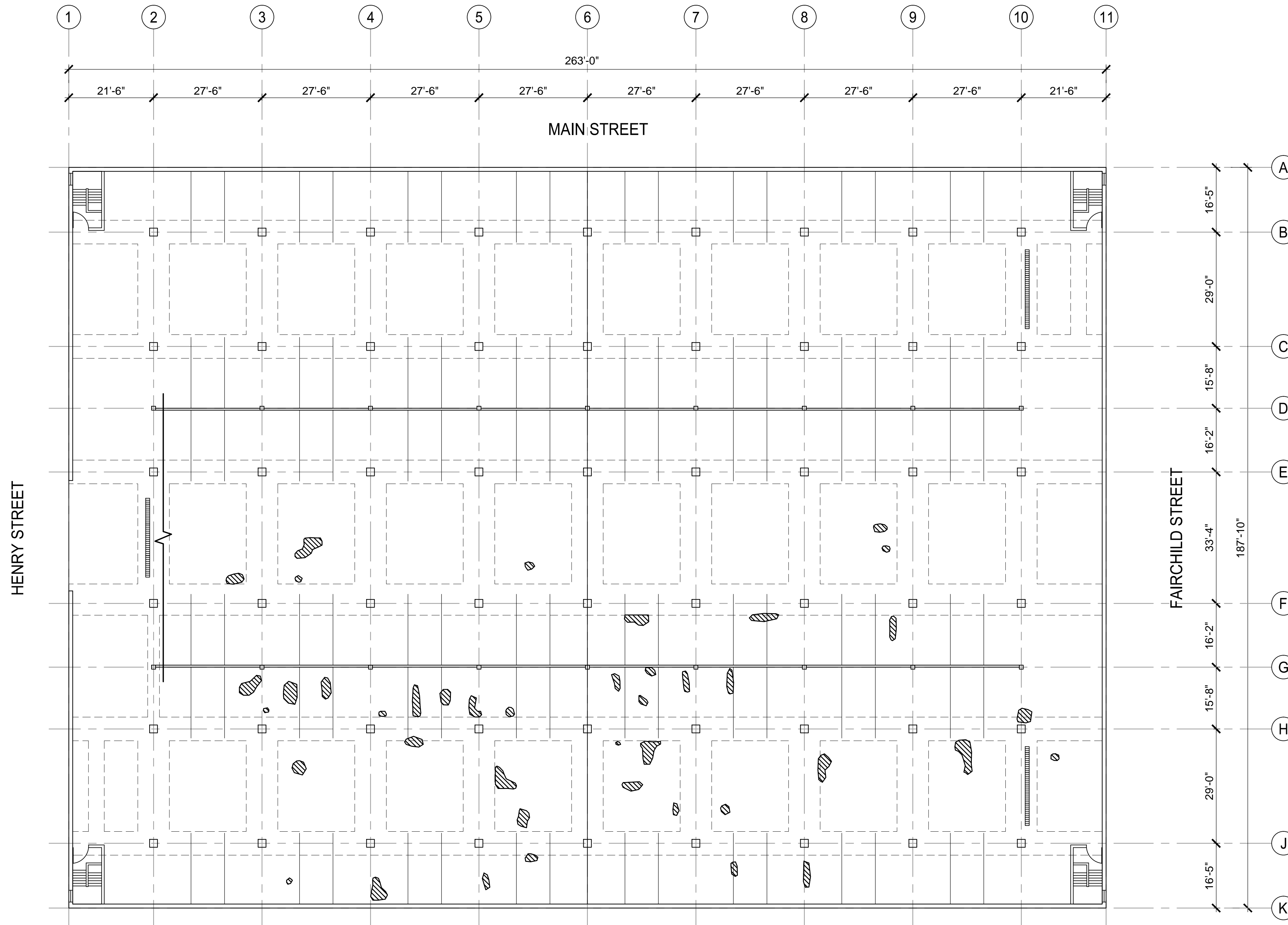

**1**  
**S-1**

**LEVEL 2 UNDERSIDE PLAN**

1/16" = 1'-0" @ 22"x34" SHEET  
 1/32" = 1'-0" @ 11"x17" SHEET



NORTH

**LEGEND**

UNDERSIDE CONCRETE DELAMINATION AREA, REFER TO SECTION 01 15 10 - UNIT PRICES

LEVEL 2 UNDERSIDE PLAN REFERS TO STANDING ON LEVEL 1 AND LOOKING UP TO THE UNDERSIDE OF LEVEL 2, PER FLOOR DESIGNATION SIGNS ON WALLS. STRIPES AND RAMPS SHOWN ON PLAN ARE IN REFERENCE TO LEVEL 1.

SERVICES PROVIDED TO:

**DANE COUNTY PUBLIC WORKS**



1919 ALLIANT ENERGY CENT. WAY  
 MADISON, WI 53713

PROJECT:

**2016 RESTORATION  
 CAPITOL SQUARE  
 SOUTH  
 PARKING RAMP**

PROJECT LOCATION:

113 S. HENRY STREET  
 MADISON, WI 53703

RFB #: 316005

SEAL/SIGNATURE:

ALTHOUGH EVERY EFFORT HAS BEEN MADE IN PREPARING THESE PLANS AND CHECKING THEM FOR ACCURACY, THE CONTRACTOR AND SUBCONTRACTORS MUST CHECK ALL DETAIL AND DIMENSIONS OF THEIR TRADE AND BE RESPONSIBLE FOR THE SAME.

DESIGN: PGB 03/29/2016  
 DRAWN: PGB  
 APPROVED: JJE

PLAN MODIFICATIONS:	DATE:
ISSUED FOR CONSTRUCTION	04/12/2016

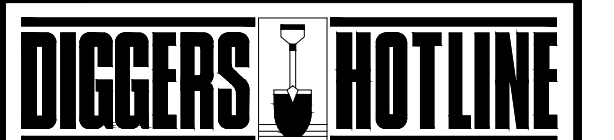

Toll Free (800) 242-8511  
 Milwaukee Area (414) 259-1181  
 Hearing Impaired TDD (800) 542-2289  
[www.DiggersHotline.com](http://www.DiggersHotline.com)

SHEET TITLE:

**LEVEL 3  
 UNDERSIDE  
 PLAN**

SHEET NUMBER:

**S-2**

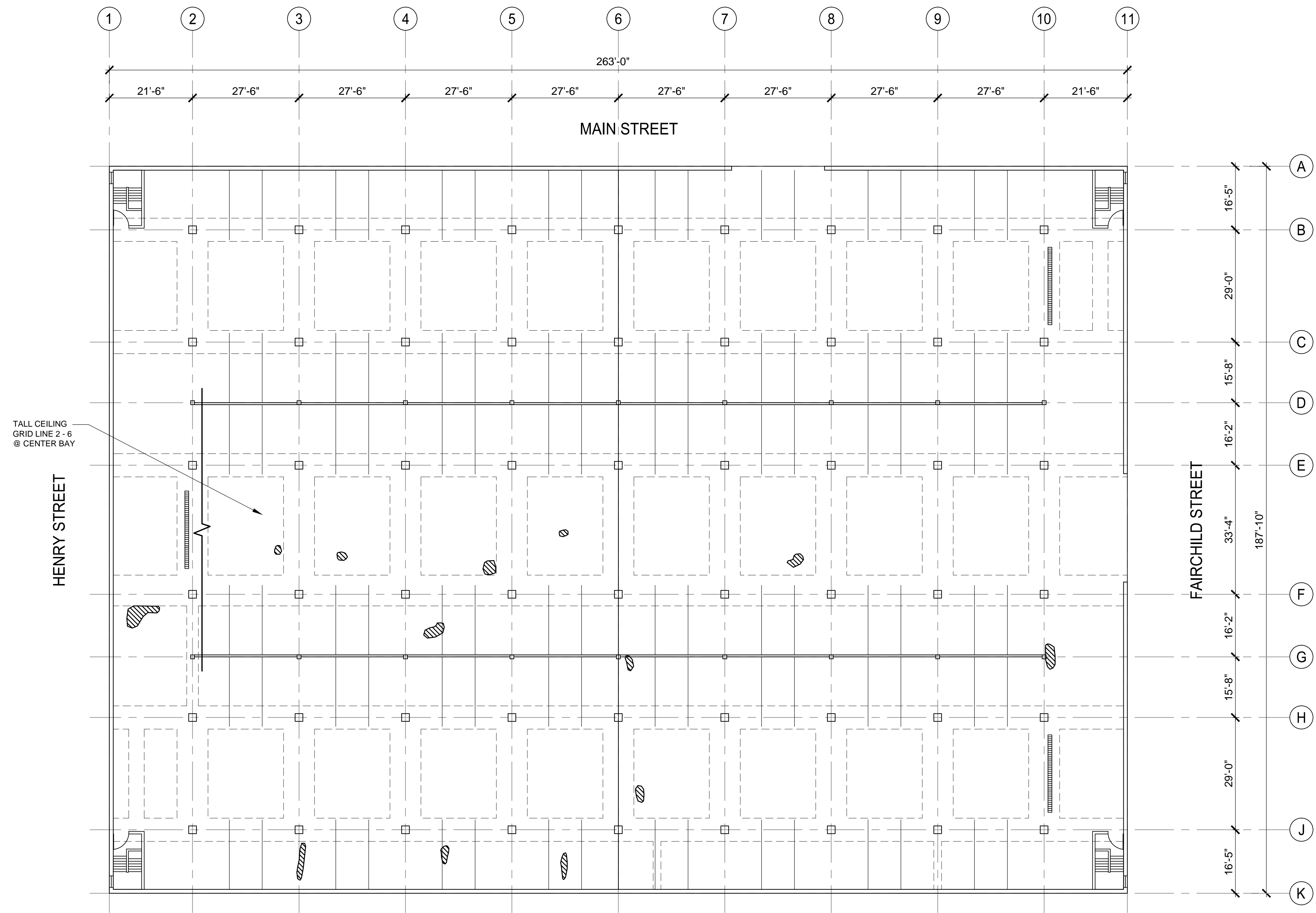

**1 LEVEL 3 UNDERSIDE PLAN**  
**S-2**  
 1/16" = 1'-0" @ 22"x34" SHEET  
 1/32" = 1'-0" @ 11"x17" SHEET



**LEGEND**  
 UNDERSIDE CONCRETE DELAMINATION AREA, REFER TO SECTION 01 15 10 - UNIT PRICES

LEVEL 3 UNDERSIDE PLAN REFERS TO STANDING ON LEVEL 2 AND LOOKING UP TO THE UNDERSIDE OF LEVEL 3, PER FLOOR DESIGNATION SIGNS ON WALLS. STRIPES AND RAMPS SHOWN ON PLAN ARE IN REFERENCE TO LEVEL 2.

SERVICES PROVIDED TO:

**DANE COUNTY PUBLIC WORKS**



1919 ALLIANT ENERGY CENT. WAY  
 MADISON, WI 53713

PROJECT:

**2016 RESTORATION  
 CAPITOL SQUARE  
 SOUTH  
 PARKING RAMP**

PROJECT LOCATION:

113 S. HENRY STREET  
 MADISON, WI 53703

RFB #: 316005

SEAL/SIGNATURE:

ALTHOUGH EVERY EFFORT HAS BEEN MADE IN PREPARING THESE PLANS AND CHECKING THEM FOR ACCURACY, THE CONTRACTOR AND SUBCONTRACTORS MUST CHECK ALL DETAIL AND DIMENSIONS OF THEIR TRADE AND BE RESPONSIBLE FOR THE SAME.

DESIGN: PGB 03/29/2016

DRAWN: PGB

APPROVED: JJE

PLAN MODIFICATIONS: DATE:

ISSUED FOR CONSTRUCTION 04/12/2016



Toll Free (800) 242-8511  
 Milwaukee Area (414) 259-1181  
 Hearing Impaired TDD (800) 542-2289  
[www.DiggersHotline.com](http://www.DiggersHotline.com)

SHEET TITLE:

**LEVEL 4  
 UNDERSIDE  
 PLAN**

SHEET NUMBER:

**S-3**

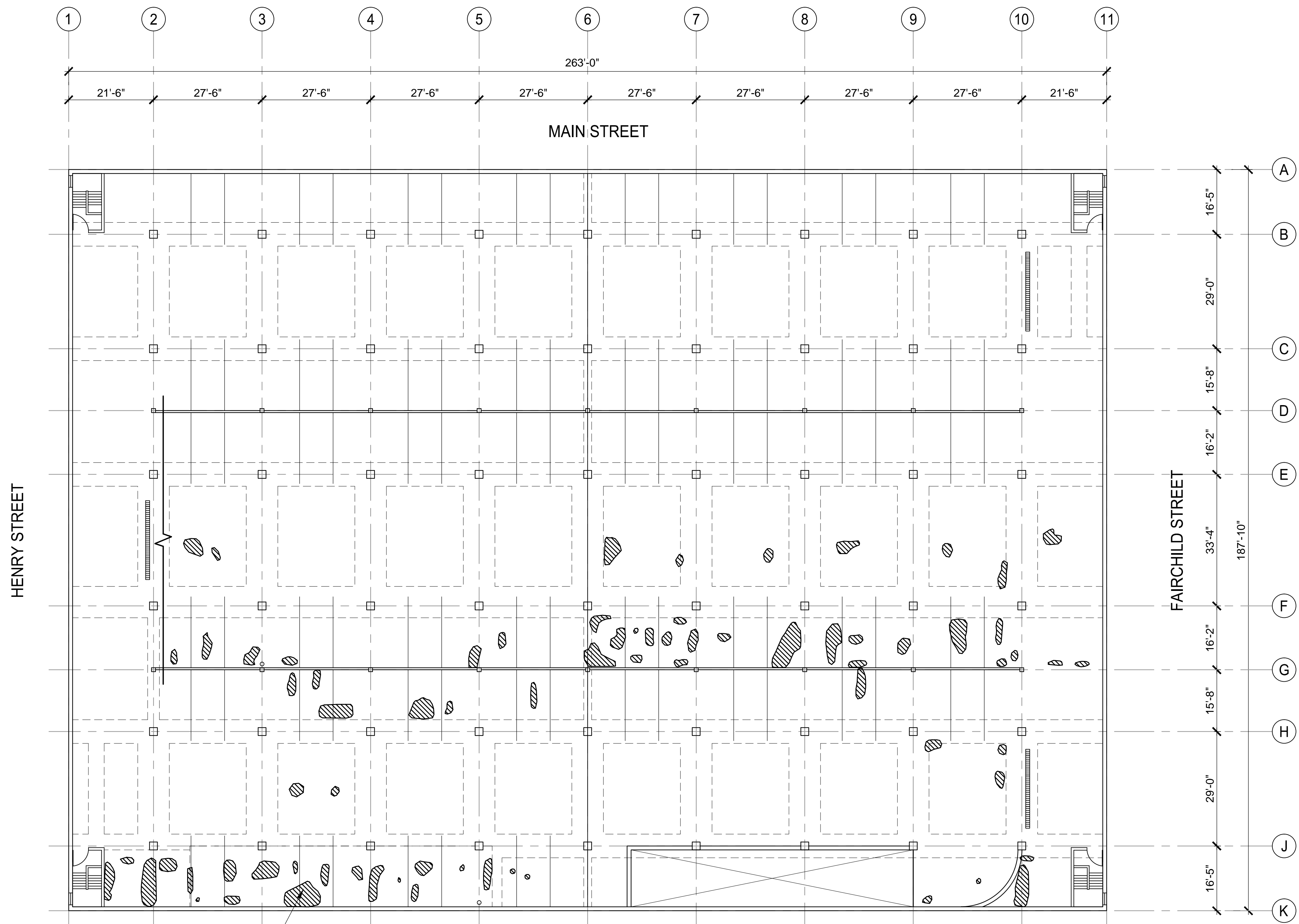

**1**  
**S-3**  
**LEVEL 4 UNDERSIDE PLAN**  
 1/16" = 1'-0" @ 22"x34" SHEET  
 1/32" = 1'-0" @ 11"x17" SHEET



**LEGEND**  
 UNDERSIDE CONCRETE DELAMINATION AREA, REFER TO SECTION 01 15 10 - UNIT PRICES

LEVEL 4 UNDERSIDE PLAN REFERS TO STANDING ON LEVEL 3 AND LOOKING UP TO THE UNDERSIDE OF LEVEL 4, PER FLOOR DESIGNATION SIGNS ON WALLS. STRIPES AND RAMPS SHOWN ON PLAN ARE IN REFERENCE TO LEVEL 3.

File: I:\2013\135982\2016 Restoration\DWG\2016 Restoration - GSS Ramp.dwg Layout: S-3 User: abaker PlotDate: Apr 11, 2016 - 1:30pm Xref's:

SERVICES PROVIDED TO:

**DANE COUNTY PUBLIC WORKS**



1919 ALLIANT ENERGY CENT. WAY  
 MADISON, WI 53713

PROJECT:

**2016 RESTORATION  
 CAPITOL SQUARE  
 SOUTH  
 PARKING RAMP**

PROJECT LOCATION:

113 S. HENRY STREET  
 MADISON, WI 53703

RFB #: 316005

SEAL/SIGNATURE:

ALTHOUGH EVERY EFFORT HAS BEEN MADE IN PREPARING THESE PLANS AND CHECKING THEM FOR ACCURACY, THE CONTRACTOR AND SUBCONTRACTORS MUST CHECK ALL DETAIL AND DIMENSIONS OF THEIR TRADE AND BE RESPONSIBLE FOR THE SAME.

DESIGN: PGB 03/29/2016

DRAWN: PGB

APPROVED: JJE

PLAN MODIFICATIONS: DATE:

ISSUED FOR CONSTRUCTION 04/12/2016



Toll Free (800) 242-8511  
 Milwaukee Area (414) 259-1181  
 Hearing Impaired TDD (800) 542-2289  
 www.DiggersHotline.com

SHEET TITLE:

**LEVEL 5  
 UNDERSIDE  
 PLAN**

SHEET NUMBER:

**S-4**

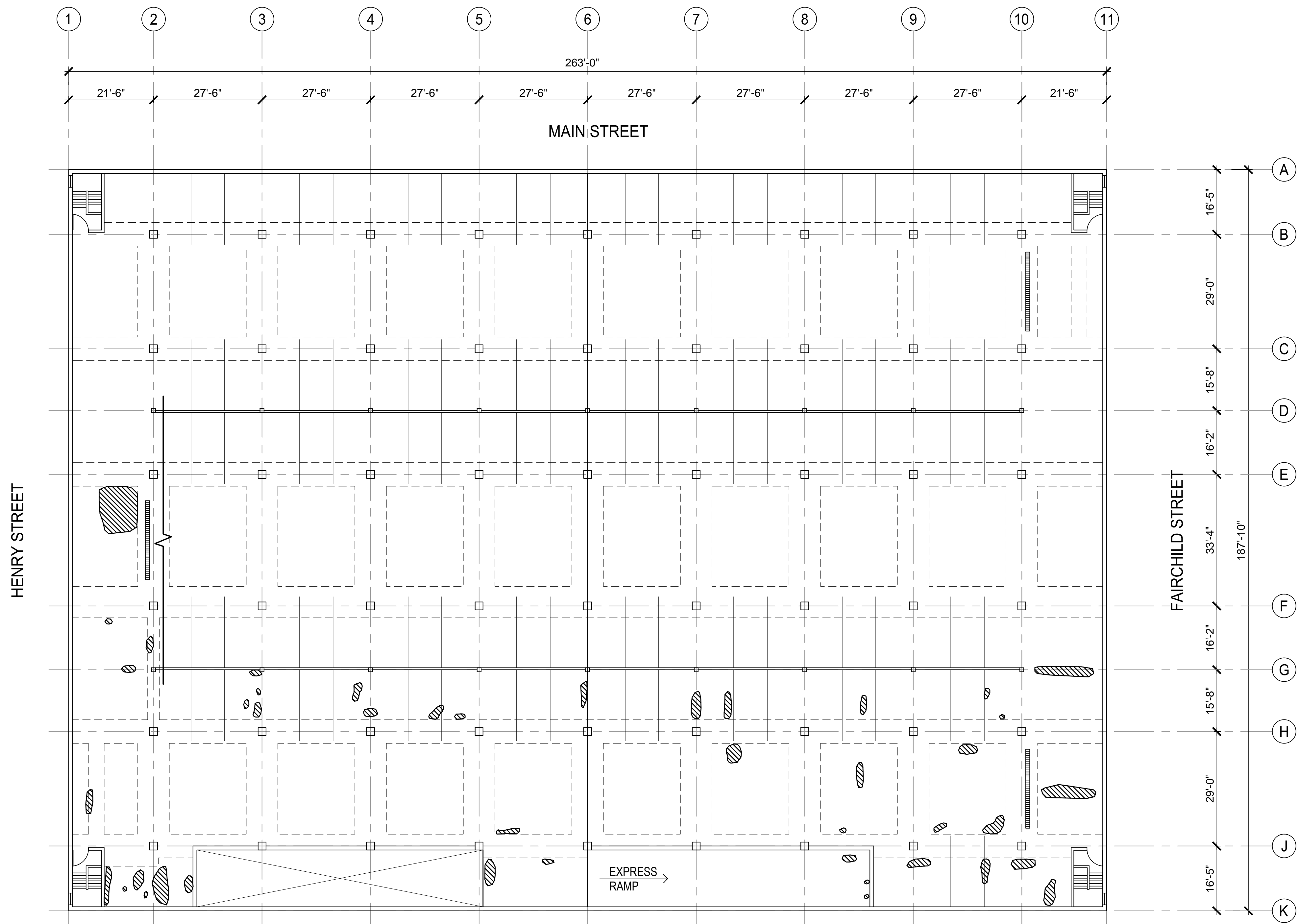

**1**  
**S-4**  
**LEVEL 5 UNDERSIDE PLAN**  
 1/16" = 1'-0" @ 22"x34" SHEET  
 1/32" = 1'-0" @ 11"x17" SHEET



**LEGEND**

UNDERSIDE CONCRETE DELAMINATION AREA, REFER TO SECTION 01 15 10 - UNIT PRICES

LEVEL 5 UNDERSIDE PLAN REFERS TO STANDING ON LEVEL 4 AND LOOKING UP TO THE UNDERSIDE OF LEVEL 5. PER FLOOR DESIGNATION SIGNS ON WALLS. STRIPES AND RAMPS SHOWN ON PLAN ARE IN REFERENCE TO LEVEL 4.

File: I:\2013\135982\2016 Restoration\DWG\2016 Restoration - GSS Ramp.dwg Layout: S-4 User: pbaker PlotDate: Apr 11, 2016 - 1:36pm Xref's:

- CIVIL ENGINEERING
- SURVEYING & MAPPING
- CONSTRUCTION SERVICES
- WATER RESOURCES
- PLANNING & DEVELOPMENT
- TRANSPORTATION ENGINEERING
- STRUCTURAL ENGINEERING
- LANDSCAPE ARCHITECTURE

MADISON REGIONAL OFFICE  
 161 HORIZON DRIVE, SUITE 101  
 VERONA, WISCONSIN 53593  
 608.848.5060 PHONE | 608.848.2255 FAX

MADISON | MILWAUKEE  
 KENOSHA | APPLETON

www.jsdinc.com

SERVICES PROVIDED TO:

**DANE COUNTY PUBLIC WORKS**



1919 ALLIANT ENERGY CENT. WAY  
 MADISON, WI 53713

PROJECT:

**2016 RESTORATION  
 CAPITOL SQUARE  
 SOUTH  
 PARKING RAMP**

PROJECT LOCATION:

113 S. HENRY STREET  
 MADISON, WI 53703

RFB #: 316005

SEAL/SIGNATURE:

ALTHOUGH EVERY EFFORT HAS BEEN MADE IN PREPARING THESE PLANS AND CHECKING THEM FOR ACCURACY, THE CONTRACTOR AND SUBCONTRACTORS MUST CHECK ALL DETAIL AND DIMENSIONS OF THEIR TRADE AND BE RESPONSIBLE FOR THE SAME.

DESIGN: PGB 03/29/2016  
 DRAWN: PGB  
 APPROVED: JJE

PLAN MODIFICATIONS:	DATE:
ISSUED FOR CONSTRUCTION	04/12/2016

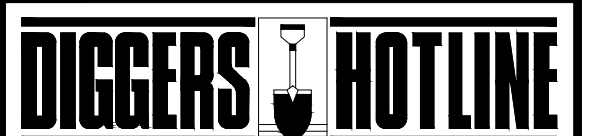

Toll Free (800) 242-8511  
 Milwaukee Area (414) 259-1181  
 Hearing Impaired TDD (800) 542-2289  
 www.DiggersHotline.com

SHEET TITLE:

**LEVEL 6  
 UNDERSIDE  
 PLAN**

SHEET NUMBER:

**S-5**

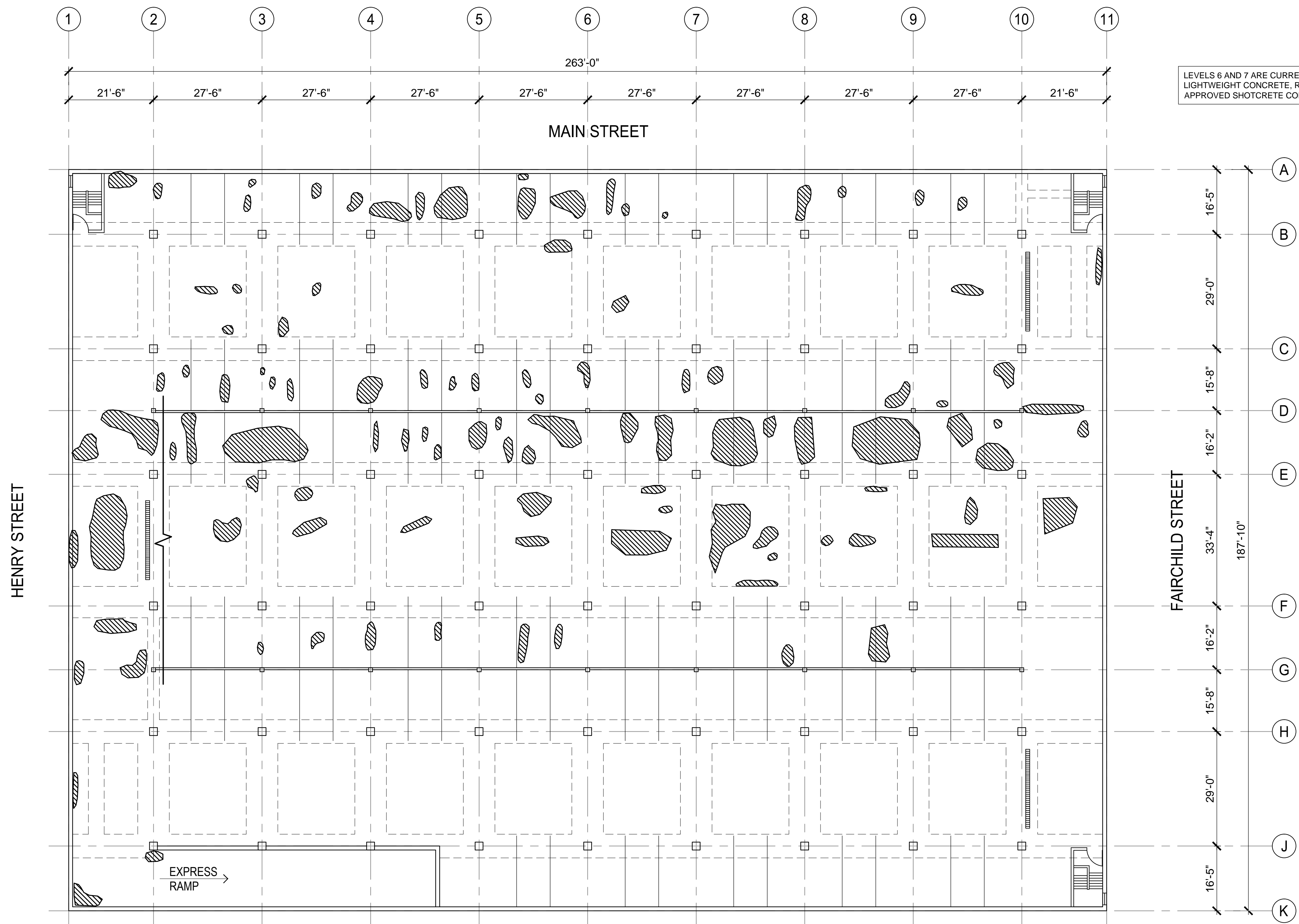

**1**  
**S-5**  
**LEVEL 6 UNDERSIDE PLAN**  
 1/16" = 1'-0" @ 22"x34" SHEET  
 1/32" = 1'-0" @ 11"x17" SHEET



**LEGEND**  
 UNDERSIDE CONCRETE DELAMINATION AREA, REFER TO SECTION 01 15 10 - UNIT PRICES

LEVEL 6 UNDERSIDE PLAN REFERS TO STANDING ON LEVEL 5 AND LOOKING UP TO THE UNDERSIDE OF LEVEL 6. PER FLOOR DESIGNATION SIGNS ON WALLS. STRIPES AND RAMPS SHOWN ON PLAN ARE IN REFERENCE TO LEVEL 5.

File: I:\2013\135982\2016 Restoration\DWG\2016 Restoration - GSS Ramp.dwg Layout: S-5 User: abaker PlotDate: Apr 11, 2016 - 1:39pm Xref's:

- CIVIL ENGINEERING
- SURVEYING & MAPPING
- CONSTRUCTION SERVICES
- WATER RESOURCES
- PLANNING & DEVELOPMENT
- TRANSPORTATION ENGINEERING
- STRUCTURAL ENGINEERING
- LANDSCAPE ARCHITECTURE

MADISON REGIONAL OFFICE  
 161 HORIZON DRIVE, SUITE 101  
 VERONA, WISCONSIN 53593  
 608.848.5060 PHONE | 608.848.2255 FAX

MADISON | MILWAUKEE  
 KENOSHA | APPLETON

www.jsdinc.com

SERVICES PROVIDED TO:

**DANE COUNTY PUBLIC WORKS**



1919 ALLIANT ENERGY CENT. WAY  
 MADISON, WI 53713

PROJECT:

**2016 RESTORATION  
 CAPITOL SQUARE  
 SOUTH  
 PARKING RAMP**

PROJECT LOCATION:

113 S. HENRY STREET  
 MADISON, WI 53703

RFB #: 316005

SEAL/SIGNATURE:

ALTHOUGH EVERY EFFORT HAS BEEN MADE IN PREPARING THESE PLANS AND CHECKING THEM FOR ACCURACY, THE CONTRACTOR AND SUBCONTRACTORS MUST CHECK ALL DETAIL AND DIMENSIONS OF THEIR TRADE AND BE RESPONSIBLE FOR THE SAME.

DESIGN: PGB 03/29/2016  
 DRAWN: PGB  
 APPROVED: JJE

PLAN MODIFICATIONS:	DATE:
ISSUED FOR CONSTRUCTION	04/12/2016

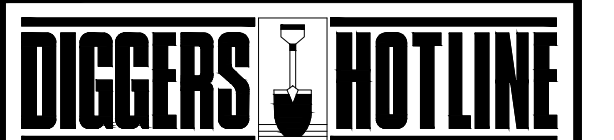

Toll Free (800) 242-8511  
 Milwaukee Area (414) 259-1181  
 Hearing Impaired TDD (800) 542-2289  
 www.DiggersHotline.com

SHEET TITLE:

**LEVEL 7  
 UNDERSIDE  
 PLAN**

SHEET NUMBER:

**S-6**

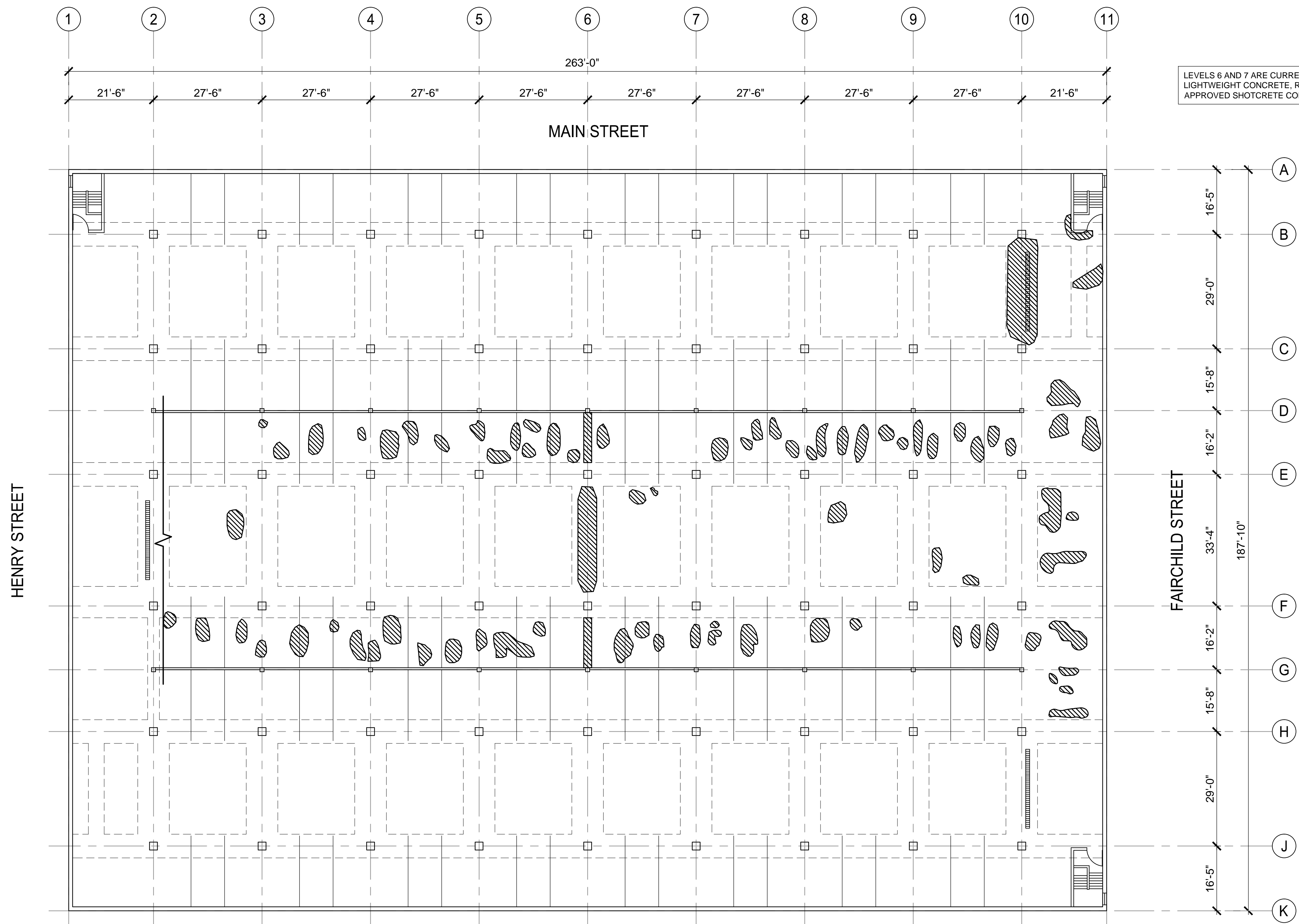

LEVELS 6 AND 7 ARE CURRENTLY LIGHTWEIGHT CONCRETE, REPLACE WITH APPROVED SHOTCRETE CONCRETE MIX.

**1 LEVEL 7 UNDERSIDE PLAN**  
**S-6**  
 1/16" = 1'-0" @ 22"x34" SHEET  
 1/32" = 1'-0" @ 11"x17" SHEET



**LEGEND**  
 UNDERSIDE CONCRETE DELAMINATION AREA, REFER TO SECTION 01 15 10 - UNIT PRICES

LEVEL 7 UNDERSIDE PLAN REFERS TO STANDING ON LEVEL 6 AND LOOKING UP TO THE UNDERSIDE OF LEVEL 7, PER FLOOR DESIGNATION SIGNS ON WALLS. STRIPES AND RAMPS SHOWN ON PLAN ARE IN REFERENCE TO LEVEL 6.

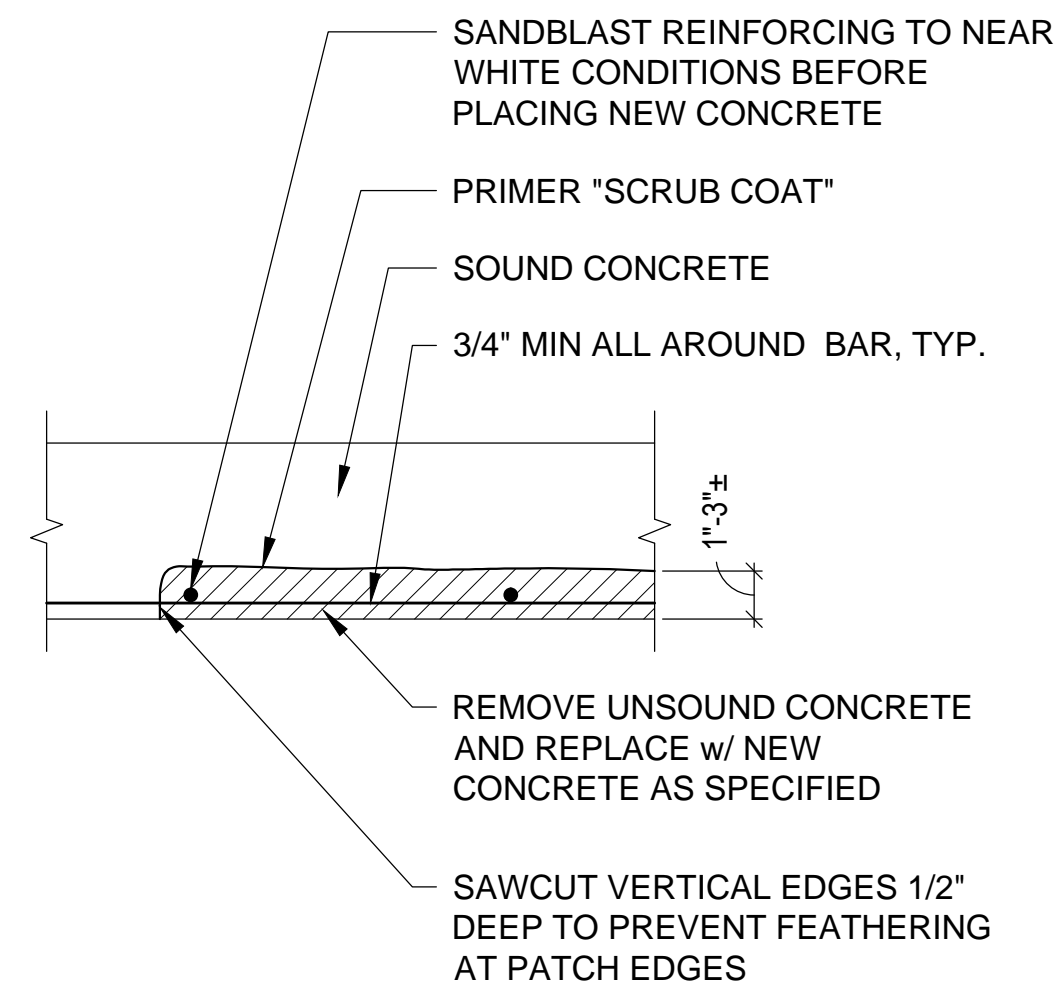

1 **UNDERSIDE SLAB RESTORATION**  
S-7 1" = 1'-0"

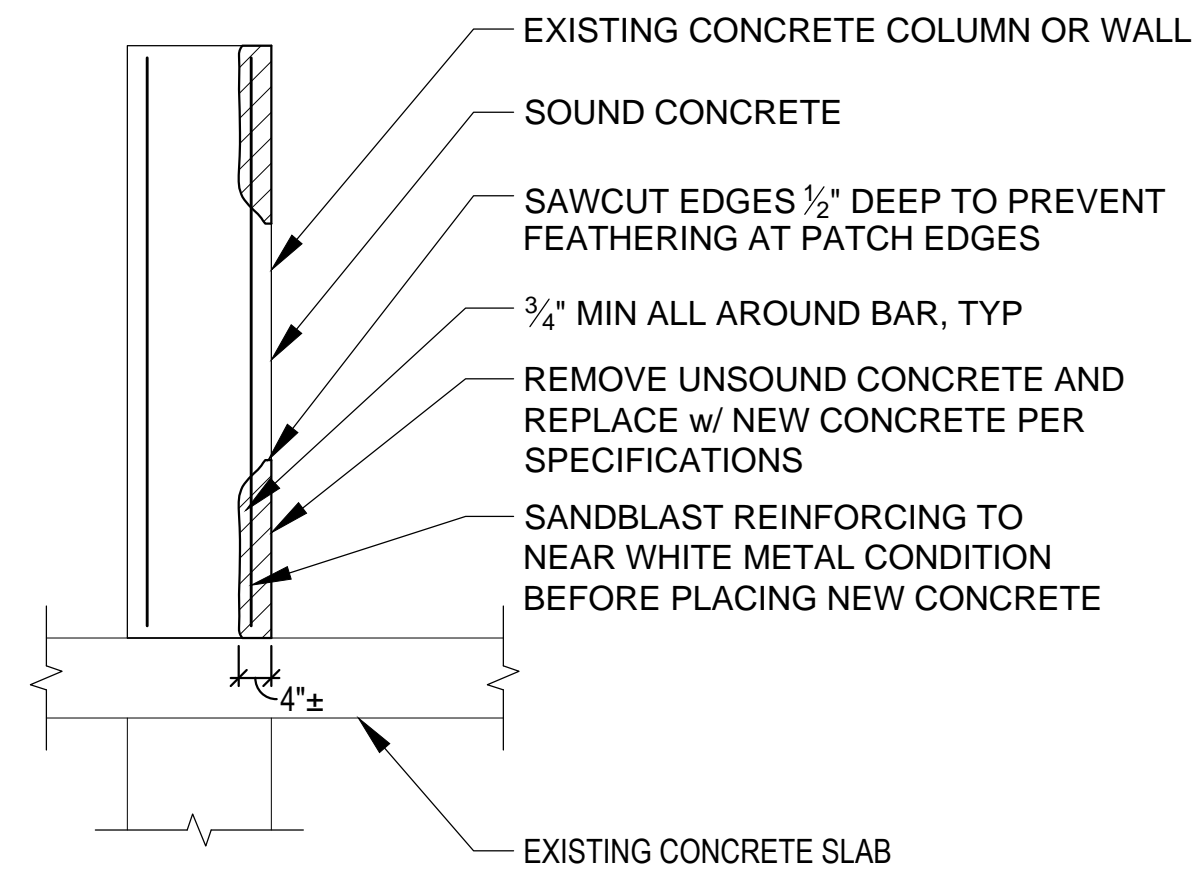

2 **CONCRETE REPAIR AT VERTICAL SURFACES**  
S-7 1" = 1'-0"

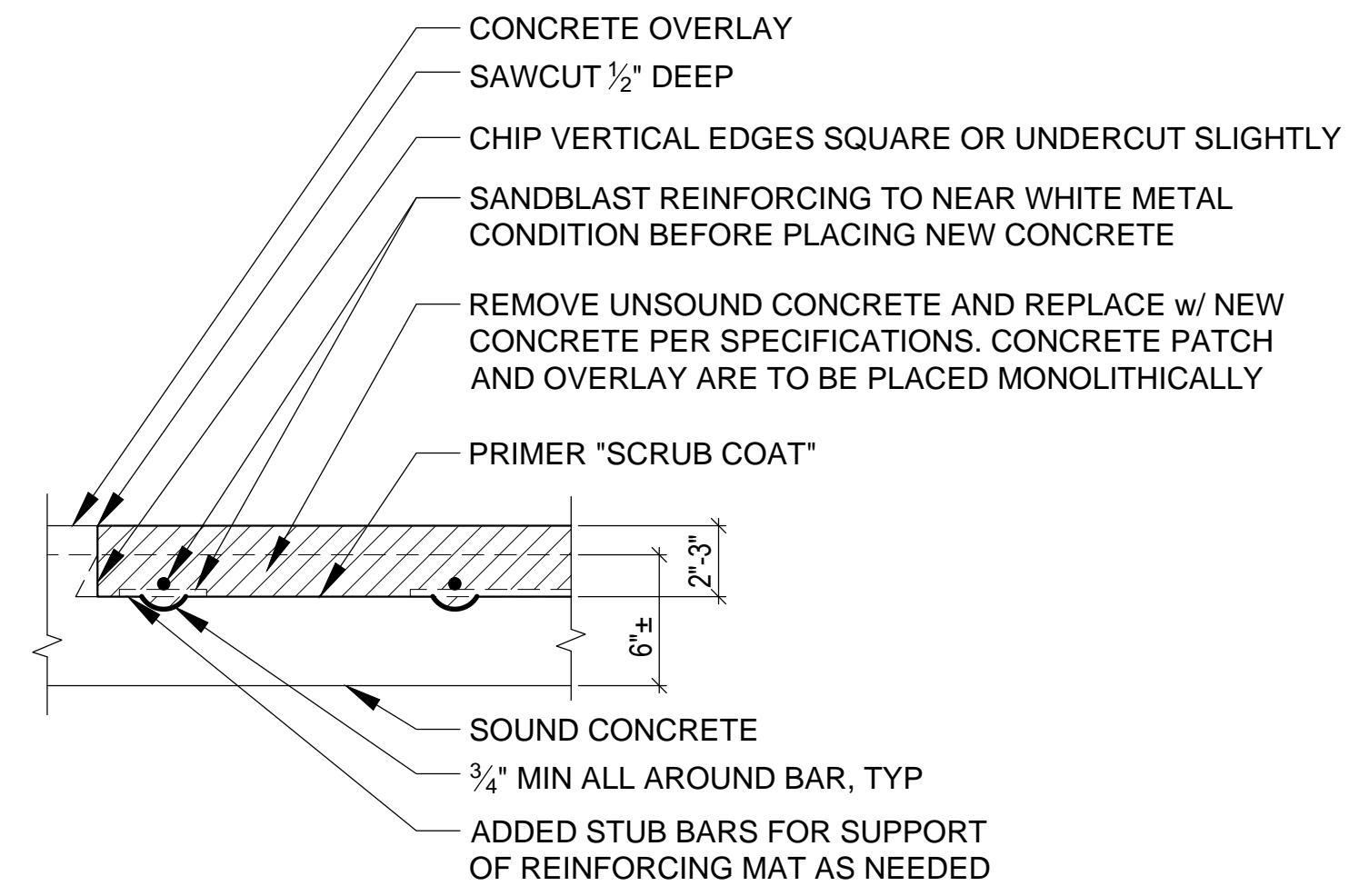

NOTE: REMOVAL OF CONCRETE BELOW SUPPORT BARS IS REQUIRED BY SPECIFICATION. NO ADDITIONAL PAYMENT FOR DEEPER REMOVAL IN THESE AREAS

3 **TOPSIDE SLAB RESTORATION - LEVEL 7**  
S-7 1" = 1'-0"

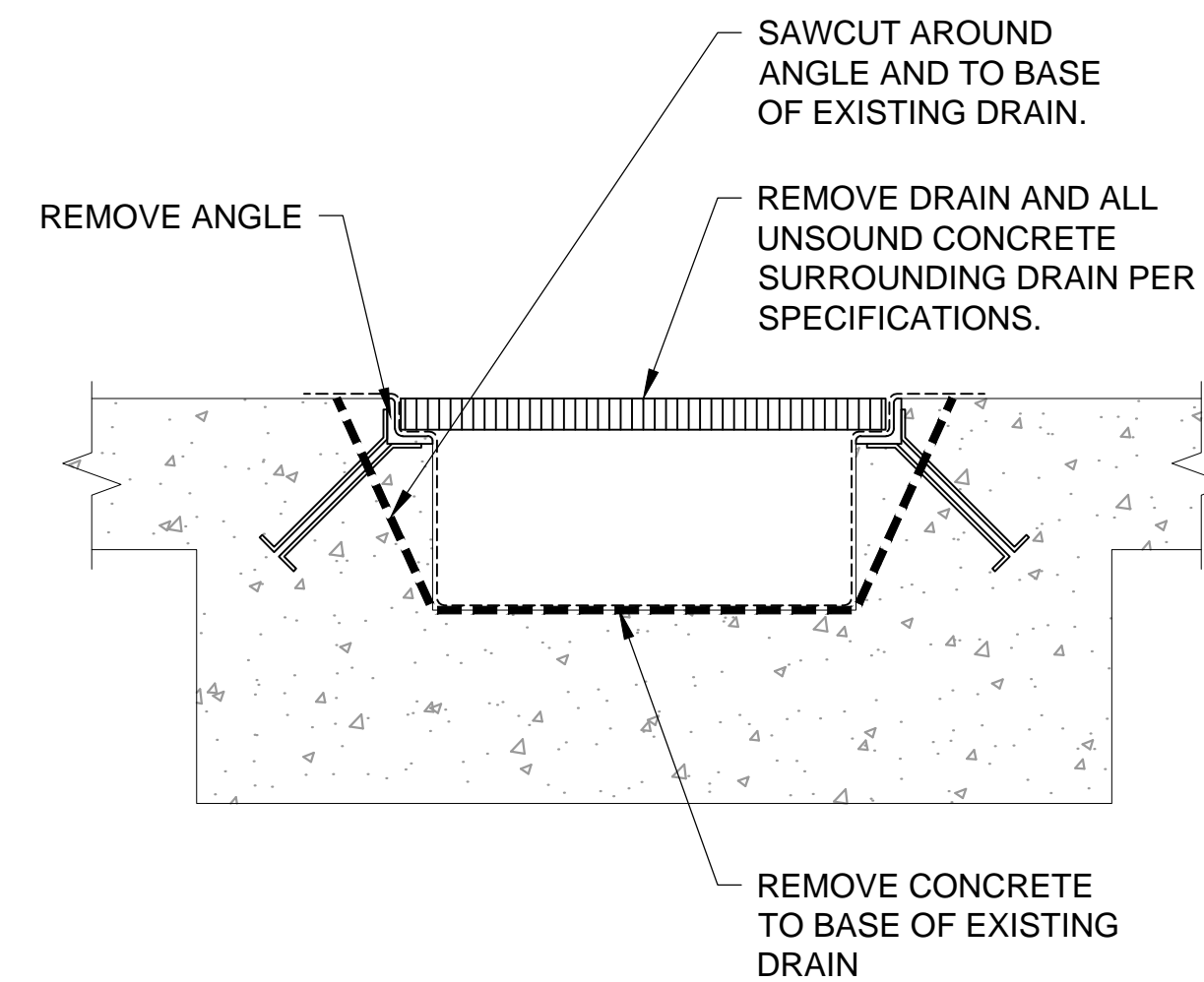

4 **TRENCH DRAIN REMOVAL**  
S-7 1" = 1'-0"

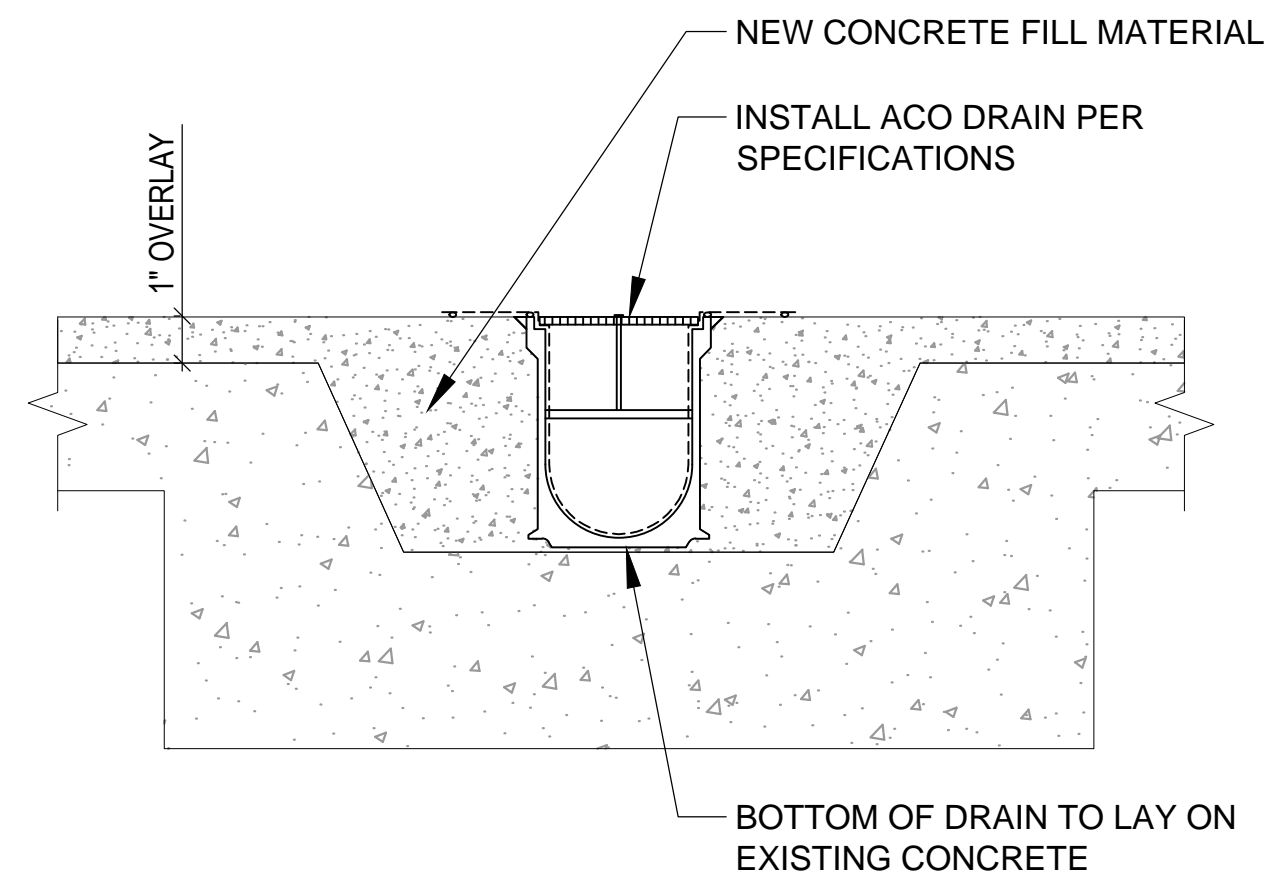

5 **TRENCH DRAIN INSTALLATION**  
S-7 1" = 1'-0"

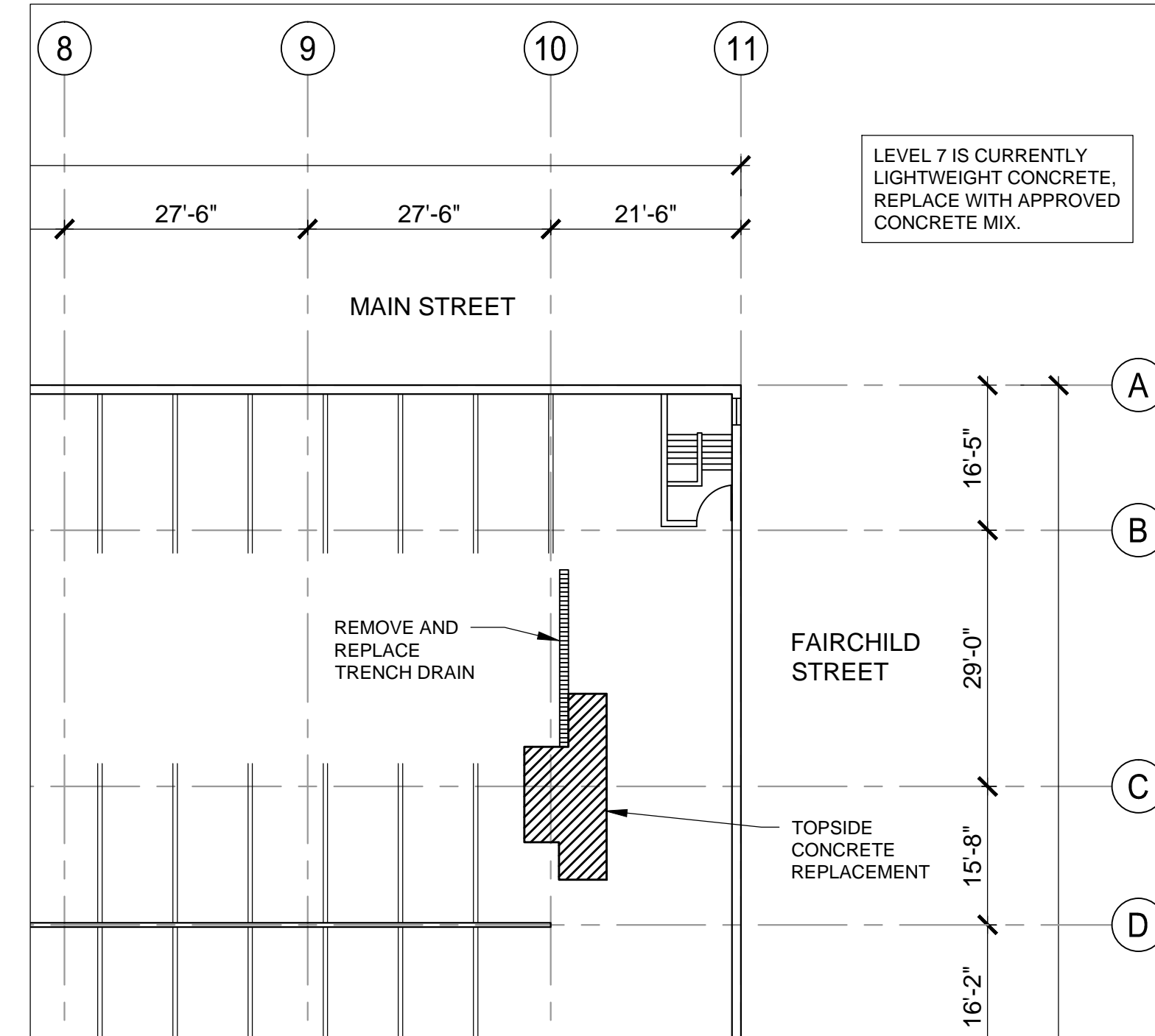

6 **LEVEL 7 TOPSIDE PLAN**  
S-7 1/16" = 1'-0" @ 22"x34" SHEET  
1/32" = 1'-0" @ 11"x17" SHEET

